

**TD10, TD52M and TD259**  
**Thermodynamic Steam Traps**  
Installation and Maintenance Instructions

---

---

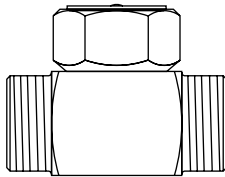

**TD10**

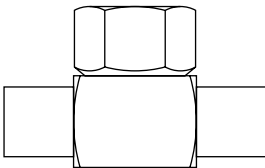

**TD52M**

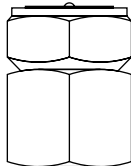

**TD259**

1. Safety information
2. General product information
3. Installation
4. Commissioning
5. Operation
6. Maintenance
7. Spare parts

---

# 1. Safety information

---

Safe operation of these products can only be guaranteed if they are properly installed, commissioned, used and maintained by qualified personnel (see Section 1.11) in compliance with the operating instructions. General installation and safety instructions for pipeline and plant construction, as well as the proper use of tools and safety equipment must also be complied with.

## 1.1 Intended use

Referring to the Installation and Maintenance Instructions, product markings and Technical Information Sheet, check that the product is suitable for the intended use/application. These products comply with the requirements of the European Pressure Equipment Directive 97/23/EC and all fall within category 'SEP'. It should be noted that products within this category are required by the Directive not to carry the CE mark.

- i) These products have been specifically designed for use on steam, air or condensate/water, which is in Group 2 of the above mentioned Pressure Equipment Directive. The products' use on other fluids may be possible but, if this is contemplated, Spirax Sarco should be contacted to confirm the suitability of the product for the application being considered.
- ii) Check material suitability, pressure and temperature and their maximum and minimum values. If the maximum operating limits of the product are lower than those of the system in which it is being fitted, or if malfunction of the product could result in a dangerous overpressure or overtemperature occurrence, ensure a safety device is included in the system to prevent such over-limit situations.
- iii) Determine the correct installation situation and direction of fluid flow.
- iv) Spirax Sarco products are not intended to withstand external stresses that may be induced by any system to which they are fitted. It is the responsibility of the installer to consider these stresses and take adequate precautions to minimise them.
- v) Remove protection covers from all connections and protective film from all name-plates, where appropriate, before installation on steam or other high temperature applications.

## 1.2 Access

Ensure safe access and if necessary a safe working platform (suitably guarded) before attempting to work on the product. Arrange suitable lifting gear if required.

## 1.3 Lighting

Ensure adequate lighting, particularly where detailed or intricate work is required.

## 1.4 Hazardous liquids or gases in the pipeline

Consider what is in the pipeline or what may have been in the pipeline at some previous time. Consider: flammable materials, substances hazardous to health, extremes of temperature.

## 1.5 Hazardous environment around the product

Consider: explosion risk areas, lack of oxygen (e.g. tanks, pits), dangerous gases, extremes of temperature, hot surfaces, fire hazard (e.g. during welding), excessive noise, moving machinery.

## 1.6 The system

Consider the effect on the complete system of the work proposed. Will any proposed action (e.g. closing isolation valves, electrical isolation) put any other part of the system or any personnel at risk?

Dangers might include isolation of vents or protective devices or the rendering ineffective of controls or alarms. Ensure isolation valves are opened and closed progressively to avoid system shocks.

---

## 1.7 Pressure systems

Ensure that any pressure is isolated and safely vented to atmospheric pressure. Consider double isolation (double block and bleed) and the locking or labelling of closed valves. Do not assume that the system has depressurised even when the pressure gauge indicates zero.

## 1.8 Temperature

Allow time for temperature to normalise after isolation to avoid the danger of burns.

## 1.9 Tools and consumables

Before starting work ensure that you have suitable tools and /or consumables available. Use only genuine Spirax Sarco replacement parts.

## 1.10 Protective clothing

Consider whether you and/or others in the vicinity require any protective clothing to protect against the hazards of, for example, chemicals, high /low temperature, radiation, noise, falling objects, and dangers to eyes and face.

## 1.11 Permits to work

All work must be carried out or be supervised by a suitably competent person. Installation and operating personnel should be trained in the correct use of the product according to the Installation and Maintenance Instructions.

Where a formal 'permit to work' system is in force it must be complied with. Where there is no such system, it is recommended that a responsible person should know what work is going on and, where necessary, arrange to have an assistant whose primary responsibility is safety.

Post 'warning notices' if necessary.

## 1.12 Handling

Manual handling of large and/or heavy products may present a risk of injury. Lifting, pushing, pulling, carrying or supporting a load by bodily force can cause injury particularly to the back. You are advised to assess the risks taking into account the task, the individual, the load and the working environment and use the appropriate handling method depending on the circumstances of the work being done.

## 1.13 Residual hazards

In normal use the external surface of the product may be very hot. If used at the maximum permitted operating conditions the surface temperature may reach temperatures in excess of 500°C (932°F).

Many products are not self-draining. Take due care when dismantling or removing the product from an installation (refer to 'Maintenance instructions').

## 1.14 Freezing

Provision must be made to protect products which are not self-draining against frost damage in environments where they may be exposed to temperatures below freezing point.

## 1.15 Disposal

Unless otherwise stated in the Installation and Maintenance Instructions, this product is recyclable and no ecological hazard is anticipated with its disposal providing due care is taken.

## 1.16 Returning products

Customers and stockists are reminded that under EC Health, Safety and Environment Law, when returning products to Spirax Sarco they must provide information on any hazards and the precautions to be taken due to contamination residues or mechanical damage which may present a health, safety or environmental risk. This information must be provided in writing including Health and Safety data sheets relating to any substances identified as hazardous or potentially hazardous.

# 2. General product information

## 2.1 General description

The **TD10** is a miniature thermodynamic disc trap designed specifically for draining small steam users like steam irons and instrument tracers.

The **TD52M** is a maintainable thermodynamic steam trap manufactured in stainless steel specifically designed for relatively small condensate loads, such as steam mains drainage. For very low condensate loads, a low capacity version is available. This is designated by the letters **LC** e.g. **TD52MLC**. For those applications where the release of air is a concern an anti-air-binding disc is available. This version is designated by the letter **A**, e.g. **TD52MA** and **TD52MLCA**.

The **TD259** is a maintainable thermodynamic steam trap for use on instrument tracing or any small bore steam heating installations. It can be provided with an anti-air-binding disc for quick start-up on batch process and is designated **TD259A**.

### Optional extras

An insulating cover (see Section 7, Spare parts) is available at extra cost for the 3/8", 1/2" and 3/4" TD52M range of thermodynamic steam traps (not available for the 1" size). An insulating cover will prevent the trap being unduly influenced by excessive heat loss such as when subjected to low outside temperatures, wind, rain etc.

### Standards

These products fully comply with the requirements of the European Pressure Equipment Directive 97/23/EC.

### Certification

<b>TD10</b>	This product is available with a manufacturer's Typical Test Report
<b>TD52M</b>	This product is available with certification to EN 10204 3.1
<b>TD259</b>	This product is available with a manufacturer's Typical Test Report

**Please note** that all certification / inspection requirements must be stated at the time of order placement.

**Note:** For additional product information see the following Technical Information sheets: **TD10** TI-P156-01, **TD52M** TI-P068-18 and **TD259** TI-P068-06.

## 2.2 Sizes and pipe connections

<b>TD10</b>	1/4" screwed Swaglock outlet/screwed BSP inlet
	1/4" screwed BSP taper male inlet/screwed BSP outlet
<b>TD52M</b>	1/4", 3/8", 1/2", 3/4" and 1" screwed BSP or NPT
<b>TD52MLC</b>	1/2" screwed BSP or NPT
<b>TD52MA</b>	3/8", 1/2", 3/4" and 1" screwed BSP or NPT
<b>TD52MLCA</b>	1/2" screwed BSP or NPT
<b>TD259</b>	1/4" screwed BSP or NPT

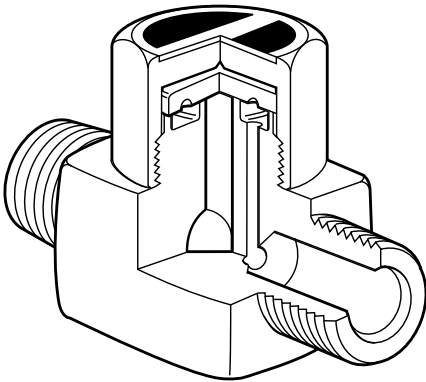
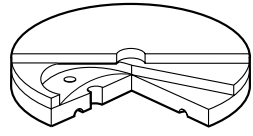

Fig. 1 TD10



Anti-air-binding disc

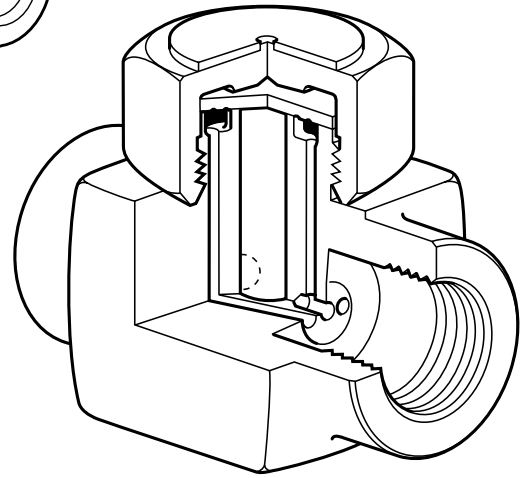

Fig. 2 TD52M

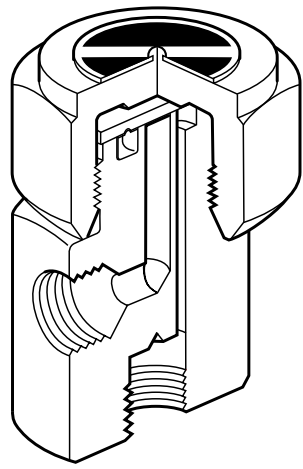
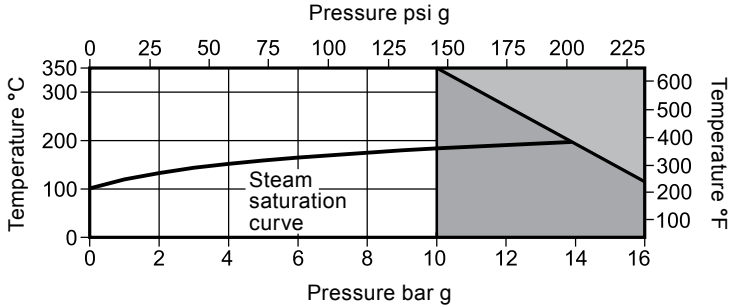

Fig. 3 TD259

### 2.3 TD10 Pressure / temperature limits (ISO 6552)



- The product **must not** be used in this region.
- For optimum product performance the PMO should not exceed 10 bar g (145 psi g).

Body design conditions		PN16	
PMA	Maximum allowable pressure	16 bar g @ 120°C	(232 psi g @ 248°F)
TMA	Maximum allowable temperature	350°C @ 10 bar g	(662°F @ 145 psi g)
	Minimum allowable temperature	0°C	(32°F)
PMO	Maximum operating pressure	10 bar g @ 350°C	(145 psi g @ 662°F)
TMO	Maximum operating temperature	350°C @ 10 bar g	(662°F @ 145 psi g)
	Minimum operating temperature	0°C	(32°F)
PMOB	Maximum operating backpressure must not exceed 50% of the upstream pressure.		
	Minimum operating differential pressure for satisfactory operation	0.25 bar	(3.6 psi)
	Designed for a maximum cold hydraulic test pressure of:	24 bar g	(348 psi g)

## 2.4 TD52M and TD52MA Pressure / temperature limits (ISO 6552)

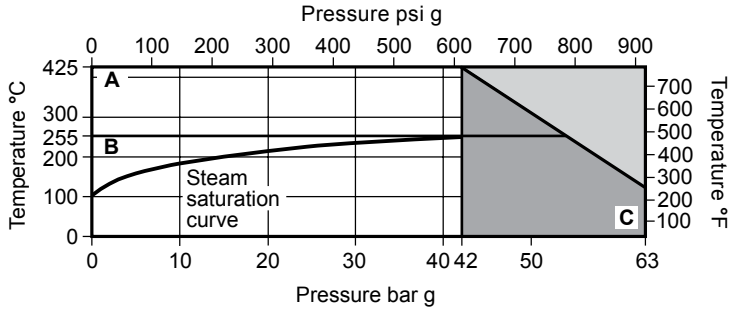

 The product **must not** be used in this region.

 For optimum product performance the PMO should not exceed 42 bar g (609 psi g).

**A - C TD52M and TD52MLC**

**B - C TD52MA and TD52MLCA**

Body design conditions			PN63
PMA	Maximum allowable pressure	63 bar g @ 120°C	(913 psi g @ 248°F)
TMA	Maximum allowable temperature	425°C @ 42 bar g	(797°F @ 609 psi g)
Minimum allowable temperature		0°C	(32°F)
PMO	Maximum operating pressure for saturated steam service	42 bar g @ 255°C	(609 psi g @ 491°F)
TMO	Maximum operating temperature	<b>TD52M</b> <b>TD52MLC</b>	425°C @ 42 bar g (797°F @ 609 psi g)
		<b>TD52MA</b> <b>TD52MLCA</b>	255°C @ 42 bar g (491°F @ 609 psi g)
Minimum operating temperature		0°C	(32°F)
PMOB	Maximum operating backpressure must not exceed 80% of the upstream pressure.		
Minimum operating differential pressure for satisfactory operation	<b>TD52M</b> <b>TD52MLC</b>	0.25 bar	(3.6 psi)
	<b>TD52MA</b> <b>TD52MLCA</b>	0.8 bar	(11.6 psi)
Designed for a maximum cold hydraulic test pressure of:		95 bar g	(1377 psi g)

## 2.5 TD259 and TD259A Pressure / temperature limits (ISO 6552)

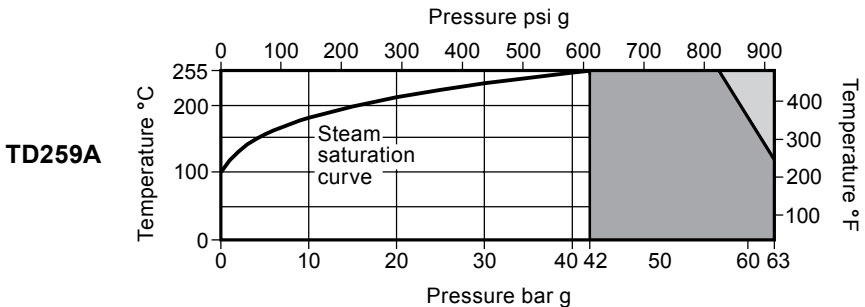
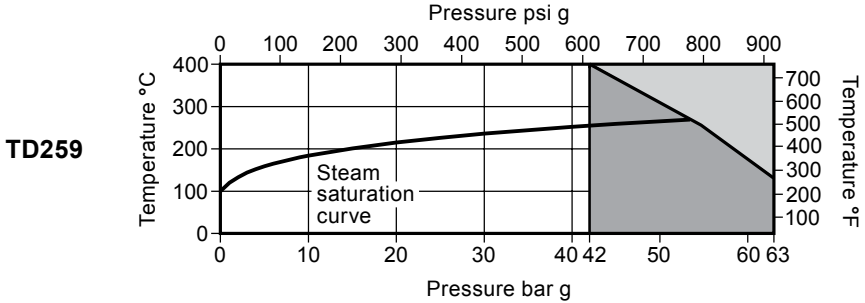

 The product **must not** be used in this region.

 For optimum product performance the PMO should not exceed 42 bar g (609 psi g).

Body design conditions		PN63	
PMA	Maximum allowable pressure	63 bar g @ 120°C	(914 psi g @ 248°F)
TMA	Maximum allowable temperature	<b>TD259</b>	400°C @ 42 bar g (752°F @ 609 psi g)
		<b>TD259A</b>	255°C @ 57 bar g (491°F @ 826 psi g)
Minimum allowable temperature		0°C	(32°F)
PMO	Maximum operating pressure	<b>TD259</b>	42 bar g @ 400°C (609 psi g @ 752°F)
		<b>TD259A</b>	42 bar g @ 255°C (609 psi g @ 491°F)
TMO	Maximum operating temperature	<b>TD259</b>	400°C @ 42 bar g (752°F @ 609 psi g)
		<b>TD259A</b>	255°C @ 42 bar g (491°F @ 609 psi g)
Minimum operating temperature		0°C	(32°F)
PMOB Maximum operating backpressure must not exceed 50% of the upstream pressure.			
Minimum operating differential pressure for satisfactory operation		0.25 bar	(3.6 psi)
Designed for a maximum cold hydraulic test pressure of:		24 bar g	(348 psi g)



---

## 3. Installation

---

**Note:** Before actioning any installation observe the 'Safety information' in Section 1.

Referring to the Installation and Maintenance Instructions, name-plate and Technical Information Sheet, check that the product is suitable for the intended installation:

- 3.1** Check materials, pressure and temperature and their maximum values. If the maximum operating limit of the product is lower than that of the system in which it is being fitted, ensure that a safety device is included in the system to prevent overpressurisation.
- 3.2** Determine the correct installation situation and the direction of fluid flow.
- 3.3** Remove protection covers from all connections and protective film from all name-plates, where appropriate, before installation on steam or other high temperature applications.
- 3.4** Always ensure the correct tools, safety procedures and protective equipment are used at all times.
- 3.5** The trap should be installed in the horizontal plane, preferably preceded by a small drop leg.
- 3.6** Suitable isolation valves must be installed to allow for safe maintenance and trap replacement.
- 3.7** Consideration should be given to a suitable method for testing the correct operation of the trap. This may be a sight glass or a Spiratec system. Sight glasses must be positioned a minimum of 1 m (3 ft) downstream of any blast-action traps. Where the trap discharges into a closed return system, a non-return valve should be fitted downstream to prevent return flow. Remove all packaging and protective covers and ensure all connection ports are clear from obstruction.
- 3.8** Always open isolation valves slowly until normal operating conditions are achieved - this will avoid system shocks. Check for leaks and correct operation.

**Note:** If the trap is to discharge to atmosphere ensure it is to a safe place, the discharging fluid may be at a temperature of 100°C (212°F).

---

## 4. Commissioning

---

After installation or maintenance ensure that the system is fully functional. Carry out tests on any alarms or protective devices.

---

## 5. Operation

---

The thermodynamic steam trap will discharge condensate with a blast type action at a few degrees below steam saturation temperature, due care must be given to the site of the discharge.

# 6. Maintenance

**Note:** Before actioning any maintenance programme observe the 'Safety information' in Section 1.

## 6.1 General maintenance

Before undertaking any maintenance on the trap it must be isolated from both the supply line and return line and any pressure allowed to safely normalise to atmosphere. The trap should then be allowed to cool. When reassembling, ensure that all joint faces are clean.

## 6.2 How to service:

- Remove the insulating cover (item 4, TD52M only), if fitted.
- Unscrew the cap (2) using a spanner. **Do not use** Stillsons or a wrench of similar type which may cause distortion of the cap.
- When reassembling, the disc (3) is normally placed in position with the grooved side in contact with the body seating face.
- Screw on the cap (2); no gasket is required but a fine smear of Molybdenum Disulphide grease should be applied to the threads. Tighten the cap (2) to the recommended tightening torque (see Table 1).

**Warning:**

When torquing or untorquing the cap (2), some support should be given to the body of the trap to prevent over stressing and/or distortion of the end connections and system pipework.

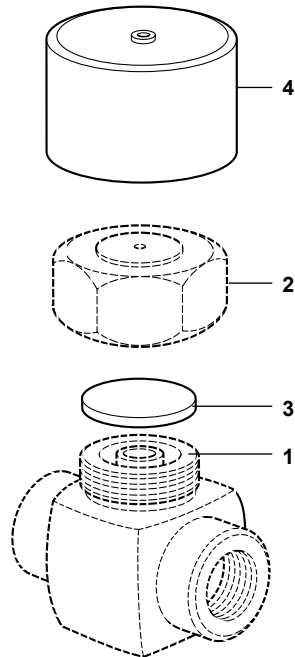



Fig. 4 TD52M shown

## Table 1 Recommended tightening torques

**Warning:**

When torquing or untorquing the cap (2), some support should be given to the body of the trap to prevent over stressing and/or distortion of the end connections and system pipework.

Trap	Item	 mm or 	N m	(lbf ft)
TD10	2	17 A/F	22 - 25	(16 - 18)
	2 (1/4")	36 A/F	180 - 200	(132 - 147)
	2 (3/8")	36 A/F	180 - 200	(132 - 147)
TD52M	2 (1/2")	36 A/F	180 - 200	(132 - 147)
	2 (3/4")	41 A/F	180 - 200	(132 - 147)
	2 (1")	55 A/F	250 - 275	(184 - 202)
TD259	2	36 A/F	135 - 150	(99 - 110)

# 7. Spare parts

The spare parts available are shown in heavy outline. Parts drawn in broken lines are not supplied as spares.

**Note:** There are no available spares for the TD10.

## TD52M available spares

	TD52M	(packet of 3)	<b>3</b>
Disc	TD52MLC	(packet of 3)	<b>3</b>
	TD52MA	(packet of 3)	<b>3</b>
	TD52MLCA	(packet of 3)	<b>3</b>
Insulating cover (not available for the 1" size)			<b>4</b>

## TD259 available spares

Disc	TD259	(packet of 3)	<b>3</b>
	TD259A	(packet of 3)	<b>3</b>

### How to order spares

Always order spares by using the description given in the column headed 'Available spares' and state the size, model number and type of trap.

**Example:** 1 - Packet of three discs for the TD259A thermodynamic steam trap.

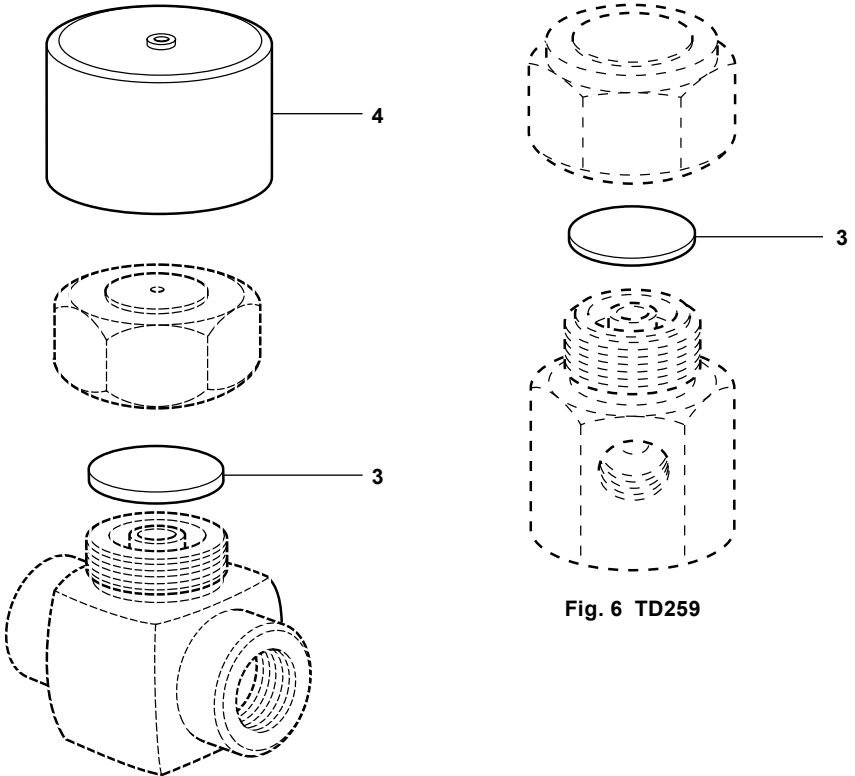

Fig. 5 TD52M

Fig. 6 TD259

