

TA10A and TA10P
Steam Tracing
Temperature Control Valves
Installation and Maintenance Instructions

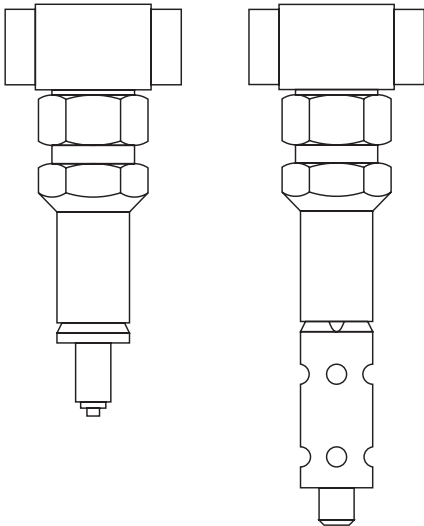

1. Safety information
2. General product information
3. Installation
4. Commissioning
5. Operation
6. Spare parts
7. Maintenance

1. Safety information

Safe operation of these products can only be guaranteed if they are properly installed, commissioned, used and maintained by qualified personnel (see Section 1.11) in compliance with the operating instructions. General installation and safety instructions for pipeline and plant construction, as well as the proper use of tools and safety equipment must also be complied with.

1.1 Intended use

Referring to the Installation and Maintenance Instructions, name-plate and Technical Information Sheet, check that the product is suitable for the intended use/application.

The products comply with the requirements of the European Pressure Equipment Directive 2014/68/EU and fall within category 'SEP'.

It should be noted that products within this category are required by the directive not to carry the  mark.

- i) The products have been specifically designed for use on steam, water, compressed air and other non-hazardous fluids which are in Group 2 of the above mentioned Pressure Equipment Directive. The products' use on other fluids may be possible but, if this is contemplated, Spirax Sarco should be contacted to confirm the suitability of the product for the application being considered.
- ii) Check material suitability, pressure and temperature and their maximum and minimum values. If the maximum operating limits of the product are lower than those of the system in which it is being fitted, or if malfunction of the product could result in a dangerous overpressure or overtemperature occurrence, ensure a safety device is included in the system to prevent such over-limit situations.
- iii) Determine the correct installation situation and direction of fluid flow.
- iv) Spirax Sarco products are not intended to withstand external stresses that may be induced by any system to which they are fitted. It is the responsibility of the installer to consider these stresses and take adequate precautions to minimise them.
- v) Remove protection covers from all connections before installation.

1.2 Access

Ensure safe access and if necessary a safe working platform (suitably guarded) before attempting to work on the product. Arrange suitable lifting gear if required.

1.3 Lighting

Ensure adequate lighting, particularly where detailed or intricate work is required.

1.4 Hazardous liquids or gases in the pipeline

Consider what is in the pipeline or what may have been in the pipeline at some previous time. Consider: flammable materials, substances hazardous to health, extremes of temperature.

1.5 Hazardous environment around the product

Consider: explosion risk areas, lack of oxygen (e.g. tanks, pits), dangerous gases, extremes of temperature, hot surfaces, fire hazard (e.g. during welding), excessive noise, moving machinery.

1.6 The system

Consider the effect on the complete system of the work proposed. Will any proposed action (e.g. closing isolation valves, electrical isolation) put any other part of the system or any personnel at risk?

Dangers might include isolation of vents or protective devices or the rendering ineffective of controls or alarms. Ensure isolation valves are turned on and off in a gradual way to avoid system shocks.

1.7 Pressure systems

Ensure that any pressure is isolated and safely vented to atmospheric pressure. Consider double isolation (double block and bleed) and the locking or labelling of closed valves. Do not assume that the system has depressurised even when the pressure gauge indicates zero.

1.8 Temperature

Allow time for temperature to normalise after isolation to avoid danger of burns.

1.9 Tools and consumables

Before starting work ensure that you have suitable tools and /or consumables available. Use only genuine Spirax Sarco replacement parts.

1.10 Protective clothing

Consider whether you and/or others in the vicinity require any protective clothing to protect against the hazards of, for example, chemicals, high/low temperature, radiation, noise, falling objects, and dangers to eyes and face.

1.11 Permits to work

All work must be carried out or be supervised by a suitably competent person. Installation and operating personnel should be trained in the correct use of the product according to the Installation and Maintenance Instructions.

Where a formal 'permit to work' system is in force it must be complied with. Where there is no such system, it is recommended that a responsible person should know what work is going on and, where necessary, arrange to have an assistant whose primary responsibility is safety. Post 'warning notices' if necessary.

1.12 Handling

Manual handling of large and/or heavy products may present a risk of injury. Lifting, pushing, pulling, carrying or supporting a load by bodily force can cause injury particularly to the back. You are advised to assess the risks taking into account the task, the individual, the load and the working environment and use the appropriate handling method depending on the circumstances of the work being done.

1.13 Residual hazards

In normal use the external surface of the product may be very hot. If used at the maximum permitted operating conditions the surface temperature of some products may reach temperatures of 350 °C. Many products are not self-draining. Take due care when dismantling or removing the product from an installation (refer to 'Maintenance instructions').

1.14 Freezing

Provision must be made to protect products which are not self-draining against frost damage in environments where they may be exposed to temperatures below freezing point.

1.15 Disposal

Unless otherwise stated in the Installation and Maintenance Instructions, this product is recyclable and no ecological hazard is anticipated with its disposal providing due care is taken.

Please visit the Spirax Sarco product compliance web pages

<https://www.spiraxsarco.com/product-compliance>

for up to date information on any substances of concern that may be contained within this product. Where no additional information is provided on the Spirax Sarco product compliance web page, this product may be safely recycled and/or disposed providing due care is taken. Always check your local recycling and disposal regulations.

1.16 Returning products

Customers and stockists are reminded that under EC Health, Safety and Environment Law, when returning products to Spirax Sarco they must provide information on any hazards and the precautions to be taken due to contamination residues or mechanical damage which may present a health, safety or environmental risk. This information must be provided in writing including Health and Safety data sheets relating to any substances identified as hazardous or potentially hazardous.

2. General product information

Description

The TA10A and TA10P are stainless steel self-powered temperature control valves, which have been specifically designed for steam tracing applications, but can also be used for other applications such as tank heating.

Available types:

TA10A	For air temperature sensing.
TA10P	Immersion /remote sensor for product sensing. Note: the TA10P is supplied with a 1 m capillary tube for remote sensing.

Temperature ranges:

Range 1	0 °C to 50 °C (TA10A and TA10P)
Range 2	20 °C to 70 °C (TA10P only)

Note: The maximum temperature overrun is 50 °C

Technical data

Proportional band	15 °C
-------------------	-------

Note: The TA10 is calibrated so that it is fully closed at set point.

Sizes and pipe connections

½" and ¾" screwed BSP T Rp (ISO 7-1) or NPT.

Pressure/temperature limits

Body design conditions	PN25
PMA Maximum allowable pressure	25 bar g
TMA Maximum allowable temperature	200 °C
Minimum allowable temperature	0 °C
PMO Maximum operating pressure for saturated steam service	14.6 bar g
Maximum operating pressure for saturated steam service	
TMO Maximum operating temperature	200 °C
Minimum operating temperature	0 °C
Note: For lower operating temperatures consult Spirax Sarco.	
Δ PMX Maximum differential pressure	10 bar g
Designed for a maximum cold hydraulic test pressure of:	38 bar

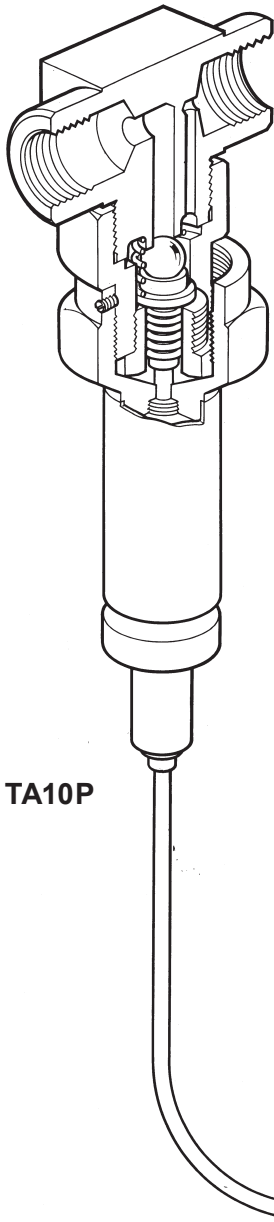

TA10P

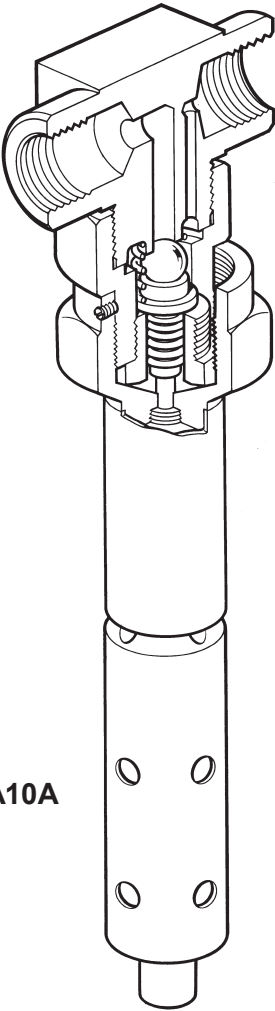

TA10A

TA10A and TA10P Steam Tracing Temperature Control Valves

3. Installation

Note: Before actioning any installation observe the 'Safety information' in Section 1.

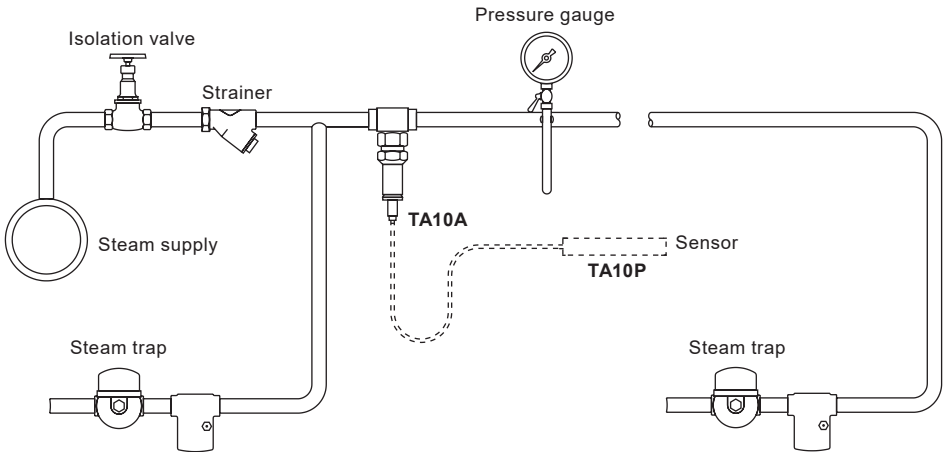

Fig. 2 Typical application

- 3.1** Ensure all pipework is cleaned out before installing the valve. It is recommended that a strainer is fitted before the valve (see Figure 2).
- 3.2** Ensure the valve is fitted with the flow arrow pointing in the right direction.
- 3.3** The valve bonnet should always lie below the centre line of the valve body - preferably vertically downwards.
- 3.4** **For the TA10P version only**, the capillary tube must always be installed with a degree of 'slack' so as not to restrict the overrun movement of the actuator. The sensor should be strapped to the outside of the pipe or vessel being controlled (see Figure 3).

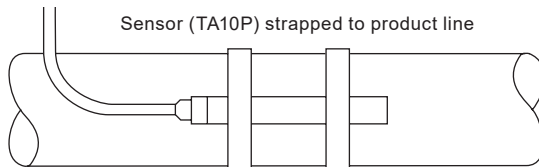

Fig. 3 Sensor strapped to product line

- 3.5** Ensure all pipework is cleaned out before installing the valve. It is recommended that a strainer is fitted before the valve (see Figure 2).

4. Commissioning

It is accepted that all normally established safety procedures will be adhered to when operating steam systems.

- 4.1 Open the steam supply to the TA10 valve.
- 4.2 Allow the valve body to warm up for a period of approximately 30 minutes with steam passing.
- 4.3 With reference to Figure 4, screw the adjustment head all the way on (clockwise) until it contacts the stop face on the bonnet.

This is the lowest temperature of the adjustment range. Screw back from the stop, at the rate of 20 °C for one complete revolution or 3J °C for each hexagon 'flat', the amount required to achieve the desired set temperature. Finer adjustment may be required once the conditions have stabilised at the required temperature. Finally lock the adjustment with the grub screw.

- 4.4 As an alternative to the procedure in Section 4.3 (Note: a test point or pressure gauge will be required): Gradually unscrew the adjustment head until the valve just begins to open (check test point).

This setting then relates to the prevailing ambient or product temperature. Knowing the prevailing temperature, the control can then be readjusted to the required set temperature at the same rate as 4.3 above. Finer adjustment may be required once the conditions have stabilised at the required temperature. Finally lock the adjustment with the grub screw.

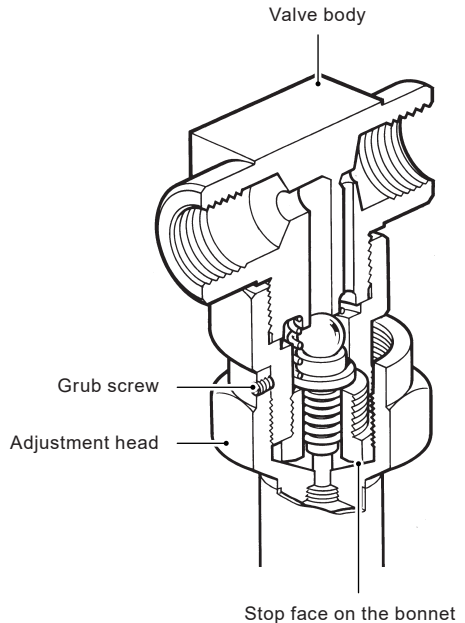

5. Operation

Raising the temperature of the sensor will cause the control system to expand thereby applying a closing force to the valve seat. Should the temperature continue to rise above the set point, an inbuilt overrun device will provide substantial protection for the control system.

Cooling the sensor will cause the control system to contract allowing the valve to open under the control of a return spring. Should a leak develop in the control system the same return spring will ensure the valve fails in the open position.

6. Spare parts

The spare parts available are shown in solid outline. Parts drawn in broken line are not supplied as spares.

Available spares

Internal assembly	A, B, C
Control system (State type and range)	D

How to order spares

Always order spares by using the description given in the column headed 'Available spares' and state the size and type of control.

Example: 1 - Internal assembly for a Spirax Sarco 1/2" TA10P steam tracing temperature control valve.

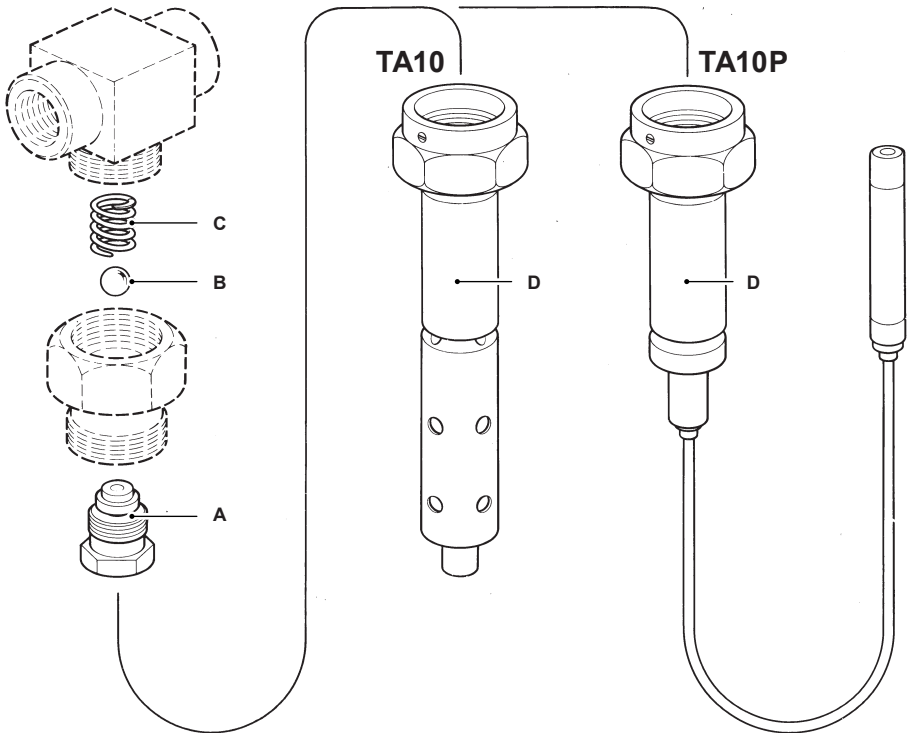

Fig. 5

7. Maintenance

Note: Before actioning any maintenance programme observe the 'Safety information' in Section 1.

How to fit

- Isolate the control and remove the control system by withdrawal of the grub screw from the adjustment head, followed by unscrewing the adjustment head from the valve.
- Unscrew the pilot seal assembly (item A) from the bonnet. Do not remove from the bonnet unless the ball and spring (items B and C) cannot easily be withdrawn.
- Replace with new parts. Apply proprietary sealing compound sparingly to threaded parts, and reassemble. Tighten to torques shown in Table 1.
- Screw on the adjustment head of the control system and follow the procedure in Section 4 for bringing the temperature control valve back into service.

Table 1 Recommended tightening torques

Assembly items	Torque N m
Bonnet /body	190 ± 10
Bellows seal assembly/bonnet	115 ± 5

