

SX80 and SX90
Quickstart Guide
Installation and Maintenance Instructions



Contents

1. Safety information	
------------------------------	--

2. General product information	13
2.1 General description	
2.2 Front panel	14
2.3 Switching on	
2.4 Quick code	16
2.5 Home display	18
2.6 Quick code functions	20

3. Installation	23
3.1 Unpacking the controller	
3.2 Mechanical installation	25
3.3 Environmental conditions	26
3.4 Electrical installation	27

4. Commissioning	42
4.1 Operation	
4.2 Operator Level 2	43
4.3 Level 2 parameters	44

5. Maintenance	47
-----------------------	-----------

1. Safety information

Safe operation of this product can only be guaranteed if it is properly installed, commissioned, used and maintained by qualified personnel (see Section 1.11) in compliance with the operating instructions. General installation and safety instructions for pipeline and plant construction, as well as the proper use of tools and safety equipment must also be complied with.

Safety and EMC protection can seriously be impaired if the unit is not used in the manner specified. It is the responsibility of the installer to ensure the safety and EMC of the installation.

Safety

This instrument complies with the European Low Voltage Directive 73/23/EEC, by the application of the safety standard EN 61010.

Unpacking and storage

If on receipt, the packing or unit is damaged do not install but contact your supplier. If the unit is being stored before use, protect it from humidity and dust within an ambient temperature range of -30°C to +75°C.

Electrostatic discharge precautions

Always observe all electrostatic precautions before handling the unit.

Service and repair

This instrument has no user serviceable parts. Contact your supplier for repair.

Cleaning

Isopropyl alcohol may be used to clean labels. Do not use water or water based products. A mild soap solution may be used to clean other exterior surfaces.



Electromagnetic compatibility

This instrument conforms with the essential protection requirements of the EMC Directive 89/336/EEC, by the application of a Technical Construction File. It satisfies the general requirements of the industrial environment defined in EN 61326.

Caution - Charged capacitors

Before removing an instrument from its sleeve, disconnect the supply and wait at least two minutes to allow capacitors to discharge. Avoid touching the exposed electronics of an instrument when withdrawing it from the sleeve.

Safety symbols used on the instrument have the following meaning:

	Caution, refer to throughout accompanying documents.		Equipment protected by double insulation.
---	--	---	---

Installation category and pollution degree

This unit has been designed to conform to BS EN 61010 installation Category II and Pollution Degree 2, defined as follows: Installation Category II (CAT II) – The rated impulse voltage for equipment on nominal 230 V supply is 2500 V.

Pollution Degree 2 – Normally only non-conductive pollution occurs. However, a temporary conductivity caused by condensation must be expected.

Personnel

Installation must be carried out by suitably qualified personnel.

Enclosure of live parts

To prevent hands or metal tools touching parts that may be electrically live, the controller must be installed in an enclosure.

Caution - Live sensors

The controller is designed to operate if the temperature sensor is connected directly to an electrical heating element. However, you must ensure that service personnel do not touch connections to these inputs while they are live. With a sensor, all cables, connectors and switches for connecting the sensor must be mains rated for use in 240 Vac CAT II.

Wiring

It is important to connect the unit in accordance with the data within this document ensuring that the protective earth connection is **ALWAYS** fitted first and disconnected last. Wiring must comply with all local wiring regulations, i.e. UK, the latest IEE wiring regulations, (BS 7671), and USA, NEC Class 1 wiring methods.



Do not connect the ac supply to the low voltage sensor input or low level inputs and outputs.

Voltage rating

The maximum continuous voltage applied between any of the following terminals must not exceed 240 Vac:

- Relay output to logic, dc or sensor connections.
- Any connection to ground.

Warning: The controller must not be wired to a three phase supply with an unearthed star connection. Under fault conditions such a supply could rise above 240 Vac with respect to ground and the product would not be safe.

Conductive pollution

Electrically conductive pollution i.e. carbon dust, **MUST** be excluded from the enclosure in which the controller is installed. To secure a suitable atmosphere in conditions of conductive pollution, fit an air filter to the air intake of the enclosure. Where condensation is likely, include a thermostatically controlled heater in the enclosure.

Grounding of the temperature sensor shield

In some installations it is common practice to replace the temperature sensor while the controller is still powered up. Under these conditions, as additional protection against electric shock, we recommend that the shield of the temperature sensor is ground. Do not rely on grounding through the framework of the machine.

Overtemperature protection

To prevent overheating of the process under fault conditions, a separate overtemperature protection unit should be fitted which will isolate the heating circuit. This must have an independent temperature sensor.

Note: Alarm relays within the unit will not give protection under all failure conditions.

Installation requirements for EMC

To comply with European EMC directive certain installation precautions are necessary:

Relay outputs – It may be necessary to fit a suitable filter to suppress conducted emissions.

Filter requirements depend on the type of load. Typical applications may use Schaffner FN321 or FN612.

Restriction of Hazardous Substances (RoHS)

Table 1 Restricted materials table

Product	Toxic and hazardous substances and elements					
	Pb	Hg	Cd	Cr VI)	PBB	PBDE
SX80 and SX90						
PCBA	X	O	X	O	O	O
Enclosure	O	O	O	O	O	O
Display	O	O	O	O	O	O
O	Indicates that this toxic or hazardous substance contained in all homogeneous material for this part is below the limit requirement in SJ/T11363-2006.					
X	Indicates that this toxic or hazardous substance contained in at least one of the homogeneous material for this part is above the limit requirement in SJ/T11363-2006.					

Approval

Name:	Position:	Signature:	Date:
Martin Greenhalgh	Quality Manager		20 th APRIL 2008

1.1 Intended use

- i) Check that the product is suitable for its intended application.
- ii) Check material suitability, pressure and temperature and their maximum and minimum values. If the maximum operating limits of the product are lower than those of the system in which it is being fitted, or if malfunction of the product could result in a dangerous overpressure or overtemperature occurrence, ensure a safety device is included in the system to prevent such over-limit situations.
- iii) Determine the correct installation situation and direction of fluid flow.
- iv) Spirax Sarco products are not intended to withstand external stresses that may be induced by any system to which they are fitted. It is the responsibility of the installer to consider these stresses and take adequate precautions to minimize them.
- v) Remove protection covers from all connections and protective film from all name-plates, where appropriate, before installation on steam or other high temperature applications.

1.2 Access

Ensure safe access and if necessary a safe working platform (suitably guarded) before attempting to work on the product. Arrange suitable lifting gear if required.

1.3 Lighting

Ensure adequate lighting, particularly where detailed or intricate work is required.

1.4 Hazardous liquids or gases in the pipeline

Consider what is in the pipeline or what may have been in the pipeline at some previous time. Consider: flammable materials, substances hazardous to health, extremes of temperature.

1.5 Hazardous environment around the product

Consider: explosion risk areas, lack of oxygen (e.g. tanks, pits), dangerous gases, extremes of temperature, hot surfaces, fire hazard (e.g. during welding), excessive noise, moving machinery.

1.6 The system

Consider the effect on the complete system of the work proposed. Will any proposed action (e.g. closing isolation valves, electrical isolation) put any other part of the system or any personnel at risk? Dangers might include isolation of vents or protective devices or the rendering ineffective of controls or alarms. Ensure isolation valves are turned on and off in a gradual way to avoid system shocks.

1.7 Pressure systems

Ensure that any pressure is isolated and safely vented to atmospheric pressure. Consider double isolation (double block and bleed) and the locking or labeling of closed valves. Do not assume that the system has depressurized even when the pressure gauge indicates zero.

1.8 Temperature

Allow time for temperature to normalize after isolation to avoid the danger of burns.

If the instrument is to be stored before use, protect from humidity and dust in an ambient temperature of $-30\text{ }^{\circ}\text{C}$ to $+75\text{ }^{\circ}\text{C}$.

1.9 Tools and consumables

Before starting work ensure that you have suitable tools and/or consumables available. Use only genuine Spirax Sarco replacement parts.

1.10 Protective clothing

Consider whether you and/or others in the vicinity require any protective clothing to protect against the hazards of, for example, chemicals, high/low temperature, radiation, noise, falling objects, and dangers to eyes and face.

1.11 Permits to work

All work must be carried out or be supervised by a suitably competent person. Installation and operating personnel should be trained in the correct use of the product according to the Installation and Maintenance Instructions. Where a formal 'permit to work' system is in force it must be complied with. Where there is no such system, it is recommended that a responsible person should know what work is going on and, where necessary, arrange to have an assistant whose primary responsibility is safety. Post 'warning notices' if necessary.

1.12 Handling

Manual handling of large and/or heavy products may present a risk of injury. Lifting, pushing, pulling, carrying or supporting a load by bodily force can cause injury particularly to the back. You are advised to assess the risks taking into account the task, the individual, the load and the working environment and use the appropriate handling method depending on the circumstances of the work being done.

1.13 Residual hazards

In normal use the external surface of the product may be very hot. Many products are not self-draining. Take due care when dismantling or removing the product from an installation.

1.14 Freezing

Provision must be made to protect products that are not self-draining against frost damage in environments, where they may be exposed to temperatures below freezing point.

1.15 Disposal

On disposal of the unit or component, appropriate precautions should be taken in accordance with Local/National regulations. Unless otherwise stated in the Installation and Maintenance Instructions this product is recyclable and no ecological hazard is anticipated with its disposal providing due care is taken.

Please visit the Spirax Sarco product compliance web pages
<https://www.spiraxsarco.com/product-compliance>

for up to date information on any substances of concern that may be contained within this product. Where no additional information is provided on the Spirax Sarco product compliance web page, this product may be safely recycled and/or disposed providing due care is taken. Always check your local recycling and disposal regulations.

1.16 Returning products

Customers and stockists are reminded that under EC Health, Safety and Environment Law, when returning products to Spirax Sarco they must provide information on any hazards and the precautions to be taken due to contamination residues or mechanical damage which may present a health, safety or environmental risk. This information must be provided in writing including Health and Safety data sheets relating to any substances identified as hazardous or potentially hazardous.

2. General product information

2.1 General description

The SX series provide precise control of temperature or pressure in industrial processes and is available in two standard sizes:

- 1/16 DIN model number SX80
- 1/8 DIN model number SX90

They are suitable for both single and multiple Set Point applications utilising the Spirax Sarco range of pneumatic or electric control valves and electrical and electropneumatic instruments. A universal input accepts various thermocouples, RTDs or process inputs. Up to three (SX80) or six (SX90) outputs can be configured for control, alarm or retransmission purposes. Digital communication is included in the SX90 only. Quick start codes are featured for ease of commissioning.

General specification

Operating ambient temperature	0°C to 55°C (32°F to 131°F) and RH: 5 to 85% non-condensing
Panel sealing	IP65, plug in from front panel
Atmospheres	Not suitable for use above 2000 m or in explosive or corrosive atmospheres





Note: For details not covered in this user guide, a detailed engineering manual and other related literature can be downloaded from:

www.spiraxsarco.com

2.2 Front panel



Fig. 1

Button	Meaning
	<p>From any display – press to return to the HOME display</p>
	<p>Press to select a new parameter. Hold down to continuously scroll through parameters</p>
	<p>Press to decrease a value</p>
	<p>Press to increase a value</p>

2.3 Switching on

If the controller has not previously been configured it will start up, showing the 'Quick Configuration' codes.

The quick code consists of 5 characters in the format 12345. This allows input and output functionality to be configured as shown in Section 2.4.



Incorrect configuration can result in damage to the process and / or personal injury and must be carried out by a competent person authorized to do so. It is the responsibility of the person commissioning the controller to ensure the configuration is correct.

If the controller has been previously configured using the Quick Codes, it will start up showing the 'HOME' display shown in Section 2.5.

2.4 Quick code

When first switched on the characters are shown as: XXXXX.

- The first character defines the input type.
- The second character defines the control type and hence the output type.
- The third character defines the function of the alarm relay.
- The fourth character defines the function of Output 4 for the SX90.
- The fifth character defines the language used for User Messages.

Note: See Section 2.6 for the functions of the characters.

Note: An X indicates that the option is not fitted.

To adjust them, follow these steps:

1. Press any button. The first character will change to a flashing – (dash).
2. Press the ▲ or ▼ buttons to change the flashing character to the required code shown in the Quick Code functions – see the Table in Section 2.6.
3. Press the ⏪ button to scroll to the next character.
If you need to return to the first character press the ⏩ button.
4. When all five characters have been configured press the ⏹ button again - The display will show:



Press the ▲ or ▼ buttons to get to this display screen:



The controller will then automatically start in Operator Level 1.

2.5 Home display

The home display is the default start screen if the Quick Codes have been previously configured.

Display layout for the SX80 and SX90

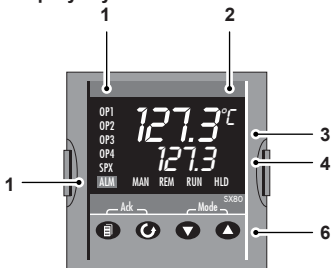

Fig. 2 SX80



Fig. 3 SX90

Descriptions

1 Beacons	ALM	Alarm active (Red)
	OP1	Lit when output 1 is ON - heat or raise
	OP2	Lit when output 2 is ON - cool or lower
	OP3	Not used
	OP4	
	SPX	Alternative Set Point in use (SP2 or SP3)
	REM	Remote Set Point or communications active
	RUN	Soft start timer running
	'RUN'	Flashing - Soft start timer in hold
	MAN	Manual mode selected
2	-	Units (if configured)
3	-	Measured value (Temperature or Pressure)
4	-	Target temperature or pressure (Set Point) by default
5	-	Meter (SX90 only) defaults to valve position if the quick code 2 is D, V or B. Defaults to Heat/Cool (centre zero) if quick code 2 is A or H.
6	-	Operator buttons

2.6 Quick code functions

See Section 2.4 for details on the Quick Code.

2.6.1 Quick code - Character 1

Function – Input type and range

P	Pt100 RTD	99.9°C to 300.0°C
0	4 - 20 mA	0 to 1.6 bar
1	4 - 20 mA	0 to 2.5 bar
2	4 - 20 mA	0 to 4.0 bar
3	4 - 20 mA	0 to 6.0 bar
4	4 - 20 mA	0 to 10 bar
5	4 - 20 mA	0 to 16 bar
6	4 - 20 mA	0 to 25 bar
7	4 - 20 mA	0 to 40 bar
8	4 - 20 mA	-50 to +500 °C
9	4 - 20 mA	0 to +100 °C
K	K t/c	-200°C to +1372°C

2.6.2 Quick code - Character 2

Function – Control and output type

D	Boundless VP, on OP3/4 (SX80) Boundless VP, on OP5/6 (SX90)	Alarm relay on IO1 (SX80 and SX90)
V	SX90 only Bounded VP on OP5/6	Alarm relay on IO1. Analogue feedback
P	SX90 only Bounded VP on OP5/6	Alarm relay on IO1. Potentiometer feedback
A	SX90 only Analogue Heat/Cool PID output on OP2/OP3	Alarm relay on IO1. Alarm relay on OP4
H	Analogue Heat only PID output on OP2 (SX80) OP2 tracks OP3 (SX90)	Alarm relay on IO1. Alarm relay on OP4
S	Analogue OP PID heat only, split output on OP2/OP (only SX90)	Alarm relay on IO1. Alarm relay on OP4

2.6.3 Quick code - Character 3

Function – IO1 alarm relay

X Unconfigured

0	Full scale high	Manual latching
1	Full scale low	
2	Deviation high	
3	Deviation low	
4	Deviation band	

2.6.4 Quick code - Character 4

Function – OP4 alarm relay (not if SX80 and VP)

X Unconfigured

0	Full scale high	Manual latching
1	Full scale low	
2	Deviation high	
3	Deviation low	
4	Deviation band	

2.6.5 Quick code - Character 5

Function – Language selection

E	English
F	Français
S	Español
I	Italiano
G	Deutsch

3. Installation

Note: Read the 'Safety information' in Section 1 before installing the product.

Referring to the Installation and Maintenance Instructions, name-plate and Technical Information Sheet, check that the product is suitable for the intended installation.

3.1 Unpacking the controller

To remove the controller from its sleeve, ease the latching ears (1) outwards and pull the controller forward. When plugging back in ensure that the latching ears click into place to maintain the IP65 sealing.

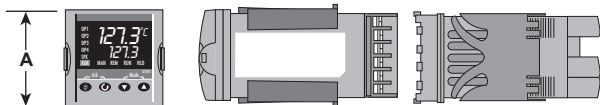

Fig. 4a SX80

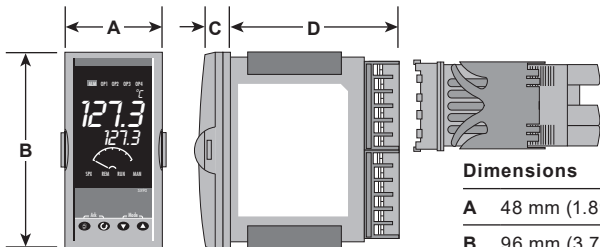

Fig. 5a SX90

Dimensions

A	48 mm (1.89")
B	96 mm (3.78")
C	11 mm (0.44")
D	90 mm (3.54")

Parts

- 1 Latching ears
- 2 IP65 Sealing Gasket
- 3 Panel retaining clips
- 4 Sleeve

Also supplied are: 2 x 2.49 Ω resistors 1 x Snubber

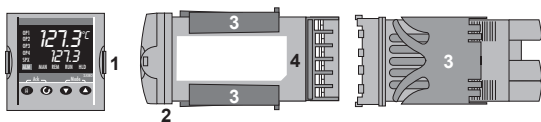

Fig. 4b SX80

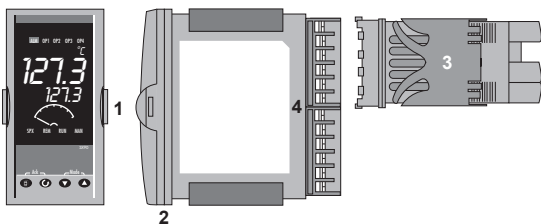

Fig. 5b SX90

3.2 Mechanical installation

Installation on a panel cut out:

- Cut the panel to the size shown (see Figure 6).
- Fit the IP65 sealing gasket behind the front bezel of the controller.
- Insert the controller in its sleeve through the cut-out.
- Spring the panel retaining clips into place.
- Secure the controller in position by holding it level and pushing both retaining clips forward.
- Peel off the protective cover from the display.

Panel cut-out dimensions

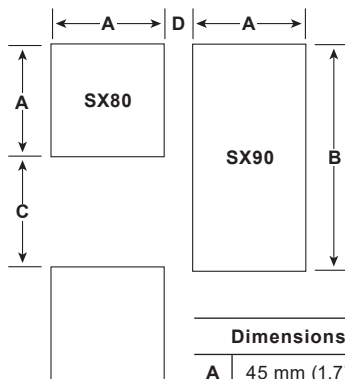

Note:

Cut-out dimensions are recommended minimum spacing (not to scale).

Panel dimensions

	Dimensions	Tolerance	Weight
A	45 mm (1.77")	-0.00 +0.6	250 g (8.82 oz)
B	92 mm (3.62")	-0.00 +0.8	
C	38 mm (1.50")		
D	10 mm (0.40")		

Fig. 6

3.3 Environmental conditions

This instrument is intended for permanent installation, for indoor use only, and to be enclosed in an electrical panel.

Install the product in an environment that minimises the effects of heat, vibration, shock and electrical interference (see Section 1 'Safety information').

3.4 Electrical installation

Note: Before installing read the 'Safety information' in Section 1.



Warning:

Isolate the mains supply before touching any of the wiring terminals as these may be wired to hazardous voltages.

Use only the connectors supplied with the product, or spares obtained from Spirax Sarco Limited. Use of different connectors may compromise product safety and approvals.

Ensure there is no condensation within the unit before installing and connecting the power.

3.4.1 Wiring

The screw terminals accept wire sizes from 0.5 to 1.5 mm (16 to 22 AWG). Hinged covers prevent hands or metal making accidental contact with live wires. The rear terminal screws should be tightened to 0.4 Nm (3.5 lbf in).

3.4.2 SX80 controller

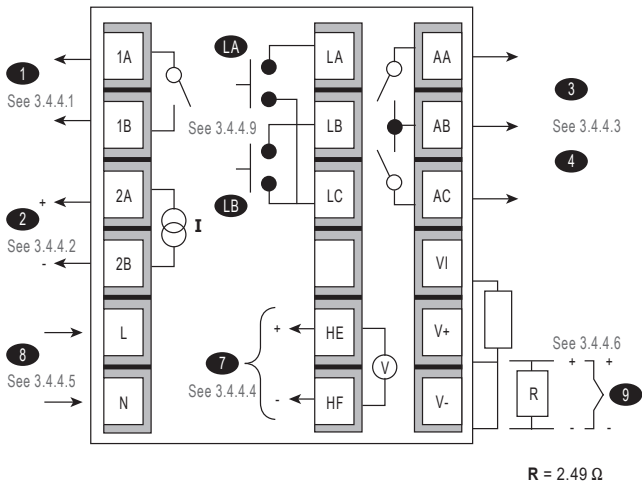

3.4.3 SX90 controller

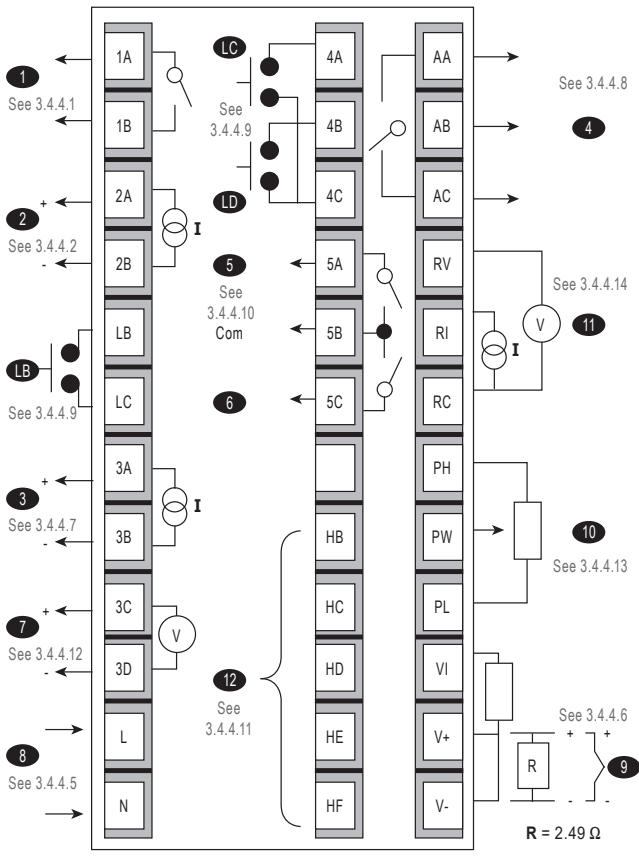

SX80 and SX90 Quickstart Guide

3.4.4 Inputs and outputs

Relays and inductive loads

Note: When switching inductive loads such as contactors or solenoid valves, wire the 22 nF/100 Ω . 'Snubber' supplied across the normally open relay terminals. This will prolong contact life and reduce interference.



Warning : Snubbers pass 0.6 mA at 110 V and a 1.2 mA at 230 Vac, which may be sufficient to hold on high impedance loads. Do not use in these installations.

3.4.4.1 Relay output (IO1) ①

Included on both SX80 and SX90 controllers. Output 1 is supplied as standard as a normally open relay configured for temperature alarm. For alarm type, see Quick Code Set 3.

- Isolated output 240 Vac.
- Contact rating 2 A 264 Vac resistive.

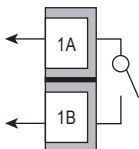

3.4.4.2 Output 2 (OP2) 4 – 20 mA ②

Included on both SX80 and SX90 controllers. Output 2 is supplied as standard as a 4 – 20 mA analogue output. For functionality see Quick Code Set 2.

- Isolated output 240 Vac.
- Configurable 0 – 20 mA or 4 - 20 Ma.

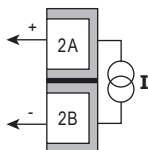

3.4.4.3 Output 3 and 4 (OP3/4) 3 4

Included on SX80 controllers only
Outputs 3 and 4 are normally open (Form A) relays which share a common connection. They are intended to control motor driven valves. For function see Quick Code set 2.

- Isolated output 240 Vac.

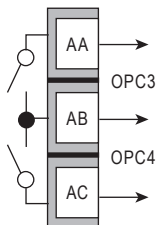

3.4.4.4 Transmitter power 7

Supply SX80

The transmitter power supply provides an 18 V supply to power an external transmitter.

- Isolated output 240 Vac.
- Output 18 V \pm 15%, 30 Ma.

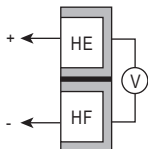

3.4.4.5 Power supply



8

Ensure that you have the correct supply for your controller:

1. Check order code of the controller supplied.
2. Use copper conductors only.
3. The power supply input is not fuse protected. This should be provided externally.

Safety requirements for permanently connected equipment state:

- A switch or circuit breaker shall be included in the building installation.
- It shall be in close proximity to the equipment and within easy reach of the operator.
- It shall be marked as the disconnecting device for the equipment.

Note: a single switch or circuit breaker can drive more than one instrument:

- High voltage supply: 100 to 240 Vac, -15%, +10%, 48 to 62 Hz SX80 6 Watts.
- SX90 9 W. Recommended external fuse ratings are: - Fuse type: T rated 2 A 250 V.

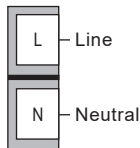

3.4.4.6 Sensor input 9

SX80 and SX90

Do not run input wires with power cables.

When shielded cable is used, it should be grounded at one point only.

Any external components (such as zener barriers) connected between sensor and input terminals may cause errors in measurement due to excessive and / or unbalanced line resistance, or leakage currents.

Sensor input not isolated from the logic outputs and digital inputs.

Thermocouple Type K

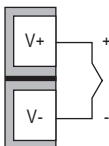

Use the correct compensating cable (preferably shielded).

RTD

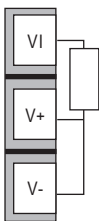

The resistance of the tree wires must be the same. The line resistance may cause errors if it exceeds 22 Ω .
V - Lead compensation
V+ and VI PRT.

Linear mA or mV

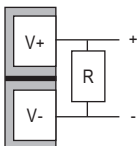

-10 to +80 mV
For mA input only connect the 2.49 Ω . (R) resistor supplied between the V+ and V- terminals as shown.

3.4.4.7 Output 3 (OP3) 4 – 20 mA 3

SX90 only

OP3 is a 4 – 20 mA analogue output in SX90 only.
For functionality see Quick Code, Code 2.

- Isolated output 240 Vac.
- Configurable 0 - 20 mA or 4 - 20 mA.

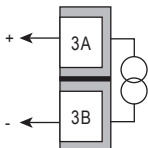

3.4.4.8 Output 4 (OP4) 4

SX90 only

Output 4 is a changeover (Form C) relay fitted in SX90 controllers.
For functionality see Quick Start, Code 4.

- Isolated output 240 Vac.
- Contact rating: 2 A 264 Vac resistive.

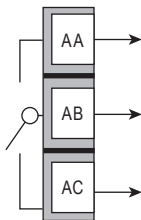

3.4.4.9 Digital inputs B, C and D **LA** **LB** **LC** **LD**

These are volt free contact closure inputs which may be used for Auto/Manual select or alarm acknowledgement.

For functionality refer to the Engineering Manual and Quick Code Set 2.

SX80 only

- LA and LB not isolated from each other.
- Not isolated from the sensor input.
- Switching: LA/LB 12 Vdc at 6 mA maximum.
- Contact open $>1200/\Omega$, Contact closed $< 300 \Omega$.

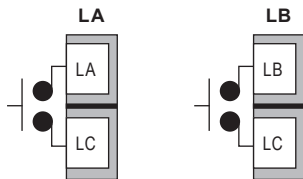

3.4.4.9 Digital inputs B, C and D (continued) **LA** **LB** **LC** **LD**

SX90 only

- LC and LD not isolated from each other.
- Not isolated from the sensor input.
- Switching: LC/LD 12 Vdc at 6 mA maximum LB 12 Vdc at 12 mA.
- Contact open $>1200/\Omega$,
Contact closed $<300 \Omega$.

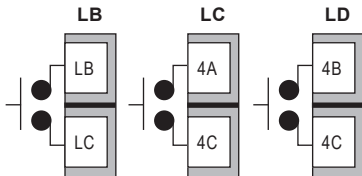

3.4.4.10 Outputs 5 and 6 (OP5/6) **5** **6**

SX90 only

Outputs 5 and 6 are supplied as normally open (Form A) relays and are to control motor driven valves.

They share a common connection and are, therefore, not isolated from each other.

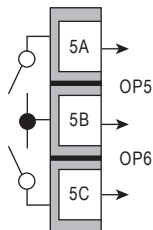

For alarm type see Quick Code, Code 3

- Contact rating: 2 A 264 Vac resistive – any terminal limited to 2 A.
- Isolated output 240 Vac.

3.4.4.11 Digital communications **12**

SX90 only

Digital communications uses Modbus protocol. It is available in SX90 only as EIA422 (EIA485 5-Wire).

- EIA422 or EIA485 (5-wire).
- Isolated 240 Vac.

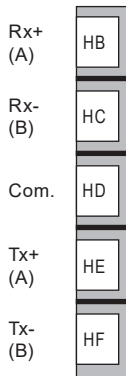

3.4.4.12 Transmitter power supply 7

SX90 only

The transmitter power supply provides a supply to power an external transmitter.

- Isolated output 240 Vac.
- Output 24 V +10%, 30 mA.

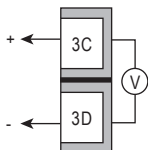

3.4.4.13 Potentiometer input 10

SX90 only

The potentiometer input provides feedback of the valve position:

- Potentiometer resistance: 100 – 10 k Ω .
- Excitation voltage: 0.46 to 0.54 V.
- Short circuit detection: <25 Ω .
- Open circuit detection: >2M Ω .
- Open circuit wiper detection >5M Ω .

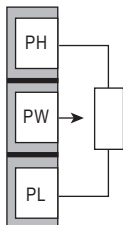

3.4.4.14 Remote Set Point input 11

SX90 only

- There are two inputs; 4 – 20 mA (terminals RC and R) and 0-10 Volts (terminals RC and RV).
- It is not necessary to fit an external burden resistor to the 4 – 20 mA input.
- C = Common.
- Isolated 240 Vac.

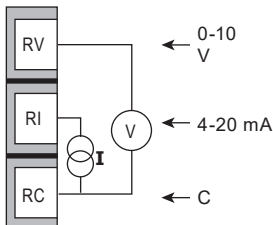

3.4.5 Connection of a pressure transmitter

When using a loop powered pressure sensor like the Spirax Sarco follow the wiring diagrams below for correct installation (SX80 below and SX90 opposite). We recommend connecting the sensor using an instrument grade shielded cable for optimum performance.

Wiring diagram for connecting the transmitter SX80:

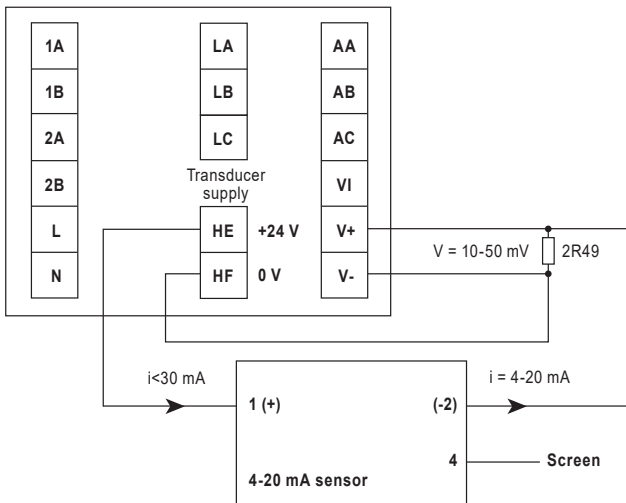

Wiring diagram for connecting the transmitter SX90

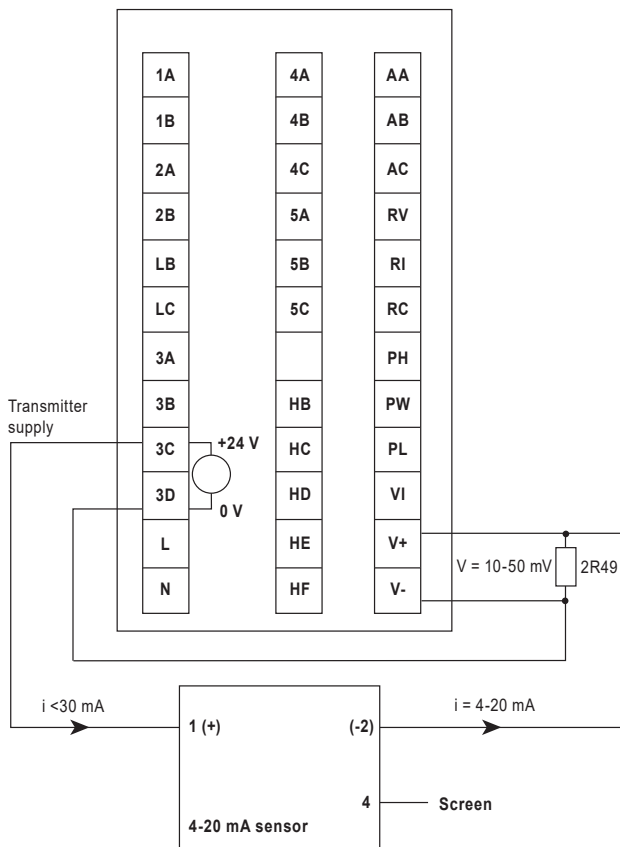

SX80 and SX90 Quickstart Guide

4. Commissioning



4.1 Operation

By default the following settings can be made in Operator Level 1

To select Auto, Manual or OFF mode

In the HOME display:

Press and hold the  and  buttons together for more than 1 second

Press the  button to select Manual (man), Off (Off) and Auto(Auto).
In Manual (or OFF) mode, MAN will be lit. When in Manual press the  or  buttons to decrease or increase output power.

Alarm indication

The red ALM beacon will flash. A scrolling text message will describe the source of the alarm. Any output attached to the alarm will operate (de-energise) by default.



To acknowledge the alarm:

Press the  and  (ACK) buttons together.

By default, alarms are configured as manual latching and can only be reset when the alarm conditions are no longer present.

To re-enter Quick Code configuration mode

If you need to re-enter the 'Quick Configuration' mode this can always be done by powering down the controller, holding down the  button, and powering up the controller again.

You must then enter a pass code using the  or  buttons. In a new controller the pass code defaults to 4. If an incorrect pass code is entered you must repeat the whole procedure.

To adjust the Set Point

(Target temperature/pressure)

In the HOME display:-

Press the  button to raise the Set Point.

Press the  button to lower the Set Point.







The new Set Point is entered when the button is released and is indicated by a brief flash of the display.

4.2 Operator Level 2

Parameters are available in deeper levels of access protected by security codes.

Level 2 Parameters are typically used when commissioning the controller.

To select Level 2:

1. From any display press and hold the  button until Lev1 is shown.
2. Release the  button and press the  or  buttons to choose Lev2 (Level 2).
3. Press the  or  buttons to enter the pass code. Default = 2.

4.3 Level 2 parameters

Press the  button to step through a list of parameters. After 5 seconds the parameter mnemonic is followed by a scrolling description.

Press the  or  buttons to adjust the value/range of the parameter.

Mnemonic	Scrolling Text	Range	
WRK.OP	WORKING OUTPUT	Active output value. Shown when the controller is in AUTO or OFF mode. Read only.	
WRK.SP	WORKING SETPOINT	Active setpoint value (SP1, SP2, SP3 or REM.SP). Shown when the controller is in MAN or OFF mode. Read only.	
UNITS	DISPLAY UNITS	°C, °F, °k, non, perc (%)	
SP.HI	SETPOINT HIGH	High and low setpoint limit applied to SP1, SP2, SP3 and Remote Setpoint REM.SP.	
SP.LO	SETPOINT LOW		
SP1/2/3	SETPOINT 1, 2 or 3	Setpoint 1, 2 or 3 adjust. Alterable between SP.HI and SP.LO.	
SP.RRT	SETPOINT RISING RATE LIMIT	Sets increasing rate of change of SP. Alterable: OFF to 3000 units/min	When set to a value, 'RUN' illuminates when the setpoint is changed.
SP.FRT	SETPOINT FALLING RATE LIMIT	Sets decreasing rate of change of SP. Alterable: OFF to 3000 units/min	

Mnemonic	Scrolling Text	Range
HOLD/B	HOLDBACK	SX09 only. Stops the setpoint ramp if deviation between SP and PV > the set value. Range OFF or 1 to 9999.
TM.CFG	TIMER CONFIGURATION	None = no timer configured SF.St = A soft start timer starts automatically on power up. It applies a power limit (SS.PWR) until the PV reaches a threshold value or the timer times out (DWELL). The threshold value = WKG.SP – SS.SP. It does not operate with boundless valve position.

Further parameters are shown if soft start is configured (See Note 1).

Mnemonic	Scrolling Text	Range
A1/2.xx	ALARM 1/2 SETPOINT (if configured)	xx = HI (high), LO (low), D.HI (deviation low), BND (deviation band). Alterable over the controller range.
MTR.T	MOTOR TRAVEL TIME	Set this to the time taken for the motor to travel from fully closed to fully open. 0.0 to 999.9 seconds
A.TUNE	AUTO-TUNE ENABLE	Automatically sets the control parameters to match the process characteristics. Set to On to start the process.
PB	PROPORTIONAL BAND	1 to 9999 display units Default: 20.
TI	INTEGRAL TIME	1 to 9999 seconds. OFF can be set if control type = PID. Default: 360.
TD	DERIVATIVE TIME	OFF, 1 to 9999 seconds. Default: 60 for PID.
MR	MANUAL RESET	Not for VP. Otherwise range -100.0 to 100.0%
R2G	RELATIVE COOL GAIN	Adjusts the cooling proportional band relative to the heating proportional band. Heat/cool only. Range 0.1 to 10.0. Default 1.0.
D.BAND	CHANNEL 2 DEADBAND	Sets a zone between heating and cooling outputs when neither output is on. Quick Code Function 2 = A only. Range OFF or 0.1 to 100.0% of the cooling proportional band.

These parameters are further described in the Engineering Manual.

Note 1: TM.RES, TIMER RESOLUTION; SS.PWR,SOFT START POWER LIMIT; SS.SP, SOFT START SETPOINT; DWELL, SET TIME DURATION; T.REM, TIME REMAINING.

5. Maintenance

This instrument has no user serviceable parts.

Contact your supplier for repair.

