

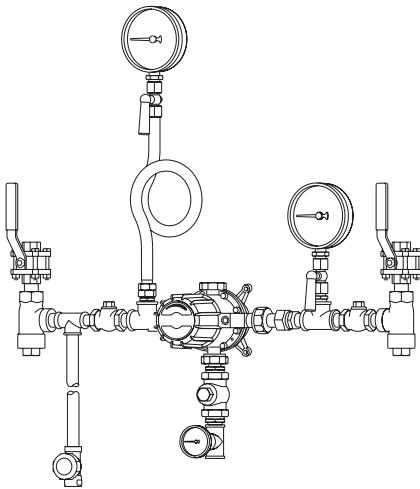

Steam/Water Mixing Stations (MkII valves - 2002 onwards)

Safety and Operation

Installation and Maintenance Instructions



1. General safety information
2. General product information
3. How to size
4. Installation
5. Maintenance
6. Spare parts
7. Fault finding

These instructions should be read by the Company Safety Officer

1. Safety information

Safe operation of the unit can only be guaranteed if it is properly installed, commissioned and maintained by a qualified person (see Section 11 of the attached Supplementary Safety Information) in compliance with the operating instructions. General installation and safety instructions for pipeline and plant construction, as well as the proper use of tools and safety equipment must also be complied with.

1.1 Pressure

Before attempting any maintenance of any component of the steam/water mixing station consider what is or may have been in the pipeline. Ensure that any pressure is isolated and safely vented to atmospheric pressure before attempting to maintain any component, e.g. mixing valve, hose etc. This is easily achieved by fitting Spirax Sarco depressurisation valves type DV (see separate literature for details). Discharge contents of the hose and station by pulling the gun trigger and eliminate pressure until water flow stops. Do not assume that the system is depressurised even when the pressure gauge indicates zero.

1.2 Temperature

Allow time for temperature to normalise after isolation to avoid the danger of burns. For personal protection wear protective clothing, especially heavy duty gloves and safety glasses.

PTFE:

If parts made from PTFE have been subjected to a temperature approaching 260 °C (500 °F) or higher, they will give off toxic fumes, which if inhaled are likely to cause temporary discomfort. It is essential for a no smoking rule to be enforced in all areas where PTFE is stored, handled, or processed as persons inhaling the fumes from burning tobacco contaminated with PTFE particles can develop 'polymer fume fever'.

Viton:

If parts made from Viton have been subjected to a temperature approaching 315 °C (599 °F) or higher, it may have decomposed and formed hydrofluoric acid. Avoid skin contact and inhalation of any fumes as the acid will cause deep skin burns and damage the respiratory system.

1.3 Disposal

The product is recyclable. No ecological hazard is anticipated with the disposal of this product providing due care is taken, except;

PTFE:

- Can only be disposed of by approved methods, not incineration.
- Keep PTFE waste in a separate container, do not mix it with other rubbish, and consign it to a landfill site.

Viton:

- Can be land filled, when in compliance with National and Local regulations.
- Can be incinerated, but a scrubber must be used to remove Hydrogen Fluoride, which is evolved from the product and with the compliance to National and Local regulations.
- Is insoluble in aquatic media.

Please visit the Spirax Sarco product compliance web pages

<https://www.spiraxsarco.com/product-compliance>

for up to date information on any substances of concern that may be contained within this product. Where no additional information is provided on the Spirax Sarco product compliance web page, this product may be safely recycled and/or disposed providing due care is taken. Always check your local recycling and disposal regulations.

1.4 Warning

This product must only be installed and commissioned by qualified personnel (see Section 1.5). The hosedown station includes a safety device called the TCO1. This temperature cut-out valve activates at a temperature of 95 °C (203 °F) to limit the discharge of steam in the event of a system fault. This assumes 20 m (65.6 ft) hose installed - shorter length hoses may result in a brief discharge of steam following activation of the TCO1.

The mixing valve must always be operated with an element in the TCO1 to prevent steam reaching the hose. In the event that the hosedown station is used without an element in the TCO1 then Spirax Sarco will not accept any consequential liability for the operation of the hosedown station in this manner.

Always operate the hosedown station as instructed on the warning notice sent out with the equipment; particularly regarding protective clothing. The WARNING NOTICE must always be displayed by the mixing valve.

1.5 Qualified personnel

For the purposes of these operating instructions qualified personnel are persons who are experienced in the installation, commissioning and operation of this product and who are suitably qualified to perform their duties, e.g.:

- Have received training or instruction in the maintenance and use of appropriate safety equipment according to current safety standards.
- Have received training in first-aid.

1.6 Safety test procedure

A safety check undertaken by qualified personnel must be carried out each time the unit is used.

The safety test and subsequent maintenance procedure ensures that live steam cannot be discharged from the gun, which would happen in the event of e.g. a seized piston.

Due to the possible presence of steam, please ensure due care and attention are observed when undertaking this task. Wear protective clothing, especially heavy duty gloves and safety glasses.

With the cold water inlet valve shut and the steam inlet valve open, carefully operate the gun. Before pulling the trigger, hold the gun firmly in both hands and adopt a body position which will prevent loss of balance due to recoil from the hose gun.

There should be no flow observed at the gun. If steam flow is detected during the test, or the TCO1 activates, the hosedown station, it must be taken out of service immediately. Please refer to Section 5, 'Maintenance'.

The above test must be repeated after maintenance to the steam/water mixing valve.

1.7 Danger of injury

Should you intend to use Spirax Sarco products for new or not tested fluids or for applications not described in Spirax Sarco product information please contact the Spirax Sarco applications department or our local sales engineer for written advice.

All hose and gun assemblies are to be tested for operational safety from time to time. This should include a daily visual inspection. If damage occurs (this also applies to the hose cover) the hose and gun assemblies must be renewed, for safe working.

The same constant vigilance should also be applied to the valve and its fittings and the hosedown gun.

The mixing valve must always operate with an element in the TCO1 to prevent steam reaching the hose. In the event that the hosedown station is used without an element in the TCO1 then Spirax Sarco will not accept any consequential liability for the operation of the hosedown station in this manner.

2. General product information

2.1 General information

Note: These Installation and Maintenance Instructions are for MkII systems/ valves supplied from the year 2002 onwards. For earlier valves, see separate Installation and Maintenance Instructions IM-P157-03.

Design

The Spirax Sarco steam/water mixing station is designed to provide hot water economically by blending steam and cold water quickly to the required user temperature. This temperature can be altered by turning the temperature adjustment knob. As the valve is not thermostatically controlled, in order to maintain a fixed hot water temperature the cold water pressure and flowrate must be constant. The temperature cut-out valve TCO1 will limit any steam supply from the mixing valve in the event of a system fault.

Operation

The mixing valve employs a piston to lift and open the steam valve. The piston is lifted by the cold water supply. If the cold water supply stops the piston will fall, closing the steam valve.

Maintenance

This operation can only occur if the piston is free to move. Scale will seize the piston and the valve must be maintained and cleaned regularly to prevent scale build-up and ensure safe valve operation. This is especially important in hard water areas. The pressure gauges supplied with the mixing station are installed in the steam and cold water supply lines to aid fault finding.

Ancillaries

Each steam/water mixing station is supplied with isolation valves, check valves, union joints, steam trap, strainers (with 100 mesh stainless steel screens), pressure gauges, syphon and cocks, thermometer and temperature cut-out valve (see Figure 1).

Note: For further information see the following Technical Information Sheets:

TI-P157-05	Hosedown gun, hose and hose rack
TI-P157-06	Steam/water mixing stations
TI-P157-08	Steam/water mixing valve
TI-P157-18	TCO1 temperature cut-out valve

These sheets give full details of:- Materials, sizes and pipe connections, dimensions, weights, operating ranges and capacities.

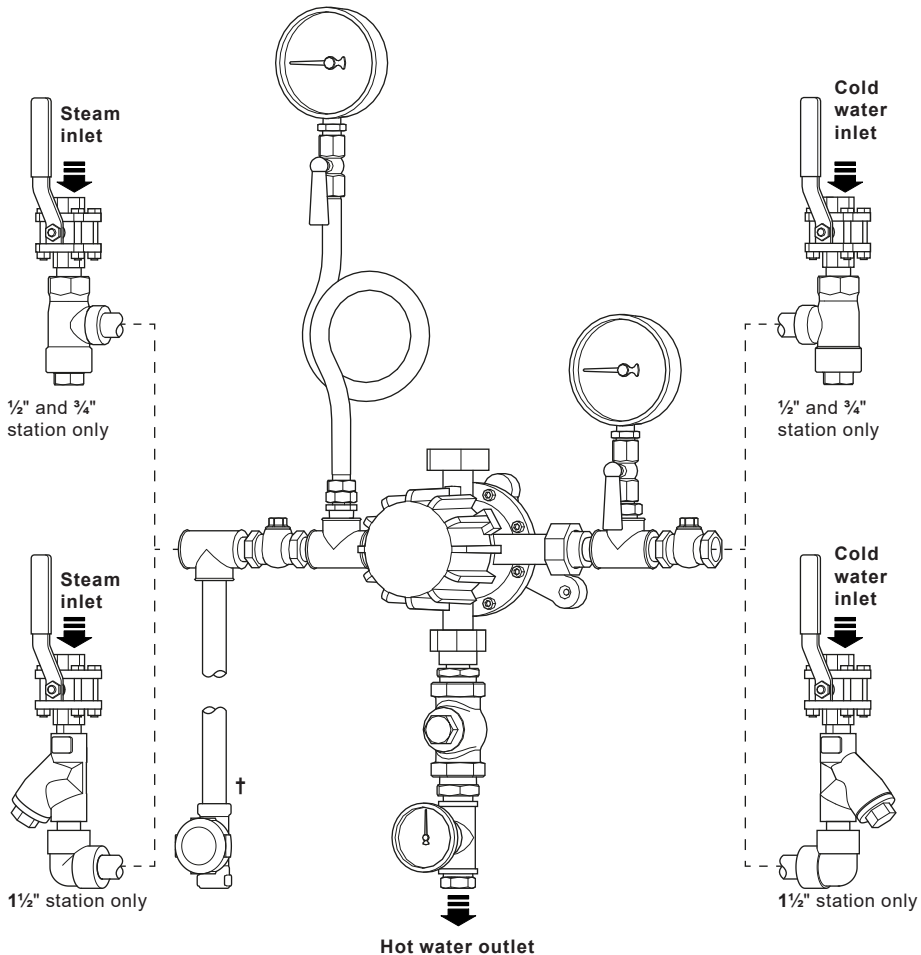

† Inter connecting pipe is not supplied with the mixing valve station. This pipe should be at least 0.5 m (19.3") long to prevent condensate backing up into the steam line.

Fig. 1 3/4" and 1 1/2" assembly shown

2.2 Technical data

2.2.1 Minimum flow (to open the steam valve) and spring selection chart (see Table 1)

A restricted outlet can cause back pressure, reducing the water flow through the mixing valve which may prevent a sufficient amount of steam entering the mixing chamber.

The minimum flow for each size of mixing valve is shown in Table 1 below.

Note: when a valve supplies water against a back pressure a minimum pressure drop of approximately 1 bar (14.5 psi) is required across the mixing valve to allow the steam valve to lift off its seat.

Table 1

Size	Spring value	Spring colour code *	Steam pressure			Min. flow to open steam valve		Spring notch marking
			psi	bar	kg/cm ²	g/min	l/min	
1/2"	High	Y	100 - 150	7.00 - 10.3	7.14 - 10.51	1.0	4.5	Three
	Medium	G	50 - 100	3.50 - 7.0	3.57 - 7.14	0.6	2.7	Two
	Low	Bl	5 - 50	0.35 - 3.5	0.36 - 3.52	0.5	2.3	One
3/4"	High	R	100 - 150	7.00 - 10.3	7.14 - 10.55	1.8	8.2	Three
	Medium	B	50 - 100	3.50 - 7.0	3.57 - 7.14	1.5	6.8	Two
	Low	W	5 - 50	0.35 - 3.5	0.36 - 3.52	6.0	6.8	One
1"	High	R	100 - 150	7.00 - 10.3	7.14 - 10.51	8.0	36.3	Three
	Medium	B	50 - 100	3.50 - 7.0	3.57 - 7.14	7.0	31.8	Two
	Low	W	5 - 50	0.35 - 3.5	0.36 - 3.52	6.0	27.2	One
1 1/2"	High	R	100 - 150	7.00 - 10.3	7.14 - 10.51	12.0	54.4	Three
	Medium	B	50 - 100	3.50 - 7.0	3.57 - 7.14	12.0	54.4	Two
	Low	W	5 - 50	0.35 - 3.5	0.36 - 3.57	12.0	54.4	One

* Y = Yellow
 G = Green
 Bl = Black
 R = Red
 B = Blue
 W = White

2.3 Options for 1/2" and 3/4" steam/water mixing stations

2.3.1 Hose

Temperature range	Saturated steam +165 °C (329 °F)
	Continual hot water operation + 100 °C (212 °F)
Safety factor	10:1 for steam, 3.15:1 at 18 bar (261 psi) working pressure
Lining	EPDM rubber, white, smooth, compounded using FDA approved ingredients
Reinforcement	High strength synthetic textile
Cover	EPDM rubber, blue, weather, ozone and abrasion resistant
Identification	White band ARCO 39174 - FDA, Food/steam 6 bar 165 °C

2.3.2 Hosedown gun

There are two sizes of hosedown gun; the 1/2" gun used with the 1/2" hose and 1/2" steam/water mixing station. Similarly the 3/4" gun used with the 3/4" hose and 3/4" steam/water mixing station. **Hosedown guns and hoses should never be used with 1" and 1 1/2" steam/water mixing stations** (see Figure 2).

Temperature	100 °C	(212 °F)
Maximum pressure	10 bar g	(145 psi g)
Capacity	With wide spray	42 l/min at 5 bar (9.25 gal/min at 72.5 psi)
	With jet spray	25 l/min at 5 bar (5.50 gal/min at 72.5 psi)

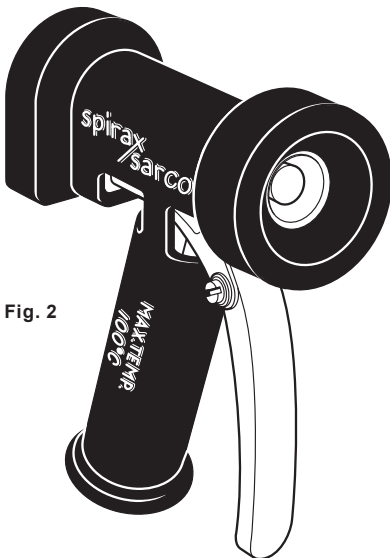
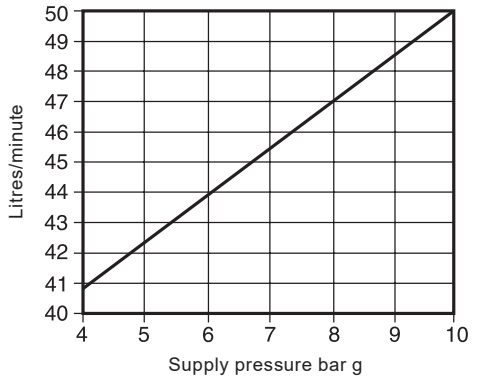

Fig. 2

Capacities (approximate)



3. How to size

(Please note: Only SI metric figures have been used in this section)

The graphs indicate the maximum flow of hot water at various temperatures for a given steam supply pressure. The bold line shows the maximum cold water flow for a given water supply pressure. When sizing the valve, ascertain the hot water temperature and quantity required, and the water and steam pressure available. The cold water and steam supply pressure should be nominally equal for satisfactory operation.

Plot the cold water supply pressure and read off from the bold line the maximum flow of cold water. Plot the steam supply pressure against the running temperature required and read off the maximum flow of heated water. For sizing purposes always select the lowest of the two values because depending on the supply pressures, there can be an imbalance in the amount of either water or steam heat available. The effect of selecting different supply pressures or different sizes of valve can easily be compared.

In the example shown below the lowest flowrate plotted is 32 l/min. If the required hot water flowrate was 30 l/min. then the 1/2" mixing valve would be suitable. If the required hot water flowrate was 37 l/min we would need to select a 3/4" mixing valve (although the 1/2" mixing valve can pass 40 l/min of cold water), since the lowest flowrate plotted must exceed the required hot water flowrate.

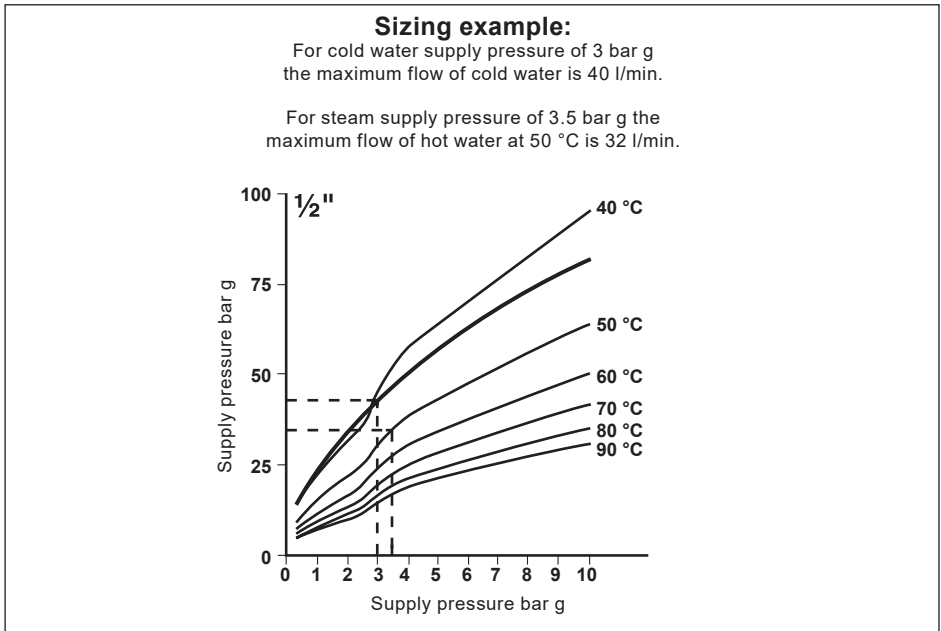

Steam/water mixing valve capacities

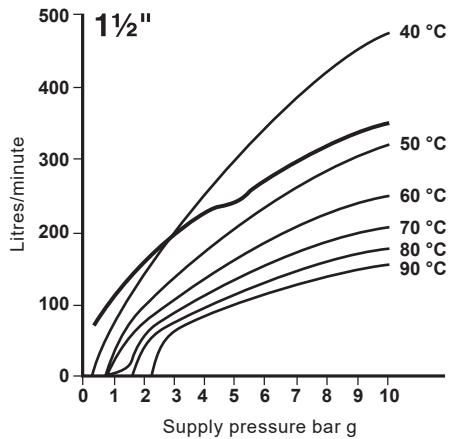
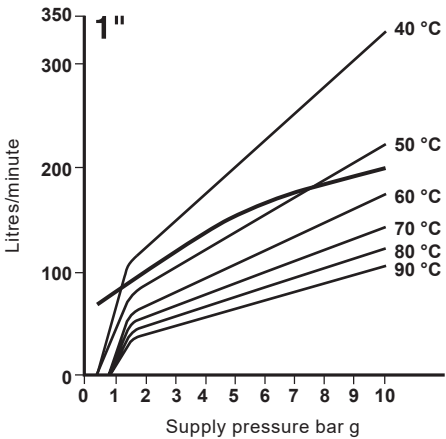
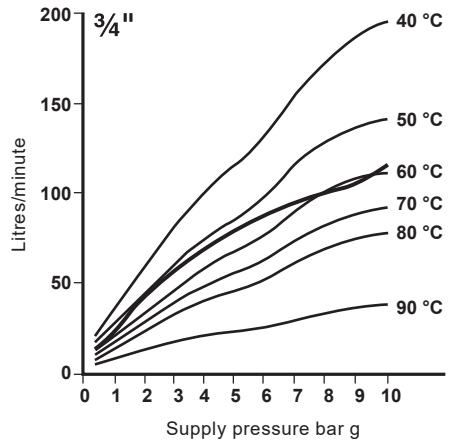
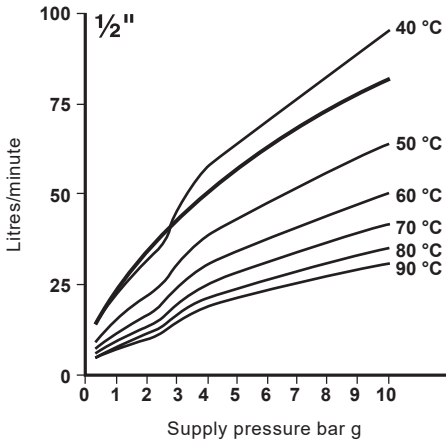

4. Installation

Note: Before actioning any installation observe the 'Safety information' in Section 1.

4.1 General

The steam/water mixing valve should be carefully unpacked and the contents checked against the packing list. (See Figure 4). The steam/water mixing valve has two hot water outlets which means that hot water can always flow downwards from the valve regardless of the orientation of the steam and cold water supply lines. Plug the hot water outlet that is not being used.

4.2 Installation without hoses

4.2.1 Selection and installation of high pressure fixed loading spring

The steam/water mixing valve is supplied with the medium pressure fixed loading spring fitted for steam pressures between 3.5 to 7.0 bar g (50 to 100 psi g). For steam pressures between 7.0 to 10.3 bar g (100 to 150 psi g) the high pressure fixed loading spring must be fitted and the relevant spring name-plate attached to the valve body. The following instructions, in conjunction with Figure 3, must be followed when a high pressure fixed loading spring needs to be fitted:-

IMPORTANT NOTE:

A high pressure fixed loading spring can only be installed if the following site conditions prevail:

- **If the valve is running to an open outlet (i.e. no restriction on the downstream side of the valve), the steam to water pressure ratio, must not exceed, 3:1. It is advisable that the cold water pressure does not exceed the steam pressure as this will inhibit the ability of the valve to produce hot water.**
 - **If there is a restriction on the outlet (e.g. hosedown gun, pipework or hose, control or isolation valve, etc.) the steam pressure and water pressure must be nominally equal.**
1. Turn the ball valves to isolate steam and cold water supplies. Remove any residual pressure from the mixing valve station by opening the outlet from the valve, e.g. hose gun. **Do not assume that the system is depressurised even when a pressure gauge indicates zero.**
 2. Turn the temperature adjustment knob (12), clockwise to the fully open (hot) position.
 3. Remove the temperature adjustment knob (12) by loosening the temperature adjustment knob retaining screw (10).
 4. Remove the upper head (1) (R/H thread) using a 30 mm A/F spanner.
 5. Remove the medium pressure fixed loading spring (11) and replace with the high pressure fixed loading spring.
 6. Before reassembly ensure that the gasket faces of upper body (3) and upper head (1) are clean ready to receive the new gasket. Replace the top gasket (15).
 7. Before reassembling the top cap ensure that the steam valve spring (2) is upright in the spindle recess. Screw the upper head (1) into the upper body (3) and tighten to a torque setting of 120 to 130 N m (88 - 95 lbf ft) for ½" and ¾" valves. A torque setting of 180 to 200 N m (132 - 147 lbf ft) for 1" and 1½" valves.
 8. Remove the medium steam pressure range label and replace with the high pressure label.

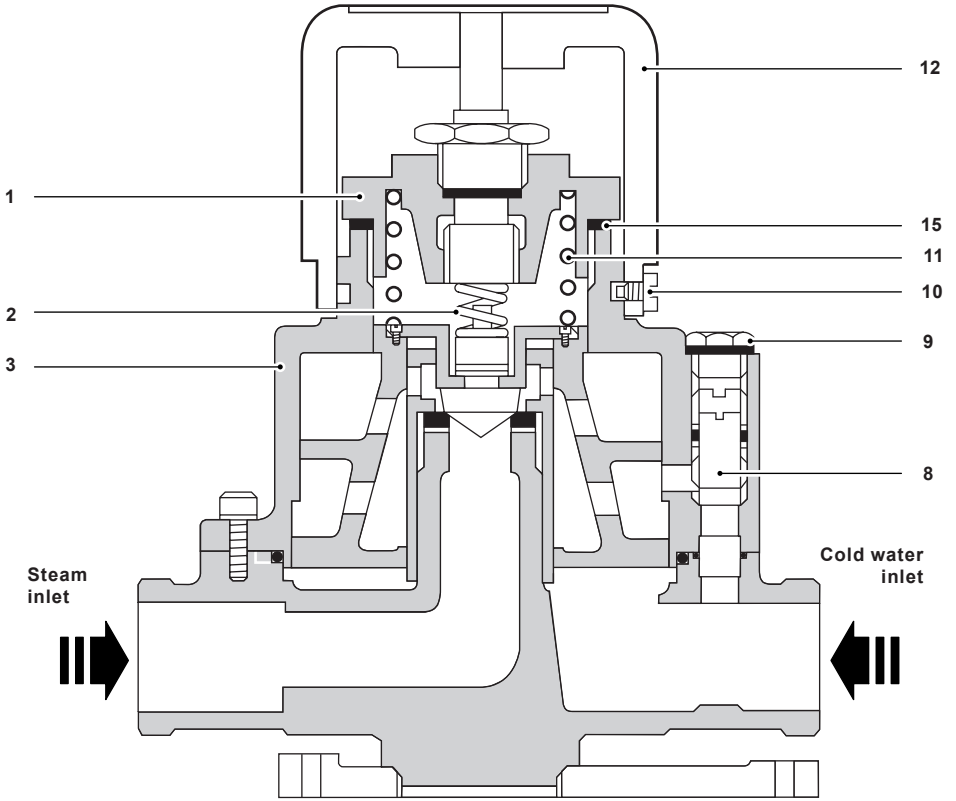

Fig. 3

Commissioning the valve to set temperature:

9. Remove the temperature adjustment knob retaining screw (10) and turn the temperature adjustment knob (12) fully clockwise.
10. Remove the adjustment knob and replace making sure that the retaining screw location is just anticlockwise of one of the two location stops.
11. Replace the retaining screw (10) and check that the temperature adjustment knob has at least 180° of movement. If not, repeat Steps 9 and 10 positioning the retaining screw just anticlockwise of the other location stop.
12. Remove the bypass screw (9).
13. Open the bypass valve fully anticlockwise.
14. Turn the adjustment knob fully anticlockwise (coldest setting).
15. Turn on the water and steam, then hold the gun open (see 'Start-up', Section 4.4.1). Check the hot water temperature. Turn the bypass valve (8) clockwise until either the temperature is just below that required or the flow has been reduced significantly.
Note: It is normal for the flowrate to decrease through the use of the bypass valve. If the flow is less than that required please refer to 'Fault finding', Section 7.
16. Turn the adjustment knob clockwise to increase the hot water temperature. There may be a short delay during temperature adjustment.
17. If the desired temperature is not achieved, turn the adjustment knob fully anticlockwise and repeat Steps 15 and 16.
Note: The maximum hot water temperature is 90 °C (194 °F).
18. Close the gun.
19. Replace the bypass screw (9).

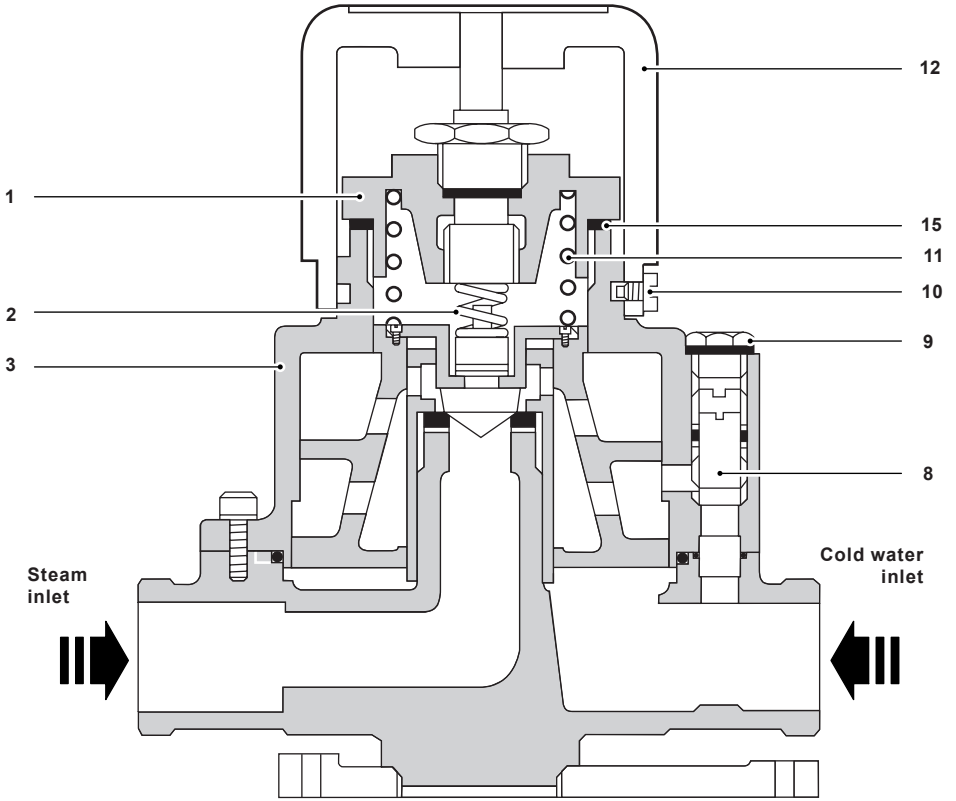

Fig. 3

4.2.2 Installation

Remove the wall bracket from the mixing valve. Screw the wall bracket to the wall in the final position, using a suitable fitting. Thread the valve back onto the wall bracket.

When replacing a steam/water mixing valve in a mixing valve station the spool pieces supplied must be installed between the pressure gauge 'T' piece and the mixing valve union in the steam and cold water supply lines. This will take account of the smaller overall dimension of the replacement valve.

The pipework should be assembled according to Figure 4 using a suitable thread sealing medium. The temperature cut-out valve (N) is only provided on ½" and ¾" sizes.

NOTE: The minimum supply pressures for the steam and water must be such, that a pressure drop of at least 1 bar (14.5 psi) is maintained across the valve. The maximum pressure for each supply is 10 bar (145 psi). Steam and water pressures are required to be nominally equal. (Please see Section 7, 'Fault finding' for details).

To connect the thermometer, screw the reducing bush (M) into the top of the 'T' piece (K); push the thermometer (E) into the pocket (L) and lock in place with the grub screw; tighten the pocket into the reducing bush.

To connect the hot water supply pipework to the hot water outlet of the steam/water mixing valve first screw the thermometer 'T' piece and TCO1 to the hot water pipe. This arrangement should then be attached to the steam/water mixing valve using the hot water outlet union fitted to the mixing valve. Care should be taken to ensure that the dial face of the thermometer and the hexagon cap of the TCO1 are in line with the temperature adjustment knob (see Figure 4).

IMPORTANT NOTE:

The installation should be completed so as to comply with any Local Water Board Regulations, with regard to direct use of mains water supply. A break tank may be required to provide an air gap for each valve.

If a booster pump is being used to supply an adequate constant cold water supply pressure, then pressure switches must not be used, since this can affect the operation of the steam/water mixing valve station. Installation of a balanced line arrangement should be considered; (a typical layout is shown in Figure 12).

4.3 Installation for hosedown purposes

The steam/water mixing valve station should be carefully unpacked and the contents checked against the packing list (see the Table on page 18 in conjunction with Figure 5).

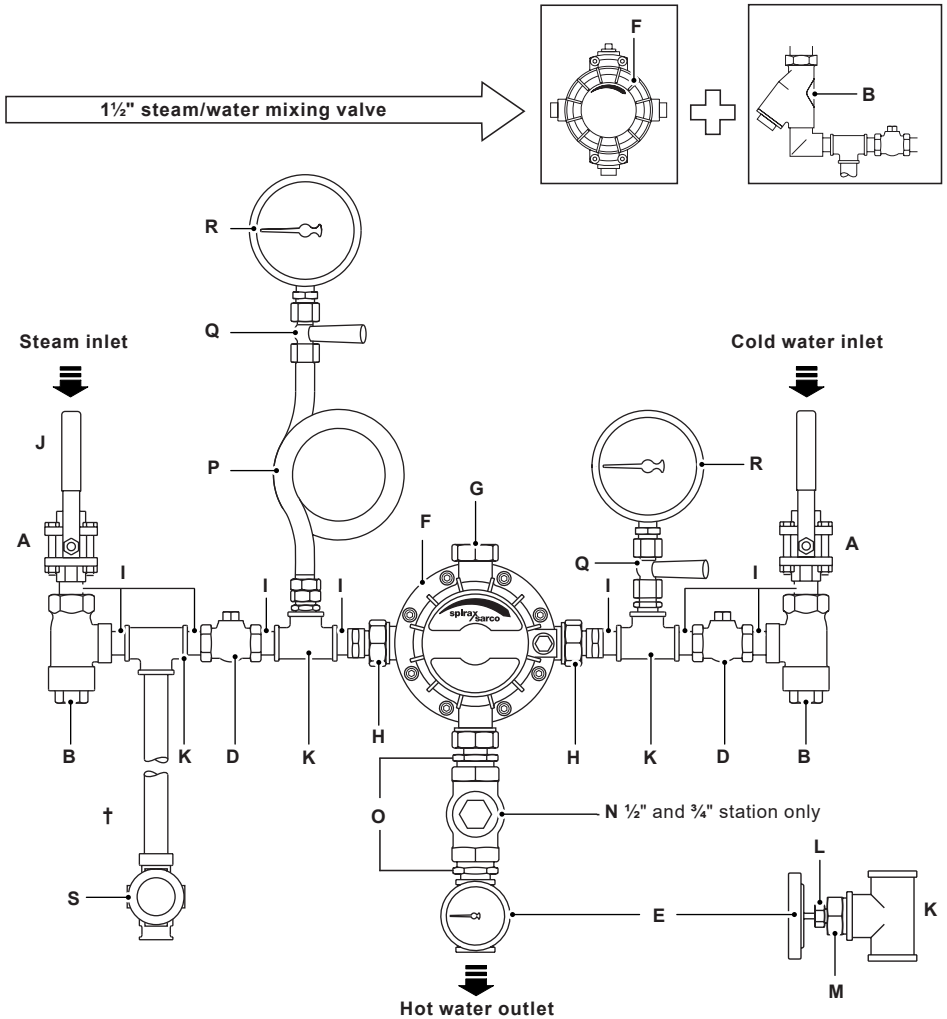

† Inter connecting pipe is not supplied with the mixing valve station. This pipe should be at least 0.5 m (19.3") long to prevent condensate backing up into the steam line.

Fig. 4

Steam/water mixing station packing list:

A Ball valves	H M/F unions	N Temperature cut-out valve (1/2" and 3/4" station only)
B Strainers	I Nipples	O Reducing nipples
D Check valves	J Red handle cover	P Ring syphon
E Thermometer	K 'T' piece	Q Cock
F Steam/water mixing valve	L Thermometer pocket	R Pressure gauge
G Plug	M Reducing bush	S Steam trap

Description		Used on			
		1/2"	3/4"	1	1 1/2"
Elbow	1 1/2"			2	2
Union	1 1/2"				2
Barrel nipple	3/8"			1	
	1/2"	9			
	3/4"		9		
	1"			10	
	1 1/2"				10
Reducing nipple	1/2" x 3/8"	1			
	3/4" x 3/8"		1		1
	1" x 3/4"	1	2		
	1" x 1/2"	1			
Equal 'T'	1/2"	3			
	3/4"	1	4		
	1"			3	
	1 1/2"				4
Reducing 'T'	1" x 3/4"			1	
Reducing bush	3/4" x 1/2"	1	1		1
	1" x 1/2"			1	
	1 1/2" x 3/4"				4
	1/2" x 3/8"	1			
	3/4" x 3/8"		1		1
	1" x 3/8"			2	

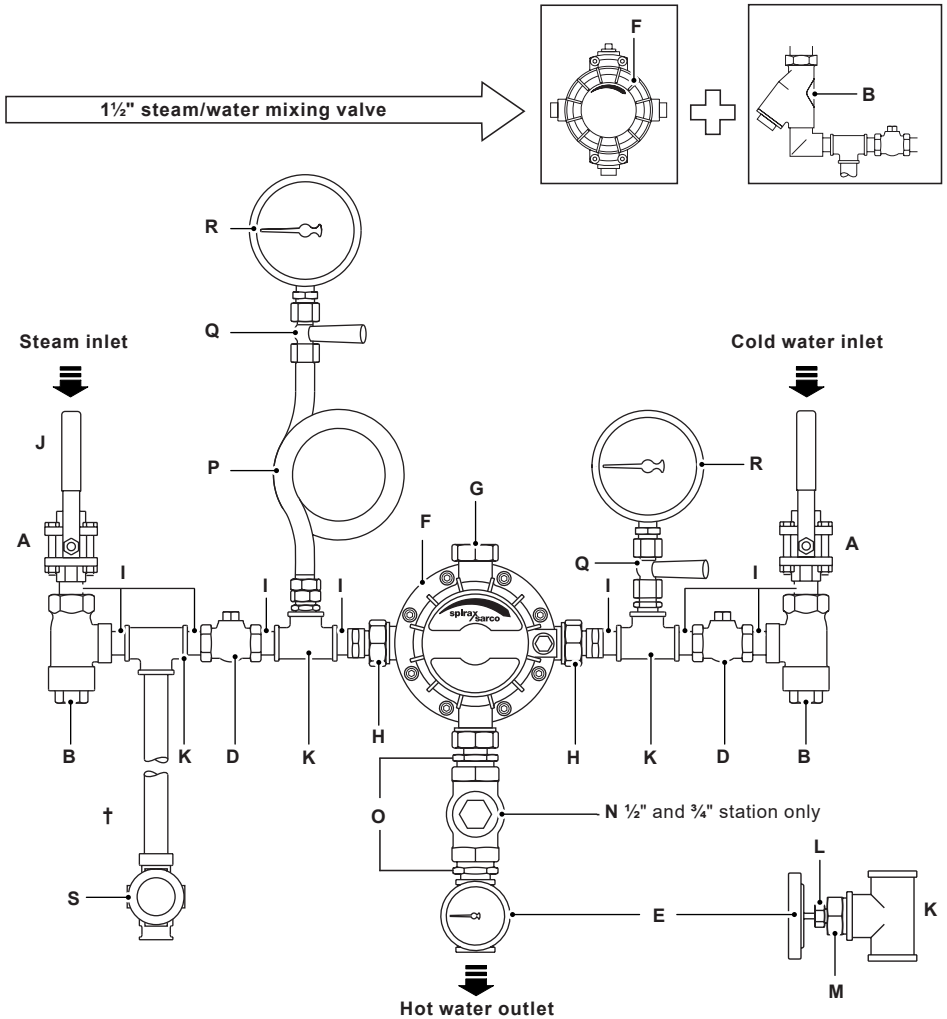

† Inter connecting pipe is not supplied with the mixing valve station. This pipe should be at least 0.5 m (19.3") long to prevent condensate backing up into the steam line.

Fig. 5 Packing list

NOTE: For satisfactory hosedown purposes steam and water supplies should have a minimum pressure of 3 bar g (43.5 psi g) and a maximum pressure of 10 bar g (145 psi g) and are required to be nominally equal. (Please see Section 7 , 'Fault finding', for details). The minimum pressure provides a reasonable spray velocity and flowrate at the gun (see Figure 7).

When replacing a steam/water mixing valve in a mixing valve station the spool pieces supplied must be installed between the pressure gauge 'T' piece and the mixing valve union in the steam and cold water supply lines. This will take account of the smaller overall dimension of the replacement valve.

Connect the pipework fittings according to Figure 4 using a suitable thread sealing medium. The TCO1 is installed between the hot water outlet of the mixing valve and the equal 'T' that houses the thermometer. The TCO1 is connected to the equal 'T' using a 1" x ¾" reducing nipple. The other end is connected to the valve via a reducing nipple and the male/female union joint on the mixing valve. Care should be taken to ensure that the hexagon cap is in line with the dial face of the thermometer when the arrangement is tightened into the valve. To attach the hose to the thermometer 'T' piece first screw the male/male equal nipple into the 'T' piece. The hose is then connected to the male/male equal nipple via the female union on the hose (see Figure 6).

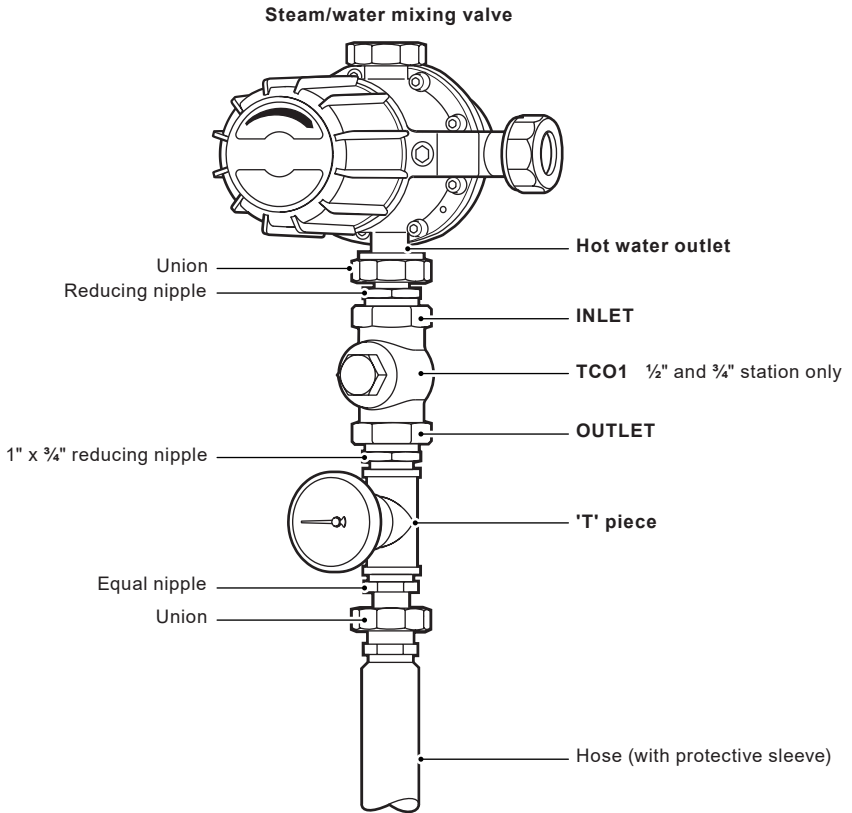
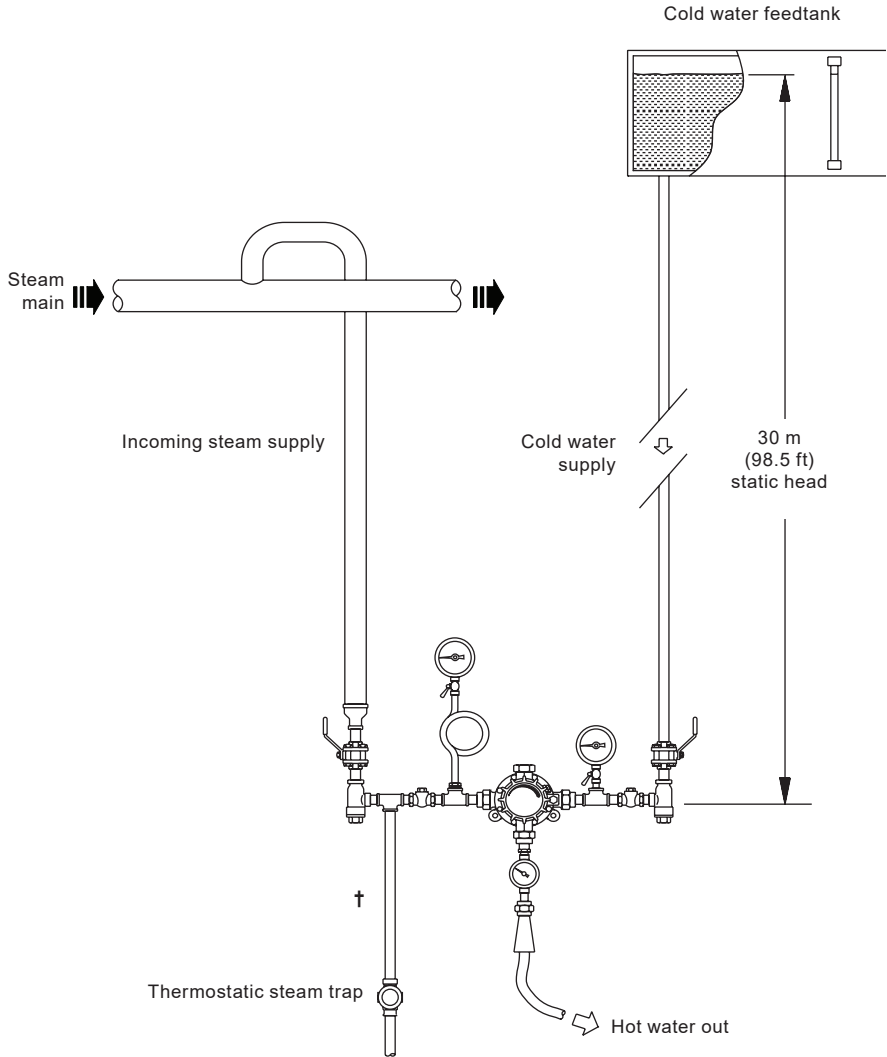

Fig. 6



† Inter connecting pipe is not supplied with the mixing valve station. This pipe should be at least 0.5 m (19.3") long to prevent condensate backing up into the steam line.

Fig. 7
Typical arrangement showing ½" and ¾" hoses down stations using static head to supply minimum cold water pressure of 3 bar g (43.5 psi g)

IMPORTANT NOTE:

The TCO1 must be installed with the end marked 'INLET' connected to the mixing valve and the end marked 'OUTLET' to the 'T' piece (K), see Figure 8. (These markings are stamped onto the hexagon end connections). The TCO1 is a safety device, if it is installed in reverse it will never be able to operate.

To connect the thermometer (E), (see Figure 8), screw the reducing bush (M) into the top of the 'T' piece (K); push the thermometer (E) into the pocket (L) and lock in place with the grub screw; tighten the pocket (L) into the reducing bush (M). The hose should be connected to the outlet of the 'T' piece (K) using the union on the hose. The hose may then be coiled onto the hose rack (if used). If using a self-retracting hose reel the hose will already be coiled and attached to the thermometer 'T' piece (K) using the hose union on its 2 m (6.5 ft) long connection hose (supplied with the self-retracting hose reel).

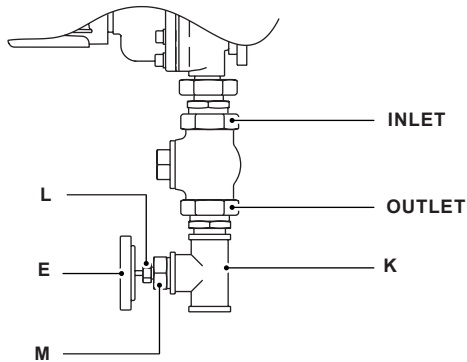
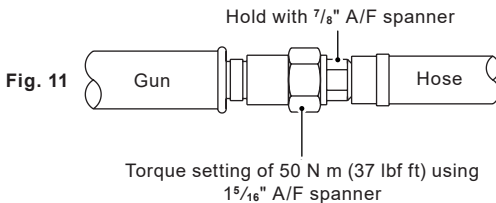
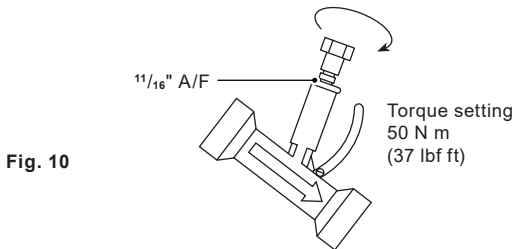
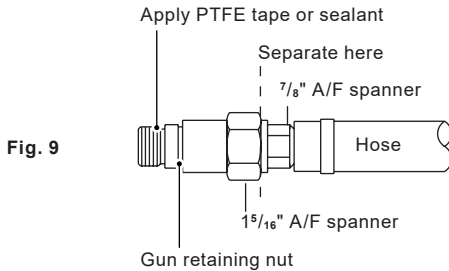

Fig. 8

The heavy duty gun is fixed to the hose using the swivel coupling (see Figures 9, 10 and 11)

The swivel coupling is connected to the hose as a complete item. It must be separated into two pieces so that the gun retaining can be correctly torqued into the gun.

- Fig. 9** Unscrew the retaining nut from the hose tail using $1\frac{5}{16}$ " A/F and $\frac{7}{8}$ " A/F spanners. Apply PTFE or thread sealant to the male thread of the retaining nut.
- Fig. 10** Unscrew the gun from the retaining nut using an $1\frac{1}{16}$ " A/F spanner on the spanner flats of the retaining nut. Tighten to 50 N m (37 lbf ft). On older $\frac{3}{4}$ " units insert a 12 mm A/F hex. allen socket into the gun handle to a torque of 50 N m (37 lbf ft).
- Fig. 11** Connect the gun to the hose by reassembling the two halves. Tighten to a torque setting of 50 N m (37 lbf ft).



The steam inlet should be drained of condensate (i.e. steam trap to drain vertical pipework, see Figure 12 for an example).

Supply pipework should be sized according to standard practice. The steam inlet pipework would be sized on the steam flowrate (from the steam consumption chart, TI-P157-06) at the supply pressure and steam velocity of between 15 to 25 m/s. Cold water pipework should take into account, pressure, pipe length and acceptable pressure drop.

The installation should be completed so as to comply with any Local Water Board Regulations, with regard to direct use of mains water supply. A break tank may be required to provide an air gap for each valve.

If a booster pump is being used to supply an adequate constant cold water supply pressure, then pressure switches must not be used, since this can affect the operation of the steam/water mixing valve station. Installation of a balance line arrangement should be considered; (a typical layout is shown in Figure 12).

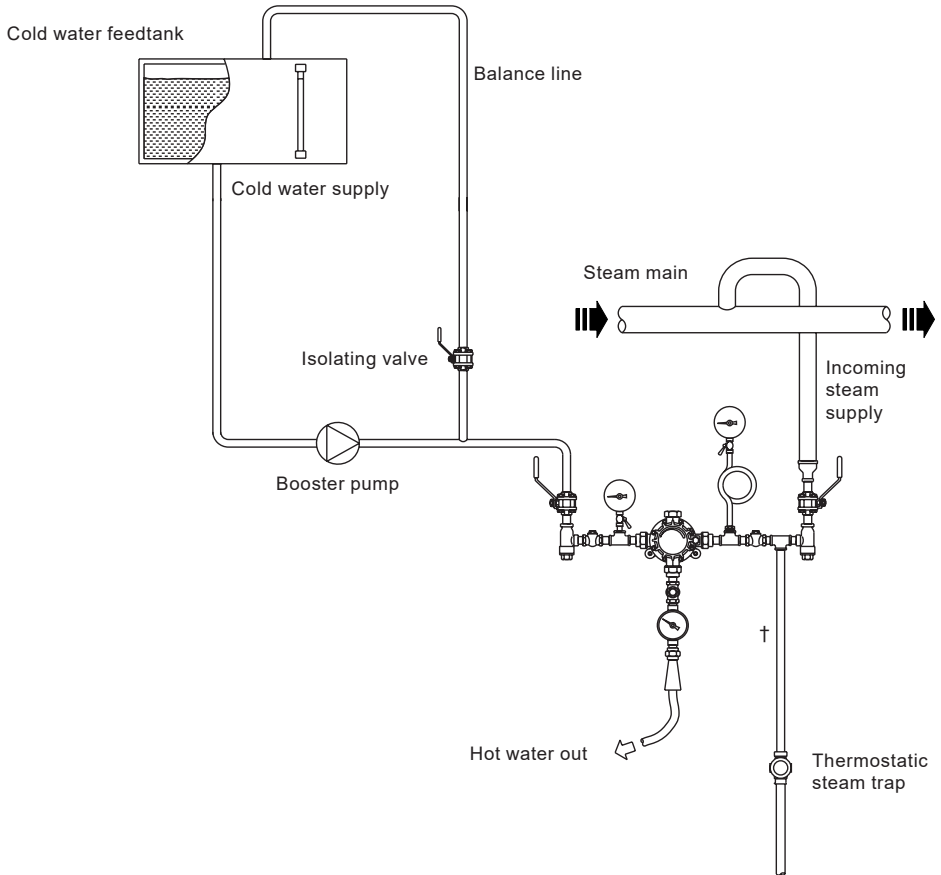

† Interconnecting pipe is not supplied with the mixing valve station. This pipe should be at least 0.5 m (19.3") long to prevent condensate backing up into the steam line.

Fig. 12 Typical arrangement for pumped cold water supply for ½" and ¾" hosesown stations

4.4 Start-up procedures

Cold water and steam supply pressures should have been determined prior to selecting the valve size. If the valve is running to an open outlet; i.e. no restriction on the downstream side of the valve, the steam to water pressure ratio, must not exceed, 3:1. It is advisable for the cold water pressure not to exceed the steam pressure as this may inhibit the ability of the valve to produce hot water. If there is a restriction on the outlet; e.g. hosedown gun, pipework or hose, control or isolation valve, etc. the steam pressure and water pressure must be nominally equal.

4.4.1 Start-up

Follow the 'Safety test procedure' on page 4. If the valve passes this test, open the cold water inlet isolation valve. **Do not point the gun at your body or anyone else, and hold with protective gloves.** Before pulling the trigger hold the gun firmly in both hands and adopt a body position that will prevent loss of balance due to recoil from the hosedown gun.

After use shut off the supply isolation valves. Discharge the contents and vent pressure from within the hose and steam/water mixing station by pulling the trigger until water flow stops.

4.4.2 Setting temperature

Once correctly installed the temperature is adjusted as follows (refer to Figure 14):

- a. Remove the temperature adjustment knob retaining screw (10) and turn the temperature adjustment knob (12) fully clockwise.
- b. Remove the adjustment knob and replace making sure that the retaining screw location is just anticlockwise of one of the two location stops.
- c. Replace the retaining screw (10) and check that the temperature adjustment knob has at least 180° of movement. If not, repeat Steps (a) and (b) positioning the retaining screw just anticlockwise of the other location stop.
- d. Remove the bypass screw (9).
- e. Open the bypass valve fully anticlockwise.
- f. Turn the adjustment knob fully anticlockwise (coldest setting).
- g. Turn on the water and steam, then hold the gun open as per Section 4.4.1. Check the hot water temperature. Turn the bypass valve (8) clockwise until either the temperature is just below that required or the flow has been reduced significantly.
Note: It is normal for the flowrate to decrease through the use of the bypass valve. If the flow is less than that required please refer to 'Fault finding', Section 7.
- h. Turn the adjustment knob clockwise to increase the hot water temperature.
- i. If the desired temperature is not achieved, turn the adjustment knob fully anticlockwise and repeat Steps (g) and (h).
Note: The maximum hot water temperature is 90 °C (194 °F).
- j. Close the gun.
- k. Replace the bypass screw (9).

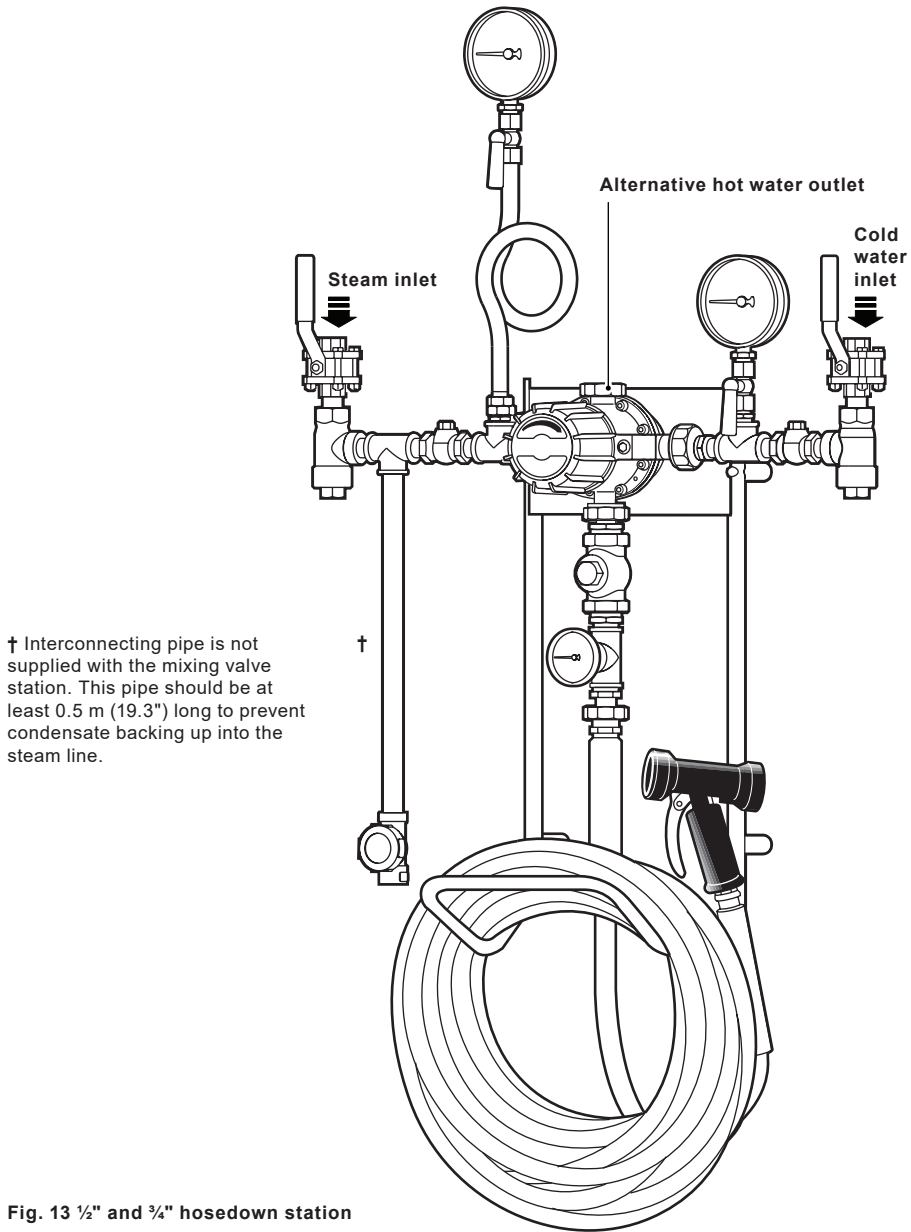

Fig. 13 ½" and ¾" hosedown station

4.5 Parts list

1	Upper head
2	Steam valve spring
3	Upper body
4	Piston
5	Lower body
6	Steam valve plug
7	Steam valve seat
8	Bypass valve
9	Bypass screw
10	Temperature adjustment knob retaining screw
11	Fixed loading spring
12	Temperature adjustment knob
13	Body 'O' ring
14	'O' ring packing washer
15	Top gasket
16	Bypass valve washer
17	Wall bracket
18	Cap screw
19	Washer
20	Bypass valve 'O' ring
21	Spigoted spring guide (1" and 1½" only)

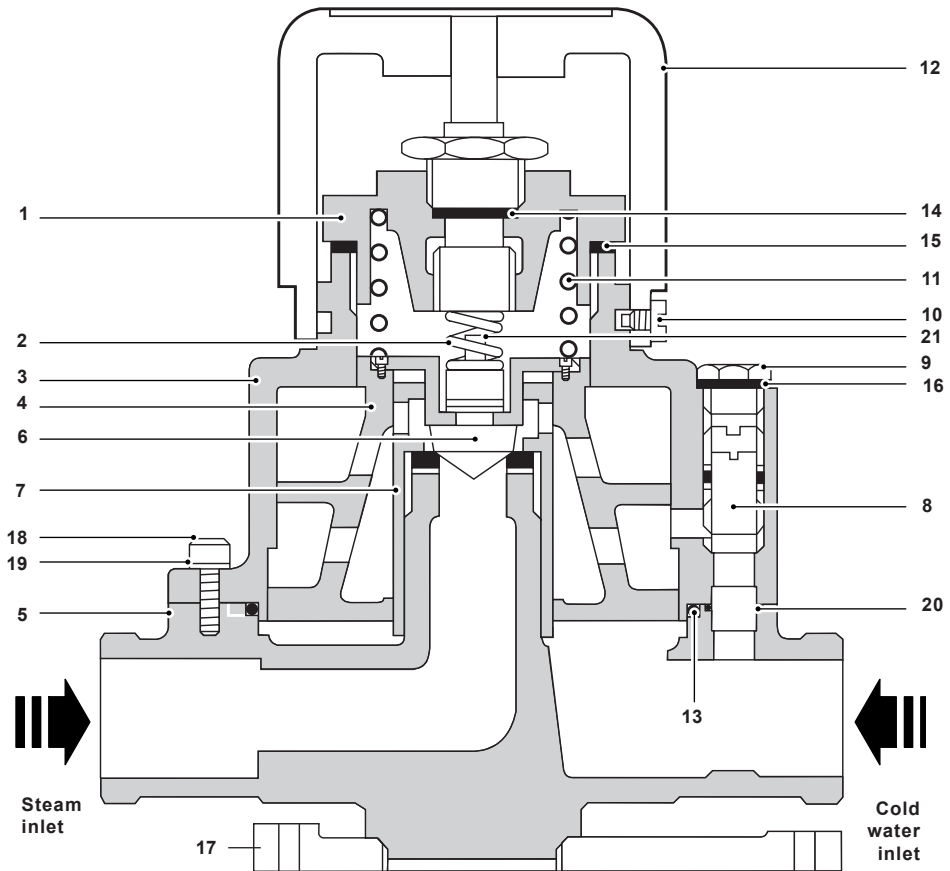

Fig. 14a 1" valve shown

5. Maintenance

Note:

Before actioning any maintenance programme observe the 'Safety information' in Section 1.

5.1 Importance of cleaning

Regular cleaning of the mixing valve and hose gun is required to prevent scale build-up and continued safe operation. This is especially important if they are used in hard water areas. In the event of mixing valve failure the TCO1 will operate and close at a temperature of 95 °C (203 °F). It is not re-settable and the mixing valve must be inspected in order to discover the reason for the valve going over temperature, and serviced before the temperature sensitive element in the TCO1 is replaced. If inspection of the mixing valve has not explained the reason for the TCO1 failure, the rest of the mixing valve station and all supply pipework and attendant pressures must be reviewed until the fault has been traced and rectified; please see Section 7, 'Fault finding'. The hosedown station must not be used until any rectification work has been completed. **The element must be replaced before recommencing operation of the hosedown station.**

The spares pack (see Section 6) is the same for ½" and ¾" hosedown stations.

The hosedown station must always be operated with an element in the TCO1 to prevent steam reaching the hose. In the event that the hosedown station is used without an element in the TCO1 then Spirax Sarco will not accept any consequential liability for the operation of the hosedown station in this manner.

Following operation of the TCO1, the hose and hosedown gun should be inspected for any sign of wear or damage. The hosedown station should form part of a regular maintenance programme, appropriate to the operating conditions and environment.

5.2 Cleaning procedure

(To be carried out by suitably qualified persons only)

When carrying out cleaning of the valve consideration should be given to total valve refurbishment by fitting a maintenance kit. Turn off and isolate the steam and water supplies, remove any residual pressure from the system by operating the hose gun and remove the gun from the hose. If the gun is to be cleaned (Reassemble the gun to the hose following Figures 9, 10 and 11). Undo the 3 union joints and remove the mixing valve from its fixings and move it to a maintenance area. Before reassembly ensure all union joint gasket faces are clean and ready to receive the new gaskets.

Referring to Figure 14b.

Remove the temperature adjustment knob (12) by loosening the holding screw (10). Unscrew the upper head (1) and remove the fixed loading spring (11). Remove the upper body (3) by taking out the 8 x 6 mm set screws (½" and ¾" mixing valve); 8 x 8 mm set screws (1" and 1½" mixing valve). The upper and lower bodies may be eased apart. All parts should now be cleaned using a proprietary de-scaler.

Note: Metal scrapers should not be used as this may cause permanent damage to the components. Before reassembly please ensure that all sealing surfaces are clean ready to receive the new gaskets and 'O' rings. (If the valve plug (6) is worn or damaged this should be replaced). Reassemble the mixing valve and test for correct operation.

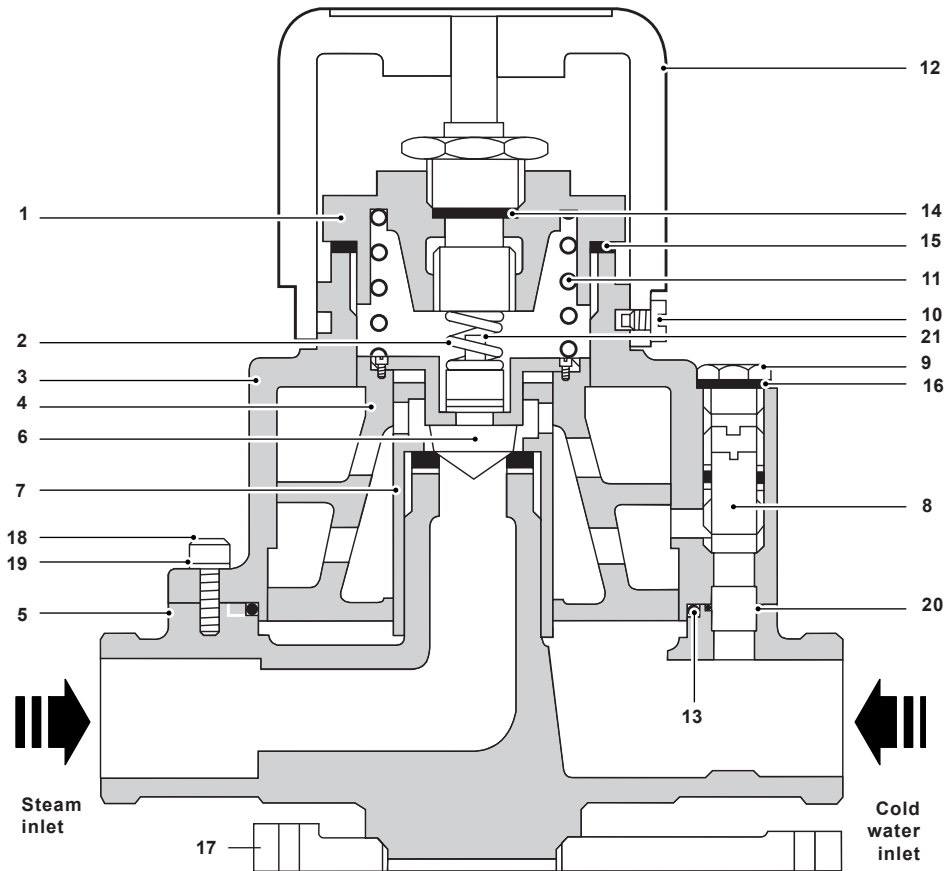

Fig. 14a 1" valve shown

5.3 Stripping down for service and fitting of maintenance kit 1/2" and 3/4" mixing valves only

To renew the PTFE seat steam valve assembly and bypass valve. (Figure 15 item nos. **6, 7 and 8**). Whenever possible remove the mixing valve from the pipework (this will enable the work to be carried out much more easily and will save time in the long run). Discharge the contents of the hose and station by pulling the gun trigger and eliminate pressure until water flow stops. Undo the 3 union joints and remove the mixing valve from its fixings (the 'T' piece and TCO1 can then be unscrewed). Before reassembly ensure all union joint gasket faces are clean and ready to receive the new gaskets.

Please read in conjunction with Figure 15:

1. Remove the temperature adjustment knob (**12**) by loosening the screw (**10**).
2. Remove the upper head (**1**). (R/H thread).
3. Remove the fixed loading spring (**11**).
4. Remove the steam valve spring (**2**).
5. Remove the upper body (**3**) and replace the top gasket (**15**) and body 'O' ring (**13**).
6. Remove the bypass screw (**9**), remove the bypass valve (**8**) and refit with the replacement parts. Replace the bypass valve washer (**16**).
7. Remove the upper retaining cap, using a two prong tool or 1¹/₁₆" A/F box spanner. The piston is free to rotate. The piston must therefore be held in order to remove the upper retaining cap. This is achieved by placing 2 x 1/4" diameter Tommy bars through the holes in the piston at 180° to each other.
8. Lift out the steam valve plug assembly (**6**).
9. Lift out the silencer plate.
10. Remove the 3 stainless steel screws.
11. Remove the valve retaining plate.
12. Remove the PTFE valve seat housing assembly (complete) using a 1¹/₁₆" A/F box spanner.
13. Remove the copper washer (**7B**).
14. To reassemble do the reverse of the break down procedure.

Before reassembly please ensure that all sealing surfaces are clean ready to receive the new gaskets and 'O' rings. Reassemble the mixing valve and test for correct operation.

Torque setting notes:

- i) The torque setting for the upper head (**1**) to upper body (**3**) is 120 - 130 N m (88 - 96 lbf ft).
- ii) The torque setting for the upper retaining cap to piston (**4**) is 30 - 35 N m (22 - 26 lbf ft).
- iii) The torque setting for the valve seat housing assembly (**7A**) to lower body (**5**) is:
35 - 40 N m (26 - 29 lbf ft).
- iv) The torque setting for upper body (**3**) to lower body (**5**), caps screws (**18**) is: 13 - 15 N m (10 - 11 lbf ft).

IMPORTANT PLEASE ENSURE THAT:

- a. The copper washer (7B) fits correctly between the PTFE valve seat housing assembly (7A) and steam inlet valve.
- b. The steam silencer plate is fitted with the three rivet heads against the PTFE valve seat housing assembly (7A) i.e. rivets not visible.
- c. The piston moves freely up and down, before fitting the springs and final assembly.
- d. When refitting the upper body (3), the 8 x cap screws (18), should be tightened progressively.

Note: Thermometer is replaced by simply loosening the grub screw in the pocket, removing the thermometer and sliding in a new one.

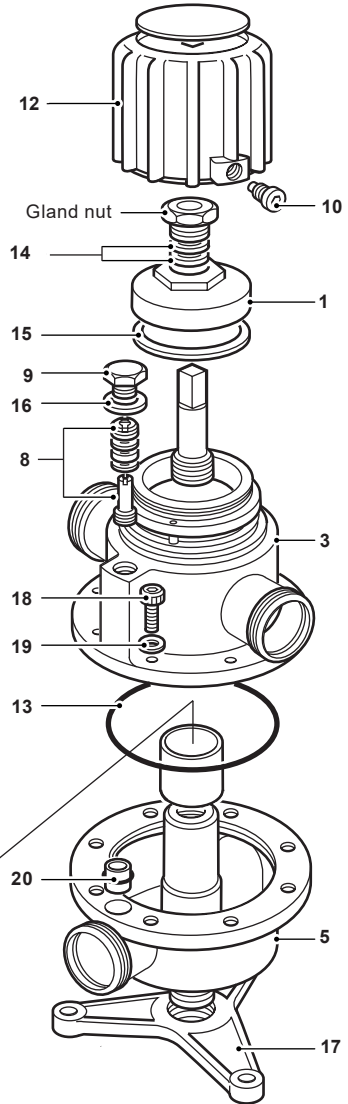
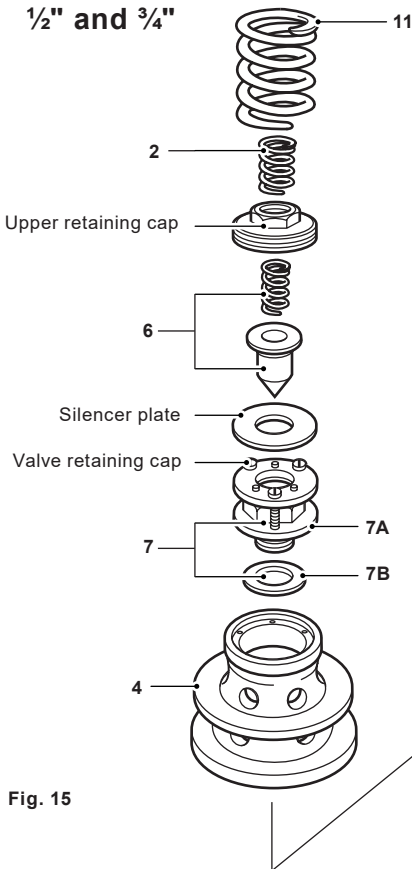

Fig. 15

5.5 Hose

The hose should be inspected before use for evidence of wear. If there are breaks in the external surface of the hose, it must be replaced immediately.

Note: hoses should be replaced after 12 months service. This is due to natural degradation of rubber under hot water working conditions.

5.6 Swivel coupling

Please read in conjunction with Steps 1 to 10. Procedure for replacing swivel coupling.

Swivel coupling maintenance Important - Inspection of internal seals:

- The swivel coupling should be periodically inspected e.g. during routine maintenance procedures, for evidence of wear on the internal seals. During normal usage, the swivel action of the coupling acts upon these seals and a slight leakage may occur if the seals are allowed to wear excessively. Under normal operating conditions the seals should be replaced every two years.
- Separate the hose tail from the gun retaining nut by unscrewing the hose tail using 1 $\frac{1}{8}$ " A/F and $\frac{7}{8}$ " A/F spanners.
- Remove the circlip from the swivel cylinder and push the cylinder out from the retaining nut.
- Check the two seals around the swivel cylinder for wear. If required, remove the seals e.g. by cutting with a sharp knife. Roll the new seals onto the cylinder and into the two seal grooves. **Do not** attempt to roll the seals over the threaded section of the cylinder, as this may cause damage to the new seals.
- Push the cylinder back into the retaining nut and secure with the circlip.

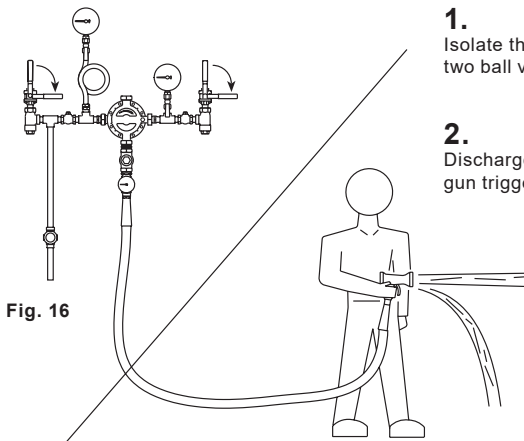

1.
Isolate the steam and cold water supplies by closing the two ball valves.

2.
Discharge contents of the hose and station by pulling the gun trigger and eliminate pressure until water flow stops.

3.

The replacement can be carried out with the hose still attached to the mixing valve or removed from the valve.

4.

Remove the gun from the hose by separating the swivel coupling. Use 1⁵/₁₆" A/F and 7/8" A/F spanners.

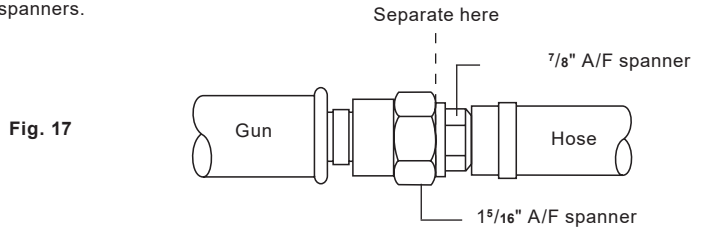

5.

Unscrew the gun from the retaining nut using an 1¹/₁₆" A/F spanner on the spanner flats of the retaining nut. Tighten to 50 N m (37 lbf ft). On older 3/4" units insert a 12 mm A/F hex. allen socket into the gun handle to a torque of 50 N m (37 lbf ft).

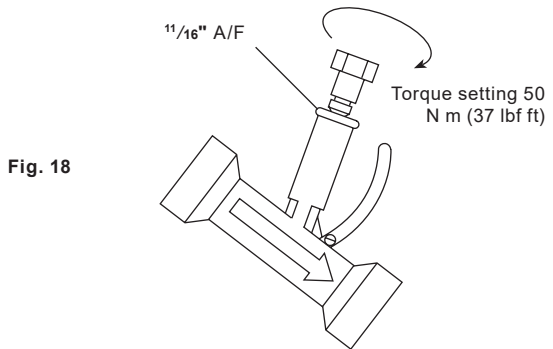

6.

Remove the hose tail of the swivel coupling from the hose by cutting the hose beyond the hose tail and crimped band.

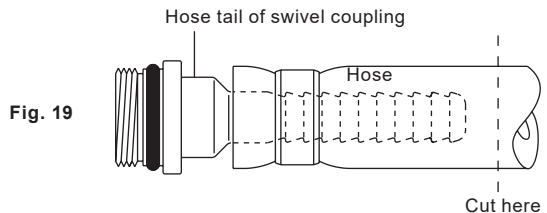

7.

The swivel coupling is supplied as a complete item. Separate into two pieces by unscrewing the hose tail using 1⁵/₁₆" A/F and 7⁷/₈" A/F spanners.

Apply PTFE tape or sealant

Fig. 20

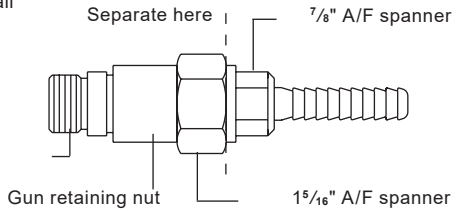

8.

A thread sealant or PTFE tape should be applied to the male thread of the gun retaining nut. Screw the retaining nut into the gun using an 1¹/₁₆" A/F spanner to 50 N m (37 lbf ft). On older 3⁴/₄" units a 12 mm allen drive socket is required.

Torque setting 50 N m (37 lbf ft)

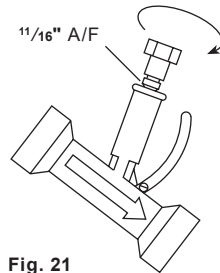

Fig. 21

9.

Push new hose tail into hose and secure to prevent movement, using a suitable fastening system, e.g. "BAND-IT" Preformed clamp.

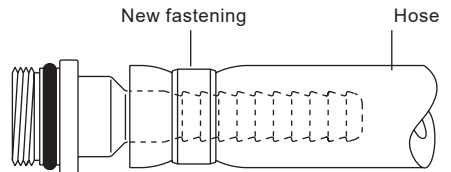

Fig. 22

10.

Connect the gun to the hose by reassembling the two halves of the swivel coupling. Tighten to a torque setting of 50 N m (37 lbf ft).

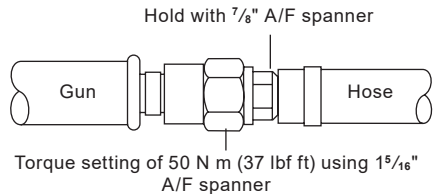

Fig. 23

5.7 Hosedown gun

The same policy should be followed regarding the gun. A leaking gun should be repaired or replaced immediately.

Please read in conjunction with Figure 24:

1. Isolate the steam and cold water supplies by closing the two ball valves.
2. Discharge the contents of the hose and the station by pulling the gun trigger and eliminate pressure until the water flow stops.
3. Remove the gun from the hose by separating the swivel coupling. Use 1 $\frac{1}{16}$ " A/F and $\frac{7}{16}$ " A/F spanners.
4. Unscrew the gun from the gun retaining nut of the swivel coupling.
5. Place the gun in a tub of warm water to soften the rubber cover.
6. Ease the cover off the back of the gun and secure the gun in for example a vice by clamping the rear end of the body and ease the cover over the front of the gun.
7. Unscrew the nozzle from the gun body.
8. Remove the end screw from the rear of the gun. (The end cap will be loose in the gun body). Remove the piston (a and b) and the spring from the gun body.
9. Remove the top screw from the top of the gun body so that the cylinder can be taken out of the gun body.
10. To replace the internals, reverse the removal procedure. In order to do this two points should be considered: The piston is despatched in two parts (a and b); these must be screwed together before installation. When securing the cylinder rotate it until the hole in the cylinder lines up with the hole in the gun body. If the cover only is being replaced, then follow Steps, 1 to 6; remove the gun from the vice to fully take off the handle part of the cover. To replace a cover, reverse the removal procedure.

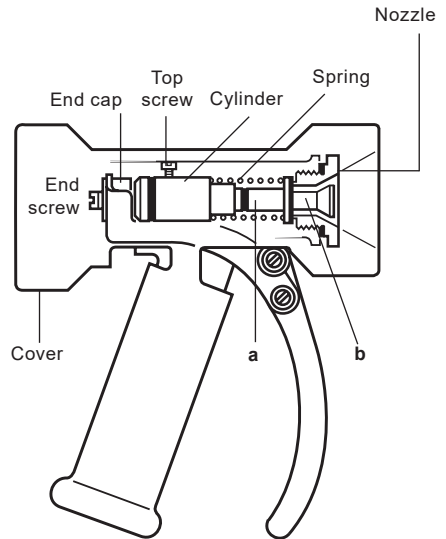

Fig. 24

5.8 TCO1

Please read in conjunction with Figure 25:

If the TCO1 temperature cut-out valve has fired, the hosedown station arrangement must be examined to understand the reason for the failure. This should then be rectified before replacing the TCO1 element so that failure does not occur again.

1. Isolate the steam and cold water supplies by closing the two ball valves.
2. Discharge the contents of the hose and station by pulling the gun trigger and eliminate pressure until the water flow stops.
3. Undo the cap from the body using a 1" A/F spanner and remove the element.

Replace the element and tighten the cap to a torque of 50-55 N m (37 - 40 lbf ft).

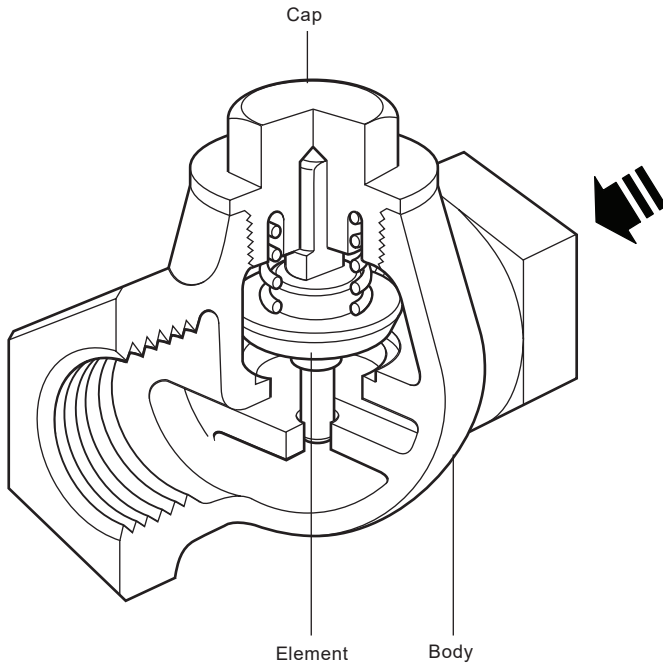

Fig. 25

5.9 TCO1 Retro-fit pack

Please read in conjunction with Figure 26:

The TCO1 temperature cut-out valve can be retro-fitted to Spirax Sarco steam/water mixing valves that do not already have them fitted. **This is strongly recommended.** The practice of retro-fitting a TCO1 will only apply to some older installations where a TCO1 was not supplied with the original valve. This does not apply to the valve design that is shown throughout this IMI. The procedure outlined below is therefore for the old type of valve. There is only one size of TCO1 (1" nominal bore) which is suitable for both ½" and ¾" steam/water mixing valves.

Installation:

1. Isolate the steam and cold water supplies by closing the two ball valves.
2. Discharge the contents of the hose and station by pulling the gun trigger and eliminate pressure until the water flow stops.
3. Remove the hose by splitting the union and unscrew the thermometer 'T' from the mixing valve hot water inlet. Remove the nipple from the valve end of the 'T' piece.
4. Assemble the TCO1 retro-fit pack; Screw the 1" x ½" reducing nipple into the TCO1 marked 'INLET' for the ½" mixing valve, (for the ¾" mixing valve it is a 1" x ¾" reducing nipple). Screw the 1" x ¾" reducing nipple into the TCO1 marked 'OUTLET', (this is the same for both the ½" and ¾" mixing valves.)
5. Attach the thermometer 'T' piece to the TCO1 retro-fit pack.
6. Screw the TCO1 retro-fit pack into the hot water outlet of the mixing valve using PTFE tape or suitable thread sealant. Care should be taken to ensure that the hexagon cap is in line with the dial face of the thermometer when the arrangement is tightened into the valve.
7. Attach the hose to the thermometer 'T' piece using the union.

IMPORTANT NOTE:

The TCO1 must be installed with the end marked 'INLET' connected to the mixing valve and the end marked 'OUTLET' to the 'T' piece. (These markings are stamped onto the hexagon end connections). The TCO1 is a safety device, if it is installed in reverse it will never be able to operate.

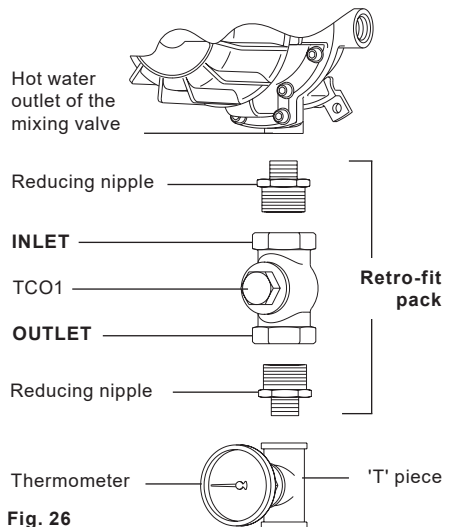

Fig. 26

5.10 Stripping down for service and fitting of maintenance kit 1" and 1½" mixing valves only

To renew the PTFE seat, steam valve assembly and bypass valve. (Figure 27 item nos. **6**, **7** and **8**). It is necessary to remove the mixing valve from the pipework (this will enable the work to be carried out much more easily and will save time in the long run).

Please read in conjunction with Figure 12:

1. Remove the temperature adjustment knob (**12**) by loosening the screw (**10**).
2. Remove the upper head (**1**) (R/H thread).
3. Remove the fixed loading spring (**11**) (and spring top guide, 1½" size only).
4. Remove the steam valve spring (**2**). **Note 1½" size does not have this spring.**
5. Remove the spigoted spring guide (**21**).
6. Remove the upper body (**3**) and replace the top gasket (**15**), the body 'O' ring (**13**) and bypass valve 'O' ring (**20**).
7. Remove the bypass screw (**9**), remove the bypass valve (**8**) and refit with replacement parts. Replace the bypass valve washer (**16**).
8. Remove the steam valve plug assembly (**6**) from the piston (**4**) by removing the holding screws.
9. Remove the steam valve housing by means of a 5/16" diameter Tommy bar (for 1" valve and ¼" diameter for 1½" valve) passed through the holes in the piston (**4**) and through the holes in the steam valve housing. **Note:** the piston (**4**) will have to be raised slightly to align this.
10. Remove the crinkle and pressure washers and PTFE seat.
11. To reassemble do the reverse of the break down procedure.

Before reassembly please ensure that all sealing surfaces are clean ready to receive the new gaskets and 'O' rings. Reassemble the mixing valve and test for correct operation.

IMPORTANT PLEASE ENSURE THAT:

- a. The PTFE seat and pressure plates must be assembled as follows:
 - First install the PTFE seat in contact with the steam inlet valve.
 - Place the plain pressure washer on top of the PTFE seat.
 - Finally install the Beryllium copper crinkle washer on top of the pressure washer; the crinkle washer must be in contact with the steam valve housing.
- b. Ensure the piston (**4**) moves freely up and down, before fitting the springs and final assembly. The securing screws should be tightened progressively.
- c. When renewing the steam valve plug assembly (**6**), to prevent the securing nut becoming loose during working conditions, stake the steam valve plug to the nut with three dots using a centre punch.
- d. When refitting the upper body (**3**), the 8 x cap screws (**18**) should be tightened progressively, to a torque setting of 13-15 N m (10 - 11 lbf ft).

It is essential that for all sizes a certain amount of 'float' on steam valve assembly is provided, to allow for self-centering.

Note:
The 1½" body (3) has internal (female) threads (shown), the 1" has external (male) threads.

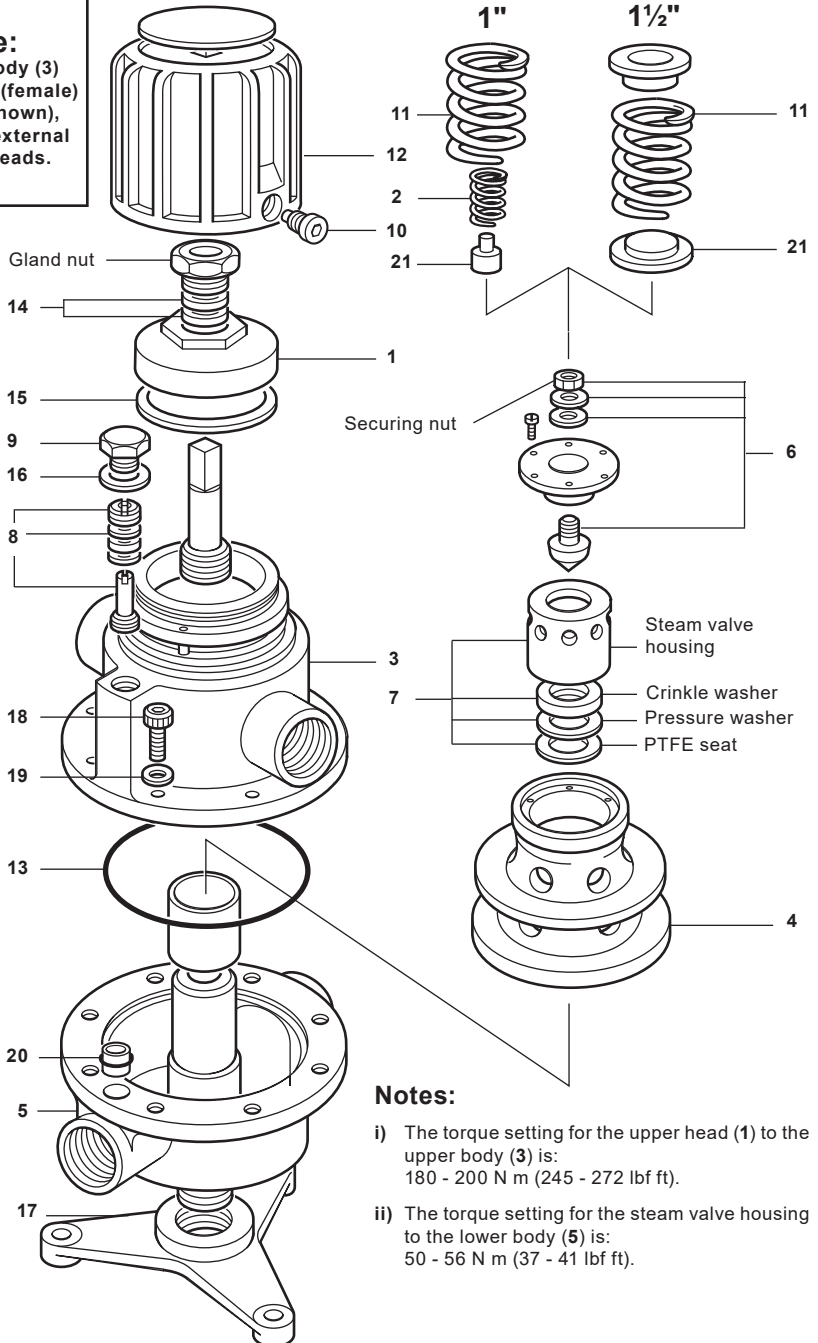

Notes:

- i) The torque setting for the upper head (1) to the upper body (3) is:
180 - 200 N m (245 - 272 lbf ft).
- ii) The torque setting for the steam valve housing to the lower body (5) is:
50 - 56 N m (37 - 41 lbf ft).

Fig. 27

6. Spare parts

How to order spares:

The spare parts available are detailed in this Section. No other parts are supplied as spares.

Example: 1 off Maintenance kit for 1/2" steam/water mixing valve.

Note: For hosedown station ancillaries, please see separate TI's.

6.1 Mixing valve spares

Maintenance kit	2, 6, 7, 8, 13, 14, 15, 20
Gasket set	13, 14, 15, 16, 20
Fixed loading spring	11, 15

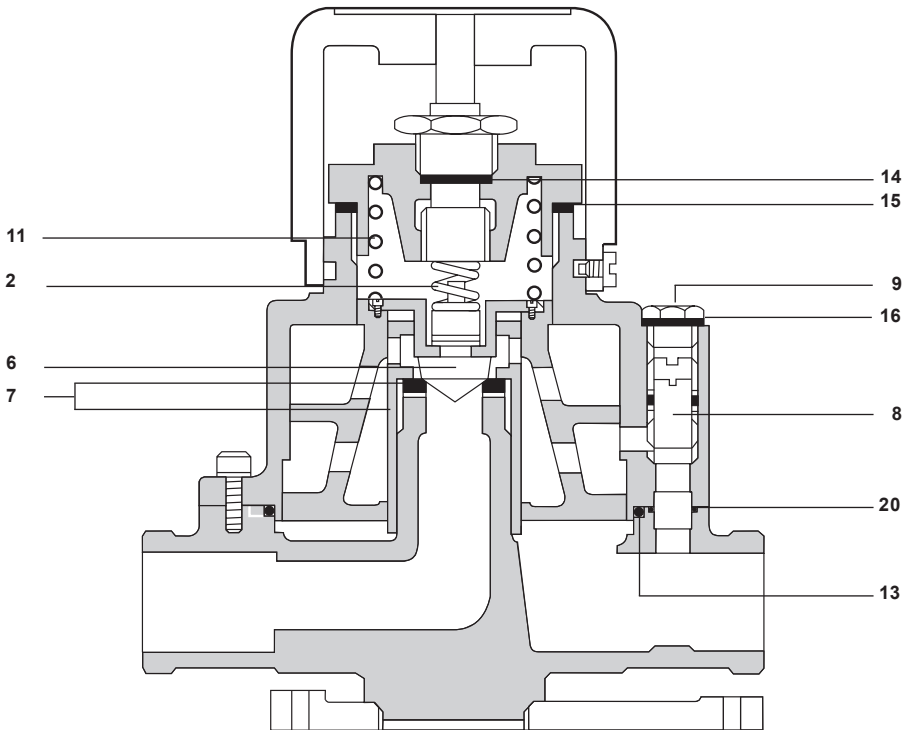

Fig. 28 1" valve shown

6.2 Thermometer spares

Thermometer set	2, 3
Thermometer	1

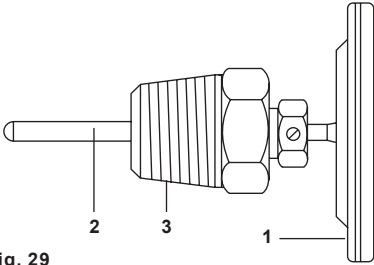

Fig. 29

6.3 Hose spares

Swivel coupling	1
-----------------	---

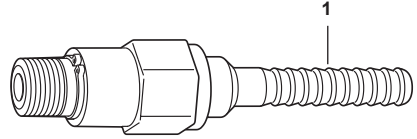

Fig. 30

6.4 Hosedown gun spares

Rubber cover for gun body	1
Internal spares kit	2

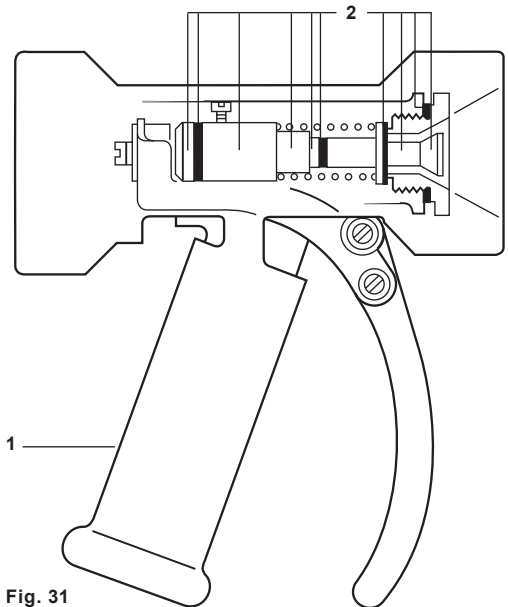

Fig. 31

6.5 TCO1 spares

Element	1
---------	---

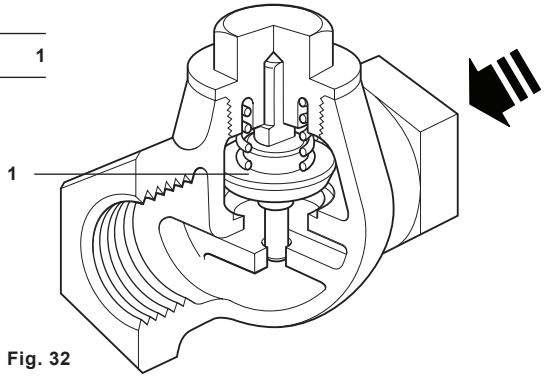

Fig. 32

6.6 Retro-fit pack

TCO1 temperature cut-out valve	1
Reducing nipples	2

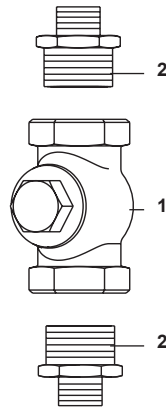

Fig. 33

7. Fault finding

Before investigating further it is always advisable to check the following:-

Ensure that the steam and water supplies are turned on and have running condition pressures in excess of 3.0 bar g (43.5 psi g) for cold water, for hosesdown stations. The pressure gauges show whether the expected supply pressures are reaching the mixing valve.

Symptom	Cause and corrective action
Gland leaking	<p>When the mixing valve has been in operation for a short time it is possible that the gland packing (14) may leak very slightly. The gland nut should then be tightened. Continual leakage may cause the knob to seize.</p> <p>Note: Check gland tightness after a few days operational service.</p>
Valve delivers cold water only	<p>Hot water supply Disconnect the downstream pipework or hose from the valve outlet, and check if the hot water flows. Before operating the valve, ensure adequate safety procedures are in place to prevent injury from the hot discharge. Operate valve slowly. If hot water is now flowing the downstream pipework is causing too much resistance. Please refer to Table 1, page 6 and alter pipework to suit.</p> <p>Incoming steam supply line - is steam reaching the mixing valve? Check the pressure on the gauge prior to the ball valve. If this is zero or lower than expected, check that all supply isolating valves are fully open; check strainers are not blocked, (including steam/water mixing valve strainer); ensure that the inlet check valve is installed with direction of flow arrow in the right direction. Ensure that the check valve cone is free to move.</p> <p>Fixed loading spring Check that the correct fixed loading spring (11) is fitted. Replace with the lower rated spring if necessary.</p>
Hot water outlet temperature too low	<p>Fixed loading spring Check that the correct fixed loading spring (11) is fitted. Replace with low the lower rated spring if necessary.</p> <p>Bypass valve setting Turn the temperature adjustment knob (12) to the right as far as possible, it may be necessary to remove the knob retaining screw (10), so that the knob can be moved the other side of an internal stop in the valve body. Measure the temperature, if correct remove the temperature adjustment knob (12) and replace in a position 45° anticlockwise from its previous position. If the temperature is not correct remove the bypass screw (9) insert a screwdriver and turn the bypass valve (8) clockwise. Measure the temperature, if incorrect continue to turn the bypass valve clockwise, if incorrect refit screw (9). If the temperature is still too low and the bypass valve has been turned fully clockwise, then the cold water supply should be reduced by the installation of an LRV water reducing valve.</p> <p>Condensate problem Incoming steam pipework must be free of condensate, which would pass slowly through the steam inlet valve and the mixed water would take longer to heat up. This may not appear to be a problem if the valve has been commissioned with a waterlogged steam line, however condensate can cause waterhammer, and the steam line should be properly drained using a steam trap. The incoming steam line should always be taken off the top of the steam main.</p>

Symptom	Cause and corrective action
<p>Hot water outlet temperature too low</p>	<p>Difference in supply pressures (see page 16) When a mixing valve is supplied with a higher cold water pressure compared to a lower steam pressure, in some instances it is possible that there will be too much cold water for the steam to heat up. It is also possible that steam will be prevented from entering the mixing valve, due to a higher cold water pressure. A Spirax Sarco LRV pressure reducing valve would need to be installed in the cold water supply line to reduce cold water pressure. This is why it is recommended that the supply pressures are nominally equal.</p>
<p>Hot water temperature too high</p>	<p>Temperature adjustment knob position The mixing valve is supplied with the temperature adjustment knob (12) set to the highest setting, fully turned clockwise. To reduce the outlet temperature the knob should be turned anticlockwise. However, if the temperature adjustment knob is at full travel anticlockwise against the stop and the temperature is still too high, remove the retaining screw (10) and adjustment knob and reposition on the spindle to a similar position to its original location. The knob is now in a position that it can be turned anticlockwise to reduce the temperature. This operation may have to be repeated.</p>
	<p>Cold water supply Intermittent cold water supply If the cold water supply pressure or flowrate fluctuates, the mixed hot water temperature will also vary accordingly. This would occur where there are take-offs prior to the mixing valve. If the supply cold water pressure or flowrate falls the hot water temperature will rise. For sites known to have intermittent cold water supplies a feedtank and booster pump should be considered. This is very important in the U.K. where an air gap is required using a feedtank, after changes in Water Bye Laws. If a booster pump is being used to supply an adequate constant cold water supply pressure, then pressure switches must not be used, since this can affect the operation of the steam/water mixing valve station. Installation of a balanced line arrangement should be considered; (a typical layout is shown in Figure 12).</p> <p>Is cold water reaching the ball valve? Check the pressure on the gauge prior to the ball valve. If this is zero or lower than expected, check that all supply isolating valves are fully open; check strainers are not blocked, (including steam/water mixing valve strainer); ensure that the inlet check valve is installed with the direction of flow arrow in the right direction. Ensure that the check valve cone is free to move.</p> <p>Scale and dirt Scale and dirt can hold the steam valve open. The mixing valve should be cleaned and a maintenance kit fitted (see Section 5).</p> <p>Fixed loading spring Check that the correct fixed loading spring (11) is fitted. Replace with the higher rated spring if necessary.</p> <p>Steam pressure too high If the steam supply pressure is 1.5 times greater than the highest fixed loading spring the steam valve can leak. Replace with a higher rated spring. If this is not high enough then the boiler steam pressure needs to be reduced with a BRV or DP17 pressure reducing valve.</p>

Symptom	Cause and corrective action
<p>TCO1 operates</p> <p>Hot water temperature too high</p>	<p>Inspect and service valve If the internals of the mixing valve are free of scale or the valve has just been serviced or is new, check the following:</p> <p>Constant cold water pressure a) The mixing valve should be supplied with a constant cold water pressure. If this supply fluctuates, the mixed hot water temperature could rise above 95 °C (203 °F) and the TCO1 will be activated. This could occur on valves that are installed off the mains. This installation has now been banned by the U.K. Water Authorities. If a booster pump is being used to supply an adequate constant cold water supply pressure, then pressure switches must not be used, since this can affect the operation of the steam/water mixing valve station. Installation of a balanced line arrangement should be considered; (a typical layout is shown in Figure 12, page 17).</p> <p>Difference in supply pressures (see page 12) b) When a mixing valve is supplied with a higher steam pressure compared to a lower cold water pressure, in some instances it is possible to produce hot water in excess of 95 °C (203 °F). It is also possible that steam can exit the mixing valve as the steam valve can remain open in some instances, if the supply pressures are not nominally equal. A BRV pressure reducing valve would need to be installed in the steam line to reduce pressure. This is why we recommend that the supply pressures are nominally equal.</p>

