

spirax
/sarco
STAPS
Wireless Head Unit
Quick Installation Guide



1. Safety information
2. General product information
3. Order of installation
4. Installation of head
5. Spare parts
6. Certification and approvals
7. Technical data
8. Technical glossary

1. Safety information

Safe operation of this unit can only be guaranteed if it is properly installed, commissioned and maintained by a qualified person (see Section 1.11) in compliance with the operating instructions. General installation and safety instructions for pipeline and plant construction, as well as the proper use of tools and safety equipment must also be complied with.

Manufacturer - Spirax-Sarco Limited,
Charlton House, Charlton Kings, Cheltenham, Gloucestershire, UK, GL53 8ER

The product is designed and constructed to withstand the forces encountered during normal use. Use of the product for any other purpose, or failure to install the product in accordance with these Installation and Maintenance Instructions, could cause damage to the product, will invalidate the CE marking, and may cause injury or fatality to personnel.

1.1 Intended use

Referring to the Installation and Maintenance Instructions, name-plate and Technical Information Sheet, check that the product is suitable for the intended use/application.

- i) The product has been specifically designed for use on saturated steam systems.
- ii) Check material suitability, pressure and temperature and their maximum and minimum values.
- iii) Determine the correct installation situation and direction of fluid flow.
- iv) Spirax Sarco products are not intended to withstand external stresses that may be induced by any system to which they are fitted. It is the responsibility of the installer to consider these stresses and take adequate precautions to minimise them.

1.2 Access

Ensure safe access and if necessary a safe working platform (suitably guarded) before attempting to work on the product. Arrange suitable lifting gear if required.

1.3 Lighting

Ensure adequate lighting, particularly where detailed or intricate work is required.

1.4 Hazardous liquids or gases in the pipeline

Consider what is in the pipeline or what may have been in the pipeline at some previous time. Consider: flammable materials, substances hazardous to health, extremes of temperature.

1.5 Hazardous environment around the product

Consider: explosion risk areas, lack of oxygen (e.g. tanks, pits), dangerous gases, extremes of temperature, hot surfaces, fire hazard (e.g. during welding), excessive noise, moving machinery.

1.6 The system

Consider the effect on the complete system of the work proposed. Will any proposed action (e.g. closing isolation valves, electrical isolation) put any other part of the system or any personnel at risk?

Dangers might include isolation of vents or protective devices or the rendering ineffective of controls or alarms. Ensure isolation valves are turned on and off in a gradual way to avoid system shocks.

1.7 Pressure systems

Ensure that any pressure is isolated and safely vented to atmospheric pressure. Consider double isolation (double block and bleed) and the locking or labelling of closed valves. Do not assume that the system has depressurised even when the pressure gauge indicates zero.

1.8 Temperature

Allow time for temperature to normalise after isolation to avoid the danger of burns and consider whether protective clothing (including safety glasses) is required.

1.9 Tools and consumables

Before starting work ensure that you have suitable tools and/or consumables available. Use only genuine Spirax Sarco replacement parts.

1.10 Protective clothing

Consider whether you and/or others in the vicinity require any protective clothing to protect against the hazards of, for example, chemicals, high / low temperature, radiation, noise, falling objects, and dangers to eyes and face.

1.11 Permits to work

All work must be carried out or be supervised by a suitably competent person. Installation and operating personnel should be trained in the correct use of the product according to the Installation and Maintenance Instructions.

Where a formal 'permit to work' system is in force it must be complied with. Where there is no such system, it is recommended that a responsible person should know what work is going on and, where necessary, arrange to have an assistant whose primary responsibility is safety.

Post 'warning notices' if necessary.

1.12 Handling

Manual handling of large and/or heavy products may present a risk of injury. Lifting, pushing, pulling, carrying or supporting a load by bodily force can cause injury particularly to the back. You are advised to assess the risks taking into account the task, the individual, the load and the working environment and use the appropriate handling method depending on the circumstances of the work being done.

1.13 Residual hazards

In normal use the external surface of the product may be very hot. If used at the maximum permitted operating conditions the surface temperature of some products may reach temperatures of 425°C (797°F).

Many products are not self-draining. Take due care when dismantling or removing the product from an installation (refer to 'Maintenance instructions').

1.14 Freezing

This product does not contain fluid that will freeze, however lower temperatures will affect the product performance. Do not subject the product to temperatures below the stated minimum.

1.15 Disposal

Unless otherwise stated in the Installation and Maintenance Instructions, this product is recyclable and no ecological hazard is anticipated with its disposal providing due care is taken. The product should be recycled in line with local legislation. Special attention should be paid to the battery, see section 1.17.

1.16 Returning products

Customers and stockists are reminded that under EC Health, Safety and Environment Law, when returning products to Spirax Sarco they must provide information on any hazards and the precautions to be taken due to contamination residues or mechanical damage which may present a health, safety or environmental risk. This information must be provided in writing including Health and Safety data sheets relating to any substances identified as hazardous or potentially hazardous. Refer to section 1.17 with regards to shipping/returning of the lithium batteries.

1.17 Battery

The Head unit is powered by a Lithium battery (SAFT LS 33600 3.6 V cell).

Handling considerations:

- Do not crush, pierce, short (+) and (-) battery terminals with conductive (i.e. metal) goods.
- Do not directly heat or solder.
- Do not throw into a fire.
- Do not mix batteries of different types and brands.
- Do not mix new and used batteries.
- Keep batteries in non-conductive (i.e. plastic) trays.
- Do not subject the battery to temperatures above 100°C

Storage

Store in a cool (preferably below 30°C), dry, clean and well-ventilated area.

Environmental consideration

As with any battery, local environmental regulations must be adhered to with regard to disposal of spent batteries. Special attention must be paid not to mix with other types of batteries.

Battery hazards remain even when the cells are discharged.

Shipping considerations

Transport of Lithium batteries is regulated by many authorities. i.e.:

- ADR (European Ground Transportation),
- IATA (International Air Transport Association),
- ICAO (International Civil Aviation Organisation) and the Regulations concerning the International Carriage of Dangerous Goods by Rail (Intergovernmental Organisation for International Carriage by Rail).

It is the responsibility of the shipper to ensure that these regulations are followed.

1.18 Use of non genuine components or spare parts

This product is certified by a number of health and safety regulatory bodies for health and safety and environmental purposes. To maintain the approvals only genuine components and spare parts must be used. This includes consumable items such as the SAFT battery and power supplies.

2. General product information

2.1 General description

The STAPS wireless steam trap monitoring system has been designed to efficiently monitor and evaluate steam trap operation. It surveys the operation of the steam trap at regular intervals and identifies poor performance that can cause reduced plant efficiency and increased energy consumption. It can diagnose both failed-open steam traps that leak live steam, and those that have failed-closed or are blocked, resulting in waterlogging, leading to plant damage, product spoilage and health and safety concerns.

Using non-intrusive installation technology combined with a 2.4 GHz wireless network, it is an ideal solution for steam trap monitoring. It is suitable for use with all types of steam trap and can be connected to pipework up to 100 mm (4"), via an adjustable clamp.

How does it work?

A head unit assembly mounted on the pipe upstream of the trap to be monitored 'listens' to the sound signature of the trap in operation. This sound signature is categorised and transmitted via 2.4 GHz wireless network to a central PC. The PC determines the trap condition and calculates any steam loss - See software IMI for commissioning the unit into operation.

Each STAPS head unit assembly is powered by a long life Lithium battery (typical battery life of over 3 years). It can communicate directly to a receiver that is connected to the PC software via a LAN connection or via another intelligent head or repeater. The PC software can be installed onto a PC on the sites internal network, or onto a stand-alone local PC. The STAPS head, repeater and receiver create a network and can communicate with each other, passing on the steam trap data to the supervisory PC.

2.2 STAPS head unit assembly

The STAPS head unit includes the head unit and the sensor and clamp that must be connected to the steam pipe upstream of the steam trap that it is monitoring. The head itself is supplied clamped to the sensor and connected via 1 m of cable.

The pipe clamp is available in four sizes to suit the following sized pipelines:

- 1 - ½" - 1¼"
- 2 - 1½"
- 3 - 2" - 2½" and
- 4 - 3" to 4".

There is also an option with a unique clamp to secure the head unit to a Spirax Sarco STS17 or STS17.2 pipeline steam trapping station. The head can be unclamped from the sensor and refitted remotely (up to 1 m) - See Section 3 for full instructions.

The battery powered head uses a 2.4 GHz radio to communicate to the receiver.

A head unit can also be configured to act as a repeater (intelligent head).



Fig. 1

3. Order of installation

3.1 Accompanying documents

The following Installation and Maintenance Instructions are required to complete the system installation:

IM-P014-16 STAPS Wireless Head Unit Quick Installation Guide

IM-P014-25 STAPS Wireless Receiver / Repeater Installation Guide

IM-P014-26 STAPS Wireless Steam Trap Monitoring System Installation and Operating Instructions for use with Windows 7 operating systems

Or

IM-P014-24 STAPS Wireless Steam Trap Monitoring System Installation and Operating Instructions for use with Windows XP operating systems

To ensure that the STAPS system operates correctly adhere to Section 3.2 and you must follow the sequence of installation specified in Section 3.3

3.2 Before Installation:

A preliminary site survey of the plant must be conducted by trained personnel, the survey will identify the optimum number of Receivers and Repeaters together with their most effective location, to give the most robust wireless network.

Ensure a discussion has taken place with your Network Administrator, showing them Section 4.1 of IM-P014-26 or IM-P014-24.

Observe the 'Safety Information' in each of the above documents.

3.3 Recommended order of installation:

1. Install the application software onto the supporting PC, refer to Section 4.2 of IM-P014-26 or IM-P014-24.
2. From the results of the site survey, carefully select the optimum position for the Receiver ensuring that there is a direct line of sight (20 - 30 m) with as many steam traps that are to be monitored as possible, referring to IM-P014-25.
3. Plug in the Receiver into the network point using an RJ45 cable plug.
4. Plug in the Receiver to the mains power supply, and proceed to switch it on.
5. After a short delay the Receiver symbol will appear in the network maintenance window on the PC application software, refer to Section 5.3 - Network Maintenance of IM-P014-26 or IM-P014-24.

If the Receiver is installed on a different sub-net to the PC, refer to Section 5.13 of IM-P014-26 or IM-P014-24.

If during the site survey it was identified that Repeaters are required complete Steps 6 to 9, if no Repeaters are required skip to Step 10.

6. Carefully select the optimum site for the Repeater ensuring that there is a direct line of sight (20 - 30 m) with as many steam traps that are to be monitored as possible, referring to IM-P014-25.
7. Plug in the Repeater to the mains power supply, and proceed to switch it on (do not plug a cable into the network connection).
8. After a short delay the Repeater symbol will appear in the network maintenance window on the PC application software, refer to Section 5.3 - Network Maintenance of IM-P014-26 or IM-P014-24.
9. Repeat Steps 6 to 8 if further Repeaters were recommended or required.
10. Fit a battery to the first Head, refer to IM-P014-16. As soon as the battery is connected into the Head it will start to transmit and will communicate with the Receiver or Repeater. This will show up on the PC software, after 15 to 30 minutes.

Please note:

If a Head is powered up without a Receiver being powered up first, the Head battery will discharge quickly as the Head is trying to associate itself with a network.

11. Install the Head unit to the upstream side of the assigned trap (within 150 mm).
12. Using the software, assign a trap to the Head, refer to Section 5.6 - Assigning traps to Heads IM-P014-26 or IM-P014-24.
13. Repeat Steps 6 to 8 for other STAPS Heads until all traps to be monitored within signal range are completed.
It is recommended to connect all of the Heads in each area of the network associated to a single Repeater or Receiver identified in the site survey.
14. When all the Heads and Repeaters under a Receiver are installed and reporting correctly, it is recommended that a unique PAN ID is set for that section of the network before continuing with other Receiver sections.
Refer to Section 5.8 of IM-P014-26 or IM-P014-24.

For full instructions on each step see individual sections.

4. Installation of the head unit assembly

Note: Before actioning any installation observe the 'Safety information' in Section 1.

The STAPS sensor includes the following parts:

- 1 off head and sensor assembly, including the head unit and sensor with top clamp, 'U' bolts and wing nuts, attached with 1 m of cable.



Slot used for size of pipe:

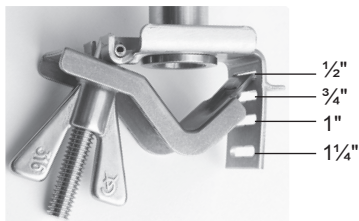

Fig. 2

- 1 off lower clamp with 'T' bolt and wing nut.

Size 1/2" – 1 1/4"



Fig. 3

Larger sizes use a top clamp with jubilee clips.

Size 1 1/2", 2"-2 1/2" and 3"-4"

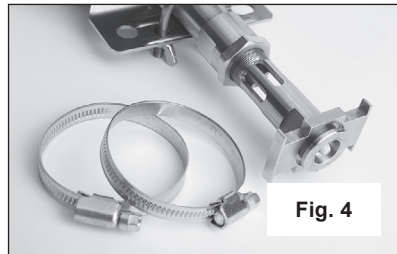

Fig. 4

Clamp for use with a Spirax Sarco STS17 or STS17.2 compact pipeline steam trapping station.



Fig. 5

- 1 off SAFT LS33600 3.6V



Fig. 6

Consider where the STAPS head unit is to be fitted:

- **The weather** - The head unit is IP65 rated.
- **Wireless signal objections** - Will adjacent buildings, pipework or other objects obstruct the wireless signal from reaching the nearest repeater/receiver?
- **Interference** - Is there any electrical or radio interference that may affect the performance of the STAPS head unit.
- **Access** - Is there sufficient access to the head to change the batteries for maintenance?
- **Installation** - Is there sufficient room at the sensor for the head to be mounted on the sensor or locally within 1 m?
- **Lagging** - Ensure that any pipe lagging in the area where the STAPS head is to be fitted is removed before fitting. **DO NOT re-lag the STAPS head unit, including the clamp and stem.**

4.1 Fitting the battery to the sensor head

The head unit assembly is supplied with a SAFT LS 33600 3.6 V battery loose in the box.

Note: It is highly recommended on initial installation that the battery is fitted whilst the head unit is on a workbench, before it is installed on site.

4.1.2 Unscrew the head cover retaining screw.



Fig. 7

-
- 4.1.3** Turn head cover anticlockwise and align the cover lug with the arrow on the body and pull the cover away from the body.



Fig. 8

-
- 4.1.4** Remove the packaging from the battery and push it into the holder in the head unit. Ensure that the battery is in the correct orientation as per the orientation marker (+ to top). Note: Only use a SAFT LS 33600 Lithium Thionyl Chloride 3.6 V battery.



Fig. 9

- 4.1.5** Refit the cover and retaining screw. Check that the 'O' ring seal is in good condition before refitting the cover, and is correctly seated in place.

4.2 Mounting the head unit

Ensure that any pipe lagging is removed from the area where the STAPS head is to be fitted. **DO NOT re-lag the STAPS Head.**

4.2.1 For pipe sizes 1/2" to 1 1/4"

Slide the tongue of the lower clamp into the appropriate slot of the top clamp.

Offer the head unit to the pipe within as close as possible but within 150 mm upstream of the steam trap to be monitored.

Hook the 'T' bolt over the top clamp and tighten the wing nut. Ensure that the head unit is fitted uppermost (on top of the pipe), no greater than a 45° angle.

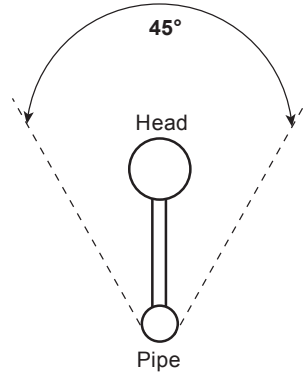

Fig. 10

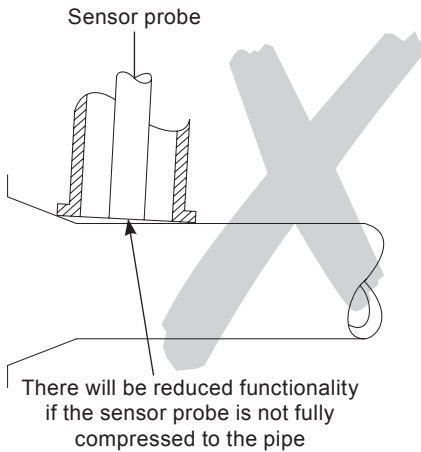

Fig. 11

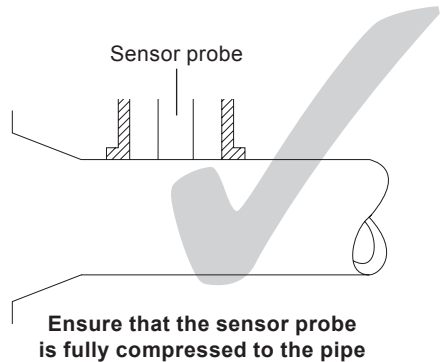

Fig. 12

Caution: If fitted to a hot pipe, recheck that the clamp is tight after 15 minutes.



Fig. 13

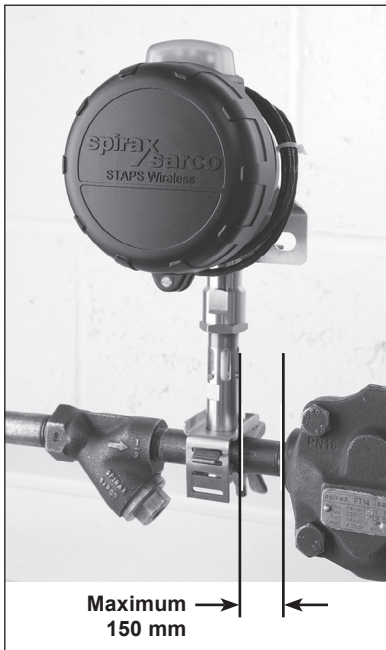

Fig. 14

4.2.2 For pipe sizes 1½", 2" - 2½" and 3" - 4"

The larger sizes use jubilee clips rather than a clamp to attach the head unit to the pipe. Separate the jubilee clips and slide over the pipe and loosely tighten the clip to the pipe, allowing room to push the top clamp under.



Fig. 15

Ensure that the head unit is fitted uppermost (on top of the pipe), no greater than a 45° angle. Tighten clips into position.



Fig. 16

Caution: If fitted to a hot pipe, recheck that the clamp is tight after 15 minutes.

4.2.3 Fitting the STAPS head to the STS17 or STS17.2

Separate the 'U' bolt from the top clamp. Slide the 'U' bolt around the Universal Flange on the STS17.2 casting and place the top clamp such that the STAPS sensor is upright and in contact with the top of the universal flange.



Fig. 17

Secure the top clamp to the 'U' bolt by tightening the wing nuts.

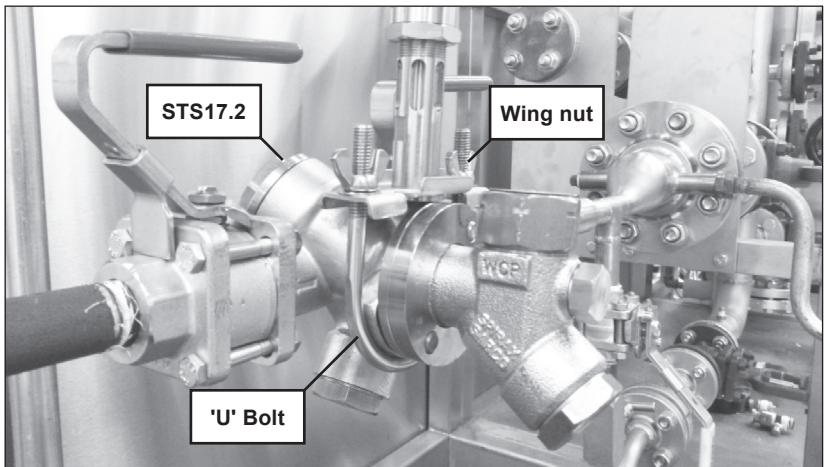

Fig. 18

4.3 Fitting the head remote from the sensor

In some circumstances it may be necessary to mount the head away from the sensor. This may be for temperature (head limited to an ambient temperature of 70°C), signal or space restrictions.

- 4.3.1** There are two options available for remote mounting. The standard head unit comes with 1 m of cable between the sensor and the head itself. The head is secured to the sensor with a 'U' bolt and two wing nuts.

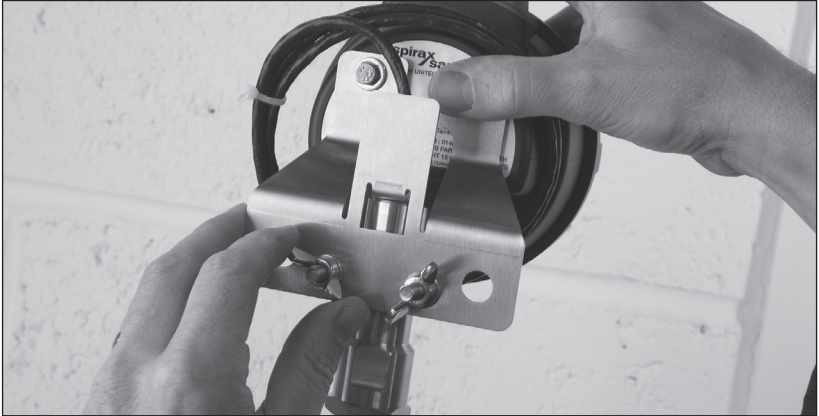

Fig. 19

By undoing the wing nuts, the head can be removed from the sensor and re-clamped / attached to another structure in a more convenient place, up to 1 m away. If the 'U' bolt is not suitable, the head can be secured using zip ties (not supplied).

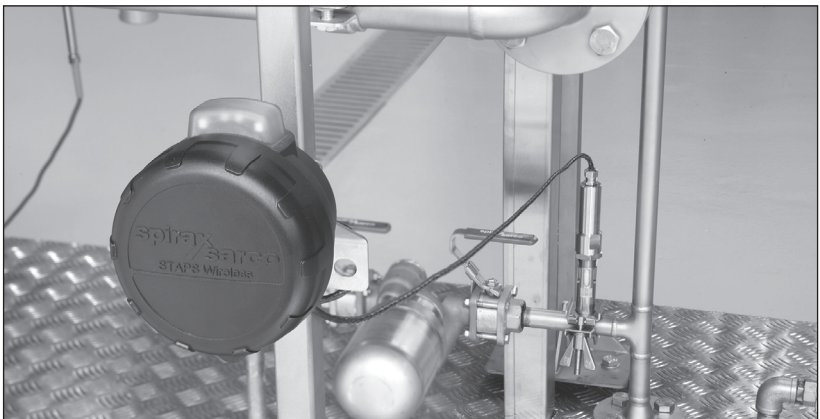
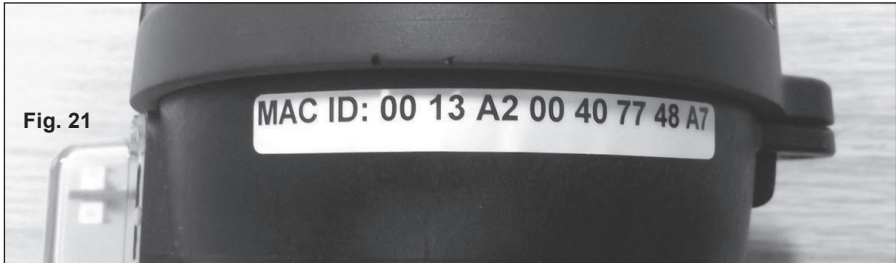

Fig. 20

Do not attach the head directly to the steam pipe or any other hot structure.
Do not lag the STAPS head unit, including the clamp and stem.

4.4 MAC address and PAN-ID

The MAC address is a unique number to the piece of equipment it is attached to. This cannot be changed and will remain with the product for its lifetime.



Important: Make sure that **MAC ID** is noted against a trap type and reference location. This data will be required for entry into the STAPS software - See Software copyright statement below.

Information required:

1. Location reference / trap tag No.
2. Type of trap.
3. Size of trap orifice.
4. Steam line pressure at the trap / head is fitted to.

Software copyright

Certain computer programs contained in this product [or device] were developed by Spirax-Sarco Limited ('the Work(s)').

Copyright © Spirax-Sarco Limited 2015

All Rights Reserved

Spirax-Sarco Limited grants the legal user of this product (or device) the right to use the Work(s) solely within the scope of the legitimate operation of the product (or device). No other right is granted under this licence. In particular and without prejudice to the generality of the foregoing, the Work(s) may not be used, sold, licensed, transferred, copied or reproduced in whole or in part or in any manner or form other than as expressly granted here without the prior written consent of Spirax-Sarco Limited.

5. Spare parts

Only the parts listed below are available for the STAPS system. No other parts are supplied as spares.

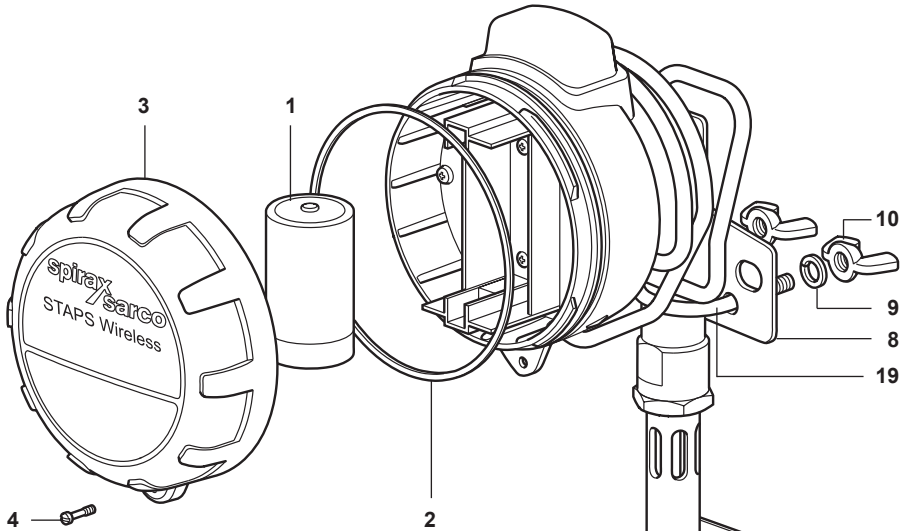

Fig. 22

Available spares

Battery (SAFT LS 33600 3.6 V battery)	1
'O' ring spares kit	2
Head mounting bracket, 'U' bolt and wing nuts	8, 9, 10 and 19
Clamp	5, 6 and 7
'U' bolt and wing nuts for an STS17 or STS17.2	20, 21 and 22
Front cover spares kit	3 and 4

How to order spares

Always order spare parts by using the description given in the column headed 'Available spares' and state the size and unit nomenclature that they are intended for.

Example:

1 off Battery spares kit (SAFT LS 33600 3.6 V battery) for a STAPS wireless steam trap monitoring system.

or

1 off Clamp for use with an STS17.2 pipeline trapping station.

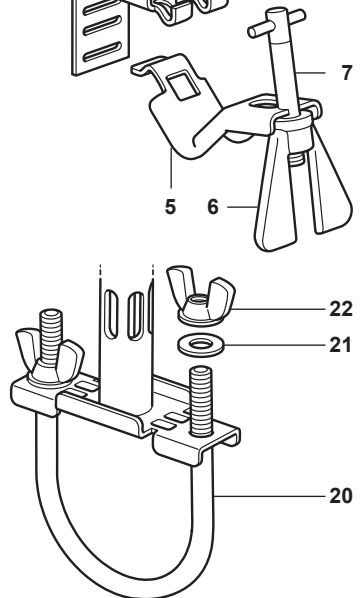

6. Certification and approvals

United States - Standards used for Certification:

FM3600, FM3610, FM3810, ASME / ISA 60079-0 and ASME / ISA 60079-11

Canada Standards used for Certification:

CSA 1010.1, CSA C22.2 No.157, CSA C22.2 No.25,
CAN / CSAE 60079-0 and CAN / CSA 60079-11

Note:

The above approvals are only valid if the product is installed using the genuine supplied component parts and accessories, including consumable items such as batteries and power leads.

7. Technical data

Head unit: See Section 3 for mounting options.

Integral battery	Lithium Thionyl Chloride
Maximum altitude	3 000 m (0.7 bar atmospheric)
Ambient temperature range	-29 to +70°C
Maximum pipe temperature	425°C
Maximum relative humidity	95% Enclosure rating IP66
Output	IEE 802-15 2.4 GHz
Visual indicators	LED

8. Technical glossary

Head

An individual trap sensing device which is networkable.

Intelligent Head

A normal head unit which has received additional configuration in order for it to act as a repeater device. The head will wake up and perform the normal trap analysis functions and then it will arbitrate to offer a re-transmission service for any other heads which are on the network but not directly in range of a receiver or repeater.

LAN - Local Area Network

A Local Area Network is a logical group of interconnected devices in a limited geographical area such as a home, school, factory, or office building.

MAC Address - Media Access Control

A media access control address is a unique number (in the form of six groups of two hexadecimal digits) that is assigned to a networkable device at the time of manufacture. As the number is unique it can be used to identify and address particular members of a network.

Network Administrator / IT Administrator (IT Admin)

The network administrator is an individual that is responsible for the maintenance and monitoring of computer hardware, software systems and related equipment that make up a computer network. This individual should be able to supply the required advice and details to install the STAPS system onto your companies network.

Orifice Size

The orifice size is the size of the hole in the trap seat that the condensate passes through.

PAN – Personal Area Network

A collection of co-operative devices sharing a similar geographical location and having a common PAN-ID.

PAN-ID - Personal area network identification

A PAN-ID is a number allocated to a network co-ordinator (receiver). Heads will base a decision on which network to join based on their PAN-ID. The default PAN-ID is zero which means that the device will join any network and then assume the PAN-ID of that network. A device with a non-zero PAN-ID allocated by the user will only join a network that has the same non-zero PAN-ID.

Receiver

A receiver is a physical device that creates and manages a PAN. It also functions as a gateway between the PAN and the Ethernet network.

Repeater

A repeater is a physical device not attached to the Ethernet network but forming part of a PAN. The function of the repeater is to extend the range of the network, where mains power is available.

RJ45 - Registered Jack 45

RJ45 plugs and sockets along with cat5e cable are used to connect devices together to form a network. Sometimes called an 8P8C connector. Commonly used on standard LAN interconnections

STAPS

Spirax Total Acoustic Performance Solutions.