

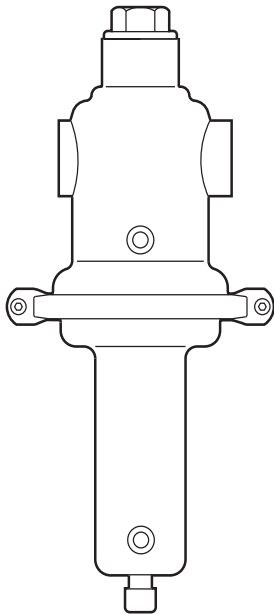

**SRV461S and SRV463S,
SRV461S Food+ and SRV463S Food+
Direct Acting Pressure Reducing Valves**
Installation and Maintenance Instructions



1. Safety information
2. General product information
3. Installation
4. Start-up and adjustment
5. Maintenance
6. Spare parts

1. Safety information

Safe operation of the unit can only be guaranteed if it is properly installed, commissioned and maintained by a qualified person (see Section 1.11) in compliance with the operating instructions. General installation and safety instructions for pipeline and plant construction, as well as the proper use of tools and safety equipment must also be complied with.

1.1 Intended use

Referring to these Installation and Maintenance Instructions, Name-plate and Technical Information Sheet, check that the product is suitable for the intended use/application.

The requirements of the EU Pressure Equipment Directive/UK Pressure Equipment (Safety) Regulations have been satisfied and, if applicable, the product accordingly bears the  mark:

- i) The product has been specifically designed for use on the fluids specified in the Technical Information Sheets. (These fluids are in Group 2 of the above mentioned Pressure Equipment Directive).
- ii) Check material suitability, pressure and temperature and their maximum and minimum values. If the maximum operating limits of the product are lower than those of the system in which it is being fitted, or if malfunction of the product could result in a dangerous overpressure or overtemperature occurrence, ensure a safety device is included in the system to prevent such over-limit situations.
- iii) Determine the correct installation situation and direction of fluid flow.
- iv) Spirax Sarco products are not intended to withstand external stresses that may be induced by any system to which they are fitted. It is the responsibility of the installer to consider these stresses and take adequate precautions to minimise them.
- v) Remove protective covers from all connections and protective film from all name-plates, where appropriate, before installation on steam or other high temperature applications.

1.2 Access

Ensure safe access and if necessary a safe working platform before attempting to work on the product. Arrange suitable lifting gear if required.

1.3 Lighting

Ensure adequate lighting, particularly where detailed or intricate work is required.

1.4 Hazardous liquids or gases in the pipeline

Consider what is in the pipeline or what may have been in the pipeline at some previous time. Consider; flammable materials, substances hazardous to health, extremes of temperature.

1.5 Hazardous environment around the product

Consider; explosion risk areas, lack of oxygen (e.g. tanks, pits), dangerous gases, extremes of temperature, hot surfaces, fire hazard (e.g. during welding), excessive noise, moving machinery.

1.6 The system

Consider the effect on the complete system of the work proposed. Will any proposed action (e.g. closing isolation valves, electrical isolation) put any other part of the system or any personnel at risk?

Dangers might include isolation of vents or protective devices or the rendering ineffective of controls or alarms. Ensure isolation valves are turned on and off in a gradual way to avoid system shocks.

1.7 Pressure systems

Ensure that any pressure is isolated and safely vented to atmospheric pressure. Consider double isolation (double block and bleed) and the locking or labelling of closed valves. Do not assume that the system has depressurised even when the pressure gauge indicates zero.

1.8 Temperature

Allow time for temperature to normalise after isolation to avoid danger of burns.

1.9 Tools and consumables

Before starting work ensure that you have suitable tools and/or consumables available. Use only genuine Spirax Sarco replacement parts.

1.10 Protective clothing

Consider whether any protective clothing is required by yourself and/or others in the vicinity to protect against the hazards of, for example, chemicals, high/low temperature, noise, falling objects, and dangers to eyes and face.

1.11 Permits to work

All work must be carried out or be supervised by a suitably competent person.

Installation and operating personnel should be trained in the correct use of the product according to these instructions.

Where a formal 'permit to work' system is in force it must be complied with. Where there is no such system, it is recommended that a responsible person should know what work is going on and, where necessary, arrange to have an assistant whose primary responsibility is safety.

Post 'warning notices' if necessary.

1.12 Handling

Manual handling of Spirax-Sarco products may present a risk of injury. Lifting, pushing, pulling, carrying or supporting a load by bodily force can cause injury particularly to the back. You are advised to assess the risks taking into account the task, the individual, the load and the working environment and use the appropriate handling method depending on the circumstances of the work being done.

1.13 Residual hazards

In normal use the external surface of the product may be very hot. If used at the maximum permitted operating conditions the surface temperature of some products may reach temperatures in excess of 190 °C (374 °F).

Many products are not self-draining. Take due care when dismantling or removing the product from an installation (refer to 'Maintenance instructions').

1.14 Freezing

Provision must be made to protect products which are not self-draining against frost damage if they are inoperative in environments where they may be exposed to temperatures below freezing point.

1.15 Specific product safety information

Do not attempt to dismantle the valve without first releasing the compression on the control spring.

For valves containing a Viton/FPM elastomer seal

If the valve has been subjected to a temperature approaching 315 °C (599 °F), the Viton/FPM may have decomposed and formed hydrofluoric acid. Avoid skin contact and inhalation of any dust or fumes as this acid causes deep burns and damage to the respiratory system.

PTFE components

Within its working temperature range PTFE is a completely inert material, but when heated to its sintering temperature it gives rise to gaseous decomposition products or fumes which can produce unpleasant side effects if inhaled. Smoking should be prohibited in workshops where PTFE is handled because tobacco contaminated with PTFE will give rise to polymer fumes when burnt. It is therefore important to avoid contamination of clothing, especially the pockets, with PTFE and to maintain a reasonable standard of cleanliness by washing hands and removing PTFE particles lodged under the fingernails.

1.16 Disposal

This product is recyclable and no ecological hazard is anticipated with its disposal providing due care is taken, EXCEPT:

EPDM/FEPM elastomer seal:

- Waste parts can be landfilled, when in compliance with National and Local regulations.
- Waste parts can be incinerated, but a scrubber must be used to remove Hydrogen Fluoride, which is evolved from the product and with compliance to National and Local regulations.
- Is insoluble in aquatic media.

PTFE components:

- Can only be disposed of by approved methods, not incineration.
- Keep PTFE waste in a separate container, do not mix it with other rubbish.

Please visit the Spirax Sarco product compliance web pages

<https://www.spiraxsarco.com/product-compliance>

for up to date information on any substances of concern that may be contained within this product. Where no additional information is provided on the Spirax Sarco product compliance web page, this product may be safely recycled and/or disposed providing due care is taken. Always check your local recycling and disposal regulations.

1.17 Returning products

Customers and stockists are reminded that under UK and EC Health, Safety and Environment Law, when returning products to Spirax Sarco they must provide information on any hazards and the precautions to be taken due to contamination residues or mechanical damage which may present a health, safety or environmental risk. This information must be provided in writing including Health and safety data sheets relating to any substances identified as hazardous.

2. General product information

2.1 General description

Types SRV461S and SRV463S are direct acting pressure reducing valves with all wetted parts in AISI 316L/1.4404, 1.4408, 1.4462 and 1.4571 stainless steel for steam, liquid or gas applications. The standard valve has a soft seal in Fluoraz (FEPM).

SRV461S and SRV463S can be provided for Food+ application, please advise when ordering the product.

How they work

The normal position before start-up is with the valve head (5) in the open position as a result of the force transmitted by the control spring (12). As steam or other operating fluid passes through the valve, the pressure downstream of the valve increases and is transmitted through the pressure sensing pipe connection (not shown) to the upper side of the diaphragm (6), thus opposing the spring force. When the downstream pressure is at the set pressure, the forces generated by the spring and the fluid on the diaphragm are in equilibrium and the valve modulates to maintain control conditions. When the downstream pressure exceeds the set value, the forces are not balanced and the valve closes. Similarly, when the downstream pressure is below set pressure, the valve will open.

Typical applications include:

- Clean steam.
- Gas and liquid supplies to centrifuges.
- Freeze dryers.
- Sterilisers.
- Autoclaves.
- Process tanks.
- Humidifiers.
- Culinary equipment.

2.2 Sizes and pipe connections

Type SRV461S

½", ¾", 1", 1¼", 1½" and 2"

Screwed NPT or BSP

Type SRV463S

DN15, DN20, DN25, DN32, DN40 and DN50

Flanged EN1759-1 Class 150, Class 300 and EN1092-1 PN40

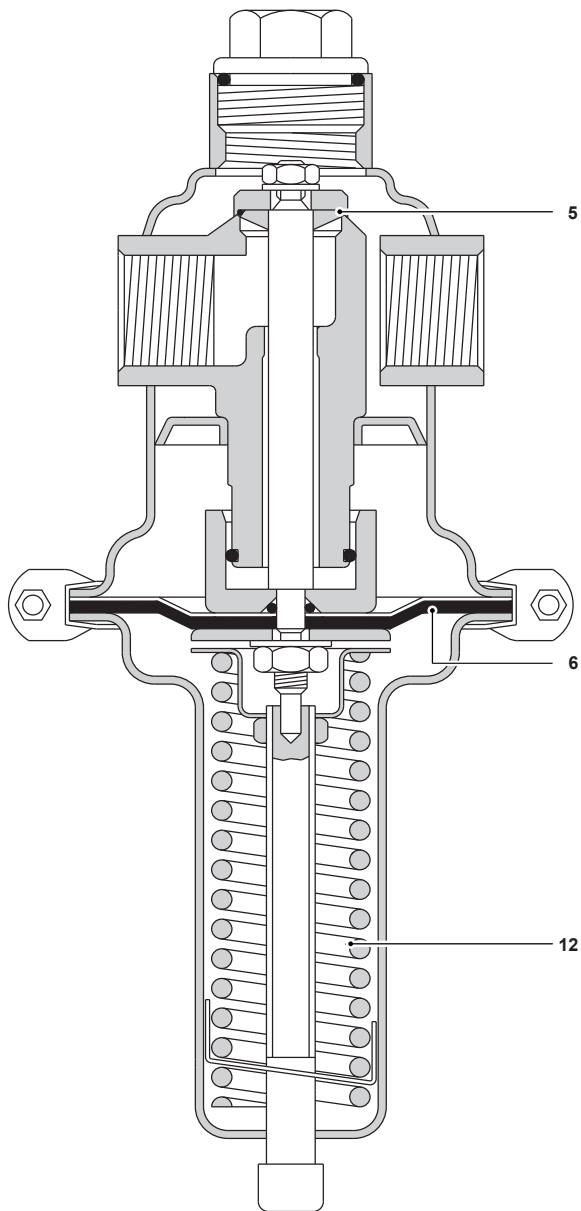
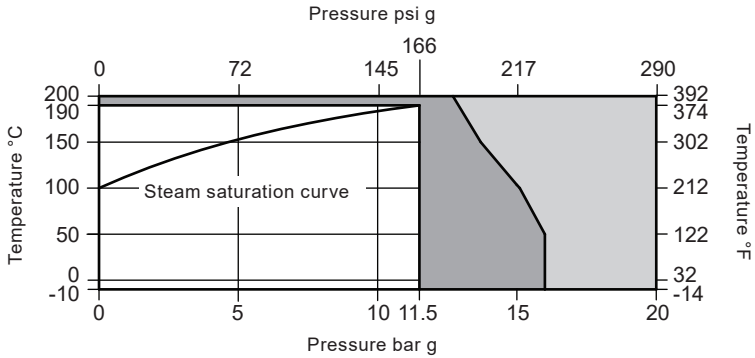

Fig. 2

2.3 Pressure/temperature limits - Flanged (Class 150)

Class 150 flanges

For use on steam



Class 150 flanges

For use on liquids and gases

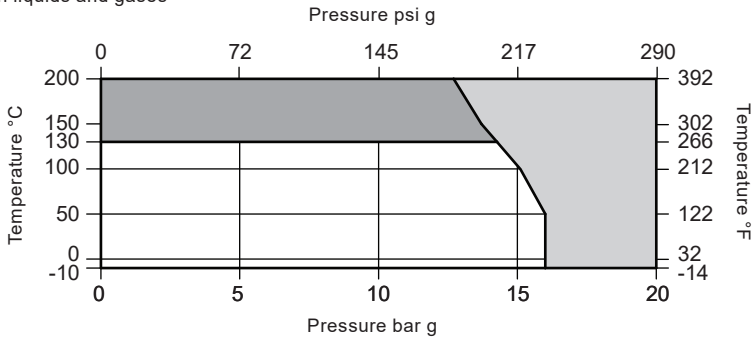

- The product **must not** be used in this region.
- The product should not be used in this region or beyond its operating range as damage to the internals may occur.

Body design conditions	Flanged Class 150		PN16
Maximum allowable pressure	Flanged Class 150		16 bar g @ 50 °C (232 psi g @ 122 °F)
Maximum allowable temperature	Flanged Class 150		200 °C @ 12.7 bar g (392 °F @ 184 psi g)
Minimum allowable temperature			-10 °C (14 °F)
Maximum operating temperature	Flanged Class 150	Steam (Saturated)	190 °C @ 11.5 bar g (374 °F @ 167 psi g)
		Other Liquids & Gases	50 °C @ 16 bar g (122 °F @ 232 psi)
Maximum operating Pressure	Flanged Class 150	Steam (Saturated)	11.5 bar g @ 190 °C (167 psi g @ 374 °F)
		Other Liquids and Gases	16 bar g @ 50 °C (232 psi g @ 122 °F)
Minimum operating temperature			-10 °C (14 °F)
Maximum differential pressure (see section 2.7)			
Designed for a maximum cold hydraulic test pressure of:	Flanged Class 150		24 bar g (348 psi g)

2.4 Pressure/temperature limits - Screwed and Flanged (PN40 and Class 300)

Screwed connections
PN40 flanges
Class 300 flanges

For use on steam

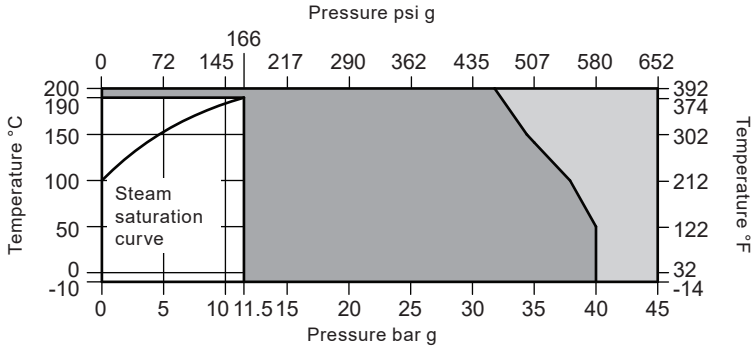

Screwed connections
PN40 flanges
Class 300 flanges

For use on liquids and gases

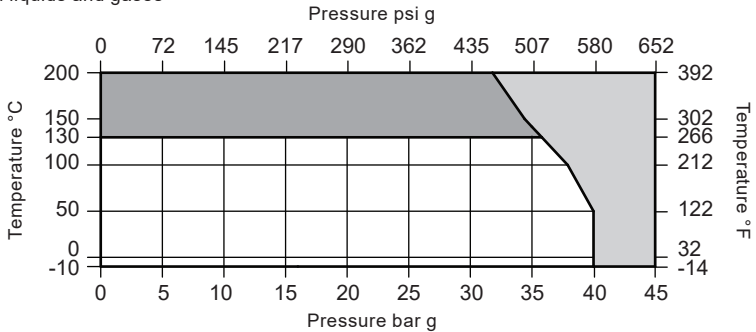

 The product **must not** be used in this region.

 The product should not be used in this region or beyond its operating range as damage to the internals may occur.

Body design conditions	Screwed, Flanged PN40 and Class 300		PN40
Maximum allowable pressure	Screwed, Flanged PN40 and Class 300		40 bar g @ 50 °C (580 psi g @ 122 °F)
Maximum allowable temperature	Screwed, Flanged PN40 and Class 300		200 °C @ 31.8 bar g (392 °F @ 461 psi g)
Minimum allowable temperature			-10 °C (14 °F)
Maximum operating temperature	Screwed, Flanged PN40 and Class 300	Steam (Saturated)	190 °C @ 11.5 bar g (374 °F @ 167 psi g)
		Other Liquids and Gases	50 °C @ 40 bar g (122 °F @ 580 psi g)
Maximum operating Pressure	Screwed, Flanged PN40 and Class 300	Steam (Saturated)	11.5 bar g @ 190 °C (167 psi g @ 374 °F)
		Other Liquids and Gases	40 bar g @ 50 °C (580 psi g @ 122 °F)
Minimum operating temperature			-10 °C (14 °F)
Maximum differential pressure (see section 2.7)			
Designed for a maximum cold hydraulic test pressure of:	Screwed, Flanged PN40 and Class 300		60 bar g (870 psi g)

2.5 Pressure ranges

The SRV461S and SRV463S are available for use within the downstream pressure ranges shown below.

0.02 - 0.12 bar g	(0.29 - 1.74 psi g)
0.10 - 0.50 bar g	(1.45 - 7.25 psi g)
0.30 - 1.10 bar g	(4.35 - 15.95 psi g)
0.80 - 2.50 bar g	(11.60 - 36.25 psi g)
2.00 - 5.00 bar g	(29.00 - 72.50 psi g)
4.00 - 8.00 bar g	(58.00 - 116.00 psi g)
6.00 - 12.00 bar g	(87.00 - 174.00 psi g)

2.6 Kv values

Valve size	½" DN15	¾" DN20	1" DN25	1¼" DN32	1½" DN40	2" DN50
Kv at 20% offset	4.0	5.6	6.4	17.6	17.6	17.6
Maximum Kv	5.0	7.0	8.0	22.0	22.0	22.0

To maximise the control accuracy (especially for large load variations) use the Kv values given at 20% offset. For safety valve sizing use the maximum Kv values. Leakage rate ≤ 0.05% of the maximum Kv value.

2.7 Permissible reduction ratio (maximum P_1/P_2)

Setting range (bar g)	Nominal diameter	
	½" - 1" DN15 - DN25	1¼" - 2" DN32 - DN50
0.02 - 0.12	80:1	50:1
0.10 - 0.50	40:1	25:1
0.30 - 1.10	30:1	18:1
0.80 - 12.00	20:1	12:1

2.8 Dimensions (approximate) in millimetres

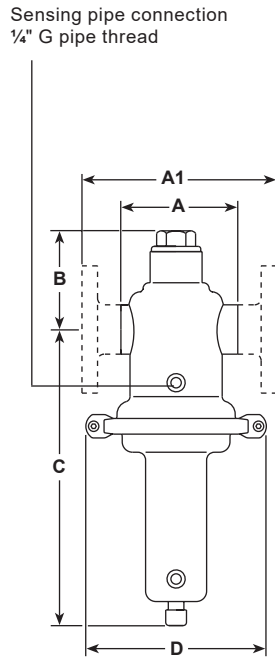
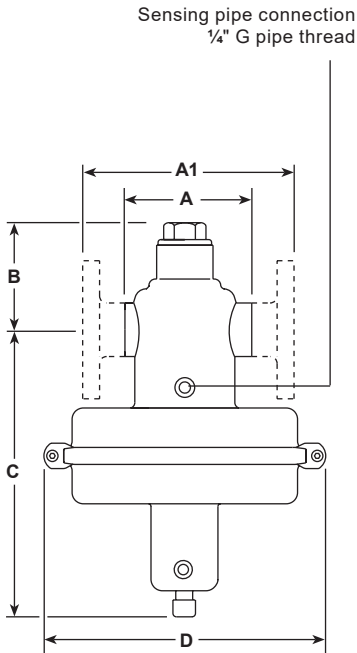

Size	All pressure ranges			Pressure range (bar)				Pressure range (bar)					
				0.02 - 0.12		0.1 - 0.5		0.3 - 1.1		0.8 - 2.5 and 2 - 5		4 - 8 and 8 - 12	
	A	A1	B	C	ØD	C	ØD	C	ØD	C	ØD	C	ØD
DN15 1/2"	85	130	76	300	360	300	264	300	200	235	138	235	138
DN20 3/4"	91	150	76	300	360	300	264	300	200	235	138	235	138
DN25 1"	85	160	76	300	360	300	264	300	200	235	138	235	138
DN32 1 1/4"	130	180	80	300	360	300	264	300	200	235	138	235	138
DN40 1 1/2"	145	200	80	300	360	300	264	300	200	235	138	235	138
DN50 2"	185	230	80	300	360	300	264	300	200	235	138	235	138

SRV461S and SRV463S, SRV461S Food+ and SRV463S Food+ Direct Acting Pressure Reducing Valves

2.8 Weights (approximate) in kg

Sensing pipe connection
1/4" G pipe thread

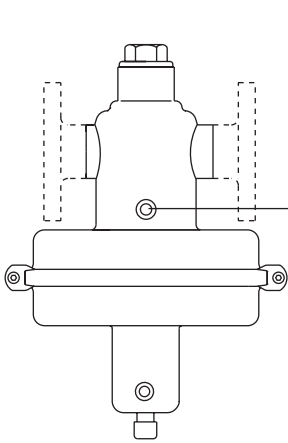

Sensing pipe connection
1/4" G pipe thread

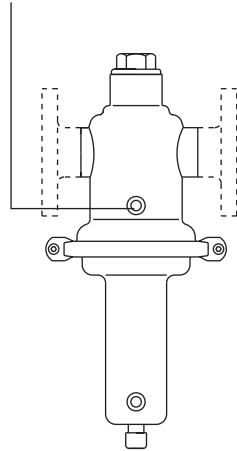

Set Pressure Range (bar)		0.02 - 0.12	0.1 - 0.5	0.3 - 1.1	0.8 - 12
1/2" - 1"	Screwed	13.5	7.1	6.1	3.1
DN15 - DN25	Flanged	15.3	8.9	7.9	4.9
1 1/4" - 2"	Screwed	14.4	8.0	7.0	4.0
DN32 - DN50	Flanged	18.4	12.0	11.0	8.0

3. Installation

3.1 General

Check that the SRV supplied is fitted with a spring suitable for your pressure requirements.

The SRV pressure reducing valve should always be fitted in a horizontal pipeline with the adjustment head below the valve for steam service.

Isolating valves should be fitted giving a clear run of 10 pipe diameters on either side of the reducing valve. It is important that the line stresses such as can be caused by expansion or inadequate supporting of the pipe are not imposed on the valve body.

The piping on both upstream and downstream sides of the valve must be of ample size to avoid undue pressure drop in the pipeline and any reduction in line size should be made using eccentric reducers.

It is advisable to protect the valve by fitting a strainer on the upstream side. By fitting the strainer on its side you will prevent the body filling with water that would reduce the screening area.

When the SRV is used on steam, the pipeline should be drained on the upstream side using an adequate drain pocket, or separator if steam supply is known to be wet, and a Spirax Sarco trap. A pressure gauge is essential on the downstream side and is recommended on the upstream side as well.

If required, a suitable sized safety valve should be fitted, to protect downstream plant and piping systems and components.

All pressure reducing valve station ancillary items are available from Spirax Sarco. For installations where equipment downstream can be closed off then a further downstream trap set is required.

Food+ variants only

This product is intended to be connected into a system that can operate an EC1935 compliant process.

To minimise the risk of non-intentionally added substances in the system, it is essential that an appropriate CIP (cleaning in place) cycle is carried out by the end user prior to first use in a food contact application.

A list of the materials that could come directly or indirectly into contact with foodstuffs can be found in the Declaration of Conformity available for this product.

3.2 Recommended installation

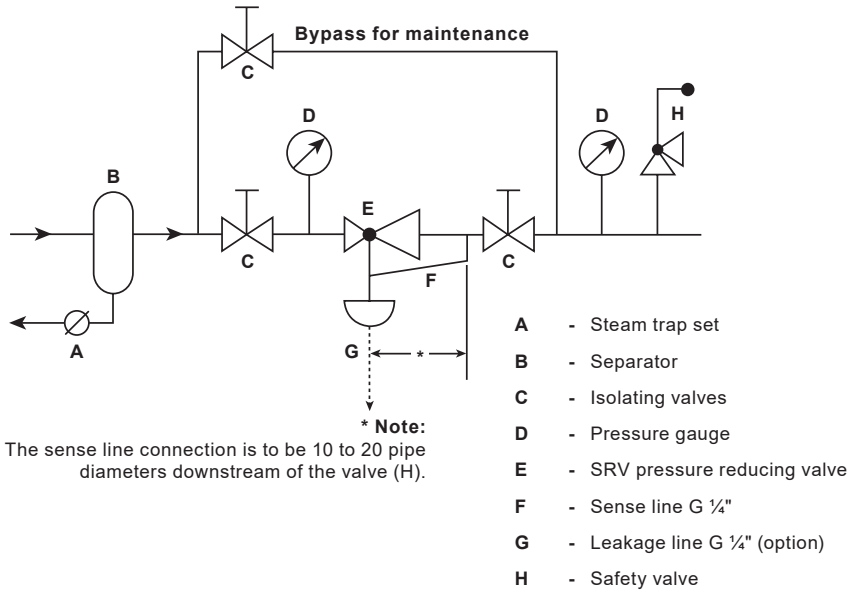

Fig. 3

3.3 Pressure sensing pipe

1. A 1/4" sensing line with suitable compression fittings should be used. Where downstream pressure is less than 0.1 bar (1.45 psi) install a damping pot in the sensing line.
2. On steam service, the sensing line should be pitched upwards i.e. with the adjustment knob of the pressure reducing valve below the steam pipework. This is in order for condensate to run back into the diaphragm chamber.
3. Connect the sensing line to a straight portion of the pipework at least 15 pipe diameters after the reducing valve and a minimum of 10 pipe diameters after the nearest fitting (tee, valve etc.)
4. For ease of servicing an isolating valve should be incorporated into the sensing line. This can be closed when the pressure reducing valve requires maintenance.

4. Start-up and adjustment

1. First make certain that all isolating valves are closed.
2. Check that the spring is slack. If necessary turn the adjustment anticlockwise to release tension.
3. Open isolating valves in the following order:
 - a) Open the isolating valve ahead of the steam trap on the steam supply line. This will ensure water free steam at the regular inlet when put into operation.
 - b) Open the isolating valve on the pressure sensing line.
 - c) Open the downstream isolating valve.
 - d) Caution: Open the inlet stop valve slowly to avoid damage from waterhammer.
4. Slowly turn the adjustment head clockwise until the reduced pressure required is indicated on the pressure gauge downstream of the valve.
5. Once the system has stabilised itself, it may be necessary to make readjustment.

5. Maintenance

Note: Read Section 1, 'Safety information' before any maintenance work is actioned.

5.1 General inspection

While a programme of planned maintenance is always recommended, the Spirax Sarco SRV461S and SRV463S valve will give long and trouble free service if correctly selected, installed and kept reasonably free of dirt and foreign matter. Dirt and foreign matter are most likely to collect during installation and later trouble can be avoided by inspecting the installation after a few days.

Check the following:-

1. Clean all pipeline fittings or strainers. (Remove elements or screens to clean).
2. Check all joints for leakage.

5.2 Inspecting/replacing diaphragm and 'O' ring seal

(Refer to Figure 4 and Figure 5)

1. Shut the isolating valves upstream and downstream of the SRV pressure reducing valve.
2. Shut the isolating valve on the pressure sensing line.
3. Allow the pressure reducing valve to cool.
4. Release the tension on the spring by turning the adjustment screw fully anticlockwise.
5. Remove the spring housing by removing the securing V-band nuts and bolts and then the V-band.
6. Remove the cap from the top of the valve.
7. Remove the hexagon nut from the underside of the diaphragm and remove the diaphragm assembly. The diaphragm has a two layer construction with a protective PTFE layer facing the contained fluid. The diaphragm (6) and 'O' ring seals (7, 8, 9 and 16) should be inspected for signs of wear or damage and replaced if necessary. It is important to reassemble all components in reverse order as shown in the diagram overleaf ensuring the diaphragm is centrally located and free to move, and not in contact with any debris or sharp edges.
8. Pull out the valve spindle and head assembly through the top of the valve body and inspect the 'O' ring seat seal (6) for wear or damage, replace if necessary.
9. Reassemble in reverse order.
10. For Food+ installations, it is essential that an appropriate CIP (cleaning in place) cycle is carried out by the end user after maintenance.

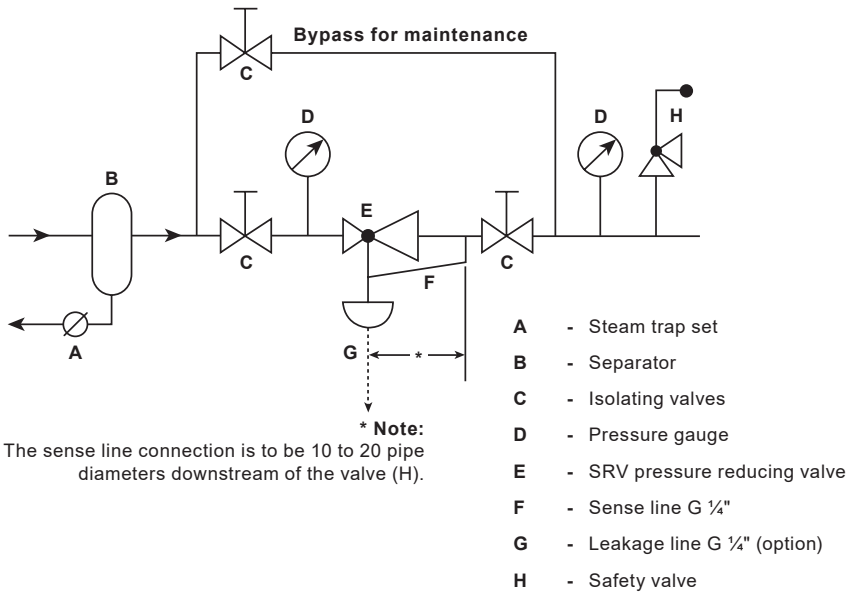

Fig. 4

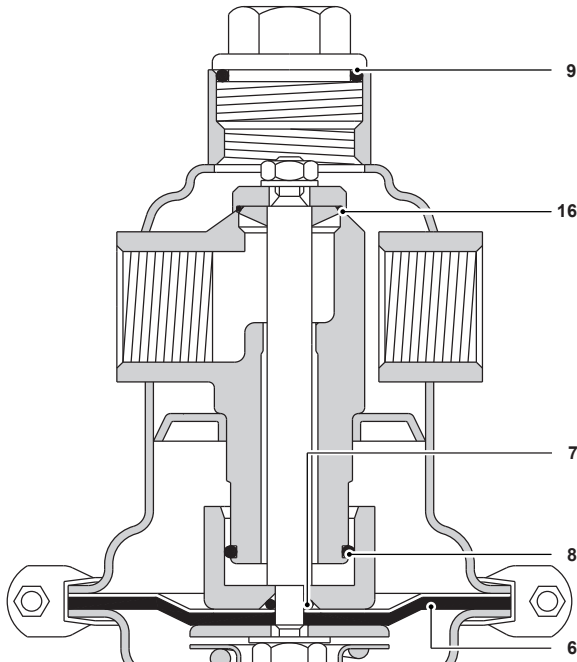

Fig. 5

6. Spare parts

The spare parts available are detailed below.
No other parts are supplied as spares.

Available spares

Diaphragm and 'O' ring **6, 7, 8, 9, 16**

How to order spares

Always order spares by using the description given in the column headed 'Available spares' and state the size, model, pressure range and indicate whether it is a standard or Food+ variant.

Example: 1 - Diaphragm and 'O' ring kit for a Spirax Sarco DN15 SRV463S pressure reducing valve with FEPM seat seal and having a pressure range of 0.8 to 2.5 bar for Food+.

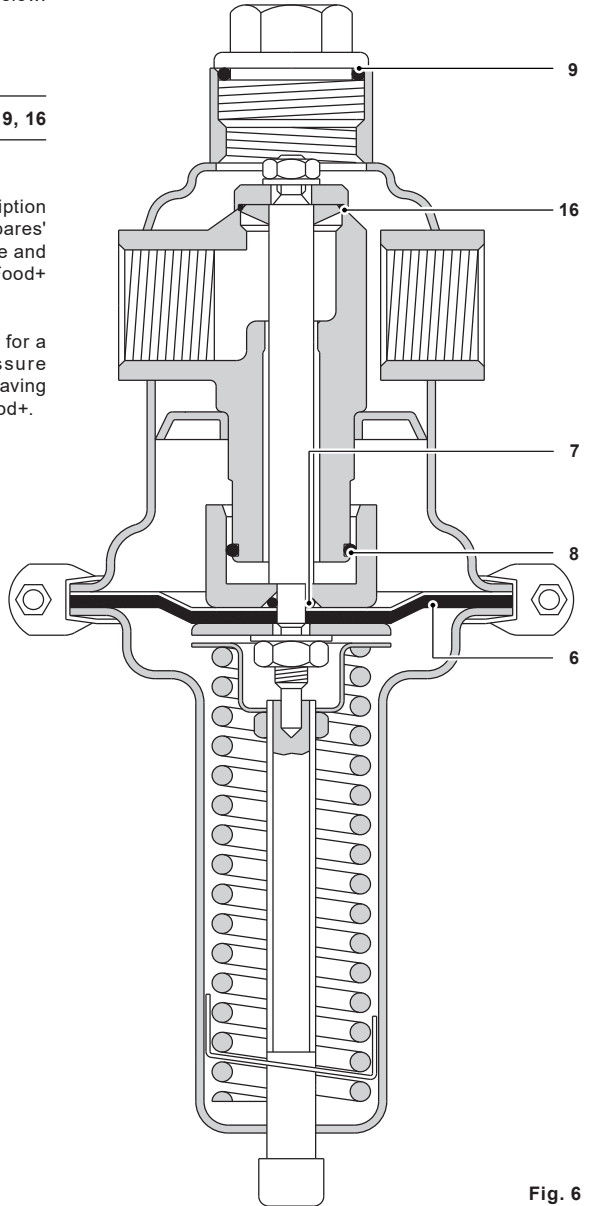

Fig. 6