

SP7-10, SP7-11, SP7-12 and SP7-20, SP7-21, SP7-22 Parameterization



Device firmware version 05: SP7-10 / SP7-20
Device firmware version 03: SP7-11 / SP7-12 / SP7-21 / SP7-22

Contents

1. General information

1.1 General information and instructions	4
1.2 Warnings	
1.3 Intended use	
1.4 Improper use	5
1.5 Warranty provisions	

2. Operation

2.1 Safety instructions	6
2.2 Parameterization of the device	
2.3 Description of symbols	
2.4 Operating button functions	7
2.5 Menu levels	
2.6 operating modes	8
2.7 Inhibiting operation	11

3. Configuration

3.1 General information	12
3.2 Example	
3.3 4.20mA and 4-20mA HART parameter descriptions (SP7-10 and SP7-20)	13
3.4 HART parameter overview (Graphic)	17
3.5 Parameter group 1: Standard	18
3.6 Parameter group 2: Setpoint	22
3.7 Parameter group 3: Operating range	26
3.8 Parameter group 4: Messages	28
3.9 Parameter group 5: Alarms	31
3.10 Parameter group 6: Manual adjustment	33
3.11 Parameter group 7: Control parameters	37
3.12 Parameter group 8: Analog output	44
3.13 Parameter group 9: digital output	47
3.14 Parameter group 10: digital input	49
3.15 Parameter group 11: Safe position	50
3.16 Profibus PA and Foundation Fieldbus parameter descriptions (SP7-11, SP7-12 and SP7-21, SP7-22) - PROFIBUS PA and Foundation Fieldbus parameter overview	53
3.17 Profibus PA and Foundation Fieldbus parameter descriptions (SP7-11, SP7-12 and SP7-21, SP7-22)	54
3.18 Specific parameters for digital BUS communication versions only: - P1.5 ADDRESS – Bus Address (PROFIBUS PA version only)	55
3.19 P7.4 GOPULSE [^] Go pulse (up)	
3.20 P7.5 GOPULSE ^v Go pulse (down)	56

4. Diagnosis / error messages

4.1a Error codes	57
4.1b Specific SP7-11/12 and SP7-21/22 Error messages	59
4.2 Alarm codes	60
4.3 Message codes	61
4.4 Error handling	62

Copyright © Spirax-Sarco Limited 2022

All rights reserved

Spirax-Sarco Limited grants the legal user of this product (or device) the right to use the Work(s) solely within the scope of the legitimate operation of the product (or device). No other right is granted under this licence. In particular and without prejudice to the generality of the foregoing, the Work(s) may not be used, sold, licensed, transferred, copied or reproduced in whole or in part or in any manner or form other than as expressly granted here without the prior written consent of Spirax-Sarco Limited.

1. General information

1.1 General information and instructions

These instructions are an important part of the product and must be retained for future reference. Installation, commissioning, and maintenance of the product may only be performed by trained specialist personnel who have been authorized by the plant operator accordingly. The specialist personnel must have read and understood the manual and must comply with its instructions. For additional information or if specific problems occur that are not discussed in these instructions, contact the manufacturer. The content of these instructions is neither part of nor an amendment to any previous or existing agreement, promise or legal relationship. Modifications and repairs to the product may only be performed if expressly permitted by these instructions. Information and symbols on the product must be observed. These may not be removed and must be fully legible at all times. The operating company must strictly observe the applicable national regulations relating to the installation, function testing, repair and maintenance of electrical products.

1.2 Warnings

The warnings in these instructions are structured as follows:

DANGER	
	The signal word "DANGER" indicates an imminent danger. Failure to observe this information will result in death or severe injury

WARNING	
	The signal word "WARNING" indicates an imminent danger. Failure to observe this information may result in death or severe injury.

CAUTION	
	The signal word "CAUTION" indicates an imminent danger. Failure to observe this information may result in minor or moderate injury.

NOTE	
	The signal word "NOTE" indicates useful or important information about the product. The signal word "NOTE" is not a signal word indicating a danger to personnel. The signal word "NOTE" can also refer to material damage.

1.3 Intended use

Positioning of pneumatically controlled actuators; designed for mounting on linear and part-turn actuators. The device is designed for use exclusively within the stated values on the nameplate and in the data sheet.

- The maximum operating temperature must not be exceeded.
- The permissible ambient temperature must not be exceeded.
- The housing protection type must be observed.

1.4 Improper use

The following are considered to be instances of improper use of the device:

- For use as a climbing aid, e.g. for mounting purposes
- For use as a support for external loads, e.g. as a support for piping, etc.
- Material application, e.g. by painting over the name plate or welding/soldering on parts.
- Material removal, e.g. by spot drilling the housing.

1.5 Warranty provisions

Using the device in a manner that does not fall within the scope of its intended use, disregarding this manual, using underqualified personnel, or making unauthorized alterations releases the manufacturer from liability for any resulting damage. This renders the manufacturer's warranty null and void.

2. Operation

2.1 Safety instructions

CAUTION	
	<p>Risk of injury due to incorrect parameter values!</p> <p>Incorrect parameter values can cause the valve to move unexpectedly. This can lead to process failures and result in injuries</p> <ul style="list-style-type: none">- Before recommissioning a positioner that was previously in use at another location , always reset the device to its factory settings.- Never start Auto Adjust before restoring the factory settings

If there is a chance that safe operation is no longer possible, take the device out of operation and secure it against unintended startup.

2.2 Parameterization of the device

The LCD display features operating buttons which enable the device to be operated with the housing cover open.

2.2.1 Menu navigation

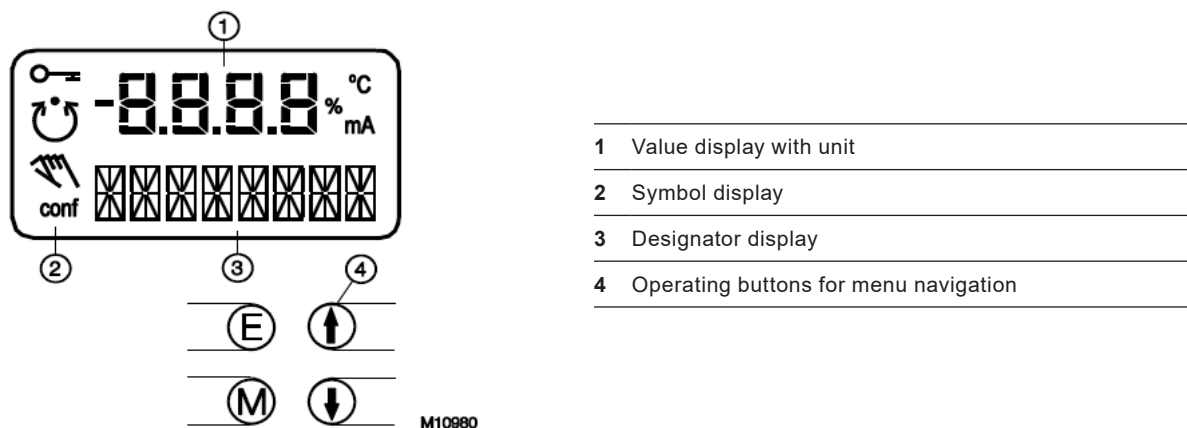

Fig. 1: LCD display with operating buttons



Value display with unit

This 7-segment display with four digits indicates parameter values or parameter reference numbers. For values, the physical unit (°C, %, mA) is also displayed.

Designator display



This 14-segment display with eight digits indicates the designators of the parameters with their status, of the parameter groups, and of the operating modes.

2.3 Description of symbols

Symbol	Description
	Operation or access is restricted.
	Control loop is active. The symbol is displayed when the positioner is in operating mode 1.0 CTRL_ADP (adaptive control) or 1.1 CTRL_FIX (fixed control) at operating level. On the configuration level there are test functions for which the controller will be active as well. The control loop symbol will also be displayed when these functions are active.
	Manual adjustment. The symbol is displayed when the positioner is in operating mode 1.2 MANUAL (manual adjustment within the stroke range) or 1.3 MAN_SENS (manual adjustment within the measuring range) at operating level. At configuration level, manual adjustment is active when setting the valve range limits (parameter group 6 MIN_VR (min. of valve range) and 6 MAX_VR (max. of valve range)). The symbol will also be displayed when these parameters are being set.
conf	The configuration icon indicates that the positioner is at the configuration level. The control operation is inactive.

The four operating buttons ENTER, MODE, ARROW UP and ARROW DOWN are pressed individually or in certain combinations according to the function desired.

2.4 Operating button functions

Control button	Meaning
ENTER 'E'	-Acknowledge message -Start an action -Save in the non-volatile memory
MODE 'M'	-Choose an operating mode (Operating level) -Select parameter group (Configuration level)
	UP direction arrow
	DOWN direction arrow
Press and hold all buttons for 5 seconds	Reset

2.5 Menu levels

The positioner has two operating levels:

Operating level	On the operating level the positioner operates in one of four possible operating modes (two for automatic control and two for manual mode). Parameters cannot be changed or saved on this level.
Configuration level	On this level most of the parameters of the positioner can be changed locally. The PC is required to change the limit values for the movement counter, the travel counter, and the user-defined characteristic curve. On the configuration level the active operating mode is deactivated. The I/P module is in neutral position. The control operation is inactive.

NOTE



Property damage

During external configuration via a PC, the positioner no longer responds to the setpoint current. This may lead to process failures. Prior to external configuration, always move the actuator to the safety position and activate manual adjustment.

2.6 operating modes

2.6.1 Operating mode 1.0: Control with adaptation



Controlling operation with automatic adaptation of the control parameters When the P1.0CTRL_ADP positioner is operated in "Adaptive Mode", the control parameters are automatically optimized to the operating conditions in small increments. This is especially helpful if valves and fittings could not be operated with reference conditions while the Auto Adjust function was in progress. Since self-optimization in "Adaptive Mode" is subject to several factors during operation and mismatches could result over a longer period, we recommend that this operating mode only be activated over several hours and be followed by the mode P1.1 CTRL_FIX.



The valve position is indicated as a percentage of the operating range (from 0 ... 100%).

2.6.2 Operating mode 1.1: Control without adaptation



Controlling operation with fixed parameters This is the normal recommended operating mode.



In contrast to the operating mode P1.0 CTRL_ADP, the control parameters are not automatically adjusted. The valve position is indicated as a percentage of the operating range (from 0 ... 100%).

In both control modes 1.0 and 1.1, several values can be displayed besides the current actuator position:

Set point display



1. Press and hold the ARROW UP button. The setpoint is displayed.
2. Briefly press ENTER.

The setpoint display is toggled between the setpoint current at the input terminals in mA and the setpoint as a percentage of the stroke range.

Temperature display



1. Press and hold the ARROW DOWN button. The temperature inside the case is displayed.
2. Briefly press ENTER.
3. The temperature display is toggled between °C and °F.

Display of control deviation



1. Press and hold the ARROW UP and ARROW DOWN button.
- The control deviation is displayed as a percentage (%) of the stroke range.

2.6.3 Operating mode 1.2: Manual adjustment in the stroke range



The valve is adjusted manually using the direction buttons ARROW UP and ARROW DOWN within the stroke range.

1. Press and hold the button for the desired direction.
2. To activate the high speed mode in the manual mode, press the second arrow button.

CAUTION



If air escapes due to a leakage, the position will not be readjusted.
Configured stroke limit positions and stroke times are not effective in manual mode.



In this operating mode the valve position is indicated as a percentage (%) of the stroke range.

2.6.4 Operating mode 1.3: Manual adjustment in the sensor range

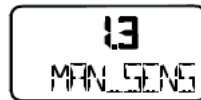

See operating mode 1.2



2.7 Inhibiting operation

Positioner operation can be inhibited completely or partially via the digital input and the FUNCTION parameter in parameter group 10 (DIG_IN (digital input)). This allows the user to prevent or restrict operating actions of unauthorized personnel as desired. When operation is disabled in this way, the key symbol is indicated in the display.

The following levels of configuration locks are possible:

Inhibiting the local configuration Local operation on the operating level and remote operation and configuration via a PC are still possible.

Inhibiting all local operating functions No local operating actions can be executed. Both the operating level and the configuration level are locked. Remote operation and setting of parameters via a PC is still possible.

Inhibiting local operation and remote configuration It is not possible to operate or configure the positioner locally or configure it using a PC.

NOTE



This inhibit function can only be deactivated when a voltage of 12 ... 30 V is applied at the digital input of the positioner (see Function selection in parameter group 10, on page 49).

3. Configuration

3.1 General information

Most parameters for the positioner can be set locally, meaning that configuration only needs to be performed via the local communication interface (LCI) or HART modem and PC in exceptional cases. You may also deny or restrict local modification and saving of parameters by completely or partially blocking access to the configuration level (see Chapter "Inhibiting operation" on page 8 and the description of the Function parameter on page 30). To simplify the process, the different parameters are grouped as follows:

ID	Designator	ID Designator Name
P1._	STANDARD	Standard
P2._	SETPOINT	Setpoint
P3._	ACTUATOR	Actuator
P4._	MESSAGES	Events
P5._	ALARMS	Alarms
P6._	MAN_ADJ	Manual adjustment
P7._	CTRL_PAR	Control parameters
P8._	ANLG_OUT	Analog output
P9._	DIG_OUT	Digital output
P10._	DIG_IN	Digital input
P11._	FS / IP	Factory setting, I/P type

The following sections provide an overview (in tabular and graphical format) of the overall structure of the parameter groups and parameters.

3.2 Example



Parameter (1st line in display)	Indicator (2nd line in display)	Function	Possible parameter settings	Unit	Factory Setting
P1 -	STANDARD				
P1.0	ACTUATOR	Actuator type	LINEAR, ROTARY	-	LINEAR
P11	AUTO_ADJ	Autoadjust	Command/Function is being run	-	-
P1.2	ADJ_MODE	Automatic adjustment mode	FULL, STROKE, CTRL, PAR, ZERO_POS, LOCKED	-	FULL
P1.3	TEST	Test	Command/Function is being run	-	INACTIV
P1.4	EXIT	Return to operating level	Command/Function is being run	-	NV_SAVE
P2.	SETPOINT				

3.3 4.20mA and 4-20mA HART parameter descriptions (SP7-10 and SP7-20)

Parameter	Display	Function		Possible parameter setting	Unit	Factory setting
P1._	STANDARD	Actuator type	Actuator type	LINEAR, ROTARY	---	LINEAR
P1.0	ACTUATOR	Auto adjust	Autoadjust	Function	---	---
P1.1	AUTO ADJ	Auto adjust mode	Automatic adjustment mode	FULL,STROKE,CTRL_PAR, ZERO_POS, LOCKED		FULL
P1.2	ADJ_MODE					
P1.3	TEST	Test	Test	Function	---	INACTIVE
P1.4	FIND_DEV	Find device	Find device	DISABLE, ONE TIME, CONTINOUS --- DISABLED		
P1.5	EXIT	Return	Return to operating level	Function	---	NV SAVE
P2._	SETPOINT					
P2.0	MIN_RGE	Min setpoint range	Min. setpoint range	4.0 ... 18.4	mA	4.0
P2.1	MAX_RGE	Max setpoint range	Max. setpoint range	20.0 ... 5.6	mA	20.0
P2.2	CHARACT	Ch aract. curve	Characteristic curve	LINEAR, 1 :25, 1 50, 25 1, 50 1, USERD	---	LINEAR
P2.3	ACTION	Valve action	Effective direction	DIRECT, REVERSE	---	DIRECT
P2.4	SHUT_CLS	Shut-off value 0%	Shut-off value 0 %	OFF, 0.1 ... 45.0	%	1.0
P2.5	SHUT_OPN	Shut off value 100%	Shut-off value 100 %	55.0 ... 100.0, OFF	%	OFF
P2.6	RAMP UP	Set point ramp, up	Setpoint ramp (up)	OFF, 0 ... 200	---	OFF
P2.7	RAMP DN	Set point ramp, down	Setpoint ramp (down)	OFF, 0 ... 200	---	OFF
P2.8	EXIT					
P3._	ACTUATOR					
P3.0	MIN_RGE	Return	Return to operating level	Function	---	NV SAVE
P3.1	MAX_RGE	Min. of stroke range	Operating range, min.	0.0 ... 90.0 % 0.0		
P3.2	ZERO_POS	Max. of stroke range	Operating range, max.	100.0 ... 10.0 % 100		
P3.3	EXIT	Zero position	Zero position	CLOCKWISE, CTCLOCKWISE	---	CTCLOCKWISE

Parameter	Display	Function		Possible parameter setting	Unit	Factory setting
P4._	MESSAGES					
P4.0	TIME_OUT	Control time out	Dead band time limit	OFF, ... 200	---	OFF
P4.1	POS_SW1	Position switch 1	Switching point SW1	0.0 ... 100.0	%	0.0
P4.2	POS_SW2	Position switch 2	Switching point SW2	0.0 ... 100.0	%	100.0
P4.3	SW1_ACTV	Switchpoint 1 enable	Active direction SW1	FALL_BEL, EXCEED	---	FALL_BEL
P4.4	SW2_ACTV	Switchpoint 2 enable	Active direction SW2	FALL_BEL, EXCEED	---	EXCEED
P4.5	EXIT	Return	Return to operating level	Function	---	NV_SAVE
P5._	ALARMS					
P5.0	LEAKAGE	Leakage detection	Leakage to actuator	ACTIVE, INACTIVE	---	INACTIVE
P5.1	SP_RGE	Setpoint rng monitor	Outside the setpoint range	ACTIVE, INACTIVE	---	INACTIVE
P5.2	SENS_RGE	Sens. range monitor	Operating range exceeded	ACTIVE, INACTIVE	---	INACTIVE
P5.3	CTRLER	Controller monitor	Controller inactive	ACTIVE, INACTIVE	---	INACTIVE
P5.4	TIME_OUT	Control time out	Dead band time limit	ACTIVE, INACTIVE	---	INACTIVE
P5.5	STRK_CTR	Stroke counter	Movement counter	ACTIVE, INACTIVE	---	INACTIVE
P5.6	TRAVEL	Travel counter	Travel counter	ACTIVE, INACTIVE	---	INACTIVE
P5.7	EXIT	Return	Return to operating level	Function	---	NV_SAVE
P6._	MAN ADJ					
P6.0	MIN VR	Min. valve range	Operating range, min.	0.0 ... 100.0 % 0		
P6.1	MAX VR	Max. valve range	Operating range, max.	0.0 ... 100.0 % 100		
P6.2	ACTUATOR	Actuator type	Actuator type	LINEAR, ROTARY	---	LINEAR
P6.3	SPRNG Y2	Spring action (Y2)	Spring action (Y2)	CLOCKWISE, CTCLOCKWISE	---	CTCLOCKWISE
P6.4	DANG DN	Dead angle close	Dead angle 0 %	0.0 ... 45.0	%	0.0
P6.5	DANG UP	Dead angle open	Dead angle 100 %	55.0 ... 100.0	%	100.0
P6.6	BOLT POS	Bolt position	Actuator position	LEVER, STEM	---	LEVER
P6.7	EXIT	Return	Return to operating level	Function	---	NV_SAVE

Parameter	Display	Function		Possible parameter setting	Unit	Factory setting
P7._	CTRL PAR					
P7.0	KP UP	KP value, up	KP value (up)	0.1 ... 120.0	---	5
P7.1	KP DN	KP value, down	KP value (down)	0.1 ... 120.0	---	5
P7.2	TVUP	TVvalue, up	IV value (up)	10 ... 450	---	200
P7.3	TVDN	TV value, down	IV value (down)	10 ... 450	---	200
P7.4	Y-OFS UP	Y offset, up	Y offset (up)	0.0 ... 100.0	%	48.0
P7.5	Y-OFS DN	Y offset, down	Y offset (down)	0.0 ... 100.0	%	48.0
P7.6	TOL BAND	Tolerance band (zone)	Tolerance band (zone)	0.3 ... 10.0	%	2.0
P7.7	DEADBAND	Dead band	Dead band	0.10 ... 10.00	%	0.20
P7.8	DB APPR	Deadband Approach	Dead-band approach	SLOW, MEDIUM, FAST		MEDIUM
P7.9	TEST	Test	Test	Function	---	INACTIVE
P7.10	DB CALC	Deadband calculat.	Dead-band determination	ON, OFF	---	ON
P7.11	LEAK SEN	Leakage sensivity	Leakage sensitivity	1 ... 7200	s	30
P7.12	CLOSE UP	Pos. time out	Position monitoring	0.0 ... 100.0	%	0.30
P7.13	EXIT	Return	Return to operating level	Function	---	NV SAVE
P8._	ANLG OUT					
P8.0	MIN RGE	Min. range	Min. current range	4.0 ... 18.4	mA	4.0
P8.1	MAX RGE	Max. range	Max. current range	20.0 ... 5.7	mA	20.0
P8.2	ACTION	Action	Direction of action of characteristic curve	DIRECT, REVERSE	---	DIRECT
P8.3	ALARM	Alarm current	Alarm message	HIGH CUR, LOW CUR	---	HIGH CUR
P8.4	RB_CHAR	Read back character	Converted characters	DIRECT, RECALC		DIRECT
P8.5	TEST	Test	Test	Function	---	NONE
P8.6	ALR_ENAB	Alarm function	Alarm via analog output	ON, OFF	---	ON
P8.7	CLIPPING	Current signal enabled Signal clipping range	Extension of signal output to 3.8 ... 20.5 mA	4.0 ... 20.0; 3.8 ... 20.5 mA	mA	4.0 ... 20.0
P8.8	EXIT	Return	Return to operating level	Function	---	---

Parameter	Display	Function		Possible parameter setting	Unit	Factory setting
P9._	DIG OUT					
P9.0	ALRM LOG	Alarm logic	Alarm output logic	ACTIVE HI, ACTIVE LO	---	ACTIVE HI
P9.1	SW1 LOG	Switchpoint 1 logic	Logic SW1	ACTIVE HI, ACTIVE LO	---	ACTIVE HI
P9.2	SW2 LOG	Switchpoint 2 logic	LogicSW2	ACTIVE HI, ACTIVE LO	--	ACTIVE HI
P9.3	ALRM_DO	Alarm Status	Alarm Status	ACTIVE, INACTIVE	---	INACTIVE
P9.4	TEST	Test	Test	NONE, ALRM_ON, SW1_ON, SW2_ON, ALL ON	---	NONE
P9.5	EXIT	Return	Return to operating level	Function	---	NV SAVE
P10._	DIG IN					
P10.0	FUNCTION Function select	Function selection	POS HOLD	NONE, POS_0 %, POS_100 %, POS HOLD	---	NONE
P10.1	EXIT	Return	Return to operating level	Function	---	---
P11._	FS / IP					
P11.0	FAIL POS	Save position	Safe position	ACTIVE, INACTIVE	---	INACTIVE
P11.1	FACT SET	Factory setting	Factory Setting	Function	---	NO F POS
P11.2	IP-TYP	1/P module type	Type of 1/P module	NO_F_POS, F_SAFE_1, F_SAFE_2, F_FREEZE1, F_FREEZE2	---	[CUSTOM]
P11.3	IP_COMP	IP compensation	IP compensation	ON, OFF	---	ON
P11.4	HART	REV HART revision	HART Revision	5; 7	---	5
P11.5	EXIT	Return	Return to operating level	Function	---	NV SAVE

3.4 HART parameter overview (Graphic)

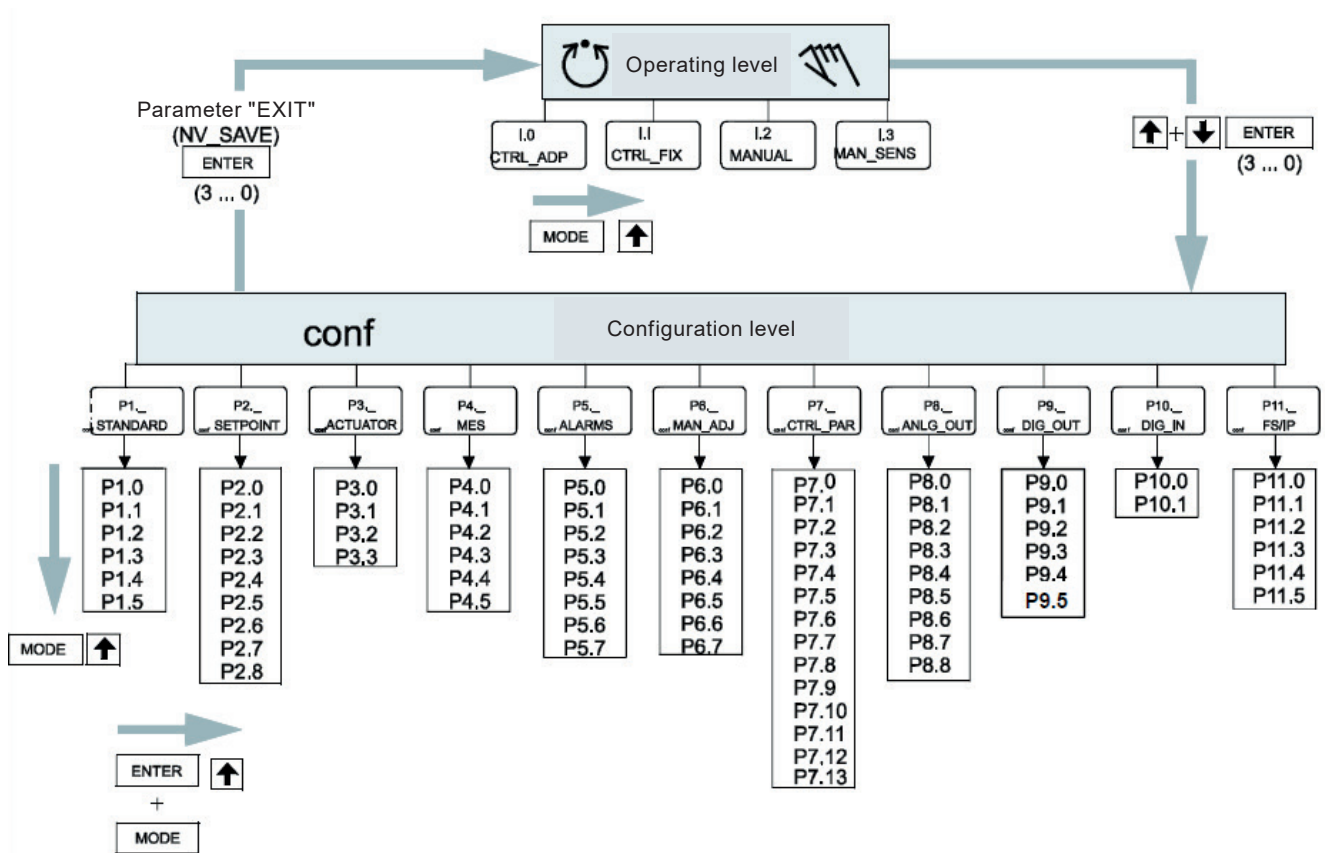

Fig 2

3.5 Parameter group 1: Standard



3.5.1 ACTUATOR – Actuator type



With this parameter you can configure the positioner for operation on a linear actuator (sensor range $\pm 30^\circ$) or on a part-turn actuator (sensor range $\pm 45^\circ$). No mechanical modifications to the positioner are required.

NOTE	
i	After changing the actuator type, it is recommended that you run automatic adjustment to prevent linearity errors.

Selection	LINEAR	Linear actuator
	ROTARY	Part-turn actuator

3.5.2 AUTO_ADJ – automatic adjustment



The following values are determined during Auto Adjust:

- Direction of action of the actuator
- Direction of action of the reset spring
- Actuator travel of the multi-turn actuator / final control element
- Stroke time for both directions
- Control parameters
- Offset for the I/P module

NOTE	
i	The mode and scope of the automatic adjustment function can be selected using parameter ADJ MODE.

To start the automatic adjustment, press and hold ENTER until the countdown from 3 to 0 is finished. During the countdown, the automatic adjustment mode selected using parameter ADJ_MODE is shown on the display. While Autoadjust is running, the control loop symbol flashes in the display, and the current state of Autoadjust is indicated with the messages listed below.



(No acknowledgement)

NOTE	
i	The configured setpoint range must not be smaller than 20 % (3.2 mA).

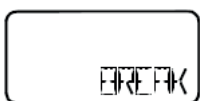

(Acknowledgement required)

RUN	Autoadjust is running.
CALC_ERR	Error during plausibility check.
COMPLETE.	Autoadjust completed successfully.
BREAK	Autoadjust has been stopped by the operator. This can be done locally by pressing ENTER.
OUTOFRNG	Sensor range of the positioner has been exceeded; Autoadjust was stopped.
NO_SCALE	End positions have not yet been determined; therefore, partial Autoadjust cannot be run
RNG_ERR	Less than 10% of the sensor range is used.
TIMEOUT	Timeout. The control parameters could not be determined within 200 seconds. Automatic adjustment was stopped.
SPR_ERR	The actual spring action does not match the configured spring action

Once Autoadjust has finished running without encountering any errors, the device displays the message "RUN" in the bottom line and a code number in the top line, indicating the step that is currently being executed:

10	Air is completely evacuated from actuator (OUT1). The fully evacuated position is saved.
20	Air is completely ventilated from actuator (OUT1). The fully ventilated position is saved.
30	Determining stroke time is prepared.
31	Actuator travels from 0% to 100%, stroke time is measured and saved.
32	Actuator travels from 100% to 0%, stroke time is measured and saved.
40 - 49	Tolerance band is determined and saved (minimum value). PD parameters for fast control < tolerance band is determined and saved.
50 - 59	PID parameters for fast control < tolerance band is determined and saved.
200	Automatic adjustment is complete.

If a partial run of automatic adjustment has been selected (see parameter DANG_DN on page 20), the following code numbers are shown:

Stops only	Steps 10 ... 32 and step 200
Parameters only	Steps 40 ... 120 and step 200
Zero Only: 10	Air is completely evacuated from actuator (OUT1). The fully evacuated position is saved.
Zero Only 200	Automatic adjustment is complete.

3.5.3 ADJ_MODE – Automatic adjustment mode



Use this parameter to define the mode or scope of the Auto Adjust function.

FULL	Complete Autoadjust
STROKE	Stops only
CTRL_PAR	Control parameters only
ZERO_POS	Zero position only (configured stops required)
LOCKED	No Autoadjust

3.5.4 TEST - Test



The test is used to activate the positioner, and you can check the effects of the changes to this parameter group, e.g., by introducing setpoint changes or setpoint ramps using a current source.

Normally, INACTIVE is shown in the display. To start the test, press and hold ENTER until the countdown from 3 to 0 is finished. The test is activated. The display shows the control loop symbol and a flashing message. The test is automatically stopped after two minutes and can also be stopped by pressing any button.

NOTE	
i	It is not possible to start the test when the safe position is active (see the FAIL_POS parameter on page 50.) Instead, the message FAIL POS is displayed.

3.5.5 FIND_DEV – Find device



This function is only possible with HART 7 and enables identification of the affected device in the system. Following activation, the device sends a signal on request under HART 7. The following signals are available:

- Disable
- One time
- Continuous

3.5.6 EXIT – Return to operating level



With this parameter you can leave the configuration level. The positioner returns to the operating level. Here you can either save data in the non-volatile memory or discard all previously made changes (also the changes in other parameter groups).

To leave the configuration level (with or without saving), press and hold ENTER until the countdown from 3 to 0 is finished.

The active saving process is indicated by the message NV_SAVE. After saving a plausibility check is executed.

If an error occurs during the check or while saving, the data cannot be saved and an error message is displayed instead (see Chapter "Error codes").

Selection	NV_SAVE	Saves settings in the non-volatile memory.
	CANCEL	Discards all changes made since the last permanent save operation.

3.6 Parameter group 2: Setpoint



3.6.1 MIN_RGE – Setpoint range min.



The setpoint range is the input current range as a percentage of the working range for the valves and fittings (from 0 ... 100 %).

NOTE	
i	The configured setpoint range must not be smaller than 20 % (3.2 mA).

Use the MIN_RGE parameter to determine the lower limit of the setpoint range. You can enter a value within the admissible value range of 4 ... 18.4 mA, with one decimal.

3.6.2 MAX_RGE – Setpoint range max.

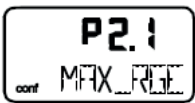

The setpoint range is the input current range as a percentage of the working range for the valves and fittings (from 0 ... 100 %).

NOTE	
i	The configured setpoint range must not be smaller than 20 % (3.2 mA).

Use the MAX_RGE parameter to determine the upper limit of the setpoint range. You can enter a value within the admissible value range of 5.6 ... 20 mA, with one decimal.

Setting examples	Setpoint Range	Min. = 8.3 mA, Max. = 15.6 mA
	Split range configuration between	Min. = 12.0 mA, Max. = 20.0 mA

3.6.3 CHARACT – Characteristic curve



Use this parameter to select a function that adjusts the behavior of the positioner to the analog input signal according to a predefined course.

This linearizes the characteristic curves for the valves and fittings and improves the behavior of the overall control loop.

In addition to five predefined characteristic curves, you can also select a user-configurable characteristic curve, which can only be generated and saved in the device via a PC with the appropriate configuration program (and not locally).

Selection	LINEAR	Linear
	EP 1/25	equal percentage 1:25
	EP 1/50	equal percentage 1:50
	EP 25/1	equal percentage 25:1
	EP 50/1	equal percentage 50:1
	USERDEF	configurable by user
	USERDEF	LINEAR

3.6.4 ACTION – Direction of action (setpoint signal)



The direction of action describes the relationship between the analog setpoint and pneumatic output OUT1.

Increasing	Setpoint 0 ... 100 % to Output 0 ... 100 %
Decreasing	Setpoint 0 ... 100 % to Output 0 ... 100 %

Selection	DIRECT	Increasing Control signal 4 ... 20 mA, and setpoint 0 ... 100 % = position 0 ... 100 %
	REVERSE	Decreasing Control signal 20 ... 4 mA, and setpoint 100 ... 0 % = position 0 ... 100 %

3.6.5 SHUT_CLS – Shut-off value 0%



The shut-off value SHUT_CLS is a percentage of the operating range (with one decimal place) from which the 0 % position is approached. Once the specified position limit value is reached, the actuator moves into the 0% end position.

As a result, the valve is moved in control mode into the mechanical 0% end position through full evacuation or ventilation.

In the 0 % end position, it continues to be adjusted to the position setpoint.

3.6.6 SHUT-OPN – Shut-off value 100%



The shut-off value SHUT-OPN is a percentage of the operating range (with one decimal place) from which the 100 % position is approached. Once the specified position limit value is reached, the actuator moves into the 100% mechanical end position.

In the 100 % end position, it continues to be adjusted to the position setpoint. When entering a value, the valve is moved in control mode into the mechanical 100% end position through full evacuation or ventilation.

Settings for Autoadjust:	Rotary actuators = 99	When the limit value is reached, the actuator is fully ventilated.
	Linear actuators = 100	Controlling continues in the 100% position.

3.6.7 RAMP UP – Setpoint ramp (up)



Here the stroke time for the actuator can be increased. A setpoint change is not directly transferred to the positioner; instead, the speed is reduced accordingly. The set value should always be greater than the shortest stroke time determined during auto adjust.

NOTE	
i	To display the stroke time (stroke time up), press and hold the ENTER button.



CAUTION	
	<p>The setpoint ramp is deactivated in the case of any functions which involve approaching the safe position . This even applies in the case of errors. The actuator will therefore move without delay</p> <ul style="list-style-type: none"> - Do not reach into the adjustment mechanism.

3.6.8 RAMP DN – Setpoint ramp (down)



Here the stroke time for the actuator can be increased. A setpoint change is not directly transferred to the positioner; instead, the speed is reduced accordingly. The set value should always be greater than the shortest stroke time determined during auto adjust.

NOTE	
	To display the stroke time (stroke time up), press and hold the ENTER button.



CAUTION	
	<p>The setpoint ramp is deactivated in the case of any functions which involve approaching the safe position. This even applies in the case of errors. The actuator will therefore move without delay</p> <ul style="list-style-type: none"> - Do not reach into the adjustment mechanism.

3.6.9 EXIT – Return to operating level

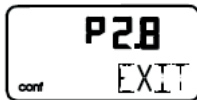

With this parameter you can leave the configuration level. The positioner returns to the operating level. Here you can either save data in the non-volatile memory or discard all previously made changes (also the changes in other parameter groups).

To leave the configuration level (with or without saving), press and hold ENTER until the countdown from 3 to 0 is finished.

The active saving process is indicated by the message NV_SAVE. After saving a plausibility check is executed.

If an error occurs during the check or while saving, the data cannot be saved and an error message is displayed instead (see Chapter "Error codes").

Selection	NV_SAVE	Saves settings in the non-volatile memory.
	CANCEL	Discards all changes made since the last permanent save operation.

3.7 Parameter group 3: Operating range





3.7.1 MIN_RGE – Operating range min.



The working range can be configured to be smaller than the maximum mechanical working range.

The setpoint range always refers to the configured working range. Use this parameter to specify the lower limit of the operating range.

CAUTION	
	<p>This function is only active in control mode. In the event of a power supply failure (electric or pneumatic), and in manual mode, the mechanical end positions are reapproached.</p> <ul style="list-style-type: none"> - Do not reach into the adjustment mechanism.

NOTE	
	<p>The operating range must be greater than 10% of the sensor range.</p>

NOTE	
	<p>The display of the positioner in operating modes 1.0 through 1.2 always refers to the configured working range and indicates the position in %.</p>

3.7.2 MAX_RGE – Operating range max.



The working range can be configured to be smaller than the maximum mechanical working range.

The setpoint range always refers to the configured working range. Use this parameter to specify the upper limit of the working range

CAUTION	
	<p>This function is only active in control mode. In the event of a power supply failure (electric or pneumatic), and in manual mode, the mechanical end positions are approached</p> <ul style="list-style-type: none"> - Do not reach into the adjustment mechanism.

NOTE	
	<p>The operating range must be greater than 10% of the sensor range.</p>

NOTE	
	<p>The display of the positioner in operating modes 1.0 through 1.2 always refers to the configured working range and indicates the position in %.</p>

3.7.3 ZERO_POS – Zero position



With this parameter you can assign the zero position of the display to the zero position of the valves and fittings. It also allows you to select the direction of rotation of the sensor shaft (looking at the open housing).

NOTE	
	<p>Normally, the zero position is determined automatically and saved during standard Autoadjust.</p>

Linear actuators → counterclockwise

Rotary actuators → clockwise

Selection	CLOCKW	Limit stop reached turning clockwise
	CTCLOCKW	Limit stop reached turning counterclockwise

3.7.4 EXIT – Return to operating level



With this parameter you can leave the configuration level. The positioner returns to the operating level. Here you can either save data in the non-volatile memory or discard all previously made changes (also the changes in other parameter groups).

To leave the configuration level (with or without saving), press and hold ENTER until the countdown from 3 to 0 is finished.

The active saving process is indicated by the message NV_SAVE. After saving a plausibility check is executed.

If an error occurs during the check or while saving, the data cannot be saved and an error message is displayed instead (see Chapter "Error codes").

Selection	NV_SAVE.	Saves settings in the non-volatile memory.
	CANCEL	Discards all changes made since the last permanent save operation.

3.8 Parameter group 4: Messages



3.8.1 TIME_OUT – Dead band time limit



With this parameter you enter the monitoring time until reaching the setpoint.

When the tolerance band is exceeded, the monitoring time is started.

If the tolerance band within the predefined time is again not reached by the new position setpoint, an alarm is triggered. (Parameter TIME_OUT in parameter group 5 must be activated.)

CAUTION



With active shutdown function there is no alarm message.

Once the setpoint has been reached, the alarm is automatically reset.



NOTE	
i	The stroke time to be monitored should be 1.5 to 2x greater than the shortest stroke time selected during automatic adjustment.

Press and hold the ENTER button to display the stroke time. Press ENTER again to toggle between UP stroke time and DOWN stroke time.

3.8.2 POS_SW1 – Switching point SW1



With this parameter you can define the switching point SW1 as a percentage of the operating range. If the position is above or below SW1, the corresponding signal output on the plug-in module is activated (see also parameter group DIG_OUT).

NOTE	
i	Changing the operating range also changes the positions of the switching points with respect to the position of the valves and fittings.

3.8.3 POS_SW2 – Switching point SW2



With this parameter you can define the switching point SW2 as a percentage of the operating range. If the position is above or below SW2, the corresponding signal output on the plug-in module is activated (see also parameter group DIG_OUT).

NOTE	
i	Changing the operating range also changes the positions of the switching points with respect to the position of the valves and fittings.

Exceed	Message when exceeding switch point SW2
FALL_BEL	Message when falling below switching point SW2

3.8.4 SW1_ACTV – Active direction SW1



With this parameter you define whether a message is to be triggered for exceeding or falling below switching point SW1.

EXCEED.	Message when exceeding switching point SW2.
FALL_BEL	Message when falling below switching point SW2.

3.8.6 EXIT – Return to operating level



With this parameter you can leave the configuration level. The positioner returns to the operating level. Here you can either save data in the non-volatile memory or discard all previously made changes (also the changes in other parameter groups).

To leave the configuration level (with or without saving), press and hold ENTER until the countdown from 3 to 0 is finished. The active saving process is indicated by the message NV_SAVE. After saving a plausibility check is executed.

If an error occurs during the check or while saving, the data cannot be saved and an error message is displayed instead (see Chapter "Error codes").

NV_SAVE.	Saves settings in the non-volatile memory.
CANCEL	Discards all changes made since the last permanent save operation.

3.9 Parameter group 5: Alarms



NOTE	
i	Active alarms are signaled at the digital output and using the "Analog feedback" option.

3.9.1 LEAKAGE – Leakage at actuator



If the monitoring function detects leakage at the actuator, a message is issued via alarm output on the mainboard.

ACTIVE	Monitoring active.
INACTIVE	Monitoring inactive.

3.9.2 SP_RGE – Setpoint monitoring



With this parameter, you can determine that a corresponding alarm is signaled via the digital output when falling below or exceeding the setpoint range (<3.8 mA or above 20.5 mA).

ACTIVE	Setpoint monitoring active.
INACTIVE	Setpoint monitoring inactive.

3.9.3 SENS_RGE – Operating range exceeded

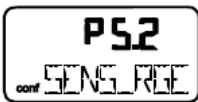

With this parameter you can determine that an alarm is signaled via the digital output when the configured operating range is exceeded by 4%. (Position < -4 % or > 104 %). This may indicate improperly adjusted mounting or mechanical wear in a limit stop.

ACTIVE	Alarm active
INACTIVE	Alarm not active

3.9.4 CTRLER – Controller inactive



You can use this parameter to specify signaling of an alarm via a digital output if the positioner is not active, i.e., if the control mode is interrupted by another operating mode or by configuration.

For details of which statuses lead to a message, see chapter "alarm codes"

ACTIVE	Alarm active
INACTIVE	Alarm not active

3.9.5 TIME_OUT – Dead band time limit



Use this parameter to activate the "Dead band time limit" function.

The alarm is issued via digital output when the setpoint within the specified monitoring time is not reached in control mode. (The monitoring time is entered with parameter group 4, „TIME_OUT“.) The function is only active in control modes ACTUATOR and AUTO_ADJ.

ACTIVE	Dead band time limit is activated.
INACTIVE	Alarm not active

3.9.6 STRK_CTR – Movement counter



With this parameter you can determine that an alarm is signaled when the movement counter exceeds the specified limit value. The limit value is edited remotely via PC.

ACTIVE	Alarm for exceeding travel counter limit value
INACTIVE	No alarm

3.9.7 TRAVEL – Travel counter



With this parameter you can determine that an alarm is signaled when the travel counter exceeds the specified limit value. The limit value is edited remotely via PC.

ACTIVE	Alarm for exceeding movement counter limit value
INACTIVE	No alarm

3.9.8 EXIT – Return to operating level



With this parameter you can leave the configuration level. The positioner returns to the operating level. Here you can either save data in the non-volatile memory or discard all previously made changes (also the changes in other parameter groups).

To leave the configuration level (with or without saving), press and hold ENTER until the countdown from 3 to 0 is finished.

The active saving process is indicated by the message NV_SAVE. After saving a plausibility check is executed.

If an error occurs during the check or while saving, the data cannot be saved and an error message is displayed instead (see Chapter "Error codes").

NV_SAVE	Saves settings in the non-volatile memory.
CANCEL	Discards all changes made since the last permanent save operation.

3.10 Parameter group 6: Manual adjustment



3.10.1 MIN_VR – Operating range min.



Normally, the operating range is determined automatically during Autoadjust. A partial run of automatic adjustment that is limited to the controller parameters (CTRL_PAR, see parameter DANG_DN) or valves and fittings without end stops, however, requires manual adjustment of the operating range.

CAUTION



Risk of injury!

After manual adjustment of the end positions, it is essential to limit the operating range to > 0.1 and < 99.9 under MIN_RGE and MAX_RGE. Otherwise, the valves and fittings may be driven at full speed to an end position.

- Do not reach into the adjustment mechanism.

The range between high and low limit value must be at least 10% of the full range. Otherwise, the message VR< 10 % is displayed.

NOTE



Use as large are range as possible. This parameter is not active when the safe position is active. The display then shows the message FAIL POS.

Use MIN_VR to determine the lower limit of the operating range.

3.10.2 MAX_VR – Operating range max.



Normally, the operating range is determined automatically during Autoadjust. A partial run of automatic adjustment that is limited to the controller data (STANDARD, see parameter ADJ_MODE) or valves and fittings without end stops, however, requires manual adjustment of the operating range.

CAUTION	
	<p>Risk of injury! After manual adjustment of the end positions, it is essential to limit the operating range to > 0.1 and < 99.9 under MIN_RGE and MAX_RGE. Otherwise, the valves and fittings may be driven at full speed to an end position.</p> <ul style="list-style-type: none"> - Do not reach into the adjustment mechanism.

The range between high and low limit value must be at least 10% of the full range. Otherwise, the message VR< 10 % is displayed.

NOTE	
	<p>Use as large are range as possible. This parameter is not active when the safe position is active . The display then shows the message FAIL POS.</p>

Use MAX_VR to determine the upper limit of the operating range.

ARROW UP or ARROW DOWN	Press in order to travel to desired position.
ENTER	Press and hold until the countdown has completed (MIN_SET. The position is saved as the minimum limit value
ENTER	Press briefly. The set limit value is displayed for 2 seconds (MIN_SAVE).

3.10.3 ACTUATOR – Actuator type





With this parameter you can configure the positioner for operation on a linear actuator (sensor range $\pm 30^\circ$) or on a part-turn actuator (sensor range $\pm 45^\circ$). No mechanical modifications to the positioner are required.

NOTE	
	<p>After changing the actuator type , it is recommended that you run Auto Adjust to prevent linearity errors.</p>

Selection	Linear actuators
	Part-turn actuators

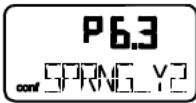
3.10.4 SPRNG_Y2 – Spring action (Y2)



CAUTION	
	<p>Risk of injury! Incorrect entries may result in the actuator traveling to a mechanical stop at full speed.</p>

Use this parameter to specify the end position to which the reset spring of the pneumatic actuator drives the valves and fittings in the event that the power supply fails. The corresponding end stop is determined during Autoadjust. If, however, only the controller data are determined (STANDARD, see parameter ADJ_MODE), the spring action must be entered manually. Select the direction of rotation of the sensor shaft (looking at the open housing) for when the safe position is approached as a result of the spring force (actuator exhausts via OUT1). For double-acting actuators, the spring action has the same effect as ventilating the pneumatic output OUT2.

CLOCKW	Stop reached turning clockwise
CTCLOCKW	Stop reached turning counterclockwise

3.10.5 DANG_DN – Dead Angle Close



Use this parameter to cut off the unusable range of the valve flow characteristic curve from the point of view of control. The Dead Angle Close is a percentage of the operating range to which the valve is moved if the input signal is 4.16 mA.

3.10.6 DANG_UP – Dead Angle Open



Use this parameter to cut off the unusable range of the valve flow characteristic curve from the point of view of control. The Dead Angle Open is a percentage of the operating range to which the valve is moved if the input signal is 19.84 mA.

3.10.7 BOLT_POS – Actuator position



The installation type of the actuator bolt for the potentiometer has a decisive influence on the linearization of the potentiometer signal.

Using the function BOLT_POS, this installation type is taken into account in the algorithm. The following options can be selected:

- STEM (actuator bolt on the valve spindle)
- LEVER (actuator bolt on the potentiometer lever)

For detailed information about the position of the actuator bolt, see the operating instructions.

3.10.8 EXIT – Return to operating level



With this parameter you can leave the configuration level. The positioner returns to the operating level. Here you can either save data in the non-volatile memory or discard all previously made changes (also the changes in other parameter groups).

To leave the configuration level (with or without saving), press and hold ENTER until the countdown from 3 to 0 is finished.

The active saving process is indicated by the message NV_SAVE. After saving a plausibility check is executed.

If an error occurs during the check or while saving, the data cannot be saved and an error message is displayed instead (see Chapter "Error codes").

NV_SAVE	Saves settings in the non-volatile memory.
CANCEL	Discards all changes made since the last permanent save operation.

3.11 Parameter group 7: Control parameters



3.11.1 KP UP – KP value (up)



NOTE	
	In the case of most actuators, all control parameters can be optimized by using Auto Adjust. Changes should only be made when auto adjust cannot be executed or control stability cannot be achieved.

The KP value is the gain of the controller. The control speed and stability are influenced by the KP value. With higher KP values, the control speed increases.

NOTE	
	The control precision is not affected by the KP value.

To compensate for existing dissymmetries in the controlled system, the KP value should be set separately for both positioning directions (up / down).

For most actuators, a satisfactory control response is achieved with a KP value in the 2.0 ... 10.0 range. Use the parameter KP UP to adjust the KP value for the upward positioning direction (towards 100 %).

3.11.2 KP DN – KP value (down)



NOTE	
i	In the case of most actuators, all control parameters can be optimized by using Auto Adjust. Changes should only be made when auto adjust cannot be executed or control stability cannot be achieved.

The KP value is the gain of the controller. The control speed and stability are influenced by the KP value. With higher KP values, the control speed increases.

NOTE	
i	The control precision is not affected by the KP value.

To compensate for existing asymmetries in the controlled system, the KP value should be set separately for both positioning directions (up / down). For most actuators, satisfactory control behavior is achieved with a KP value between 2.0 ... 10.0. Use the KP DN parameter to adjust the KP value for the downward positioning direction (towards 0 %).

3.11.3 TV UP – TV value (up)

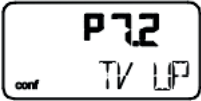

NOTE



In the case of most actuators, all control parameters can be optimized by using Auto Adjust. Changes should only be made when auto adjust cannot be executed or control stability cannot be achieved.

The TV value is the derivative time of the controller. The control speed and stability are affected by the TV value in such a way that it counteracts the KP value dynamically. The control speed decreases as the TV value increases. To compensate for existing dissymmetries in the controlled system, the TV value should be configured separately for both positioning directions (up / down). Use the TV UP parameter to adjust the TV value for the upward positioning direction (towards 100 %).

3.11.4 TV DN – TV value (down)

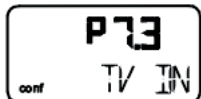

NOTE



In the case of most actuators, all control parameters can be optimized by using Auto Adjust. Changes should only be made when auto adjust cannot be executed or control stability cannot be achieved.

The TV value is the derivative time of the controller. Control speed and stability are affected by the TV value in terms of how this dynamically counteracts the KP value. The control speed decreases as the TV value increases. To compensate for existing asymmetries in the controlled system, the TV value should be configured separately for both positioning directions (up / down). Use the TV DN parameter to adjust the TV value for the downward positioning direction (towards 0 %).

3.11.5 Y-OFS UP – Y offset (up)



NOTE



In the case of most actuators, all control parameters can be optimized by using Auto Adjust. Changes should only be made when auto adjust cannot be executed or control stability cannot be achieved.

The "offset for the setpoint signal" linearizes the behavior of the I/P module used and enables rapid compensation even in the case of small control deviations. The value is limited at The lower end by a minimum value (neutral zone).

The offset significantly affects the control speed for control deviations of less than 5 %.

In manual modes MANUAL and MAN_SENS, the offset values are issued to the I/P module for fine adjustment. With larger, slower actuators, Autoadjust may determine offset values higher than 80 %. In these cases there will be no noticeable difference between fine and coarse adjustment while in manual mode.

To compensate for existing asymmetries in the controlled system, the offset should be configured separately for both positioning directions (up / down).

For most actuators, satisfactory control behavior is achieved with offset values between 40 ... 80 %. If, in the event of setpoint changes, the control behavior demonstrates an overshoot of less than 2 %, both offset values should be decreased.

Both offset values should be increased when the actuator stops outside the tolerance band.

Use the parameter Y-OFS UP to adjust the Y offset for the upward positioning direction (towards 100 %).

3.11.6 Y-OFS DN – Offset (down)



NOTE	
i	In the case of most actuators, all control parameters can be optimized by using Auto Adjust. Changes should only be made when auto adjust cannot be executed or control stability cannot be achieved.

The "offset for the setpoint signal" linearizes the behavior of the I/P module used and enables rapid compensation even in the case of small control deviations. The value is limited at the lower end by a minimum value (neutral zone).

The offset significantly affects the control speed for control deviations of less than 5 %.

In manual modes MANUAL and MAN_SENS, the offset values are issued to the I/P module for fine adjustment. For larger, slower actuators Autoadjust may determine values higher than 80 %. In these cases there will be no noticeable difference between fine and coarse adjustment while in manual mode.

To compensate for existing asymmetries in the controlled system, the offset should be configured separately for both positioning directions (up / down).

For most actuators, a satisfactory control response is achieved with offset values in the 40 ... 80 % range. If, in the event of setpoint changes, the control behavior demonstrates an overshoot of less than 2 %, both offset values should be decreased.

Both offset values should be increased when the actuator stops outside the tolerance band. Use the parameter Y-OFS DN to adjust the Y offset for the downward positioning direction (towards 0 %).

3.11.7 TOL_BAND – Tolerance band



The "tolerance band" TOL_BAND defines a \pm range around the position setpoint. When the position of the valves and fittings reaches this range, the parameter set of the positioner is toggled to a different algorithm that is used to continue with a slow controlling action until the dead band DEADBAND is reached. The system is only considered balanced once the sensitivity range is reached (see parameter ADJ_MODE)

Input value	in steps of 0.1%
-------------	------------------

3.11.8 DB_APPR – Dead band approach



The "dead band" DEADBAND defines a \pm range around the position setpoint. Once the valves and fittings reach this range, the positioner maintains this position.

NOTE	
i	The dead band must always be 0.2% less than the tolerance band.

Input value In steps of 0.01%

3.11.9 DB_APPR – Dead band approach



The DB_APPR parameter specifies the speed at which the dead band is approached.

In rare cases, overshooting can occur when the valve position is being compensated. This can be prevented by reducing the speed of the dead-band approach.

TEST – Test



The test is used to activate the controller, and you can check the effects of the changes to this parameter group, e.g., by introducing setpoint changes or setpoint ramps using a current source.

Normally, INACTIVE is shown in the display. To start the test, press and hold ENTER until the countdown from 3 to 0 is finished. The test is activated. The display shows the control loop symbol and a flashing message.

The test is automatically stopped after two minutes and can also be stopped by pressing any button.

NOTE	
i	It is not possible to activate the test when the safe position is active (see parameter FAIL_POS on page 50). Instead, the message FAIL POS is displayed.

3.11.10 DB_CALC – Dead-band determination



In standard automatic adjustment, the algorithm determines the dead band as well as the end positions and control parameters. In some applications, you may need to perform a new automatic adjustment after installation in the system, but to leave the dead band at a preset value. DB_CALC offers the following setting options:

- ON (automatic adjustment with dead band determination)
- OFF (automatic adjustment without dead band determination)

3.11.11 LEAK_SEN – Leakage sensitivity



Determination of a possible leakage between the output positioner and the pneumatic actuator. If the valve position moves out of the dead zone (dead band) in the same direction seven times in succession within a defined time range, there is a high probability of a leakage in the connecting lines between the positioner and the pneumatic actuator. LEAK_SEN enables you to define the time range within which the valve may leave the dead band a maximum of seven times in succession before an alarm is generated. You can choose a time range of between 1 and 7200 seconds.

3.11.12 CLOSE_UP - Position monitoring

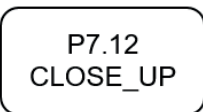

This parameter specifies a range around the deadband. If the valve reaches the CLOSE_UP range within a time < positioning timeout, the positioner does not send an alarm. If this time is > positioning timeout, the positioner generates an alarm.

CLOSE_UP is only used to influence the alarm behaviour.

The control process continues until the valve has reached the dead band.

The default-value is 0.30%; the valuation is 0.00 – 100.00 %.

Changes can be done in 0.01% steps.

3.11.13 EXIT – Return to operating level

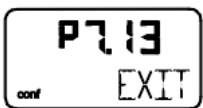

With this parameter you can leave the configuration level. The positioner returns to the operating level. Here you can either save data in the non-volatile memory or discard all previously made changes (also the changes in other parameter groups).

To leave the configuration level (with or without saving), press and hold ENTER until the countdown from 3 to 0 is finished.

The active saving process is indicated by the message NV_SAVE. After saving a plausibility check is executed.

If an error occurs during the check or while saving, the data cannot be saved and an error message is displayed instead (see Chapter "Error codes").

NV_SAVE	Saves settings in the non-volatile memory
CANCEL	Discards all changes made since the last permanent save operation

3.12 Parameter group 8: Analog output

(on the plug-in module for analog feedback)



3.12.1 MIN_RGE – Current range min.



Use this parameter to specify the lower current range limit for the analog feedback. The current range corresponds to the configured stroke range

NOTE	
i	The current range limits can be freely configured between 4 ... 18.5 mA. However, the current range must not be smaller than 10 % (1 .6 mA).

3.12.2 MAX_RGE – Current range max.

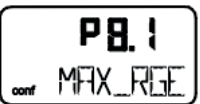

Use this parameter to specify the upper current range limit for the analog feedback.

NOTE	
i	The current range limits can be freely configured between 4 ... 20 mA. However, the current range must not be smaller than 10 % (1 .6 mA).

3.12.3 ACTION – Characteristic curve action



Use this parameter to specify the characteristic curve for the analog feedback.

Increasing	Position 0 ... 100 % = Signal 4 ... 20 mA
Decreasing	Position 0 ... 100 % = Signal 20 ... 4 mA

3.12.4 ALARM – Alarm



When an alarm / message is generated in the positioner, it is signaled via the digital and analog outputs. You can use the ALARM parameter to select a higher or lower alarm current for analog feedback

NOTE	
i	Without electrical power or during initialization the output signal is > 20.5 mA. A special version (hardware change) is also available, with which a value of < 3.8 mA is also possible.

HIGH_CUR	Alarm current I > 20.5 mA
LOW_CUR	Alarm current I < 3.8 mA

3.12.5 RB_CHAR – Count back characteristic curve



You can use this parameter to determine whether the position indicator and the analog position feedback follow the characteristic curve set in parameter CHARACT - Characteristic curve.

3.12.6 TEST – Test



Test is for simulation of the analog output. The test allows you to simulate effects during commissioning without affecting the normal process.

NOTE	
i	The test is automatically stopped after two minutes. While the test is running, the corresponding message (see below) flashes in the display.

NONE	No function
FAILED	Simulation of position feedback failure (CPU). I > 20.5 mA (standard) or I < 3.8 mA (special version, changed hardware)
ALRM_CUR	Simulation of an alarm current < 3.8 mA or I > 20.5 mA
CURRENT	Output of the current setpoint as current value via analog output. All configurations and settings of the analog input and /or output must be taken into consideration.

3.12.7 ALR_ENAB – Alarm via analog output



Enables the alarm signal to be switched on / off using the optional analog output module.
Selection option: ON / OFF.

3.12.8 CLIPPING – Extending the signal output range



Enables extension of the permissible signal output range to 3.8 ... 20.5 mA.
Selection option:
— 4.0 ... 20.0 mA
— 3.8 ... 20.5 mA

3.12.9 EXIT – Return to operating level

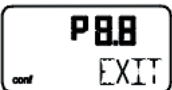

With this parameter you can leave the configuration level. The positioner returns to the operating level. Here you can either save data in the non-volatile memory or discard all previously made changes (also the changes in other parameter groups).

To leave the configuration level (with or without saving), press and hold ENTER until the countdown from 3 to 0 is finished.

The active saving process is indicated by the message NV_SAVE. After saving a plausibility check is executed.

If an error occurs during the check or while saving, the data cannot be saved and an error message is displayed instead (see Chapter "Error codes").

NV_SAVE.	Saves settings in the non-volatile memory.
CANCEL	Discards all changes made since the last permanent save operation

3.13 Parameter group 9: digital output



3.13.1 ALRM_LOG – Alarm output logic



With this parameter you can determine the logic level of the alarm output.

ACTIV_HI	active = output current $I > 2$ mA
ACTIV_LO	active = output current $I < 1$ mA

3.13.2 SW1_LOG – Logic

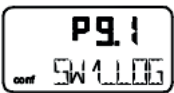

You can use this parameter to define the active state for switch output SW1 (on the plug-in module for digital feedback).

ACTIV_HI	active = output current $I > 2$ mA
ACTIV_LO	active = output current $I < 1$ mA

3.13.3 SW2_LOG – Logic

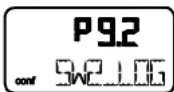

You can use this parameter to define the active state for switch output SW2 (on the plug in module for digital feedback).

ACTIV_HI	active = output current $I > 2$ mA
ACTIV_LO	active = output current $I < 1$ mA

3.13.4 ALRM_DO – Digital Output Status

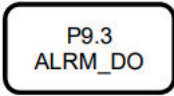

Use this parameter to determine the status of the digital outputs.

'ACTIVE' : Digital output (DO) is active
 'INACTIVE' : Digital output (DO) is NOT active

TEST

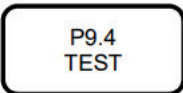

Test is for simulation of digital outputs (DO, SW1 and SW2).

NOTE	
	The test is automatically stopped after two minutes and can be aborted by pressing any button.

While the test is running, the corresponding message (see below) will be visible in the display.

NONE	No function
ALRM_ON	Alarm is simulated (DO active)
SW1_ON	Reaching switching point 1 is simulated (SW1 active)
SW2_ON	Reaching switching point 2 is simulated (SW2 active)
ALL_ON	Alarm and switching points are simulated (all DOs active)

Note: SW1 and SW2 must be fitted as options

3.13.5 EXIT – Return to operating level

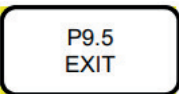

With this parameter you can leave the configuration level. The positioner returns to the operating level. Here you can either save data in the non-volatile memory or discard all previously made changes (also the changes in other parameter groups).

NV_SAVE	Saves settings in the non-volatile memory.
CANCEL	Discards all changes made since the last permanent save operation.

3.14 Parameter group 10: digital input



3.14.1 FUNCTION – Digital input function selection



For the digital input, one of the following protective functions can be selected via local operation.

- No function (default)
- Move to 0 % position
- Move to 100 % position
- Hold previous position
- Disable local configuration.
- Disable local configuration and operation
- Disable all access (local or via PC)

The selected function is activated when the 24 V signal is no longer connected to the digital output (< 10 V DC).

The safety functions POS_0 %, POS_100 % and POS_HOLD are executed on the operating level in both control operating modes P1.0 or P1.1. BIN_CTRL is shown in the display.

If a corresponding function is active, a corresponding value is defined internally for the positioner. The actuator is then driven into the end position or position specified under consideration of the set point ramp, configured operating range, selected behavior etc.

After selecting an operation lock CNF_LOCK, OP_LOCK or ALL_LOCK, the key icon is displayed, indicating that the operation lock will be activated at the next save.

After saving and without 24V at the digital input, the key is permanently displayed.

NOTE	
	The operation lock CNF_LOCK, OP_LOCK or ALL_LOCK is displayed only if the voltage is connected to the digital input.

CNF_LOCK	Local access to the configuration level is inhibited. However, local operation on the operating level is possible. The positioner can be configured externally (via LCI / modem and PC). When the operator tries to activate the configuration level, the text CNF_LOCK is displayed for approx. 5 seconds
----------	--

OP_LOCK	Local operation and configuration is completely inhibited. With every attempt to perform local operating actions, the message OP_LOCK is shown for approx. 5 seconds.
---------	---

NOTE	
	The positioner can be configured externally (via LCI / modem and PC).

ALL_LOCK	Local operation (operating level and configuration level) and external configuration via LCI / modem and PC are inhibited. With every attempt to perform local operating actions, the message ALL_LOCK is shown for approx. 5 seconds.
----------	--

3.14.2 EXIT – Return to operating level

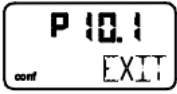

With this parameter you can leave the configuration level. The positioner returns to the operating level. Here you can either save data in the non-volatile memory or discard all Previously made changes (also the changes in other parameter groups).

To leave the configuration level (with or without saving), press and hold ENTER until the countdown from 3 to 0 is finished.

The active saving process is indicated by the message NV_SAVE. After saving a plausibility check is executed.

If an error occurs during the check or while saving, the data cannot be saved and an error message is displayed instead (see Chapter "Error codes").

NV_SAVE	Saves settings in the non-volatile memory.
CANCEL	Discards all changes made since the last permanent save operation.

3.15 Parameter group 11: Safe position



3.15.1 FAIL_POS – Safe position



This parameter must be used to activate the safe position prior to loading the factory settings (parameter FACT_SET) or changing the I/P module type (parameter IIP-TYP).

NOTE	
i	After setting parameters FACT_SET and IP-TYP as required, the safe position must be deactivated again manually.

The safe position that is activated (i.e., whether the actuator is ventilated or blocked) depends on the I/P module installed.

Activating / deactivating the safe position: Press and hold ENTER until the displayed countdown from 3 to 0 is finished. Then release ENTER. The safe position is activated or deactivated, respectively.

3.15.2 FACT_SET – Factory setting



You can use this parameter to reset the positioner to the factory setting. This is necessary, e.g., if an already configured positioner has to be installed on a different actuator and subsequently reconfigured.

CAUTION	
	<p>Risk of injury! For safety reasons, after loading the factory settings you must check whether the 1/P module type that is set matches the actual 1/P module type present in the device. Otherwise dangerous situations may occur when operating in control mode. It may happen that the actuator is driven at full speed to the end position .</p>

NOTE	
	<p>You can only load the factory settings when the actuator is in the safe position (parameter FAIL_POS). Otherwise, this action is inhibited and the message NO_F_POS is indicated in the display. If you save the settings in the non-volatile memory after loading the factory settings, operating mode 1.3 is automatically activated on the operating level.</p>

Load factory settings:

Press and hold ENTER until the displayed countdown from 3 to 0 is finished.

The positioner is reset to the factory settings. The message COMPLETE is displayed. Press ENTER to acknowledge the message.

FS_LOAD	Loads the factory settings
---------	----------------------------

3.15.3 IP-TYP – Type of the I/P module



Use this parameter to adapt the positioner software to the installed I/P module. This is required when installing a different I/P module type.

CAUTION	
	<p>Risk of injury! For safety reasons, after loading the factory settings you must check whether the 1/P module type that is set matches the actual 1/P module type present in the device. Otherwise dangerous situations may occur when operating in control mode. It may happen that the actuator is driven at full speed to the end position .</p>

CAUTION	
	<p>For safety reasons, after restoring the positioner to the factory settings you must check whether this parameter has been correctly set.</p>

3.15.4 IP_COMP – IP Compensation



This function is reserved for use by Spirax Sarco Service only.

3.15.5 HART_REV – HART version



As of firmware version 5, the positioner offers communication via both standard HART 5 and HART 7. To select, use the arrow keys UP or DOWN.

Squawk command:

A standardized HART-7 command causes the bottom menu line in the HMI of the addressed device to flash. This visual aid makes it easier to identify the addressed device in the system.

3.15.6 EXIT – Return to operating level



With this parameter you can leave the configuration level. The positioner returns to the operating level. Here you can either save data in the non-volatile memory or discard all Previously made changes (also the changes in other parameter groups).

To leave the configuration level (with or without saving), press and hold ENTER until the countdown from 3 to 0 is finished.

The active saving process is indicated by the message NV_SAVE. After saving a plausibility check is executed.

If an error occurs during the check or while saving, the data cannot be saved and an error message is displayed instead (see Chapter "Error codes").

NV_SAVE	Saves settings in the non-volatile memory.
CANCEL	Discards all changes made since the last permanent save operation.

3.16 Profibus PA and Foundation Fieldbus parameter descriptions (SP7-11, SP7-12 and SP7-21, SP7-22) - PROFIBUS PA and Foundation Fieldbus parameter

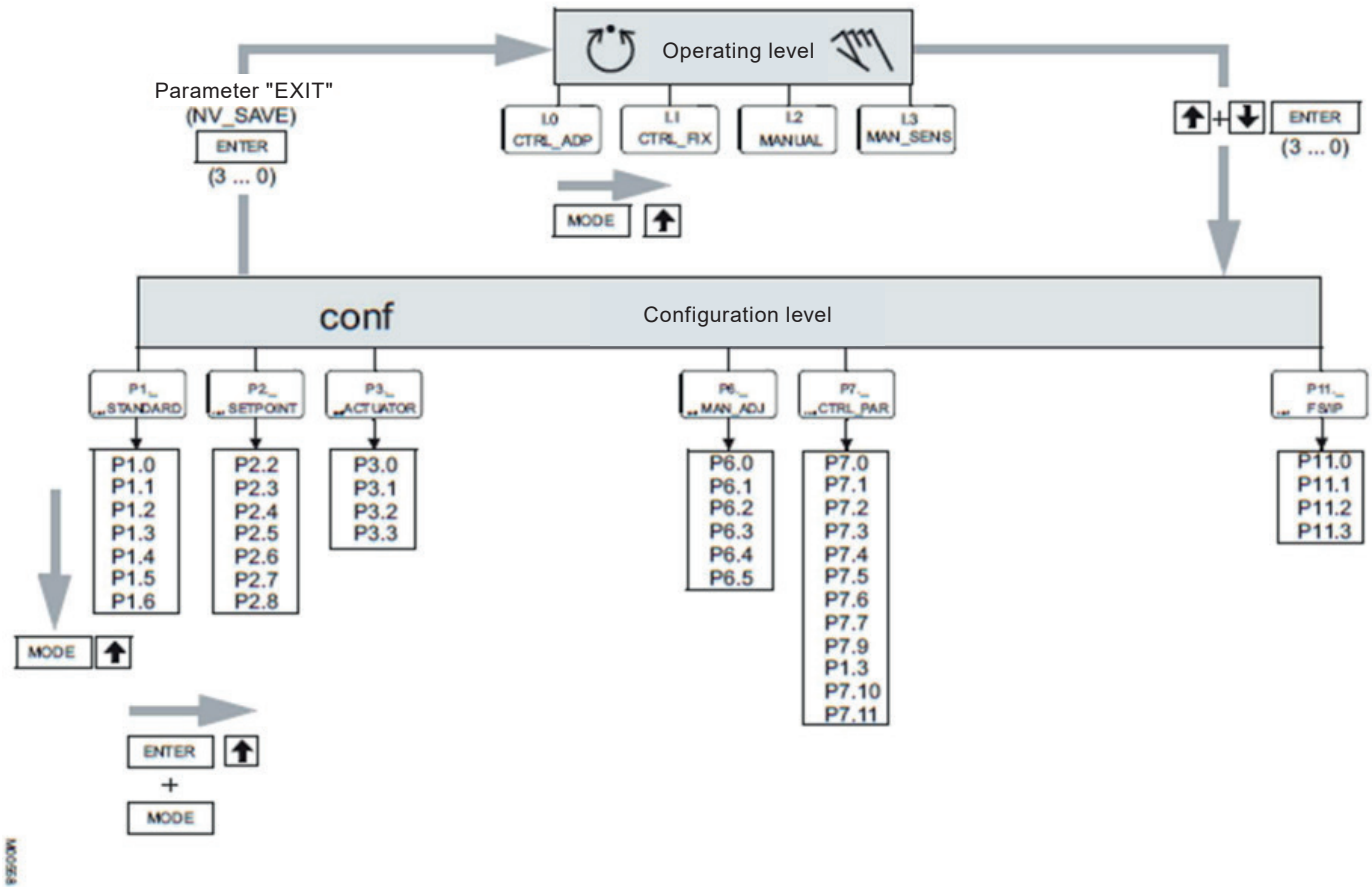

Parameter	Display	Function		Possible parameter setting	Unit	Factory setting
P1_	STANDARD					
P1.0	ACTUATOR	Actuator type	Actuator type	LINEAR, ROTARY	---	LINEAR
P1.1	AUTO_ADJ	Auto adjust	Autoadjust	Function	---	---
P1.2	TOL_BAND	Tolerance band (zone)	Tolerance band (zone)	0.3 ... 10.0	%	2.0
P1.3	DEADBAND	Deadband	Dead band	0.10 ... 10.00	%	0.20
P1.4	TEST	Test	Test	Function	---	INACTIVE
P1.5*	ADDRESS	Profibus Address	Set Address	3...125	---	3
P1.6	EXIT	Return	Return to operating level	Function	---	NV_SAVE

3.17 Profibus PA and Foundation Fieldbus parameter descriptions (SP7-11, SP7-12 and SP7-21, SP7-22)

Parameter	Display	Function		Possible parameter setting	Unit	Factory setting
P2._	SETPOINT					
P2.2	CHARACT	Charact. curve	Characteristic curve	LINEAR, 1:25, 1:50, 25:1, 50:1, USERD	---	LINEAR
P2.3	ACTION	Valve action	Effective direction	DIRECT, REVERSE	---	DIRECT
P2.4	SHUT_CLS	Shut-off value 0%	Shut-off value 0 %	OFF, 0.1 ... 45.0	%	1.0
P2.5	RAMP UP	Set point ramp up	Setpoint ramp (up)	OFF, 0 ... 200	---	OFF
P2.6	RAMP DN	Set point ramp down	Setpoint ramp (down)	OFF, 0 ... 200	---	OFF
P2.7	SHUT_OPN	Shut off value 100%	Shut-off value 100 %	55.0 ... 100.0, OFF	%	OFF
P2.8	EXIT	Return	Return to operating level	Function	---	NV_SAVE
P3._	ACTUATOR					
P3.0	MIN_RGE	Min. of stroke range	Operating range, min.	0.0 ... 90.0	%	0.0
P3.1	MAX_RGE	Max. of stroke range	Operating range, max.	100.0 ... 10.0	%	100
P3.2	ZERO_POS	Zero position	Zero position	CLOCKWISE, CTCLOCKWISE	---	CTCLOCKWISE
P3.3	EXIT	Return	Return to operating level	Function	---	NV_SAVE
P6._	MAN_ADJ					
P6.0	MIN_VR	Min. valve range	Operating range, min.	0.0 ... 100.0	%	0
P6.1	MAX_VR	Max. valve range	Operating range, max.	0.0 ... 100.0	%	100
P6.2	ACTUATOR	Actuator type	Actuator type	LINEAR, ROTARY	---	LINEAR
P6.3	SPRNG_Y2	Spring action (Y2)	Spring action (Y2)	CLOCKWISE, CTCLOCKWISE	---	CTCLOCKWISE
P6.5	EXIT	Return	Return to operating level	Function	---	NV_SAVE

Parameter	Display	Function		Possible parameter setting	Unit	Factory setting
P7._	CTRL_PAR					
P7.0	KP UP	KP value, up	KP value (up)	0.1 ... 120.0	---	5.0
P7.1	KP DN	KP value, down	KP value (down)	0.1 ... 120.0	---	5.0
P7.2	TV UP	TV value, up	TV value (up)	10 ... 450	---	200
P7.3	TV DN	TV value, down	TV value (down)	10 ... 450	---	200
P7.4	GOPULSE ^	Position offset, up	Position offset (up)	0...200		0
P7.5	GOPULSE v	Position offset, down	Position offset (down)	0...200		0
P7.6	Y-OFS UP	Y offset, up	Y offset (up)	0.0 ... 100.0	%	48.0
P7.7	Y-OFS DN	Y offset, down	Y offset (down)	0.0 ... 100.0	%	48.0
P7.9	TOL_BAND	Tolerance band (zone)	Tolerance band (zone)	0.3 ... 10.0	%	2.0
P1.3	DEADBAND	Deadband	Dead band	0.10 ... 10.00	%	0.20
P7.10	TEST	Test	Test	Function	---	INACTIVE
P7.11	EXIT	Return	Return to operating level	Function	---	NV_SAVE
P11._	FS / IP					
P11.0	FAIL_POS	Save position	Safe position	ACTIVE, INACTIVE	---	INACTIVE
P11.1	FACT_SET	Factory setting	Factory Setting	Function	---	NO_F_POS
P11.2	IP-TYP	I/P module type	Type of I/P module	NO_F_POS, F_SAFE_1, F_SAFE_2, F_FREEZE1, F_FREEZE2	---	[CUSTOM]
P11.3	EXIT	Return	Return to operating level	Function	---	NV_SAVE

* Only applies to PROFIBUS PA SP7-11 and SP7-21 units. Does NOT apply to Foundation Fieldbus SP7-12 or SP7-22.

3.18 Specific parameters for digital BUS communication versions only: - P1.5 ADDRESS – Bus Address (PROFIBUS PA version only)



This parameter is used to set the PROFIBUS address via which communication with the device takes place.

Important

Do not set addresses 1 or 2, as these are reserved for the master. Avoid assigning the same bus address to multiple devices. Input value: Recommended range: 3 ... 125

3.19 P7.4 GOPULSE^ Go pulse (up)



Important

All control parameters are determined in an optimum way for most actuators during Autoadjust. Changes should only be made when Autoadjust cannot be executed, or control stability cannot be achieved.

The positioner issues an amplified positioning signal for the defined pulse length and with the actuator not moving, in order to achieve accelerated starting of the actuator. This improves the dynamic; in particular, for small setpoint changes. To compensate for existing dissymmetry's in the controlled system, the go pulse should be set separately for both directions (up/down). If the actuator consistently overshoots the setpoint, decrease the go pulse. For small and fast actuators, it may be necessary to set the go pulse to 0, even if Autoadjust has determined a higher value.

Important

The value determined by Autoadjust should not be increased, as this may result in overshooting!

You can use parameter GOPULSE UP to move the go pulse for adjustment towards 100 %. Input value: In 20 ms increments

3.20 P7.5 GOPULSEv Go pulse (down)



Important

All control parameters are determined in an optimum way for most actuators during Autoadjust. Changes should only be made when Autoadjust cannot be executed, or control stability cannot be achieved.

The positioner issues an amplified positioning signal for the defined pulse length and with the actuator not moving, in order to achieve accelerated starting of the actuator. This improves the dynamic; in particular, for small setpoint changes. To compensate for existing dissymmetry in the controlled system, the go pulse should be set separately for both directions (up/down). If the actuator consistently overshoots the setpoint, decrease the go pulse. For small and fast actuators, it may be necessary to set the go pulse to 0, even if Autoadjust has determined a higher value.

Important

The value determined by Autoadjust should not be increased, as this may result in overshooting!

You can use parameter GOPULSE DN to move the go pulse for adjustment towards 0 %.

4. Diagnosis / error messages

4.1a Error codes

Error code	Possible cause	Impact	Troubleshooting the Instrument
<i>ERROR 10</i>	The supply voltage was interrupted for at least 20 ms. (This error is displayed after resetting the device to indicate the reason for the reset.)	-	Check the power source and the wiring.
<i>ERROR 11</i>	The supply voltage has fallen below the minimum voltage.	The actuator is moved to the safe position. After approx. 5 seconds, the positioner is automatically reset and starts up again with the message ERROR 10. If a local communication interface (LCI) is plugged in, the device will enter the operating mode LCI supply.	Check the power source and the wiring.
<i>ERROR 12</i>	The position is outside the measuring range. Possible reason is a malfunction in the position sensor.	In control mode: The actuator is moved to the safe position. On the configuration level: The output is set to neutral until a button is pressed. After approx. 5 seconds the positioner is automatically reset in control mode and on the configuration level.	Check the mounting.
<i>ERROR 13</i>	Invalid input current. This display indicates when the setpoint signal is overridden. The actuator is moved to the safe position.	-	Check the power source and the wiring.
<i>ERROR 20</i>	No access possible to the data in the EEPROM.	The actuator is moved to the safe position. After approx. 5 seconds, the positioner is automatically reset. Attempts are made to restore the data. This compensates for intermittent errors in the communication environment with the EEPROM.	If there is still no access to the EEPROM data after resetting the device, load the factory settings. If the error still persists, the device must be returned for repair to the manufacturer.

4.1a Error codes (continued)

Error code	Possible cause	Impact	Troubleshooting the Instrument
<i>ERROR 21</i>	Error while processing the measured values, pointing to an error in the working data (RAM).	The actuator is moved to the safe position. After approx. 5 seconds, the positioner is automatically reset and the RAM is reinitialized.	If the error persists even after the positioner has been reset, the device will need to be returned to the manufacturer for repair.
<i>ERROR 22</i>	Error during the table processing, pointing to an error in the working data (RAM).	The actuator is moved to the safe position. After approx. 5 seconds, the positioner is automatically reset and the RAM is reinitialized.	If the error persists even after the positioner has been reset, the device will need to be returned to the manufacturer for repair.
<i>ERROR 23</i>	Error when verifying the checksum of the configuration data (RAM).	The actuator is moved to the safe position. After approx. 5 seconds, the positioner is automatically reset and the RAM is reinitialized.	If the error persists even after the positioner has been reset, the device will need to be returned to the manufacturer for repair.
<i>ERROR 24</i>	Error in the processor function registers (RAM).	The actuator is moved to the safe position. After approx. 5 seconds, the positioner is automatically reset and the RAM is reinitialized.	If the error persists even after the positioner has been reset, the device will need to be returned to the manufacturer for repair.
<i>ERROR 50</i> . . . <i>ERROR 99</i>	Internal error.	The actuator is moved to the safe position. After approx. 5 seconds, the positioner is automatically reset.	If the error can be reproduced and occurs in the same position after resetting, the device must be returned for repair to the manufacturer.

4.1b Specific SP7-11/12 and SP7-21/22 Error messages:-

Error description	Error code
<p>Meaning: Defective memory chip</p> <p>Impact: Device does not boot up.</p> <p>Measure(s): Return the device for repair</p>	<i>NV_ERROR</i>
<p>Meaning: Auto adjust function lasts too long.</p> <p>Impact: Auto adjust function is aborted.</p> <p>Measure(s): Increase the supply pressure or use boosters.</p>	<i>TIMEOUT</i>
<p>Meaning: Mounting conditions not correct. Position outside sensor range.</p> <p>Impact: Auto adjust function is aborted.</p> <p>Measure(s): Check mounting conditions.</p>	<i>OUT_RANG</i>
<p>Meaning: a) Inconsistent data, e.g., low value > than high value, or incorrect configuration. b) Data cannot be saved locally, as PROFIBUS saves data in the background.</p> <p>Impact: a) Auto adjust function is aborted. b) Saving is not possible.</p> <p>Measure(s): a) Correct values or load factory settings b) Try again at a later point</p>	<i>CALC_ERR</i>

4.2 Alarm codes

Alarm code	Possible cause	Impact	Troubleshooting the Instrument
<i>ALARM 1</i>	Leakage between positioner and actuator	Depending on how well the leakage can be compensated, small control actions are required at regular intervals.	Check the piping.
<i>ALARM 2</i>	The setpoint current is outside the permissible range, i.e. it is < 3.8 mA or > 20.5 mA.	-	Check the power source.
<i>ALARM 3</i>	Alarm of the zero monitor. The zero position has shifted by more than 4%.	In control mode, a position outside the valve range can only be reached by driving to the limit stops, as the setpoint is limited to 0 ... 100%.	Correct the mounting.
<i>ALARM 4</i>	Controlling is inactive, because the device does not operate in control mode or the binary input is active.	The controller does not follow the setpoint.	Switch to control mode or switch off the binary input.
<i>ALARM 5</i>	Positioning timed out. The settling time needed exceeds the configured stroke time.	None, or adaptive control is performed (in adaptive mode).	Ensure that the actuator is not blocked. the supply air pressure is adequate. the given time limit is higher than 1.5 times the longest stroke time of the actuator. If adaption cannot run uninterruptedly for an actuator, adaption should be switched on until the alarm does not occur anymore during controlling actions.
<i>ALARM 6</i>	The defined limit value for the stroke counter has been exceeded.	-	Reset the counter (only possible via a connected PC with suitable software).
<i>ALARM 7</i>	The specified limit value for the travel counter has been exceeded.	-	Reset the counter (only possible via a connected PC with suitable software).

4.3 Message codes

Message codes	Message description
<i>BREAK</i>	Action stopped by operator.
<i>CALCERR</i>	Error during plausibility check.
<i>COMPLETE</i>	Action completed, acknowledgment required.
<i>EERR_ERR</i>	Memory error, data could not be saved.
<i>FAIL_POS</i>	Safe position is active, action cannot be executed.
<i>NO_F_POS</i>	Safe position required, but not active.
<i>NO_SCALE</i>	Valve range limits have not yet been determined; therefore, partial Autoadjust cannot be run.
<i>NV_SAVE</i>	Data is saved in the non-volatile memory.
<i>OUTOFRNG</i>	Measuring range is exceeded, Auto Adjust was automatically stopped.
<i>LOAD</i>	Data (factory settings) are being loaded.
<i>RNG_ERR</i>	Less than 10 % of the measuring range is used.
<i>RUN</i>	Action running.
<i>SIMUL</i>	Simulation has been started externally from a PC via HART, Protocol; switching outputs, alarm output and analog position feedback are no longer influenced by the process.
<i>SPR_ERR</i>	Actual spring action is different from the adjusted one.
<i>TIMEOUT</i>	Time-out; parameter could not be determined within two minutes; Autoadjust was automatically stopped.

4.4 Error handling

4.4.1 Positioner vibrates

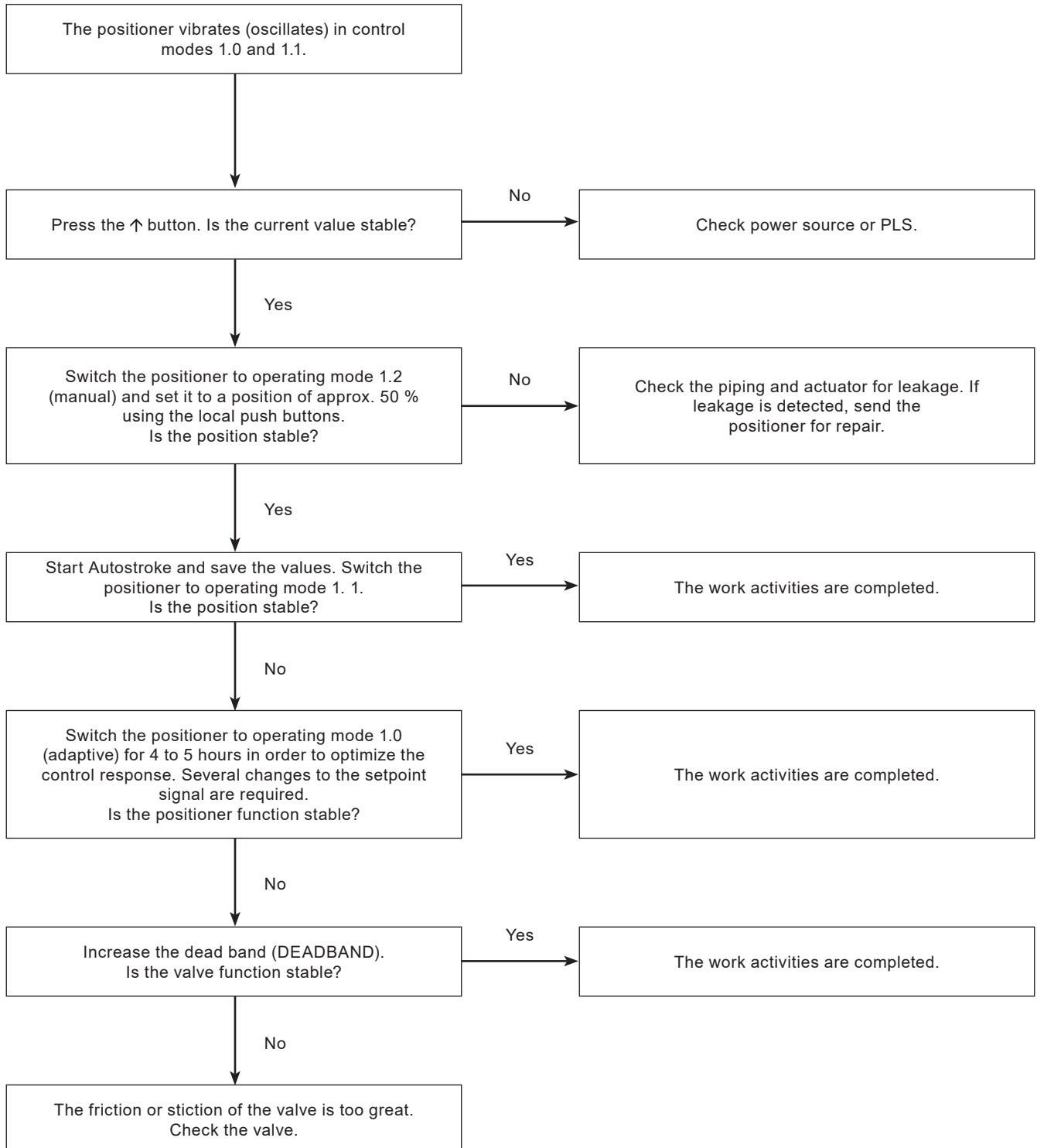

4.4.2 Positioner without function

