

**SND**  
**Spray Nozzle Desuperheater**  
Installation and Maintenance Instructions

---

---



1. Safety information
2. General product information
3. Inspection and performance confirmation
4. Installation
5. Operation
6. Maintenance
7. Troubleshooting

# 1. Safety information

Safe operation of these products can only be guaranteed if they are properly installed, commissioned, used and maintained by qualified personnel (see Section 1.11) in compliance with the operating instructions. General installation and safety instructions for pipeline and plant construction, as well as the proper use of tools and safety equipment must also be complied with.

## 1.1 Intended use

Referring to the Installation and Maintenance Instructions, name-plate and Technical Information Sheet, check that the product is suitable for the intended use/application.

The products listed below comply with the requirements of the European Pressure Equipment Directive 2014/68/EU and carry the  mark when so required.

The products fall within the Pressure Equipment Directive categories as shown below:

Application	Group 2 Gases	Group 2 Liquids
Steam	Will not exceed Cat. 3	-
Water	-	Will not exceed Cat. 2

- i) The products have been specifically designed for use on steam which is in Group 2 of the above mentioned Pressure Equipment Directive.
- ii) Check material suitability, pressure and temperature and the maximum and minimum design pressure and design temperature values on the product nameplate. If the maximum operating limits of the product are lower than those of the system in which it is being fitted, or if malfunction of the product could result in a dangerous overpressure or over-temperature occurrence, ensure a safety device is included in the system to prevent such over-limit situations.
- iii) Determine the correct installation situation and direction of fluid flow.
- iv) Spirax Sarco products are not intended to withstand external stresses that may be induced by any system to which they are fitted. It is the responsibility of the installer to consider these stresses and take adequate precautions to minimise them.
- v) Remove protective covers from all connections and protective film from all name-plates, where appropriate, before installation on steam and water lines.

## 1.2 Access

Ensure safe access and if necessary a safe working platform (suitably guarded) before attempting to work on the product. Arrange suitable lifting gear if required.

## 1.3 Lighting

Ensure adequate lighting, particularly where detailed or intricate work is required.

## 1.4 Hazardous liquids or gases in the pipeline

Consider what is in the pipeline or what may have been in the pipeline at some previous time. Consider: flammable materials, substances hazardous to health, extremes of temperature.

## 1.5 Hazardous environment around the product

Consider: explosion risk areas, lack of oxygen (e.g. tanks, pits), dangerous gases, extremes of temperature, hot surfaces, fire hazard (e.g. during welding), excessive noise, moving machinery.

## 1.6 The system

Consider the effect on the complete system of the work proposed. Will any proposed action (e.g. closing isolation valves, electrical isolation) put any other part of the system or any personnel at risk?

Dangers might include isolation of vents or protective devices or the rendering ineffective of controls or alarms. Ensure isolation valves are turned on and off in a gradual way to avoid system shocks.

## 1.7 Pressure systems

Ensure that any pressure is isolated and safely vented to atmospheric pressure. Consider double isolation (double block and bleed) and the locking or labelling of closed valves. Do not assume that the system has depressurised even when the pressure gauge indicates zero.

## 1.8 Temperature

Allow time for temperature to normalise after isolation to avoid danger of burns.

## 1.9 Tools and consumables

Before starting work ensure that you have suitable tools and/or consumables available. Use only genuine Spirax Sarco replacement parts.

## 1.10 Protective clothing

Consider whether you and/or others in the vicinity require any protective clothing to protect against the hazards of, for example, chemicals, high/low temperature, radiation, noise, falling objects, and dangers to eyes and face.

## 1.11 Permits to work

All work must be carried out or be supervised by a suitably competent person.

Installation and operating personnel should be trained in the correct use of the product according to the Installation and Maintenance Instructions.

Where a formal 'permit to work' system is in force it must be complied with. Where there is no such system, it is recommended that a responsible person should know what work is going on and, where necessary, arrange to have an assistant whose primary responsibility is safety.

Post warning notices if necessary.

## 1.12 Handling

Manual handling of large and/or heavy products may present a risk of injury. Lifting, pushing, pulling, carrying or supporting a load by bodily force can cause injury particularly to the back. You are advised to assess the risks taking into account the task, the individual, the load and the working environment and use the appropriate handling method depending on the circumstances of the work being done.

## 1.13 Residual hazards

In normal use the external surface of the product may be very hot. If used at the maximum permitted operating conditions the surface temperature of some products may reach temperatures of 590 °C (1094 °F).

Many products are not self-draining. Take due care when dismantling or removing the product from an installation (refer to 'Maintenance instructions').

## 1.14 Freezing

Provision must be made to protect products which are not self-draining against frost damage in environments where they may be exposed to temperatures below freezing point.

## 1.15 Disposal

Unless otherwise stated in the Installation and Maintenance Instructions, this product is recyclable and no ecological hazard is anticipated with its disposal providing due care is taken.

Please visit the Spirax Sarco product compliance web pages

<https://www.spiraxsarco.com/product-compliance>

for up to date information on any substances of concern that may be contained within this product. Where no additional information is provided on the Spirax Sarco product compliance web page, this product may be safely recycled and/or disposed providing due care is taken. Always check your local recycling and disposal regulations.

## 1.16 Returning products

Customers and stockists are reminded that under EC Health, Safety and Environment Law, when returning products to Spirax Sarco they must provide information on any hazards and the precautions to be taken due to contamination residues or mechanical damage which may present a health, safety or environmental risk. This information must be provided in writing including Health and Safety data sheets relating to any substances identified as hazardous or potentially hazardous.

## 2. General product information

### 2.1 General

This document presents the installation, operation and maintenance instructions for spray nozzle desuperheaters - SND.

This document should be read with the general arrangement drawing of the desuperheater.

The SND only comprises a cooling water branch, a cooling water inlet flange, a mounting flange, a nozzle holder and a spray nozzle. The spray nozzle is screwed then seal welded into a nozzle holder. The purpose of the seal weld is to prevent them becoming unscrewed during operation.

Direct contact desuperheaters reduce the temperature of superheated steam to produce steam temperatures approaching saturation temperature (typically to within 3°C of the saturation temperature). To cool the superheated steam a medium; usually water, is entrained and flashed into vapour by absorbing heat from the steam.

They contain no moving parts and are therefore very simple in operation.



Fig. 1 SND spray nozzle desuperheater

## 2.2 Construction

Fig. 2

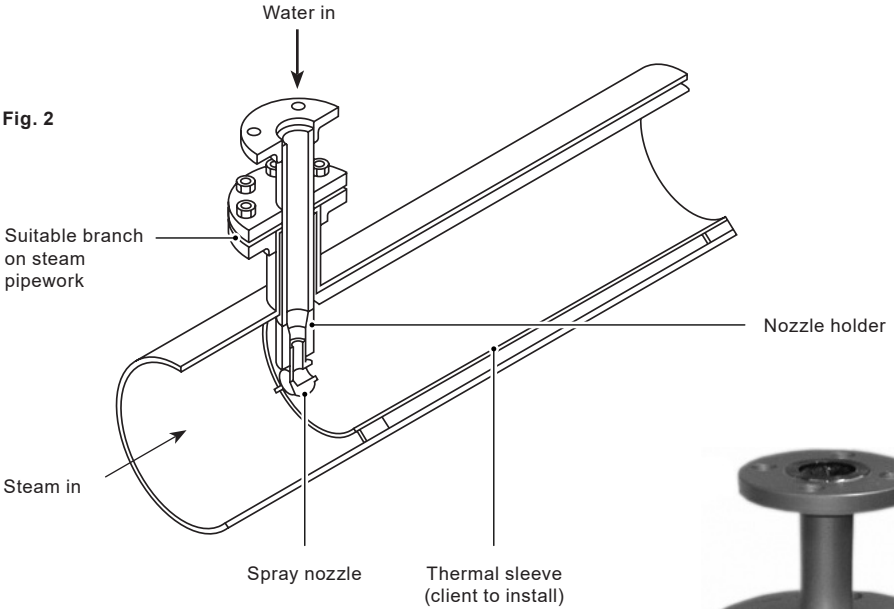

Fig. 3

The spray nozzle desuperheater, type SND is an assembly which comprises one or more spray nozzles, cooling water inlet pipe, counter flange and cooling water inlet flange. The counter flange allows others to fit the SND onto a flanged branch in the steam pipework.

Usually, only one spray nozzle is installed, but in large units (bigger than 20" NB), a number of spray nozzles may be employed to provide better water coverage across the cross sectional area of the pipe. Such an arrangement is shown on the adjacent page. The spray nozzles are positioned to spray at different angles to the steam flow to 'cover' as much of the pipe cross sectional area as possible.

The spray nozzle(s) is/are screwed then seal welded into a nozzle holder. The purpose of the seal weld is to prevent them becoming unscrewed during operation.

Details of the pipework such as size, thickness and branch size, flange rating and stand-out dimension have to be provided by the customer so we can ensure that once installed, the spray nozzle(s) is/are correctly located within the steam pipe.

For reasons stated below, we strongly advise that a thermal sleeve is installed by others.

An SND is effectively a spray type desuperheater (Type STD), but without the shell and thermal sleeve.

## 2.3 Materials of construction

Component	Mechanical design temperature up to and including 425 °C	Mechanical design temperature above 425 °C up to and including 590°C
Pipe	ASTM A106 GrB	ASTM A335 P11
Flanges	ASTM A105N	ASTM A182 F11
Spray nozzle	ASTM A182 F316L	ASTM A182 F11
Nozzle holder	ASTM A350 LF2N	ASTM A182 F11

## 2.4 Typical SND multi-nozzle arrangement

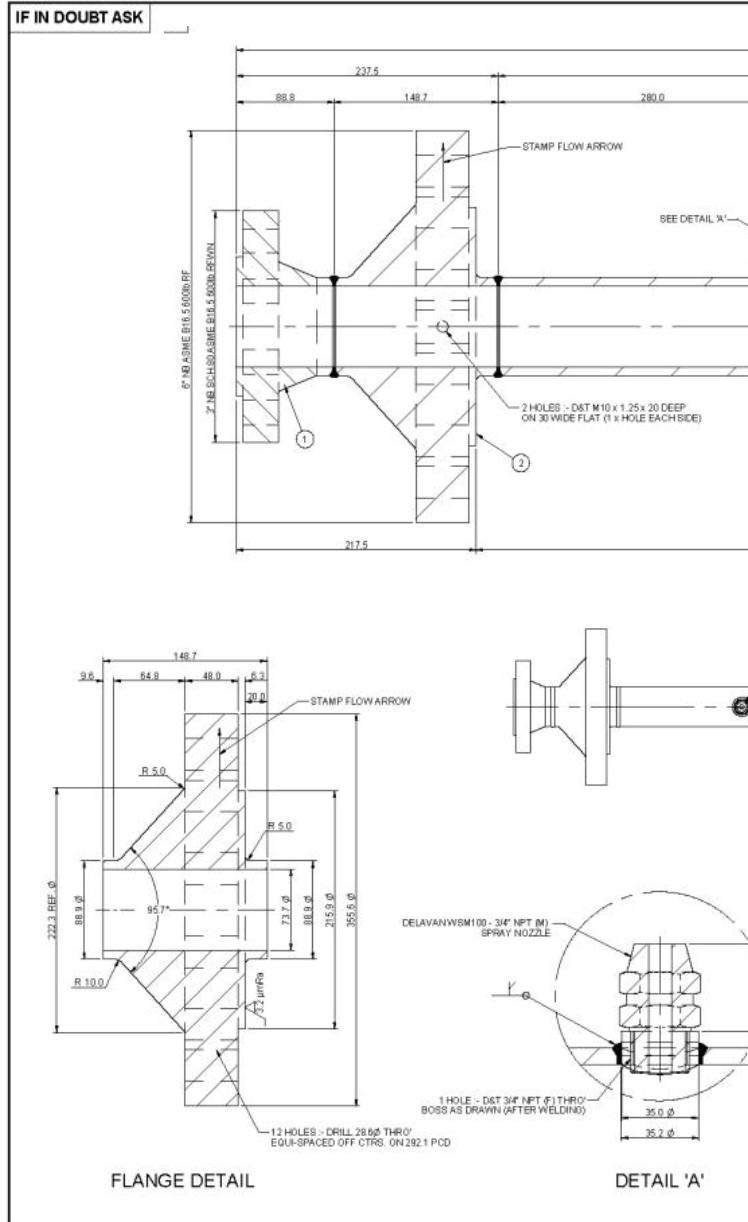

SND Spray Nozzle Desuperheater





## 3. Inspection and performance confirmation

### 3.1 Receiving inspection

Although Spirax Sarco carries out full inspection of all Units before despatch, damage may have occurred during transit. On receipt of the unit, a visual inspection will highlight any external damage and hence indicate any internal damage that may have occurred. If this is the case please contact us immediately.

### 3.2 User's rating inspection

Before installing the SND, the user must ensure the mechanical rating of the unit is suitable for the intended service.

Details of the mechanical rating can be found on the nameplate and associated documentation for the unit.

# 4. Installation

**Note: Please read Section 1, 'Safety information' before proceeding with installation.**

## 4.1 General

It is important that installation should only be carried out by qualified, experienced personnel, who are familiar with the fitting of spray nozzle desuperheaters, and who have read and understood the instructions in this IM.

## 4.2 Installation considerations

### 4.2.1 Thermal sleeve

We strongly recommend that a thermal sleeve is installed in the steam line.

The purpose of the thermal sleeve is three-fold:

- The thermal sleeve allows circulation of superheated steam through the annular area between the outside of the sleeve and the inside diameter of the shell. This arrangement heats the thermal sleeve and provides a hot surface on which serves to assist the evaporation of the water droplets. It aids operation of the SND at the bottom of its operating range when the spray pattern of the nozzle is not at its most efficient.
- It protects the pipe from erosion due to the impingement of the sprayed water droplets and
- It prevents local thermal shock (and possible subsequent stress corrosion) in the pipe wall where the cold water would otherwise impinge on the hot pipe.

The thermal sleeve shall be located such that the spray of water droplets is directed towards it. The spray angle of the spray nozzles used in SND design is 70 degrees inclusive angle.

At mechanical design temperatures up to and including 425°C, we recommend the use of sch10 stainless steel for the thermal sleeve. Between 425°C and 590°C, we recommend Cr-Mo steel, grade 11 at schedule 40 or standard wall thickness. At steam line sizes up to and including 20" NB, we recommend the thermal sleeve is manufactured from pipe which is one size smaller than the steam line. Above 20" NB steam line size, we recommend the thermal sleeve is two sizes smaller.

### 4.2.2 Steam piping upstream of the desuperheater

- a) Where noise from a PRV is expected to be a problem, consider making this pipe thicker than that required to just contain the pressure. This will help reduce noise levels emitted to atmosphere. Under extreme conditions this pipe may have to be acoustically insulated. This, however is very rare indeed.
- b) The distance between the PRV and inlet to the SND should be as short as possible but long enough to have eliminated valve turbulence at the inlet to the desuperheater. The rule of thumb is that this distance should be five times the diameter of the desuperheater inlet or 1.5 metres, whichever is the longer. If the PRV and desuperheater are too close or if the PRV is too close to a pipe bend or other fitting, then turbulence may cause noise and vibration.

### 4.2.3 Discharge steam piping

- a) The distance between the desuperheater discharge connection and the location of the temperature sensor must be long enough to allow complete evaporation of the cooling water ahead of the sensor. If the sensor is too close to the desuperheater discharge, evaporation of the cooling water will not be complete and the sensor will give a false reading, with corresponding poor temperature control.
- b) This pipe should be straight, free of bends and contain no restrictions. We recommend a minimum straight length distance of 2.5 to 7.5 m depending on the amount of residual superheat required (specified in table below). The greater the amount of residual superheat required, the faster the water droplets are evaporated and the shorter the distance required.
- c) The table below specifies the minimum straight distance required between the desuperheater outlet and the temperature sensor versus residual superheat.

Amount of residual superheat	Minimum straight length distance to temperature sensor
3 - 5°C	7.50 m
10°C	6.80 m
15°C	6.25 m
30°C	5.00 m
50°C	3.70 m
100°C	2.50 m

- d) If bends or restrictions are placed in this pipework within the specified distance, before the droplets have had chance to evaporate, inertia causes the droplets to separate out from the main steam flow and run along the bottom or side wall of the pipe. Contact between the steam and cooling water is lost and desuperheating is halted.
- e) Use thermal insulation over this pipe section to help prevent false temperature readings (condensation can still occur on the walls of a 50°C superheated steam line). Measurement error can be quite large, especially at low flow rates when heat lost through condensation is a high percentage of total heat energy in the line.

### 4.2.4 Temperature sensor

- a) Speed of controlled response is important. For this reason, thermocouples or resistance thermometers are usually employed.
- b) The size of an associated thermowell is important. Ones with large mass slow down rate of heat transfer and can cause serious measurement time lags. At low flow rates the problem is worse. Sometimes it's sufficient to simply improve contact between the sensor and well. But in other cases a special well may be needed, such as an extended-surface type. Recommendations should be sought from the instrument supplier.
- c) The temperature sensor should be positioned on the uppermost surface of a horizontal installation.

#### **4.2.5 Pressure sensor**

This should be located at a minimum distance of 1.5 metres away from the desuperheater discharge flange. Ideally however, this should be located at the point of use so that the pressure control valve can compensate for any line loss between the desuperheater and the point of use.

#### **4.2.6 Pressure relief valve (PSV)**

In applications involving simultaneous pressure reduction and depending upon the pressure rating of the equipment, a safety relief valve to protect both the Desuperheater and downstream equipment from the effects of excess pressure shall be considered. This could protect the Desuperheater and downstream equipment if the PRV failed fully open for example.

#### **4.2.7 Installation orientation**

Spray nozzle desuperheaters may be installed with the steam flowing either horizontally or vertically upwards.

Spirax Sarco strongly advises against an installation in which the steam flow is vertically downwards.

The branch to which the SND is fitted is usually on the top of the steam line. It may also be located on the side. We would recommend against having the branch at the bottom of the steam line as this would provide an area where hot condensate could collect. This condensate could present a hazard when removing the SND from the line.

## 4.2.8 Other installation considerations

### a) Isolation valves:

To provide a shut-off facility and to allow maintenance to be carried out, isolation valves are recommended upstream of:

- The superheated steam pressure control valve.
- The cooling water control valve.

### b) Strainers: Depending on steam and cooling water quality, consider installing strainers in the lines in order to protect both the cooling water and steam valves as well as to prevent the small bores within the Desuperheater from becoming blocked.

### c) Separator station: In applications where there must be no moisture in the resulting steam (such as steam supply to a turbine or motive steam supply to a thermocompressor for example) it is recommended that a separator is installed downstream of the Desuperheater system. This will protect downstream pipework and equipment from the effects of moisture in the event of a control system failure or from abnormal operating conditions, such as at start-up for example.

It is also considered prudent to install a separator station when desuperheating close to saturation temperature or for applications involving large steam turndowns. The separator must be located after the temperature sensor thereby giving the water droplets as much time as possible to evaporate.

The associated steam trap should be selected to prevent air binding and the discharge pipe from the steam trap should have ample capacity to deal with the drainage and be installed as near to the vertical as possible. There must be sufficient space in the drainpipe for the water to flow down and the air to pass up the pipe.

### d) Non Return Valve (NRV): Consider the installation of an NRV in the cooling water line located immediately before the cooling water inlet connection to prevent back flow of steam into the cooling water inlet line in the event of either cooling water failure or excess pressure in the Desuperheater caused by failure of the steam pressure reducing valve for example.

### e) Pressure tappings: Include plugged pressure tappings within the connecting pipework which would allow gauges to be fitted to assist troubleshooting in the event of operational problems.

### f) All connecting pipework must be sized in accordance with good working practice.

### g) The termination points of the Spray Nozzle Desuperheater are not designed to be load bearing, therefore the client is responsible for ensuring that pipework loads are not transmitted to the connecting flanges of the Desuperheater. We recommend that connecting pipework is supported from adjacent steelwork, to prevent loads being transmitted to the Desuperheater.

### h) Gaskets, valves, cocks and any in-line Instruments should not reduce the cross sectional area of the connecting pipelines. This is of particular importance in smaller bore pipework.

### i) Ensure that low points of all interconnecting pipework have suitable connections for drains.

### j) Ensure the system can be safely vented back to atmospheric pressure following a shut down.

### k) Consider the installation of air vents to remove air on start-up.

## 4.3 Unit installation

### 4.3.1 Pre-installation check

- a) The gasket materials used for the installation must be compatible with the fluids passing through the desuperheater and must be suitable for the design conditions of the installation.
- b) Ensure that the connecting pipelines are clean and that all weld spatter and foreign bodies have been removed.
- c) Ensure the desuperheater is free of foreign bodies such as packing materials etc.

### 4.3.2 Installation

Only two connections into the connecting pipework are required.

Firstly, insert the cooling water branch of the SND through the branch on the steam line, orientate the spray nozzles to discharge in the same direction as the steam flow, and bolt-up the flanged connection between the steam line branch and the mounting branch on the SND.

Secondly, connect the cooling water supply line to the cooling water connection on the SND.

# 5. Operation

## 5.1 Unit operation

It contains no moving parts and is therefore very simple in operation.

The incoming cooling water is atomised by a spray nozzle which has a fixed diameter. It is usually located on the centre-line of the SND and is arranged to face downstream. i.e.: It sprays in the same direction as the steam flow. The spray nozzle forms a 'hollow-cone' spray pattern at a spray angle of around 70°.

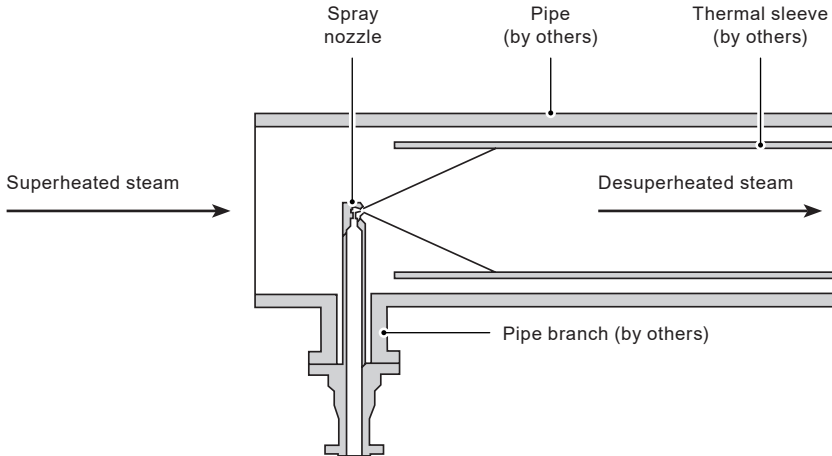

Fig. 4 SND spray nozzle desuperheater

The spray of droplets is directed towards a thermal sleeve which is fitted into the steam pipe by others. The thermal sleeve allows circulation of superheated steam through the annular area between the outside of the sleeve and the inside diameter of the shell. This arrangement heats the thermal sleeve and provides a hot surface on which serves to assist the evaporation of the water droplets.

The thermal sleeve also serves to protect the pipe in two ways. Firstly it protects the pipe from erosion due to the impingement of the sprayed water droplets and secondly it prevents local thermal shock (and possible subsequent stress corrosion) in the pipe wall where the cold water would otherwise impinge on the hot pipe.

The incorporation of a thermal sleeve also aids operation at the bottom of its operating range when the spray pattern of the nozzle is not at its most efficient.

As there is very little restriction to the steam flow, there is no steam pressure drop across an SND.



## 5.2 Pre-operational check

- a) Check control system has been tested and is operational.
- b) Check relief valve (if fitted) has been tested and is fit for operation.
- c) Ensure all isolation valves (both steam and cooling water) are closed.
- d) Ensure that all line restrictions have been removed.
- e) Ensure that cooling water is available upstream of the cooling water isolation valve.
- f) Take all precautions necessary to handle the possibility of leakage, both in terms of protection of personnel and nearby equipment.

## 5.3 Start-up procedure

The following start-up procedure should be considered as our initial recommendation as to how to start-up the Desuperheater. It must be reviewed by the end user, preferably within a HAZOP, to determine whether it is consistent with the operating philosophy of the rest of the plant. The sequence of steps can be revised if necessary. However, the approach of ensuring the cooling water is made available to the desuperheater before admitting steam must be followed.

1. Activate the control system. The temperature control valve in the cooling water inlet line should close.
2. Open the cooling water isolation valve.
3. Open the steam isolation valve downstream the desuperheater. This may cause the Desuperheater to pressurise, depending on the condition of the downstream system.
4. Very slowly open the upstream steam isolation valve to admit superheated steam to the desuperheater. Steam will begin to flow through the desuperheater. The PRV (if fitted) will begin to modulate to control the downstream pressure and the cooling water control valve will begin to open.
5. At this point the desuperheater is fully operational. Operational checks should be made to ensure:-
  - The cooling water valve is modulating correctly.
  - The PRV (if fitted) is modulating correctly.
  - The control valves are neither fully open nor nearly shut. (This would indicate incorrect sizing of these items).
  - The pressures of all streams around the desuperheater are correct.
  - The desired desuperheated temperature is being met.
  - All other ancillary items related to the desuperheater operation are functioning satisfactorily.

## 5.4 Shutdown procedure

This procedure must be reviewed and checked for consistency of operation with the rest of the plant. The sequence of steps may be revised if necessary, but the general principle of isolating the cooling water as the last step must be followed.

1. Slowly close the upstream steam isolation valve.
2. Close the isolation valve downstream the desuperheater.
3. Close the cooling water isolation valve.

De-activate the control system

**The desuperheater is now shut down.**

---

SND Spray Nozzle Desuperheater

**spirax**  
**sarco**

# 6. Maintenance

**Note: Please read Section 1, 'Safety information' before proceeding with any maintenance.**

Maintenance should only be carried out by qualified, experienced personnel, who are familiar with desuperheaters and who have read and understood all the instructions in this document.

## Caution

**Do not proceed with any maintenance unless the venturi type desuperheater has:-**

- i. Been relieved of all pressure and/or vacuum.
- ii. Been allowed to reach ambient temperatures.
- iii. Been drained and purged of all fluids.
- iv. Had all connecting lines fully isolated.

## 6.1 Preventative maintenance

Spirax Sarco suggests that the user creates maintenance schedules, safety manuals and inspection schedules for each specific desuperheater installation.

On all installations, the following items should be considered by the user :-

- a) Desuperheater for blockages, particularly the cooling water nozzle. Check spray nozzle for scale build up which could indicate poor cooling water quality.
- b) Desuperheater for internal wear, particularly the spray nozzle.
- c) Discharge piping and fittings for signs of erosion, corrosion, debris build up and blockages.
- d) Sufficient tightness of flange connecting bolts.
- e) Strainers for debris build up.
- f) All other associated ancillary equipment and valves, in particular:-
  - The correct operation of all control equipment.
  - The correct operation of instrumentation.

## 6.2 Maintenance of spray nozzle desuperheaters

The SND only comprises a cooling water branch, a cooling water inlet flange, a mounting flange, a nozzle holder and a spray nozzle. The spray nozzle is screwed then seal welded into a nozzle holder. The purpose of the seal weld is to prevent them becoming unscrewed during operation.

Thus, the SND is of a completely fabricated construction, incapable of being disassembled into its component parts. There are no removable components.

Inspection is therefore limited to a visual inspection once it has been removed from the steam line.

# 7. Troubleshooting

**Note: Please read Section 1, 'Safety information' before troubleshooting.**

## 7.1 Introduction

Once successfully commissioned, desuperheaters provide trouble free service. However, as with any equipment in erosive or corrosive service, break down beyond control may occur.

A knowledge of the correct procedures for locating and correcting faults can lead to considerable time saving.

Poor performance of a desuperheater can be caused by either external or internal factors. Secondly, all performance can also be classified as either being gradual or sudden.

In general, a gradual loss of performance will normally suggest internal corrosion or erosion, whereas a sudden loss in performance will normally suggest an external factor is to blame.

Before setting out to examine why the desuperheater is not performing correctly, we strongly recommend that all instruments and any Control Systems are first checked that they are not giving false readings.

## 7.2 External causes of poor performance

At this stage, if an actual control system is fitted, ensure that all pressure and temperature indicating controllers are functioning and set correctly. Also check supply and signal pneumatic or electrical lines to the respective actuated control valve. Then check the operation of both the pressure and temperature control valves.

### i.) Outlet pressure not in accordance with the specification.

- a) Check the operation of the actuated or manually operated pressure control valve, prior to the Desuperheater.
- b) Check the steam pressure upstream and downstream of the pressure control valve. The superheated steam at the inlet to the desuperheater must be in accordance with the design specification or the design of the unit must be modified.
- c) A varying steam pressure will cause a fluctuating outlet steam pressure unless an actuated pressure control system is fitted.

### ii.) Steam outlet temperature not in accordance with the specification.

- a) Check temperature and pressure of cooling water prior to unit is in accordance with the design specification. If the pressure and temperature cannot be changed in accordance with the design specification, the desuperheater must be modified.
- b) Check all ancillary equipment associated with the cooling water supply line, including possible booster pumps, strainers, non - return valves and manually operated and actuated temperature control valves and associated control system.
- c) Check the atomising steam pressure and temperature is within specification.

## 7.3 Internal causes of poor performance

Due to the simple construction of SNDs, the only internal problems are associated with the cooling water spray nozzle. The problems encountered are:

- Blocked or partially blocked spray nozzle due to presence of foreign body.
- Blocked or partially blocked spray nozzle due to scaling, which in turn is due to poor cooling water quality.
- Excessive wear within spray nozzle. (Very rare).

