

SLM1, SLM2, SLI1 and SLI2 Limit Switches

Installation and Maintenance Instructions

SLM1
shown on
a typical
valve /
actuator
assembly

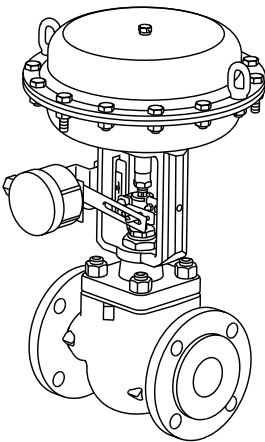

1. Safety information
2. General product information
3. Installation and commissioning

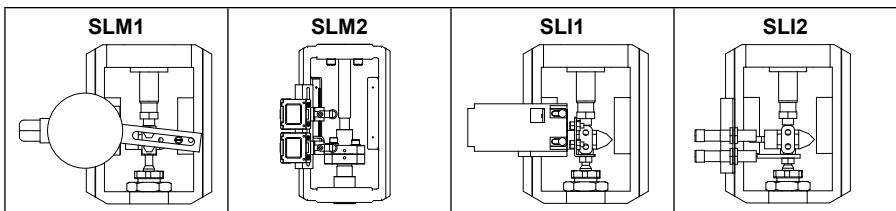

1. Safety information

Safe operation of these products can only be guaranteed if they are properly installed, commissioned, used and maintained by qualified personnel (see Section 1.11) in compliance with the operating instructions. General installation and safety instructions for pipeline and plant construction, as well as the proper use of tools and safety equipment must also be complied with.

Note:

This document refers only to the mechanical installation and commissioning of the SLM1, SLM2, SLI1 and SLI2 limit switches and should be used in conjunction with the relevant IMIs for the control valve and actuator that they are being connected to.

Warning

These limit switches have been designed and constructed to withstand the forces encountered during normal use.

Use of these products for any other purpose, or failure to install them in accordance with these Installation and Maintenance Instructions, could cause damage to the product, will invalidate the CE marking, and may cause injury or fatality to personnel.

Before any installation or maintenance procedure, always ensure that all primary steam and condensate return lines and secondary water lines are isolated.

Ensure any residual internal pressure in the system or connecting pipework is carefully relieved.

Allow hot parts to cool before commencing work, to avoid the risk of burns.

Always wear appropriate safety clothing before carrying out any installation or maintenance work.

1.1 Intended use

Referring to the Installation and Maintenance Instructions, name-plate and Technical Information Sheet, check that the product is suitable for the intended use/application. These limit switches comply with the requirements of the European Pressure Equipment Directive 97/23/EC and carry the CE mark when so required. It should be noted that products that fall within Category 'SEP' of the PED are required by the directive not to carry the CE mark.

- i) Check that the limit switch is correct for the intended application. If there is any uncertainty contact Spirax Sarco to confirm the suitability of the product for the application being considered.
- ii) Check material and product suitability, pressure, temperature, voltage, current, power, IP and their maximum and minimum values. If the maximum operating limits of the product are lower than those of the system in which it is being fitted, or if malfunction of the product could result in a dangerous overpressure or overtemperature occurrence, ensure a safety device is included in the system to prevent such over-limit situations.
- iii) Determine the correct installation situation and correct electrical polarity of wiring.
- iv) Spirax Sarco products are not intended to withstand external stresses that may be induced by any system to which they are fitted. It is the responsibility of the installer to consider these stresses and take adequate precautions to minimise them.
- v) Remove protection covers from all connections and protective film from all name-plates, where appropriate, before installation on steam or other high temperature applications.

1.2 Access

Ensure safe access and if necessary a safe working platform (suitably guarded) before attempting to work on the product. Arrange suitable lifting gear if required.

1.3 Lighting

Ensure adequate lighting, particularly where detailed or intricate work is required.

1.4 Hazardous liquids or gases in the pipeline

Consider what is in the pipeline or what may have been in the pipeline at some previous time. Consider: flammable materials, substances hazardous to health, extremes of temperature.

1.5 Hazardous environment around the product

Consider: explosion risk areas, lack of oxygen (e.g. tanks, pits), dangerous gases, extremes of temperature, hot surfaces, fire hazard (e.g. during welding), excessive noise, moving machinery.

1.6 The system

Consider the effect on the complete system of the work proposed. Will any proposed action (e.g. closing isolation valves, electrical isolation) put any other part of the system or any personnel at risk?

Dangers might include isolation of vents or protective devices or the rendering ineffective of controls or alarms. Ensure isolation valves are turned on and off in a gradual way to avoid system shocks.

1.7 Pressure systems

Ensure that any pressure is isolated and safely vented to atmospheric pressure. Consider double isolation (double block and bleed) and the locking or labelling of closed valves. Do not assume that the system has depressurised even when the pressure gauge indicates zero.

1.8 Temperature

Allow time for temperature to normalise after isolation to avoid danger of burns.

1.9 Tools and consumables

Before starting work ensure that you have suitable tools and/or consumables available. Use only genuine Spirax Sarco replacement parts.

1.10 Protective clothing

Consider whether you and/or others in the vicinity require any protective clothing to protect against the hazards of, for example, chemicals, high/low temperature, radiation, noise, falling objects, and dangers to eyes and face.

1.11 Permits to work:

- All work must be carried out or be supervised by a suitably competent person.
- Installation and operating personnel should be trained in the correct use of the product according to the Installation and Maintenance Instructions.
- Where a formal 'permit to work' system is in force it must be complied with. Where there is no such system, it is recommended that a responsible person should know what work is going on and, where necessary, arrange to have an assistant whose primary responsibility is safety.
- Post 'warning notices' if necessary.

1.12 Handling

Manual handling of large and/or heavy products may present a risk of injury. Lifting, pushing, pulling, carrying or supporting a load by bodily force can cause injury particularly to the back. You are advised to assess the risks taking into account the task, the individual, the load and the working environment and use the appropriate handling method depending on the circumstances of the work being done.

1.13 Residual hazards

In normal use the external surface of the surrounding system may be very hot. If used at the maximum permitted operating conditions the surface temperature of some products may reach temperatures of 300°C (572°F).

Many products are not self-draining. Take due care when dismantling or removing the product from an installation (refer to 'Maintenance instructions').

1.14 Freezing

Provision must be made to protect products which are not self-draining against frost damage in environments where they may be exposed to temperatures below freezing point.

1.15 Disposal

Unless otherwise stated in the Installation and Maintenance Instructions, this product is recyclable and no ecological hazard is anticipated with its disposal providing due care is taken.

1.16 Returning products

Customers and stockists are reminded that under EC Health, Safety and Environment Law, when returning products to Spirax Sarco they must provide information on any hazards and the precautions to be taken due to contamination residues or mechanical damage which may present a health, safety or environmental risk. This information must be provided in writing including Health and Safety data sheets relating to any substances identified as hazardous or potentially hazardous.

2. General product information

2.1 Description

The switch kits are for use with linear pneumatic actuators conforming to the NAMUR standard. The series provides mechanical and inductive switched electric signals, relative to the actuator position.

2.2 Applications and technical data

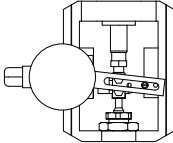
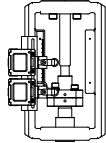
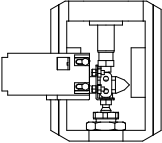
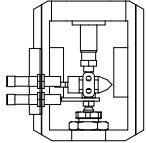
Limit switches	SLM1	SLM2	SLI1	SLI2
				
	This switch consists of two mechanical micro-switches within a single unit to provide valve actuator position (open / close) after setting.	This switch consists of two mechanical micro-switch units to provide valve actuator position (open / close) after setting.	This switch consists of two proximity sensors within a single unit to provide valve actuator position (open / close) after setting.	This switch consists of two proximity sensors to provide valve actuator position (open / close) after setting
	See Section 3.1	See Section 3.2	See Section 3.3	See Section 3.4
Operation and type	2 sensors within the unit Contact, Mechanical	1 independant sensor Contact, Mechanical	2 sensors within the unit No contact, proximity (inductive)	1 independant sensor No contact, proximity (inductive)
Max. voltage and current	ac	250 Vac 16 A	24 Vac 6 A to 250 Vac 3 A	0.1 A
	dc	48 Vdc 16 A	12 Vdc 10 A to 230 Vdc 5 A	30 Vdc
Standards	IP65	IP66	IP68 and ATEX	IP67 and ATEX
Temperature limit	-20° to +85°C	-25° to +70°C	-25° to +70°C	-20° to +60°C

— 3. Installation and commissioning —

3.1 SLM1

Supplied parts list (switch kit):

1	1 x SLM1 limit switch housing and internals
2a	1 x M5 bolt (L10 mm)
2b	1 x M5 washer
3	1 x Rotary link, slotted
4	1 x SLM1 bracket
5	4 x Specific screws to screw in the plastic (5 mm)
6	1 x Take-off-arm
7	1 x Spindle connector
8	1 x Link pin
9	2 x M5 x 10 mm bolts

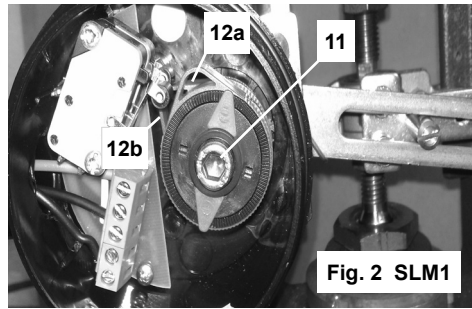

10	1 x M8 x 30 mm
11	1 x Cam bolt
12a	Top
12b	Bottom

3.1.1 Switchbox mounting

Refer to Figure 4 that illustrates a general assembly diagram using the SLM1:

- Attach the rotary link (3) onto the SLM1 limit switch housing (1) using the M5 screw (2a) and its washer (2b).
- Mount the SLM1 bracket (4) onto the SLM1 limit switch housing using the 4 screws (5). Apply caution when tightening the screws into the SLM1 housing as it is manufactured from plastic.
- Using the connection kit: Attach the take-off-arm (6) onto the actuator spindle connector (7) using the 2 x M6 screws (9). Fitting the link pin (8) to the take-off-arm (6).
- Fit all component parts of the SLM1 to the actuator yoke using the M8 bolt (10). For a stroke, less or equal to 20 mm, you will need to alter the link pin (8) position on the take-off-arm (6) to vary the rotational movement from the linear travel.

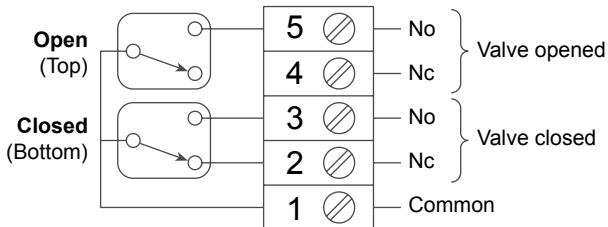

Fig. 3 SLM1 wiring diagram

3.1.2 Setting the switch

Adjusting the switch for a valve closed position

Referencing Figure 2 - Start with the valve and actuator assembly in the valve closed position. Untighten the screw (11) to free the two cams (12a and 12b), approximately 3 turns, and adjust the bottom cam to activate the bottom switch.

Referencing Figure 3 - Check the **continuity** between contact 1 and contact 3 (NO) and the **non continuity** between contact 1 and contact 2 (NC) with an ohmmeter.

Adjusting the switch for a valve open position

Referencing Figure 2 - Start with the valve and actuator assembly in the valve open position. Adjust the top cam to turn on the top switch. Tighten the screw (11) holding the cams in place. Referencing Figure 3 - Check with the ohmmeter the **continuity** between contact 1 and contact 5 (NO) and the **non continuity** between contact 1 and contact 4 (NC).

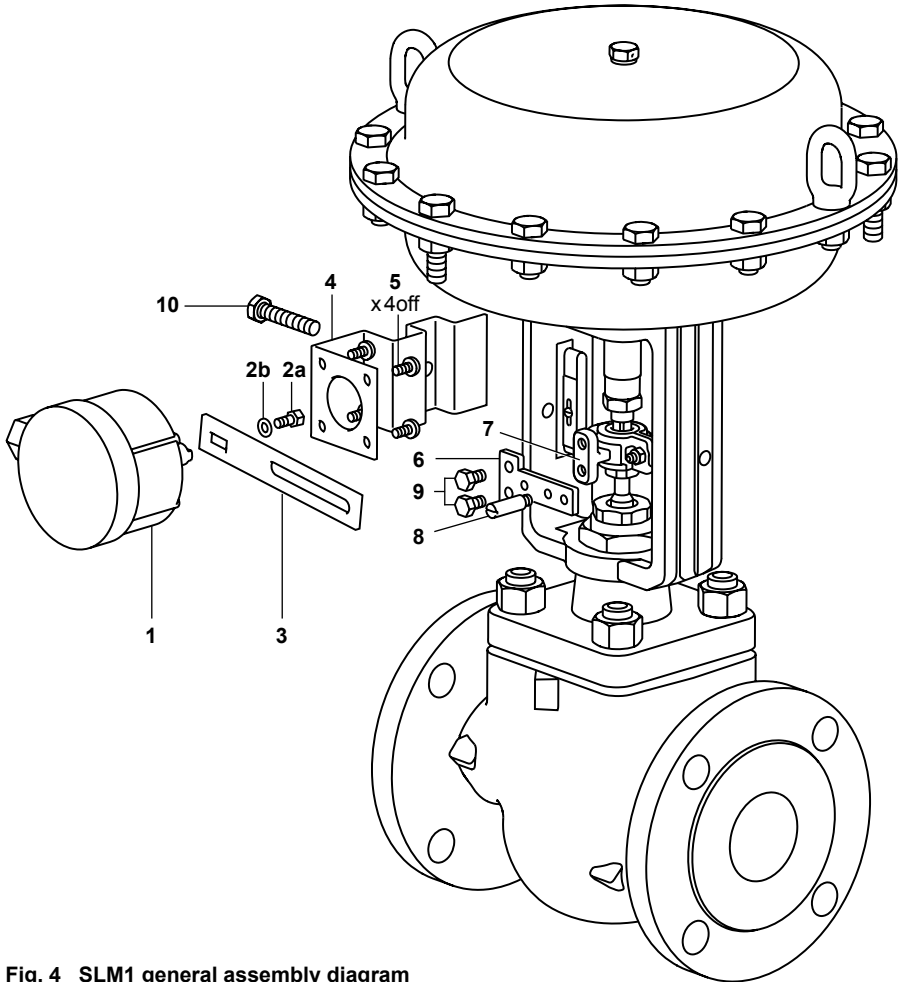

Fig. 4 SLM1 general assembly diagram

Please note:

If you decide to mount the SML1 onto a PN9000 actuator and a positioner was already mounted (such as an SP500) you must add the following part:

3579020 = 20 mm lift/travel, (for example PN91XX, PN922X or PN932X).

3579420 = 30 mm lift/travel, (for example PN923 or PN933X).

3.2 SLM2

Supplied parts list:

1	1 x Take-off-arm
2	1 x SLM2 bracket
3	2 x SLM2 units
4	4 x M5 x 10 mm bolt
5	4 x M5 nut
6	1 x M8 x 30 mm bolt

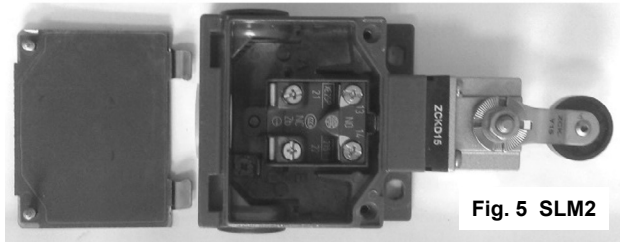

3.2.1 Switchbox mounting

Refer to Figure 7 that illustrates a general assembly diagram using the SLM2:

- Finger tighten the two sensors (3) onto the SLM2 bracket (2) using the four M5 screws (4).
Tip: This is easier when the bracket is not mounted on the actuator yoke.
- Fit the take-off-arm (1) onto the actuator coupling and mount the SLM2 assembly (sensors and bracket) onto the yoke of the actuator using the M8 screw (6).
- Now that the SLM2 assembly is attached to the actuator you can proceed to tighten the two sensors (3) onto the bracket (2).

Wiring connection:

Each sensor unit can be wired either normally open (high Green) or normally closed (low red). Select the required signaling and wire accordingly as per Figure 6.

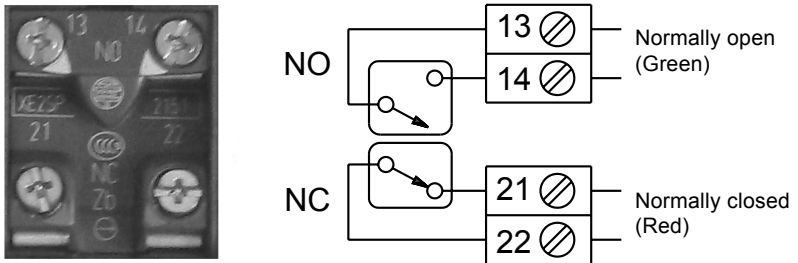

Fig. 6 SLM2 wiring diagram

3.2.2 Setting the switch

Adjusting the switch for a valve closed position

Start with the valve and actuator assembly in the valve closed position, and the lower switch box below the take-off-arm (1). Bring the sensor unit (3) up until you hear an audible 'click' - Then proceed to fit the sensor using the two locking nuts (5).

Adjusting the switch for a valve open position

Start with the valve and actuator assembly in the valve open position, and the higher switch box above the take-off-arm (1). Bring the sensor unit (3) down until you hear an audible 'click' - Then proceed to fit the sensor using the two locking nuts (5).

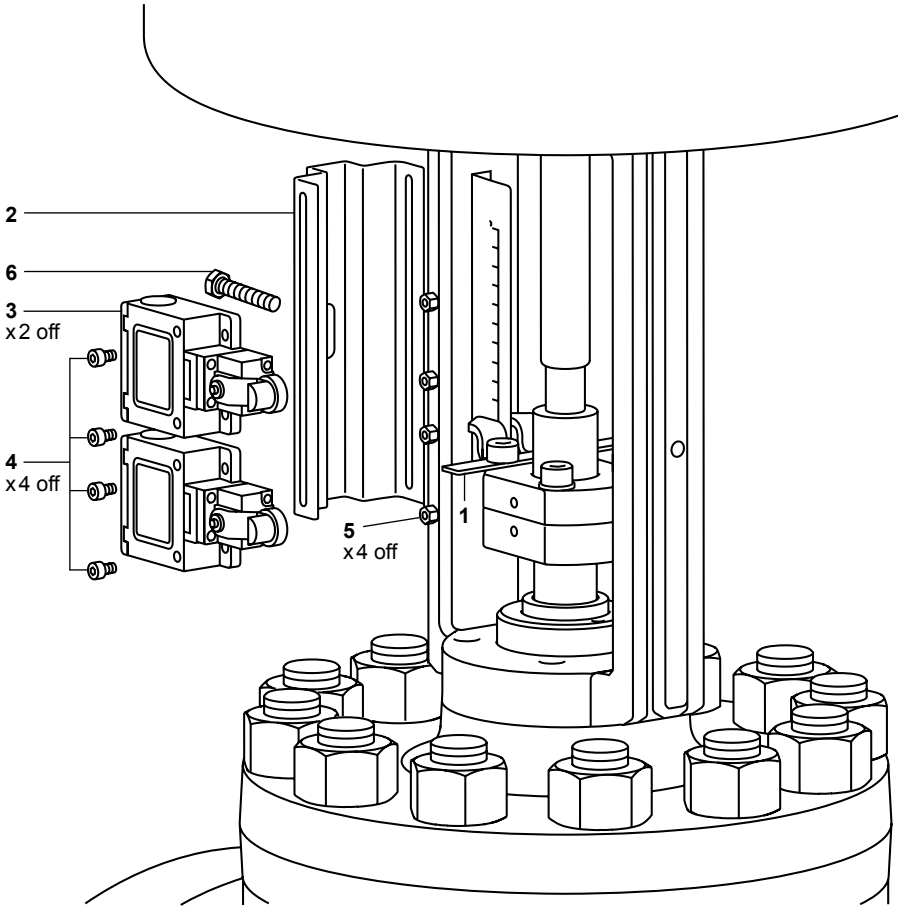
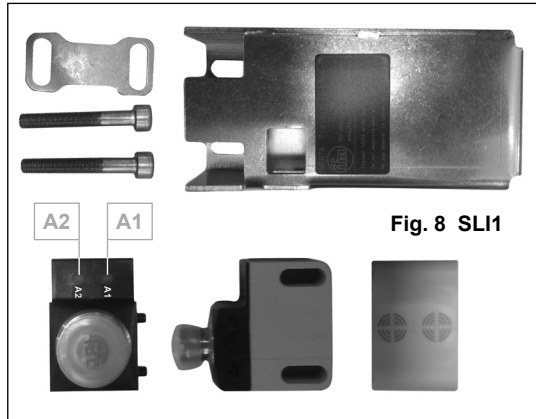

Fig. 7 SLM2 general assembly diagram

3.3 SLI1

Supplied parts list:

1	1 x Take-off-arm
2	1 x Protection sleeve
3	1 x Spacer
4	1 x SLI1 sensor unit
5	1 x SLI1 bracket
6	2 x M5 x 10 mm bolt
7	2 x M5 x 40 mm screws
8	2 x M5 nuts
9	1 x M8 x 10 mm bolt



3.3.1 Switchbox mounting

Refer to Figure 10 that illustrates a general assembly diagram using the SLI1:

- Connect the cable to the sensor (4).
- Mount the sensor (4) into the steel protection (2) and attach the fixing kit (3) using the 2 x M5 screws and nuts (other side of bracket 5) (7 + 8). **Caution:** You must leave a distance of 1 mm between the housing and the end of the sensor and another 1 mm between the end of the sensor and the SLI bracket (5).
- Apply pressure to the actuator to drive it to its middle stroke and untighten the locking nut on the actuator valve stem.
- Fit the take-off-arm (1 by slipping it onto the actuator stem and securing its position by using the 2 x M5 bolts (6) around the stem and thighten the actuator locking nut.

Wiring connection:

- **Valve is in the open position**, the pin 4 is active (10-30 V) and pin 2 is inactive (0 Vdc).
- **Valve is in the closed position**, the pin 4 is inactive (0-1 V) and pin 2 is active (10-30 V).

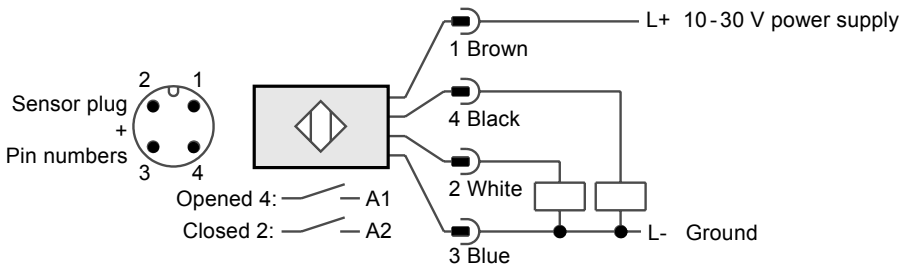

Fig. 9 SLI1 wiring diagram

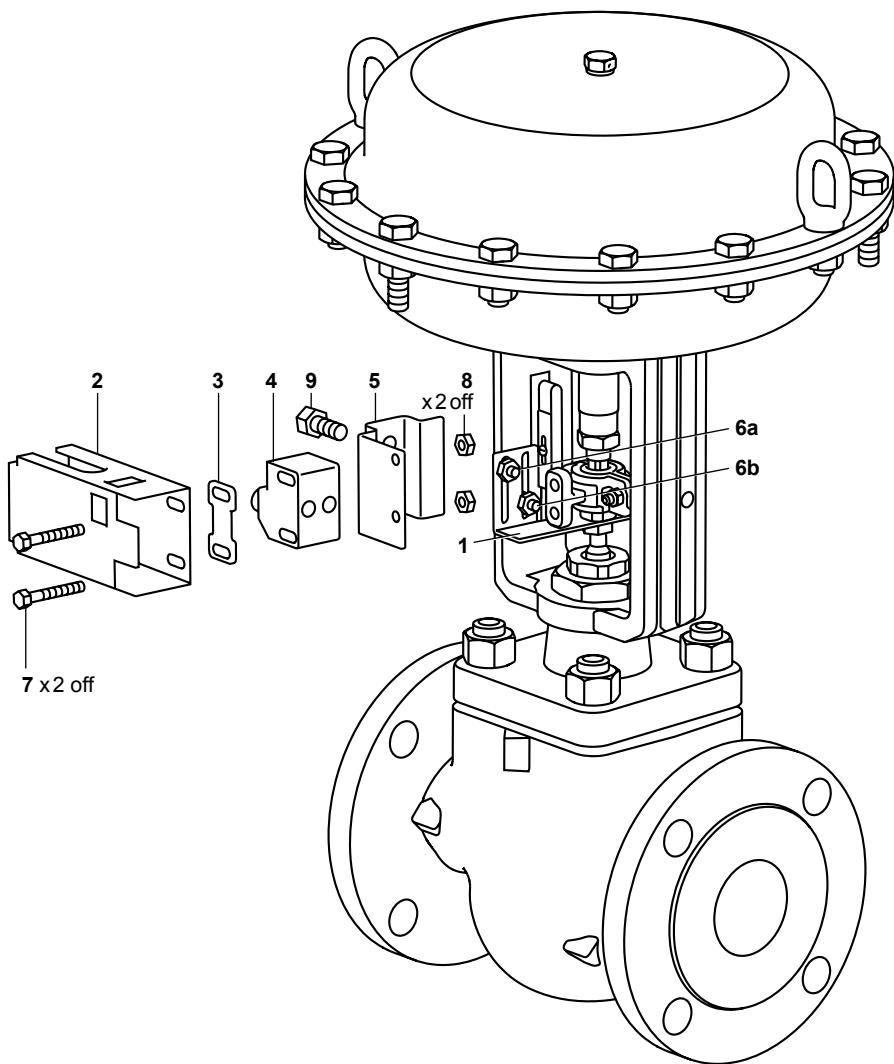

Fig. 10 SLI1 general assembly diagram

3.3.2 Setting the switch

Adjusting the switch for a valve closed position

Start with the valve and actuator assembly in the fully closed position and the bolt (6a) at the bottom of the slot. Slide the bolt (6a) up until the light (A2 - see Figures 8 and 9) on the rear of the sensor is illuminated - Then proceed to tighten the bolt 1 mm below.

Adjusting the switch for a valve open position

Start with the valve and actuator assembly in the fully open position and the bolt (6b) at the bottom of the slot. Slide the bolt (6b) up until the light (A1 - see Figures 8 and 9) on the rear of the sensor is illuminated - Then proceed to tighten the bolt 1 mm above.

3.4 SLI2

Supplied parts list:

1	1 x Take-off-arm
2	1 x SLI2 bracket
3	2 x SLI2 sensors
4	1 x M8 x 20 mm bolt
5	4 x M12 sensor nuts
6	2 x SLI2 cables



Fig. 11 SLI2

3.4.1 Switchbox mounting

Reference Figure 13 that illustrates a general assembly diagram using the SLI2:

- Apply pressure to the actuator to drive it to its middle stroke.
- Untighten the locking nut on the actuator valve stem and slip the take-off-arm (1) around the stem. The take-off-arm has an 8 mm groove for the DN15 - DN50 valve stem and a 12 mm groove for the DN65 - DN100 valve stem.
- Tighten the locking nut.
- Attach the SLI2 bracket (2) onto the actuator yoke with the M8 screw (4), and mount the sensor(s) using the locking nut(s) (5) - Please note that there must be a 1 mm distance between the sensor and the take-off-arm (1).

Wiring connection:

Choose between an active or inactive output if the valve is in the desired position.

If the valve is closed and we look at the bottom sensor:

- Output 2 (normally open: NO) is active = 10 - 30 Vdc
- Output 4 (normally closed: NC) is inactive = 0 Vdc

If the valve is not closed:

- Output 2 is inactive = 0 Vdc
- Output 4 is active = 10 - 30 Vdc

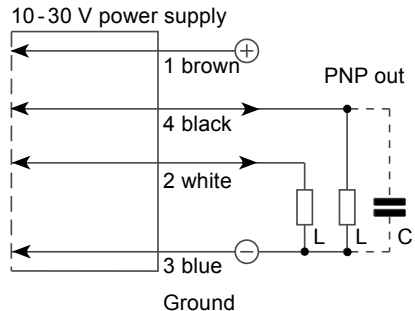
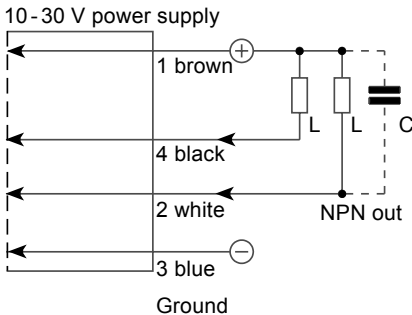

Fig. 12 SLI2 wiring diagram

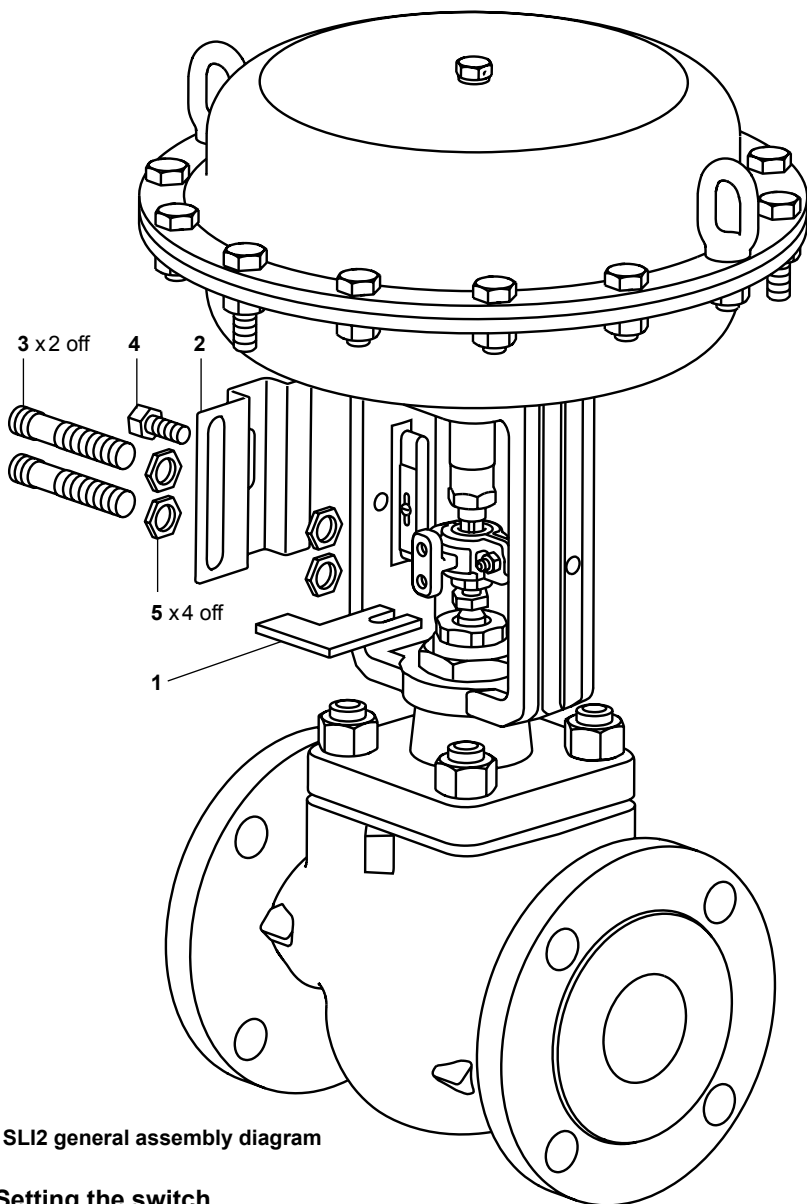

Fig. 13 SLI2 general assembly diagram

3.4.2 Setting the switch

Adjusting the switch for a valve closed position

Start with the sensor in the down position and allow it to move upwards until you see the sensor light illuminate - Then proceed to fit the sensor 1 mm above using the two locking nuts.

Adjusting the switch for a valve open position

Start with the sensor in the up position and allow it to move downwards until you see the sensor light illuminate - Then proceed to fit the sensor 1 mm below using the two locking nuts.

