

**SIB30, SIB30H and SIB45**  
**Sealed Inverted Bucket Steam Traps**  
**Installation and Maintenance Instructions**

---

---

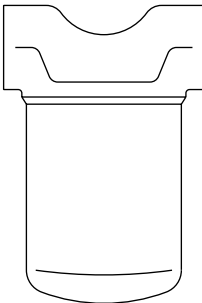

**SIB30**

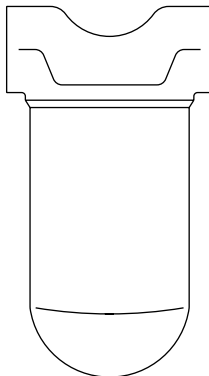

**SIB45**

- 1. *General safety information*
- 2. *General product information*
- 3. *Installation*
- 4. *Commissioning*
- 5. *Operation*
- 6. *Maintenance*
- 7. *Spare parts*

# — 1. *General safety information* —

Safe operation of these units can only be guaranteed if they are properly installed, commissioned and maintained by a qualified person (see Section 11 of the attached Supplementary Safety Information) in compliance with the operating instructions. General installation and safety instructions for pipeline and plant construction, as well as the proper use of tools and safety equipment must also be complied with.

## **Isolation**

Consider whether closing isolating valves will put any other part of the system or personnel at risk. Dangers might include; isolation of vents and protective devices or alarms. Ensure isolation valves are turned off in a gradual way to avoid system shocks.

## **Pressure**

Before attempting any maintenance consider what is or may have been in the pipeline. Ensure that any pressure is isolated and safely vented to atmospheric pressure before attempting to maintain the product, this is easily achieved by fitting Spirax Sarco depressurisation valves type DV (see separate literature for details). Do not assume that the system is depressurised even when a pressure gauge indicates zero.

## **Temperature**

Allow time for temperature to normalise after isolation to avoid the danger of burns and consider whether protective clothing (including safety glasses) is required.

## **Disposal**

These products are recyclable. No ecological hazard is anticipated with the disposal of these products providing due care is taken.

## — 2. General product information —

### 2.1 General description

The SIB30, SIB30H and SIB45 are all stainless steel sealed inverted bucket steam traps. They are supplied with a specified pressure change assembly depending on the required operating pressure differential. The traps are available with a range of seat sizes to suit pressure differentials between 0.5 to 30 bar (7.25 to 435 psi) for the SIB30/SIB30H and 0.5 to 45 bar (7.25 to 652.5 psi) for the SIB45. Traps for 45 bar are also provided with an inbuilt check valve as standard.

**Note:** For additional information see the following Technical Information Sheets:

**SIB30 and SIB30H** TI-P110-01

**SIB45** TI-P110-02

### 2.2 Sizes and pipe connections

#### SIB30, SIB30H

½" and ¾" screwed BSP or NPT and socket weld ends (BS 3799)

DN15 and DN20 standard flange ANSI 150 and ANSI 300, BS 4504 PN40.

Flanges are also available for JIS Tables 20, 16 and 10.

#### SIB45/5

½" and ¾" butt weld ends to ANSI B 16.5 (to suit ANSI B 36.10 Schedule 80 pipe).

½" and ¾" socket weld ends BS 3799 Class 3000.

DN20 and DN25 standard flanges DIN2547 PN100 and ANSI 600.

#### SIB45/6, SIB45/8, SIB45/10

¾" and 1" screwed BSP or NPT.

DN20 and DN25 standard flanges ANSI 150 and ANSI 300.

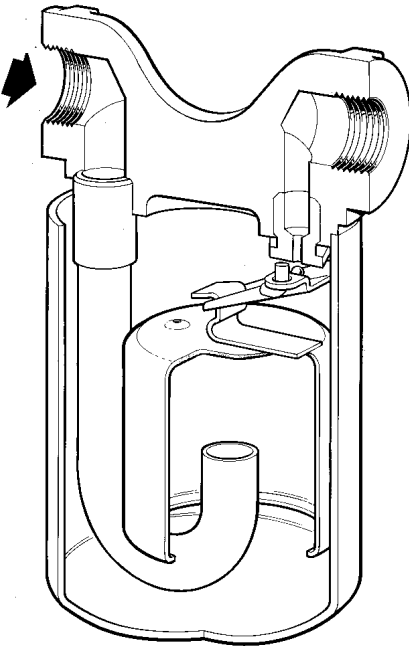

Fig.1 SIB30

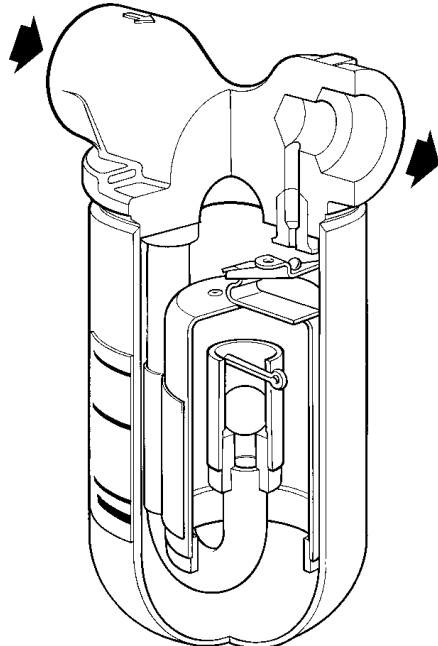

Fig.2 SIB45/5

## 2.3 Limiting conditions (ISO 6552)

### SIB30 and SIB30H

Body design conditions	PN50	(ANSI 300)
PMA - Maximum allowable pressure	50 bar g	(725 psi g)
TMA - Maximum allowable temperature	400°C	(752°F)
PMO - Maximum operating pressure	30 bar g	(435 psi g)
TMO - Maximum operating temperature	400°C	(752°F)
Designed for a maximum cold hydraulic test pressure of:	75 bar g	(1 087.5 psi g)

### SIB45

Body design conditions	PN100	(ANSI 600)
PMA - Maximum allowable pressure	100 bar g	(1 450 psi g)
TMA - Maximum allowable temperature	450°C	(842°F)
PMO - Maximum operating pressure	60 bar g	(870 psi g)
TMO - Maximum operating temperature	450°C	(842°F)
Designed for a maximum cold hydraulic test pressure of:	150 bar g	(2 175 psi g)

## 2.4 Operating ranges

### SIB30 and SIB30H

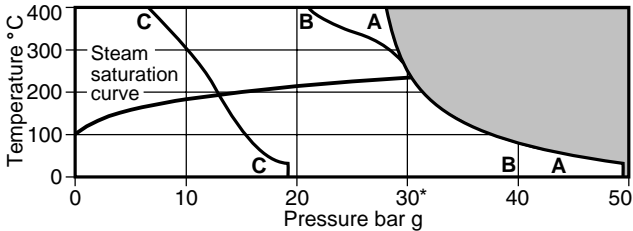

 The product must not be used in this region.

\*PMO Maximum operating pressure recommended.

**A - A** Flanged ANSI 300, screwed and socket weld.

**B - B** Flanged BS 4504 PN40.

**C - C** Flanged ANSI 150.

### SIB45

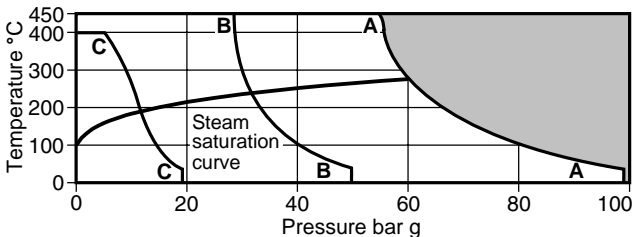

 The product must not be used in this region.

\*PMO Maximum operating pressure recommended.

**A - A** Screwed, butt weld, socket weld, flanged DIN 2547 PN100 and ANSI 600.

**B - B** Flanged ANSI 300.

**C - C** Flanged ANSI 150.

---

**ΔPMX - Maximum differential pressure**

<b>ΔPMX bar</b>	<b>SIB30</b>	<b>SIB30H</b>	<b>SIB45</b>
<b>45.0</b>	-	-	SIB45/5
<b>30.0</b>	SIB30/4	SIB30H/5	-
<b>20.0</b>	SIB30/5	SIB30H/6	SIB45/6
<b>12.0</b>	SIB30/6	SIB30H/7	-
<b>8.5</b>	SIB30/7	SIB30H/8	SIB45/8
<b>5.0</b>	-	SIB30H/10	-
<b>4.0</b>	SIB30/8	-	-
<b>4.5</b>			SIB45/10
<b>2.5</b>	SIB30/10	-	-
<b>2.0</b>	-	SIB30H/12	-
<b>1.5</b>	SIB30/12	-	-

**Note:** The pressure limit of the flange type should be greater than the pressure limit of the internal mechanism selected.

---

## 3. Installation

---

**Note:** Before actioning any installation observe the 'Safety information' in Section 1.

Referring to the Installation and Maintenance Instructions, name-plate and Technical Information Sheet, check that the product is suitable for the intended installation:

- 3.1** Check materials, pressure and temperature and their maximum values. If the maximum operating limit of the product is lower than that of the system in which it is being fitted, ensure that a safety device is included in the system to prevent overpressurisation.
- 3.2** Determine the correct installation situation and the direction of fluid flow.
- 3.3** Remove protective covers from all connections.
- 3.4** The trap must be installed with the body upright so that the bucket is rising and falling vertically. When superheat conditions exist the trap body may need to be primed with water prior to steam being turned on to avoid steam blowing through the trap.
- 3.5** Inverted bucket steam traps do not permit rapid release of air. On process applications, in particular, this can lead to slow warm-up times and waterlogging of the steam space. A separate external air vent is therefore required in parallel to vent air efficiently. Any bypass should be positioned above the trap. If it is below, and is leaking or left open, the waterseal could be blown away leading to steam wastage. Where inverted bucket traps are fitted in exposed conditions the possibility of freezing damage can be reduced by thermal insulation.
- 3.6** Traps must be installed in a horizontal pipeline. The inlet of the trap should be below the drain point of the plant being drained, so that a waterseal can be maintained around the open end of the bucket. A small drop leg should precede the trap - typically 150 mm (6").
- 3.7** Where the trap discharges into a closed condensate return system or where there is a lift at the trap, a check valve should be fitted downstream of the trap.
- 3.8** If the trap has to be installed at a higher point than the drainage point, then a small bore riser into a 'U' seal should be used. A check valve should be fitted before the trap to prevent the loss of the internal waterseal.
- 3.9** If the trap is installed on a superheated steam system application, then a non return valve should be fitted on the trap inlet, to prevent the trap from losing its waterseal. Priming of the trap with water may be required before commissioning.
- 3.10** When welding the trap into the pipeline, this should be carried out by electric arc process. If installed in exposed positions, considerations should be given to insulating the trap.

**Note 1:** If the trap is to discharge to atmosphere ensure it is to a safe place, the discharging fluid may be at a temperature of 100°C (212°F).

**Note 2:** On all blast discharge steam traps check valves and sight glasses must be installed at least 1 metre (3 ft) downstream of the trap.

---

## 4. Commissioning

---

After installation or maintenance ensure that the system is fully functional. Carry out tests on any alarms or protective devices.

---

## 5. Operation

---

Under most conditions the trap will discharge condensate with a blast type action. Under low load and/or low pressure applications the discharge may tend to 'dribble'. Condensate is discharged at steam temperature so due care must be given to the site of the discharge.

---

## 6. Maintenance

---

The SIB30 and SIB45 are factory set sealed steam traps. They are non-adjustable and require no maintenance.

---

## 7. Spare parts

---

The SIB30/SIB30H and SIB45 are sealed, non-maintainable, steam traps. Therefore no spares are available.

### How to order a new product

**Example:** 1 - Spirax Sarco SIB30/6 ½" screwed BSP sealed inverted bucket steam trap.

**Note:** The cover (and flanges when specified) are welded to the body using the TIG process. Welds are approved in accordance with ASME Section IX and BS EN 288.

