

Series A
Electric Linear Actuators
Installation and Maintenance Instructions



1. Safety information
2. General product information
3. Installation
4. Commissioning
5. Maintenance
6. Wiring diagrams

1. Safety information

See separate Installation and Maintenance Instruction for the control valve.

Your attention is drawn to Safety Information Leaflet IM-GCM-10, as well as any National and Regional regulations.

All personnel using this product must read this manual carefully prior to operation.

If these Actuators are handled improperly or not used as specified, the resultant may:

- Cause danger to the life and limb of the user or a third party.
- Damage the actuator and other assets belonging to the owner.
- Reduce the performance of the actuator.

Wiring notes

Every effort has been made during the design of the actuator to ensure the safety of the user, but the following precautions must be followed:

- i) All maintenance personnel must be suitably qualified in working with equipment containing hazardous live voltages.
- ii) Ensure correct installation. Safety may be compromised if the installation of the product is not carried out as specified in this manual.
- iii) Isolate the actuator from the mains supply before opening the unit.
- iv) The actuator is designed as an installation category II product, and is reliant on the building installation for over-current protection and primary isolation.
- v) All external circuits must meet the requirements of double insulation as stated in IEC 60364 or equivalent.
- vi) Wiring should be carried out in accordance with IEC 60364 or equivalent.
- vii) Suitably rated fuses should be fitted in all phases of the actuator's supply. Fuses should not be fitted in the protective earth conductor. The disconnection or removal of other equipment must not compromise the integrity of the installed protective earth system.
- viii) A disconnecting device (switch or circuit breaker) must be included in the building installation. This must be in close proximity to the equipment and within easy reach of the operator. The following must be observed:
 - There must be a 3 mm contact separation in all poles.
 - It must be marked as the disconnecting device for the actuator.
 - It must not interrupt the protective earth conductor.
 - It must not be incorporated into a mains supply cord.
 - The requirements for the disconnecting device are specified in IEC 60947-1 and IEC 60947-3 or equivalent.
- ix) The motor contactors must be switched off directly by the limit or torque switch to ensure a maximum time delay of 20 ms.
- x) The actuator must not be located in such a way that the disconnecting device is made difficult to operate.

Safety requirements and electromagnetic compatibility

This product is CE marked. It complies with the requirements of 73/23/EEC as amended by 93/68/EEC on the harmonisation of the law of Member States relating to electrical equipment designed for use within certain voltage limits, by meeting the standard EN 60204-1, EN 60034-1 and VDE 0100 Part 410.

WARNING:

This product complies with the requirement of Electromagnetic Compatibility Directive 89/336/EEC as amended by 92/31/EEC and 93/68/EEC on the approximation of the laws of the Member States relating to electromagnetic compatibility, by meeting the standards of:

- BS EN 50081-2:1993 (Emissions) and
- BS EN 50082-2:1995 (Industrial Immunity).

This product may be exposed to interference above the limits of BS EN 50082-2 if:

- The product or its wiring is located near a radio transmitter.
- Excessive electrical noise occurs on the main supply.

Cellular telephones and mobile radios may cause interference if used within approximately three metres of the product or its wiring. The actual separation necessary will vary according to the power of the transmitter.

Power line protectors (ac) should be installed if mains supply noise is likely. Protectors can combine filtering, suppression, surge and spike arrestors.

WARNING:

If this product is not used in the manner specified by this IMI, then the protection provided may be impaired.



Fig. 1

2. General product information

2.1 Description

The series A electric actuators are suitable for control of two and three port globe valves. There are four types offering on/off or regulating control using either external motor contactors or integral motor controls (switched logic).

Available sizes:

Two sizes having thrusts of 37.5 kN or 64 kN.

Available linkage kits:

Four linkage kits are available which enable mounting to KE, KEA and QL valves, DN125, DN150 and DN200. Linkage kits include output drive (LE or A) column assembly and valve spindle attachments.

Available types:

Note: Control type VMD (external contactor) will require additional switching equipment not supplied with these actuators.

On/off actuators

Size	Voltage	Model No.	Control	Actuator motor rating to VDE 0530/IEC 6034	Linkage kit
10.1	240 V	A10.1 1-22	VMD (external contactor)	S2 = 10 min	A10
	1 phase	AM10.1 1-22	VMD (switched logic)	S2 = 10 min	
10.1	400 V	A10.1 3-22	VMD (external contactor)	S2 = 15 min	
	3 phase	AM10.1 3-22	VMD (switched logic)	S2 = 15 min	
14.1	400 V	A14.1 3-22	VMD (external contactor)	S2 = 15 min	A14
	3 phase	AM14.1 3-22	VMD (switched logic)	S2 = 15 min	

Regulating actuators

10.1	400 V	AR10.1 3-22	VMD (external contactor)	S4 = 25%	LE10
	3 phase	ARM10.1 3-22	0/4-20 mA and 0-5 V	S4 = 25%	
14.1	400 V	AR14.1 3-22	VMD (external contactor)	S4 = 25%	LE14
	3 phase	ARM14.1 3-22	0/4-20 mA and 0-5 V	S4 = 25%	

2.2 Technical data for A and AM models

Model	On/off control					
	A			AM		
Size	10.1	10.1	14.1	10.1	10.1	14.1
Supply voltage Vac ($\pm 5\%$)	230	400	400	230	400	400
Supply frequency	50 Hz					
Actuator thrust max. kN	37.5	37.5	64	37.5	37.5	64
Regulating thrust kN	18.8	18.8	30.8	18.8	18.8	30.8
Supply current A	8	1.8	3.5	8	1.8	3.5
Enclosure rating to EN 60529	IP65	IP67		IP65	IP67	
Actuator speed mm/sec	2.3	2.3	2.3	2.3	2.3	2.3
Motor terminations	6 mm ²					
Control terminations	2.5 mm ²					
Conduit entries	Plug and socket unit with 2 x Pg 21, 1 x Pg 13,5					
Ambient limits	-25°C to +80°C			-25° to +70°C		
Actuator motor rating to VDE 0530/IEC 60034-1 (mins)	S2 = 10	S2 = 15		S2 = 10	S2 = 15	
Maximum starts /hour	60					
Design life starts (x 10 ⁶)	0.5					

2.3 Operation

These actuators consist of four main modules the electric drive motor, gear casing, control unit and output drive. The worm gearing reduces the high torque electric motor drive to the required speed where it couples to the output drive device. The standard control unit consists of limit and torque switches that can be used to control actuator seating and overload. When supplied these actuators are configured to torque seat in the close direction and limit seat in the open direction. If however the actuator is supplied coupled to a Q series valve both open and close directions will torque seat. Additional programmable motor control features are available with the AM and ARM models. The service conditions of these electric actuators are: S2-short time service and S4-intermittent service according to IEC 60034-1,8.

2.4 Manual operation

Attention: Manual operation should only be engaged with motor still.

- Lift the change over lever in the centre of handwheel approximately 85° while slightly turning the handwheel.
- Release the changeover lever (snaps back to initial position by spring action); manual drive will remain engaged. In case lever does not snap back by itself, manually assist.

Manual operation disengages automatically when motor is started.

2.5 Materials

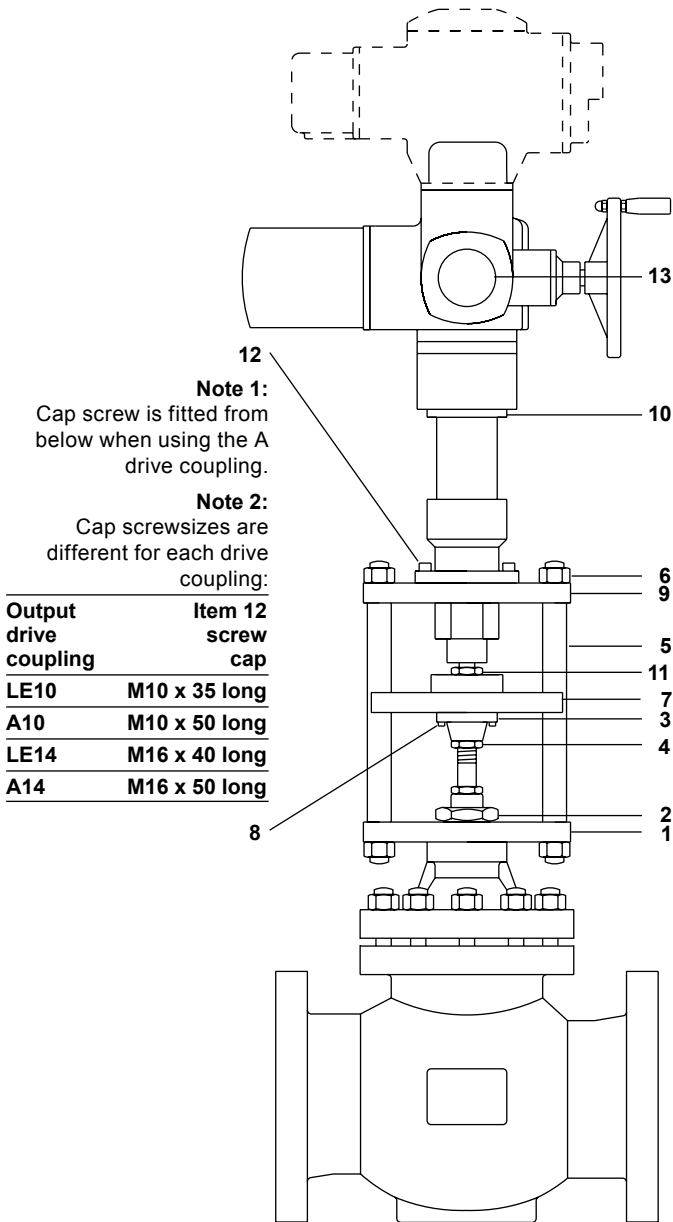

Fig. 2

2.6 Technical data for AR and ARM models

Model	Regulating control			
	AR		ARM	
Size	10.1	14.1	10.1	14.1
Supply voltage Vac ($\pm 5\%$)	400	400	400	400
Supply frequency	50 Hz			
Actuator thrust max. kN	37.5	64	37.5	64
Regulating thrust kN	18.8	30.8	18.8	30.8
Supply current A	1.8	3.5	8	3.5
Enclosure rating to EN 60529	IP67		IP67	
Actuator speed mm/sec	2.2	2.5	2.2	2.5
Motor terminations	6 mm ²			
Control terminations	2.5 mm ²			
Conduit entries	Plug and socket unit with 2 x Pg 21, 1 x Pg 13,5			
Ambient limits	-25°C to +80°C		-25° to +70°C	
Actuator motor rating to VDE 0530/IEC 60034-1 (mins)	S4=25%		S4=25%	
Maximum starts /hour	1200	900	1200	900
Design life starts (x 10 ⁶)	5	3.5	5	3.5

Fig. 3 Series A actuator fitted to LE drive coupling mounted to a valve



3. Installation

See separate Installation and Maintenance Instructions for the control valve.

Note: Before actioning any installation observe the 'Safety information' in Section 1.

3.1 Location

The actuator should be mounted above the valve with sufficient space to allow access to the handwheel, local control unit, and electrical connection plug. When selecting a location, make sure that the actuator is not exposed to ambient conditions exceeding the product range (see Table 1).

If necessary, provide insulation to prevent overheating. The actuator is IP rated when the covers are fitted correctly and the cable gland entries are tightened against the cables.

Table 1 Ambient temperature

A	-25°C to +80°C
AR and ARM	-25°C to +60°C
AM	-25°C to +70°C
All models	5 to 95% RH

3.2 Fitting the actuator to the valve



During mounting of the actuator to a valve, never drive the actuator electrically instead use the handwheel.

The actuator assembly is heavy and the correct lifting gear should be used to support the actuator weight.

When lifting do not attach lifting ropes or hooks to the handwheel.

A ready assembled valve/actuator should never be lifted using the actuator.

Normally the series A actuator will be supplied fitted to the valve. However should it be necessary to fit or replace an actuator, the following procedures should be adopted:

3.2.1 Fitting the valve adaptor flange

The mounting flange (1) must be fitted to the valve:

- Remove the actuator retaining nut (2) from the valve and place the mounting flange (1) over the valve bonnet.
- Refit the actuator retaining nut (2) and tighten to torque of 250 N m.

3.2.2 Fitting the lower valve linkage:

- Screw the valve linkage (3) onto the valve stem at least one thread diameter and loosely tighten the stem lock-nut (4).
- Fit 4 off pillars (5) and retain with nuts (6, see Fig. 4), tighten to 300 N m



Before the pillar nuts are tightened, make sure that the pillar ends are completely inserted into the bores of the valve mounting flange.

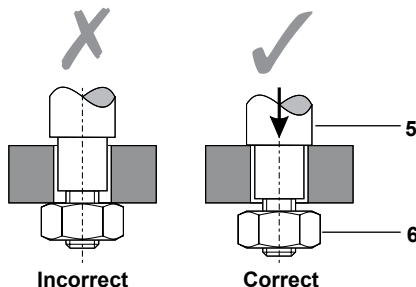

Fig. 4

3.2.3 Fitting the actuator to the valve

Follow this procedure for all models:

- Ensure the actuator output drive (10) is fitted to the actuator. Refer to the manufacturer's literature.
- Fit the actuator mounting flange (9) to the actuator output drive and retain with cap screws (12).

Output drive (10)	A10, LE10	A14, LE14
Cap screw (12)	M10	M16
Torque, setting	70 N m	200 N m

- Screw the anti-rotation plate (7) onto the actuator stem until the stem is engaged at least one thread diameter. Tighten lock-nut (11) M20 to 400 N m, M36 to 1000 N m.
- Ensure the actuator stem is fully retracted into the actuator. Use the handwheel to retract the actuator stem.
- Align the anti-rotation plate over the pillars and lower the actuator onto the pillars, ensuring the pillars are fully engaged and clearance exists between the anti-rotation plate (7) and the valve linkage (3).
- Fit and tighten pillar nuts (see Fig. 4) to a torque of 300 N m.
- Ensure the valve stem is pushed down until the valve plug is fully seated.
- Using the handwheel lower the actuator stem until the anti-rotation plate and valve linkage are in contact. If this is not achieved:
 - Unwind the handwheel one turn.
 - Adjust the anti-rotation plate and/or the valve linkage until contact is made.

Warning: Ensure the valve stem thread engagement is not less than one thread diameter.

- Align the anti-rotation plate and valve linkage so the fixing holes will accept the four (M10 x 35 long) coupling cap head screws (8) and tighten to a torque of 70 N m.
- Using the handwheel ensure that the actuator will fully travel the valve.
- Tighten valve lock-nut (4) to 200 N m.

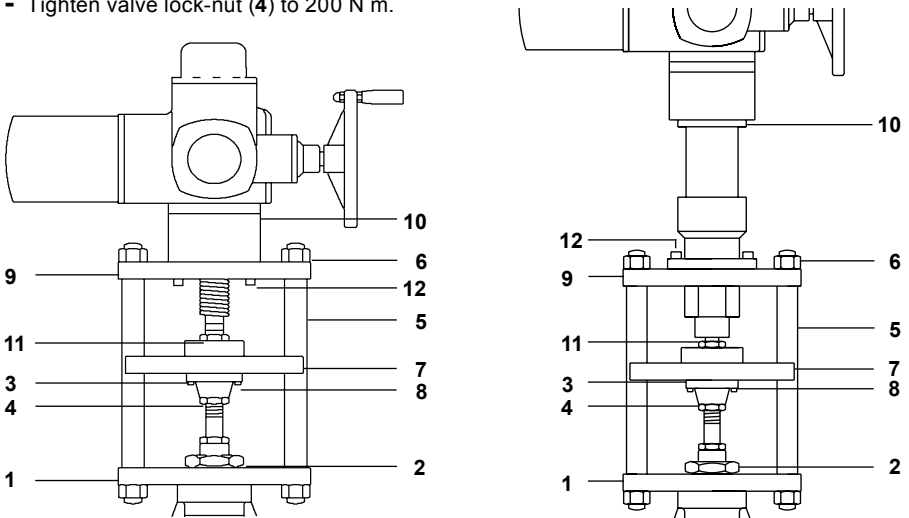

Fig. 5 A10/A14 linkage kit

LE10/LE14 linkage kit

3.3 Removing and refitting the electrical connection cover



Ensure power is disconnected before removing the cover.

To remove the connection plug (14) loosen the hex head slotted retaining screws (15) and lift clear. Before refitting the cover clean sealing faces and check 'O' ring for damage. Apply a thin film of non acidic grease, replace plug and tighten screws diagonally.

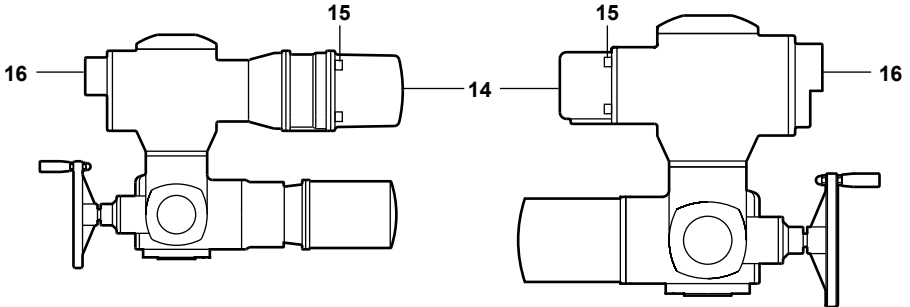

Fig. 6 AM10.1 actuator

AM14.1/ARM14.1 actuator

3.3.1 Wiring details



Connection to the mains supply is important.

Important:

- Read 'Safety information' (Wiring notes, Section 1), before attempting to wire the supply to the actuator.
- Complete protection of the motors will only be guaranteed if the thermo-switches in the windings are wired correctly.
- Slow blow fuses should be fitted in all phases, but not in the protective earth conductor.
- The protective earth terminal must be connected to the installation protective earth system. Disconnection or removal of other equipment must not compromise the integrity of the installation protective earth system.
- For power supply connections (10 mm² screw terminals), use 6 mm² wire, double insulated as stated in IEC 60364 (or equivalent), if wires are exposed to touch.
- For control signals connections (4 mm² screw terminals), use 2.5 mm² wire.
- For AR and ARM models ensure that the 4-20 mA output terminals 23 and 24 on plug/socket connector (14) are connected to a load. Alternatively these terminals must be connected together to ensure the input circuit is a 'Loop'. For further information on wiring refer to the manufacturers operating instructions.

3.3.2 Terminal connections

To access the screw terminals unscrew the four cheese head screws (15) holding the multi-pin socket into the plug (Fig. 6). For multi-pin terminal connections see appropriate terminal diagram. supplied with the actuator.

4. Commissioning

Complete the appropriate Sections, relative to the actuator being commissioned.

4.1 Preliminary tests:

- Remove the switch compartment cover (13, see Fig. 3) and position indicator disc. An open ended spanner (approximately 10 mm) may be used as a lever, to remove the position indicator disc

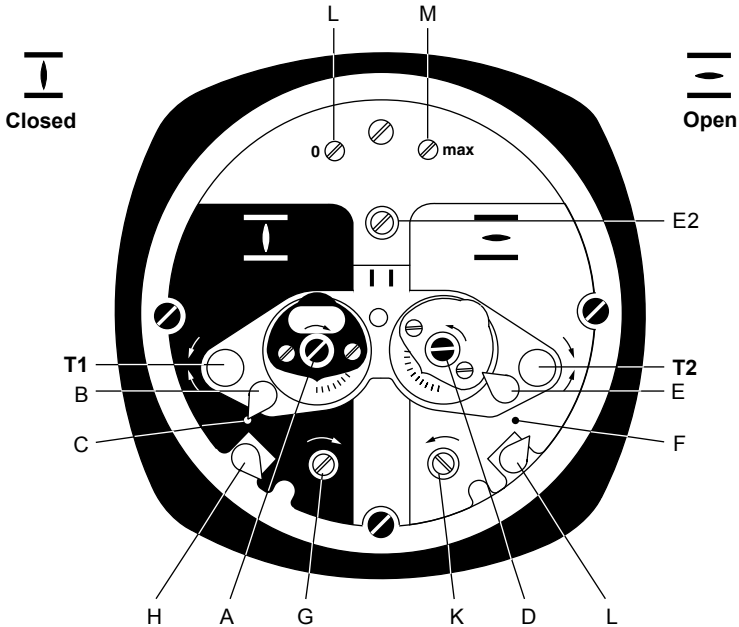

Fig. 7 Control unit diagram

- Using the handwheel move the valve to the mid-position.
- Briefly switch on the actuator in the **open** direction. Note the following:
 - i - **A and AR**: These models use external motor contactors and as such the operational switches must be accessible during the test run.
 - ii - **AM and ARM**: To control the operation the local control panel should be used (Fig. 3). Ensure the selector switch is turned to the 'local' position. Push the **Open** button to **open** and the **Close** button to **close**.
- Ensure the valve moves in the **open** direction, if not check the wiring.
- Whilst the valve moves in the **open** direction turn the right hand red test button (**T2**) (**open**) clockwise:
 - i - If the actuator stops, the control circuit is correctly wired.
 - ii - If the actuator does not stop also turn the left hand red test button (**T1**) (**close**) anticlockwise. This will produce an emergency stop of the actuator. The control circuit must then be checked and this test repeated.

Note: The two red test buttons (**T1**) and (**T2**) operate the torque and limit micro switches for test purposes.

4.2 Checking torque switch operation

For 2-port KE valves the limit switches should be used to stop the actuator in the **open** direction and to flag the seat zone in the **closed** position. For 3-port QL valves the limit switches are used to flag the seat zone in the **open** and **closed** position. Refer to the manufacturer's literature for the procedure to change the set up from the 2-port settings supplied to the 3-port settings. If supplied coupled to a valve the switches will be preset, and will only require checking should the valve and actuator be separated.

Note: For torque seating in the closed direction the limit switches flag the seat zone and must operate shortly before reaching the seat.

Attention: Actuators coupled to valves will have the torque switches set. Adjustment below this setting may result in insufficient closing forces being applied to the valve. See TI-P358-10 for further details.

Torque setting for A14.1, AR14.1, AM14.1, ARM14.1 64 kN thrust actuator:

	Stainless steel valves	Other material valves
	KE/QL 61-63	KE/QL
Open torque	18 da N m	25 da N m
Closed torque	18 da N m	25 da N m

Torque setting for A10.1, AM10.1 37.5 kN thrust actuator:

Set the torque to maximum 12 da N m.

4.2.1 Setting the closed torque switch (Black area, Fig. 8):

- Unlock screws **O** on torque dial.
- Rotate dial **P** to the required torque setting. The dial is marked in da N m, 1 da N m = 7.4 lbf ft.
- Tighten lock screws **O**.

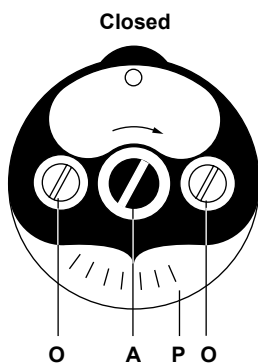

Fig. 8

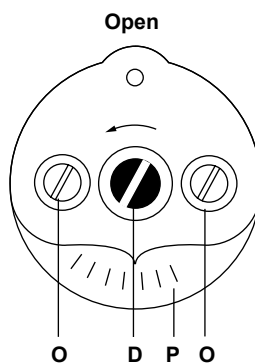

Fig. 9

4.2.2 Setting the open torque switch (White area, Fig. 9)

For torque seating in the closed direction the limit switch must operate shortly before reaching the seat:

- Unlock screw **O** on torque dial.
- Rotate dial **P** to the required torque setting. The dial is marked in da N m, 1 da N m = 7.4 lbf ft.
- Tighten lock screws **O**.

Attention: Following any adjustment ensure the actuator can apply sufficient thrust to overcome the applied pressures.

4.3 Checking the limit switches operation

For 2-port KE valves the limit switches should be used to stop the actuator in the open direction and to flag the seat zone in the **closed** position. For 3-port QL valves the limit switches are used to flag the seat zone in the **open** and **closed** position. If supplied coupled to a valve the switches will be preset, and will only require checking should the valve and actuator be separated.

Note: For torque seating in the **closed** direction the limit switches flag the seat zone and must operate shortly before reaching the seat.

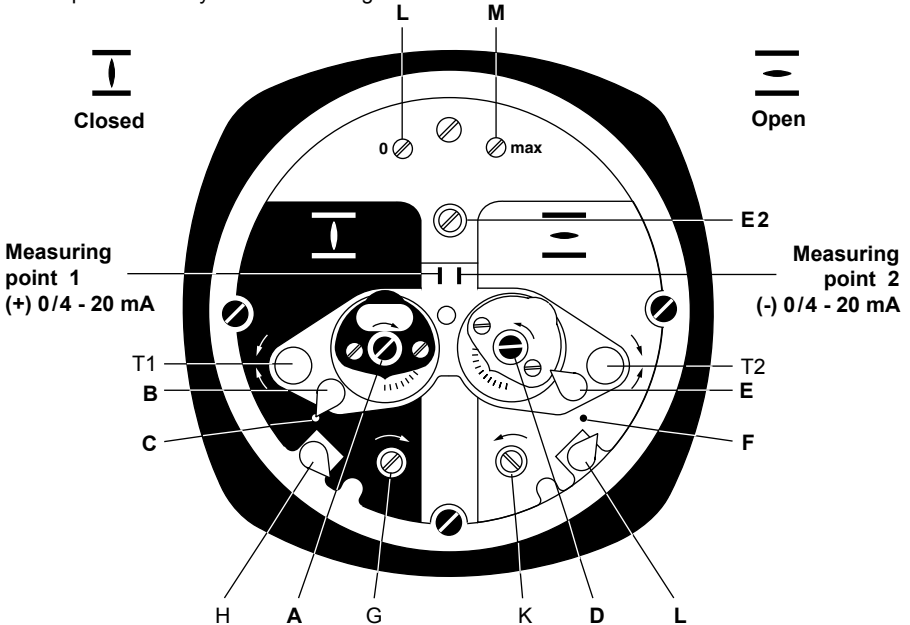

Fig. 10 Control unit diagram

4.3.1 For 2-port valves

Closed position limit switch (Black area, Fig. 11):

- Drive the actuator electrically until the torque switch, switches off the motor. At this point the stop light should be showing a fault.
- Turn the handwheel anticlockwise two turns.
- Press down and turn spindle **A** in the clockwise direction. Ratchet is felt and heard, pointer **B** will turn for every 90° of rotation. When the pointer approaches point **C** the spindle should not be turned any further. If the spindle has been turned beyond this point, continue turning and approach the setting point again.

Attention: Ensure spindle **A** springs out to its original position.

Open position limit switch (White area, Fig. 12):

- Turn the handwheel anticlockwise until the valve has fully travelled 50 mm.
- Using a 3 mm flat screwdriver push in and turn spindle **D** anticlockwise. Ratchet is felt and heard, pointer **E** will turn for every 90° of rotation. When the pointer approaches point **F** the spindle should not be turned any further. If the spindle has been turned beyond this point, continue turning and approach the setting point again.

Attention: Ensure spindle **D** springs out to its original position.

4.3.2 For 3-port valves

Closed Position limit switch (Black area, Fig. 11):

- Drive the actuator electrically until the torque switch, switches off the motor. At this point the stop light should be showing a fault.
- Turn the handwheel anticlockwise one turn.
- Press down and turn spindle **A** in the clockwise direction. Ratchet is felt and heard, pointer **B** will turn for every 90° of rotation. When the pointer approaches point **C** the spindle should not be turned any further. If the spindle has been turned beyond this point, continue turning and approach the setting point again.

Attention: Ensure spindle A springs out to its original position.

Open position limit switch (White area, Fig. 12):

- Drive the actuator electrically until the torque switch, switches off the motor. At this point the stop light should be showing a fault.
- Turn the handwheel clockwise one turn.
- Using a 3 mm flat screwdriver press down and turn spindle **D** anticlockwise. Ratchet is felt and heard, pointer **E** will turn for every 90° of rotation. When the pointer approaches point **F** the spindle should not be turned any further. If the spindle has been turned beyond this point, continue turning and approach the setting point again.

Attention: Ensure spindle D springs out to its original position.

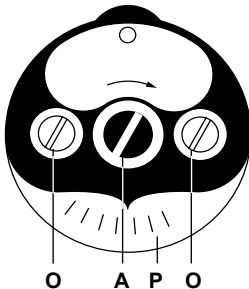

Fig. 11

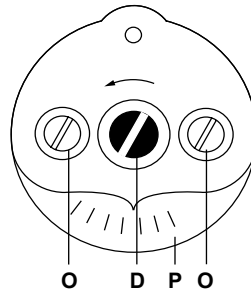

Fig. 12

4.4 Adjusting the position feedback transmitter

(AR and ARM models only, see Fig. 10):



Ensure that the 4-20 mA feedback terminals 23 and 24 on the plug/socket connector (14) are connected to a load. Alternatively these terminals must be connected together to make the mA loop.

- Drive the actuator to the fully **closed** position.
- Connect ammeter for 20 mA to measuring point (1) and (2) (Fig. 10). Refer to manufacturers instructions, for further connection details
- Using a 3 mm flat screwdriver turn screw **E2** clockwise until the mechanical stop is felt. Turn anticlockwise $\frac{1}{8}$ th of a turn.
- Trim potentiometer **L** clockwise until the output current starts to increase. Trim backwards until a reading of 0.1 mA is shown.
- Drive the actuator to the fully open position.
- Trim potentiometer **M** (max) until a signal of 20 mA is achieved.
- Run actuator again to check the closed position reading, and adjust if necessary.

4.5 Positioner card adjustment (ARM models only)



Before setting the positioner card ensure that the limit and torque switching of the actuator as well as the position feedback transmitter have been set.

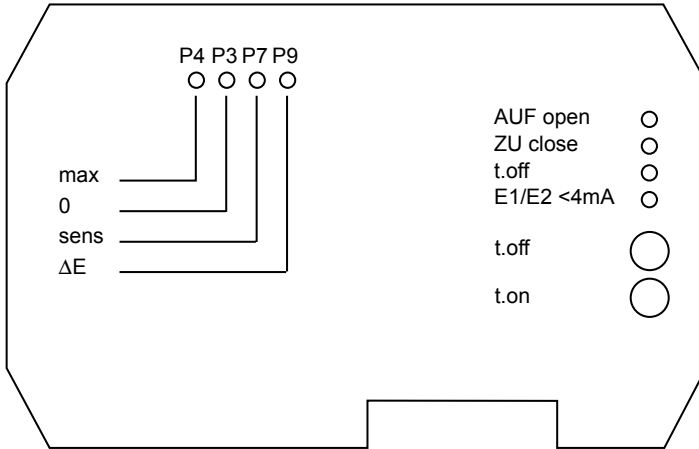

Fig. 13

4.5.1 Setting close positioner card input:

- Set selector switch to **LOCAL** position, on the control panel (**16** see Fig. 6).
- Connect mA input signal **E1** to terminals 2(+) and 3(-) in the plug/socket connector (**14**).
- Close valve by using the push button **I** to **close**.
- Supply input signal **E1** (nominal value) to 4 mA.
- Turn potentiometer (**t.off**) anticlockwise to the stop.
- Connect voltmeter (0-5 V) to measuring points MP3(+) and MP4(-):
For **E1** (nominal value) = 0 mA: measure 0 V.
For **E2** (nominal value) = 4 mA: measure 1 V.
- Connect voltmeter for measuring of actual value to measuring points MP2(+) and MP1(-).
For **E2** (actual value) = 4 mA: measure 1 V.
- If measured value is not correct adjust position feedback according to Section 4.4.

4.5.2 LED setting at closed position (see Fig. 13):-

LED's are not illuminated	Turn potentiometer P3 '0' slightly in a clockwise direction until the close LED (yellow) is on.
LED open (green) is illuminated	Turn potentiometer P3 '0' slightly in a clockwise direction until LED open (green) is off and LED close (yellow) is on.
LED close (yellow) is illuminated	Turn potentiometer P3 '0' in an anticlockwise direction until LED close (yellow) is off. Then turn potentiometer P3 '0' slightly in clockwise direction until LED close (yellow) is on again.

4.5.3 Setting open positioner card input:

- Open valve by using the push button  to **open**.
- Measure 5 V at measuring points MP2(+) and MP1(-).
- If measured value is not correct adjust the position of feedback according to Section 4.4.
- Supply max. input signal **E1** = (nominal values) to **20 mA**.
- Measure 5 V at measuring points MP3(+) and MP4(-). If measured value is not 5 V, check the input signal.

4.5.4 LED setting at open position (see Fig. 13):

LED's are not illuminated	Turn potentiometer P3 'max'. slightly in an anticlockwise direction until LED open (green) is on.
LED open (green) is illuminated	Turn potentiometer P4 'max'. in a clockwise direction until LED open (green) is off. Then turn potentiometer P4 'max' slightly in an anticlockwise direction until LED open (green) is on again.
LED close (yellow) is illuminated	Turn potentiometer P4 'max'. slightly in an anticlockwise direction until LED close (yellow) is off and LED open (green) is on.

Repeat 4.5.1, 4.5.2, 4.5.3 and 4.5.4 to check the setting's are correct.

Set selector switch to **REMOTE** position, on the control panel (16 see Fig. 6). Vary the mA signal **E1** through the 4-20 mA range, and check this matches the travel position on the actuator.

4.5.5 Setting sensitivity:

- Set selector switch to **REMOTE** position.
- Supply input signal **E1** (4-20 mA).
- The sensitivity (ΔE /deadband) is set to maximum value (2.5%) as supplied.
- Turning potentiometer ΔE (P9) anticlockwise will reduce the deadband thus increasing the sensitivity. For precise setting of the sensitivity, a set point device with a resolution of 0.1 mA is required.

When setting ΔE the following must be observed:

If the number of starts is too high, this can lead to unnecessary wear of the valve and actuator. Therefore the highest possible sensitivity should be set.

4.5.6 Setting time delay

To avoid exceeding the maximum permissible number of starts in extreme cases, a time delay between 0.5 seconds (left stop) and 10 seconds (right stop) may be set by rotating potentiometer 't.off' (P10). Under normal circumstances 't.off' (P10) should be set to minimum delay of 0.5 seconds (left stop).

5. Maintenance



Always make sure that the electrical supply is switched off when carrying out maintenance on the actuator or valve.

Series A actuators are high quality electromechanical devices that require only little maintenance. To ensure reliable service, the following instructions should be observed.

Check the bolts between the valve and actuator for tightness approximately six months after commissioning and every year thereafter. If required, retighten.

If seldomly operated, perform a test run every six months as described in Section 4.1. This assures that the actuator is always ready to operate.

The following parts must be checked for tightness once every year:

- Switch compartment cover.
- Plug cover/terminal cover.
- Cable glands.
- If necessary, clean and apply thin film of non-acidic grease (e.g. Vaseline) to sealing faces. Fasten bolts evenly diagonally.

5.1 Lubrication maintenance

5.1.1 Gear housing grease

The gear housing is filled with lubricant at manufacture. This filling lasts for several years of service.

The maintenance intervals depend on:

- Average required torque in relation to maximum torque.
- Number of turns at the output shaft.
- Number of starts per hour for modulating actuators.

A grease change is recommended after the following operation times:

- If seldomly operated 10-12 years
- If operated frequently 6-8 years

5.1.2 Procedure for changing grease

Refer to the manufacturer's literature for this procedure.

5.1.3 Resetting limit switches

After an actuator has been removed from a valve the limit switches must be reset and a test run performed, refer to Section 4, 'Commissioning'.

5.2 A and AM spindle lubrication

The threaded spindle is lubricated with grease. This spindle will need regular cleaning and relubricating:

- Manually close the valve fully.
- Apply grease to the top end of the exposed spindle.
- Manually reciprocate the valve to draw the grease into the drive nut.

5.3 AR and ARM output drive

The linear output drive is a sealed unit and filled with grease as supplied, it does not therefore require any maintenance. **The drive should not be refilled with grease.**

6. Wiring diagrams

The following diagrams show wiring examples for the Series 'A' actuator.

Wiring for ARM10.1 3-22, ARM14.1 3-22

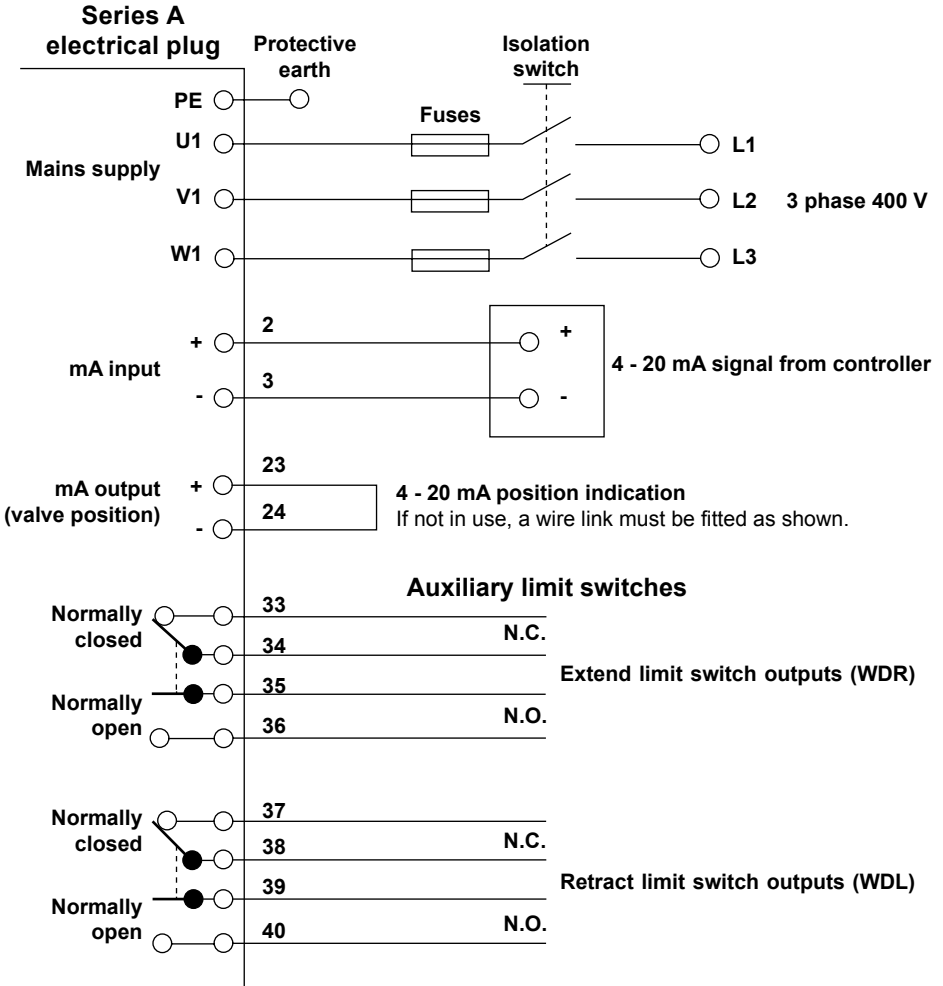

Fig. 14

Wiring for ARM10.1 1-22

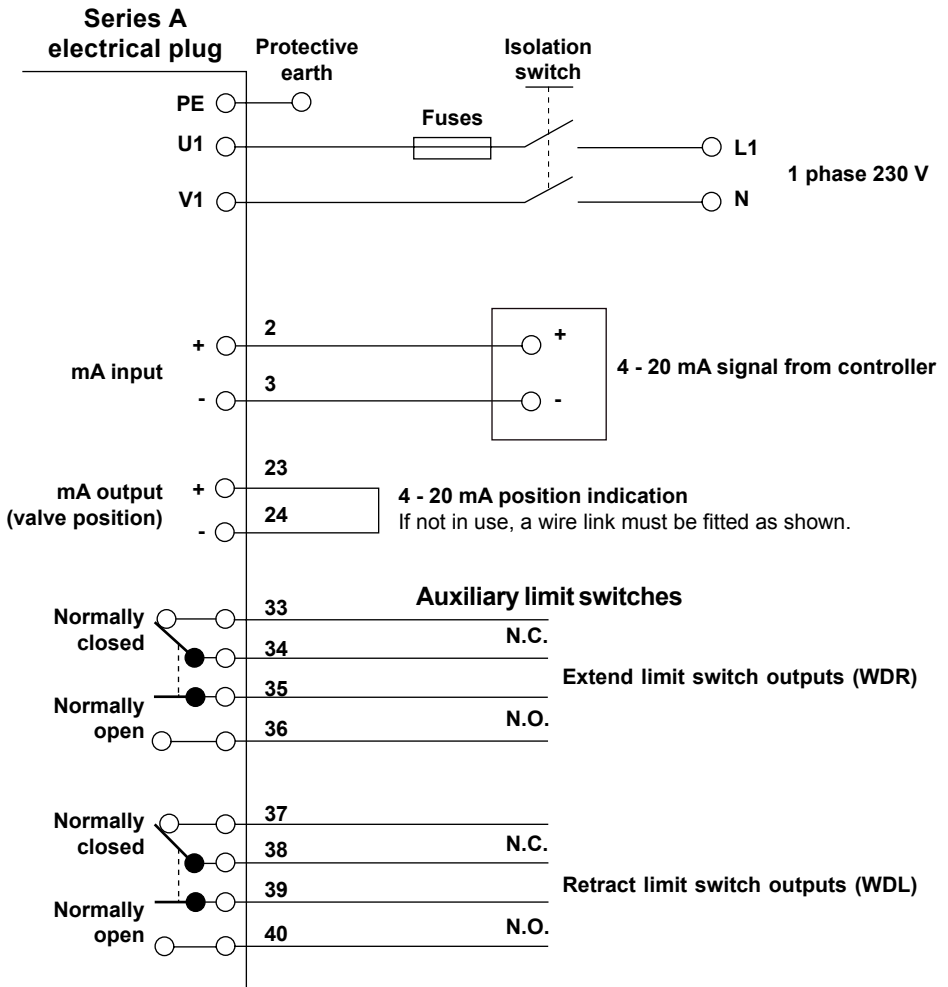

Fig. 15

Wiring for AM10.1 3-22, AM14.1 3-22

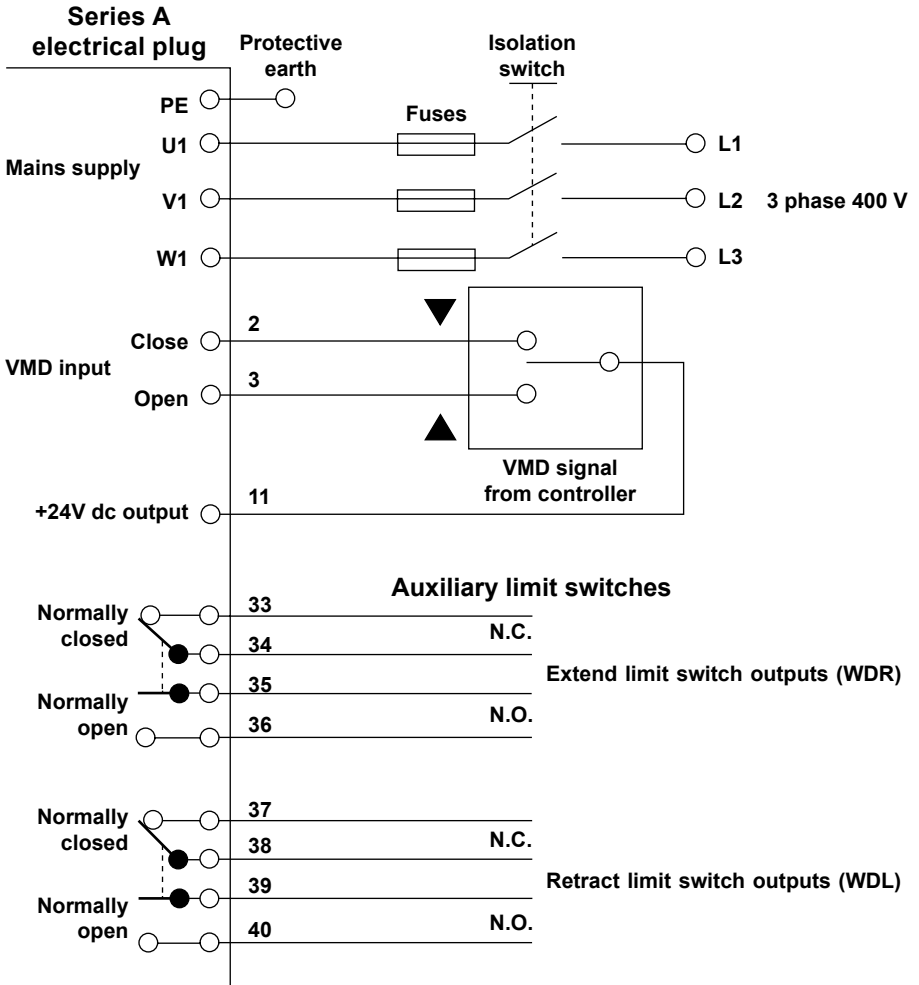

Fig. 16

Wiring for AM10.1 1-22

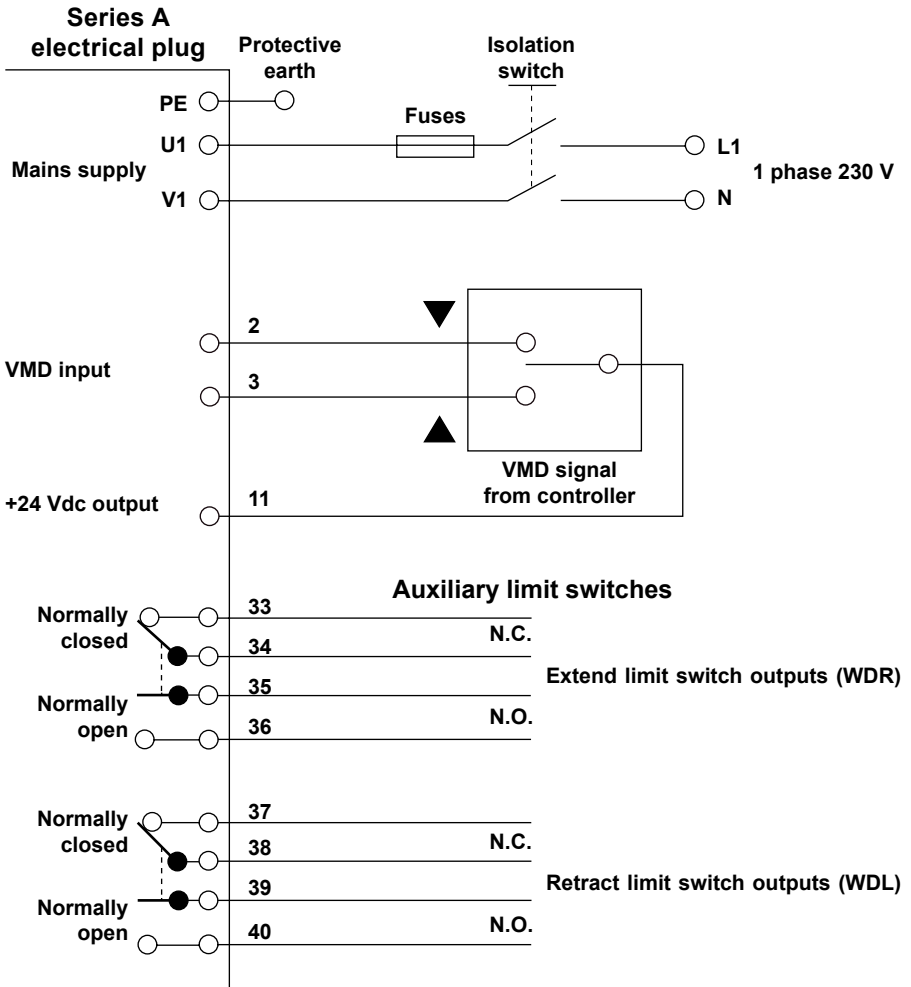

Fig. 17

Wiring for A10.1 3-22, A14.1 3-22

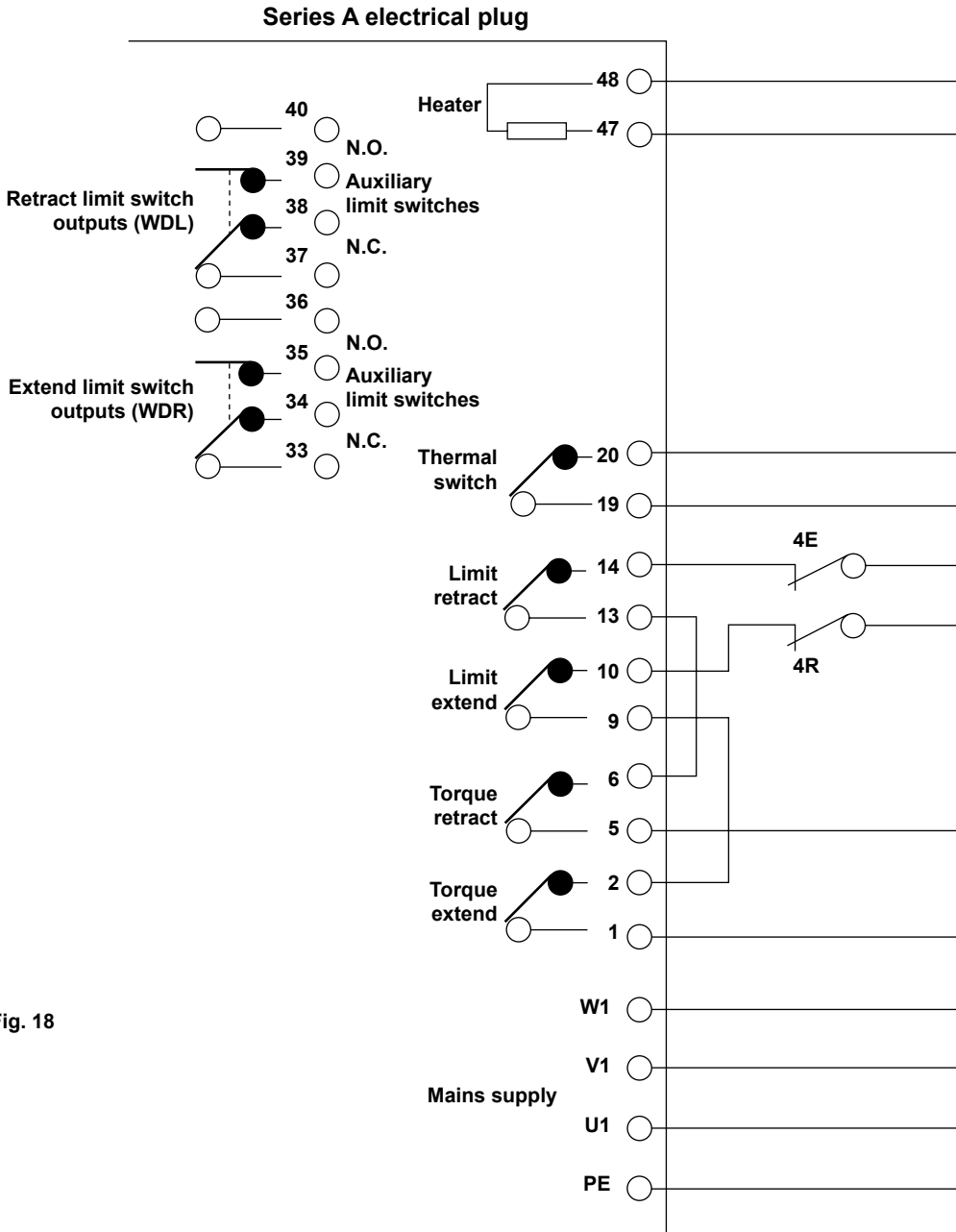
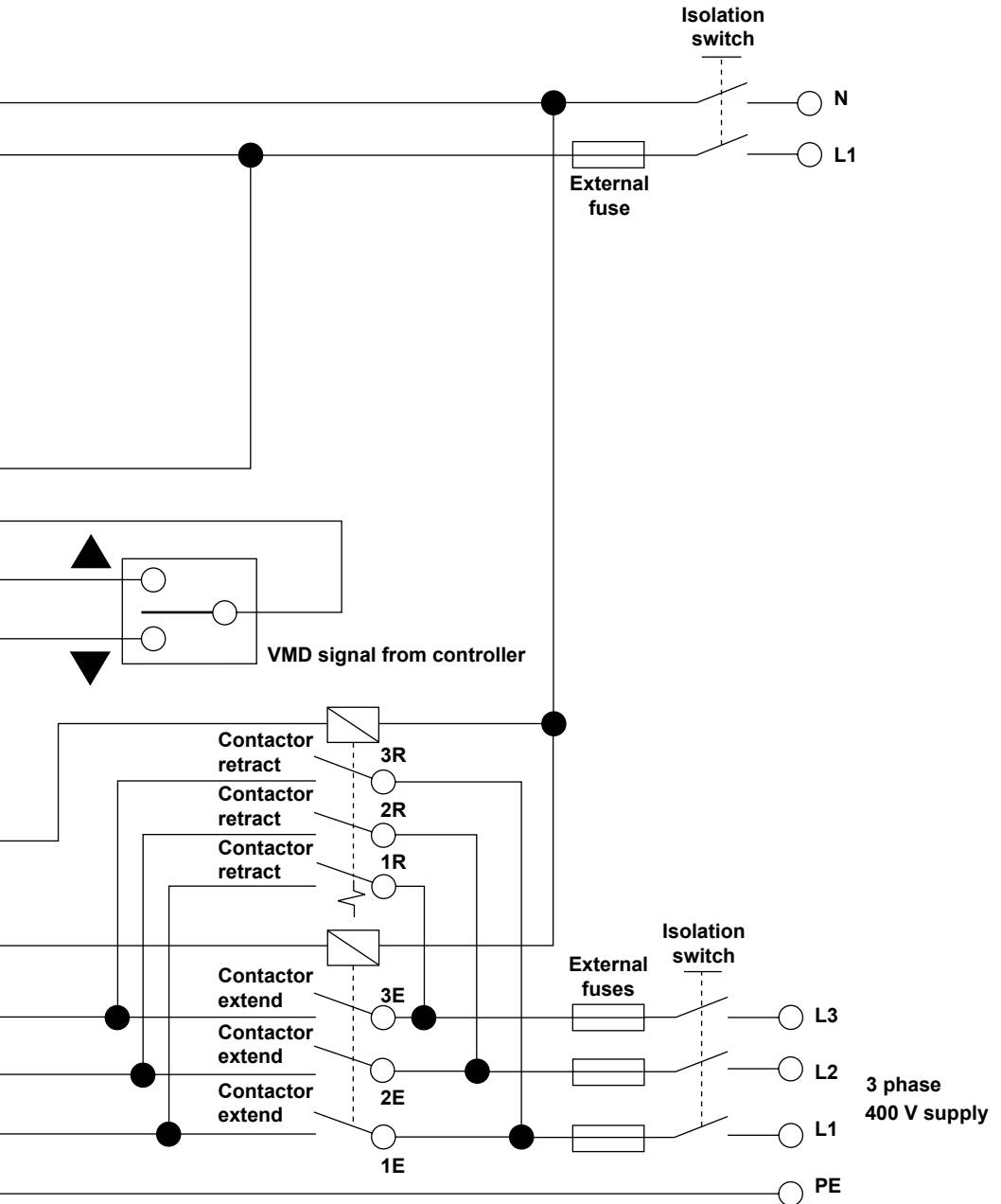
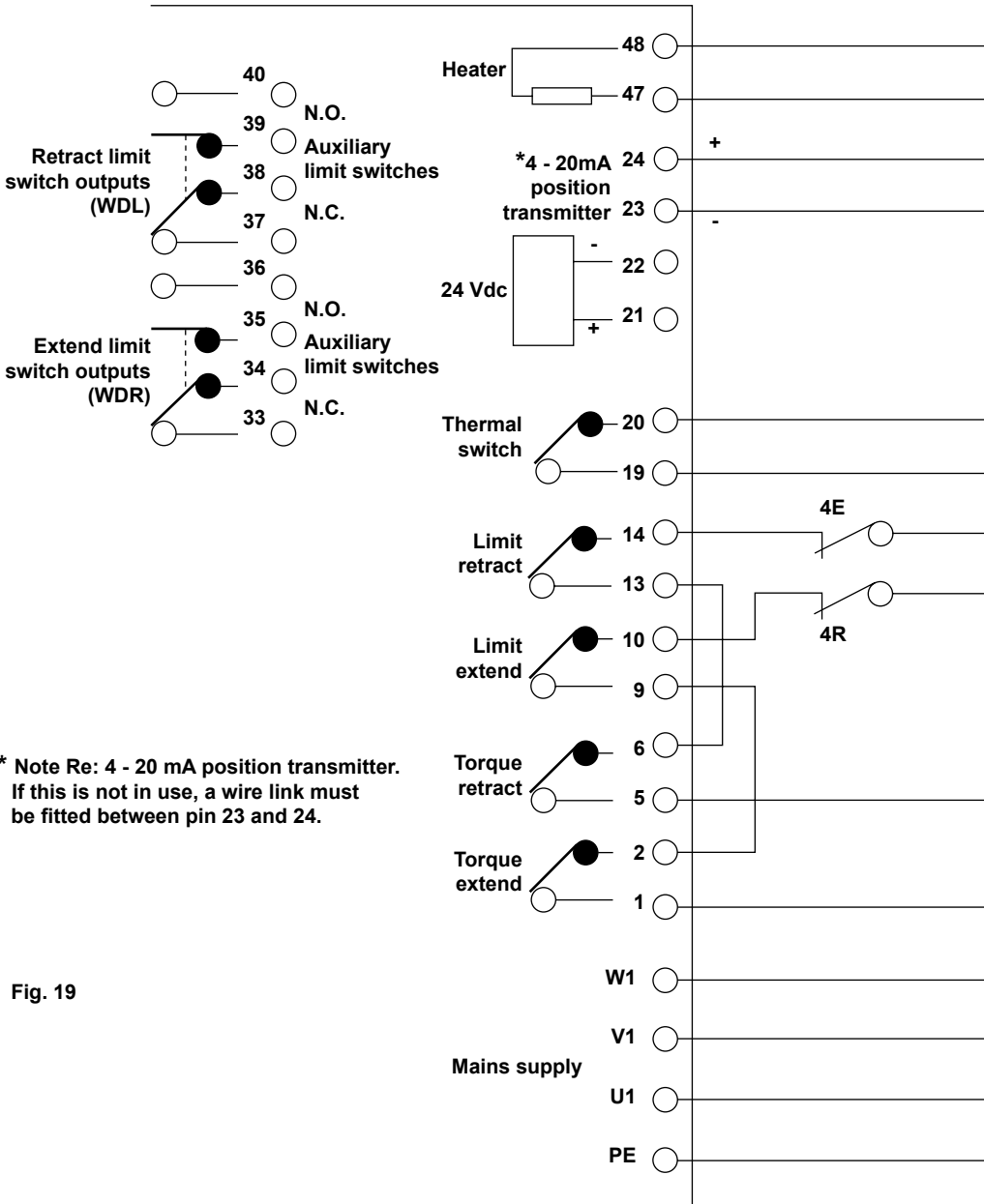

Fig. 18



Wiring for AR10.1 3-22, AR14.1 3-22

Series A electrical plug



* Note Re: 4 - 20 mA position transmitter. If this is not in use, a wire link must be fitted between pin 23 and 24.

Fig. 19

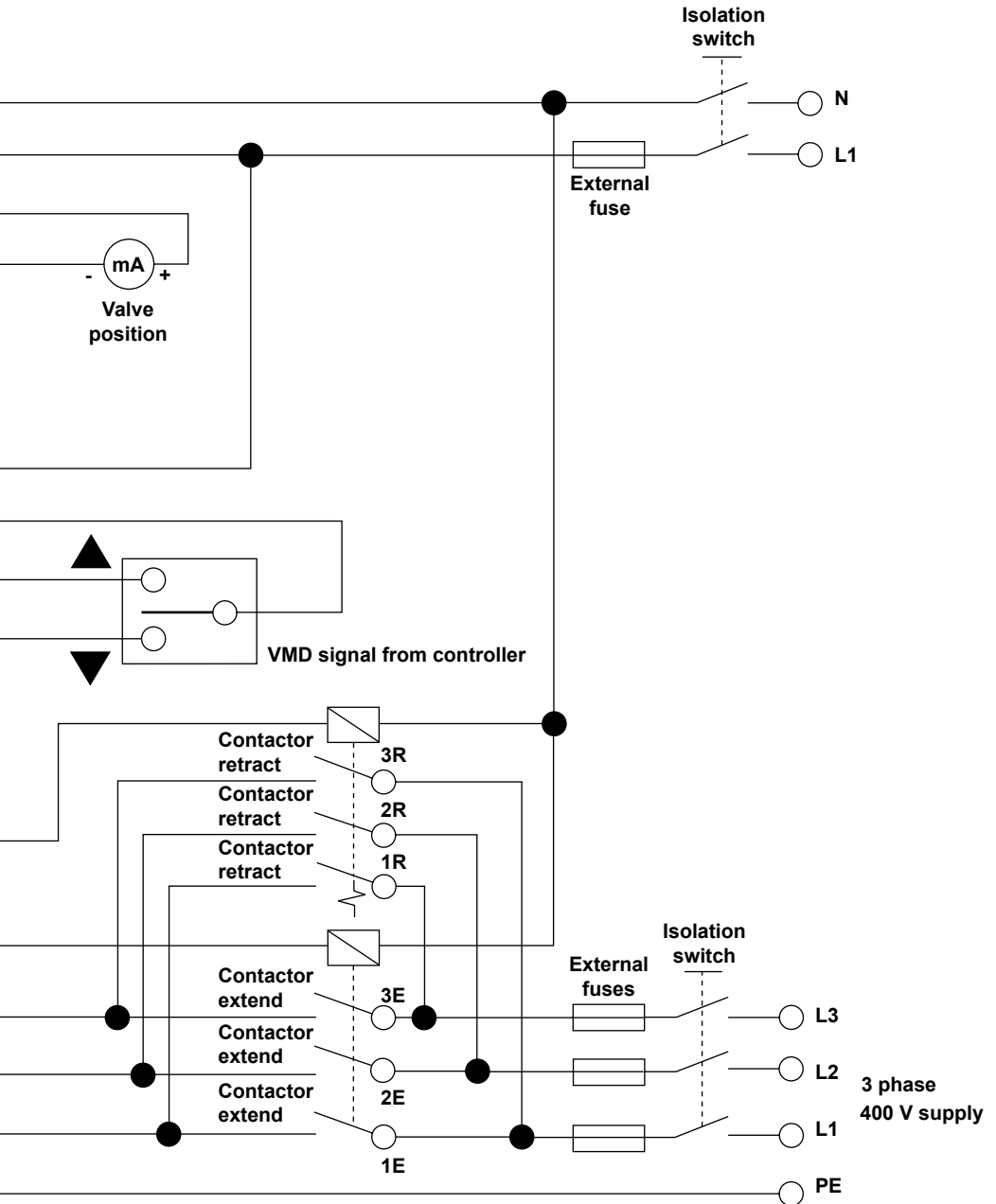

Wiring for A10.1 1-22

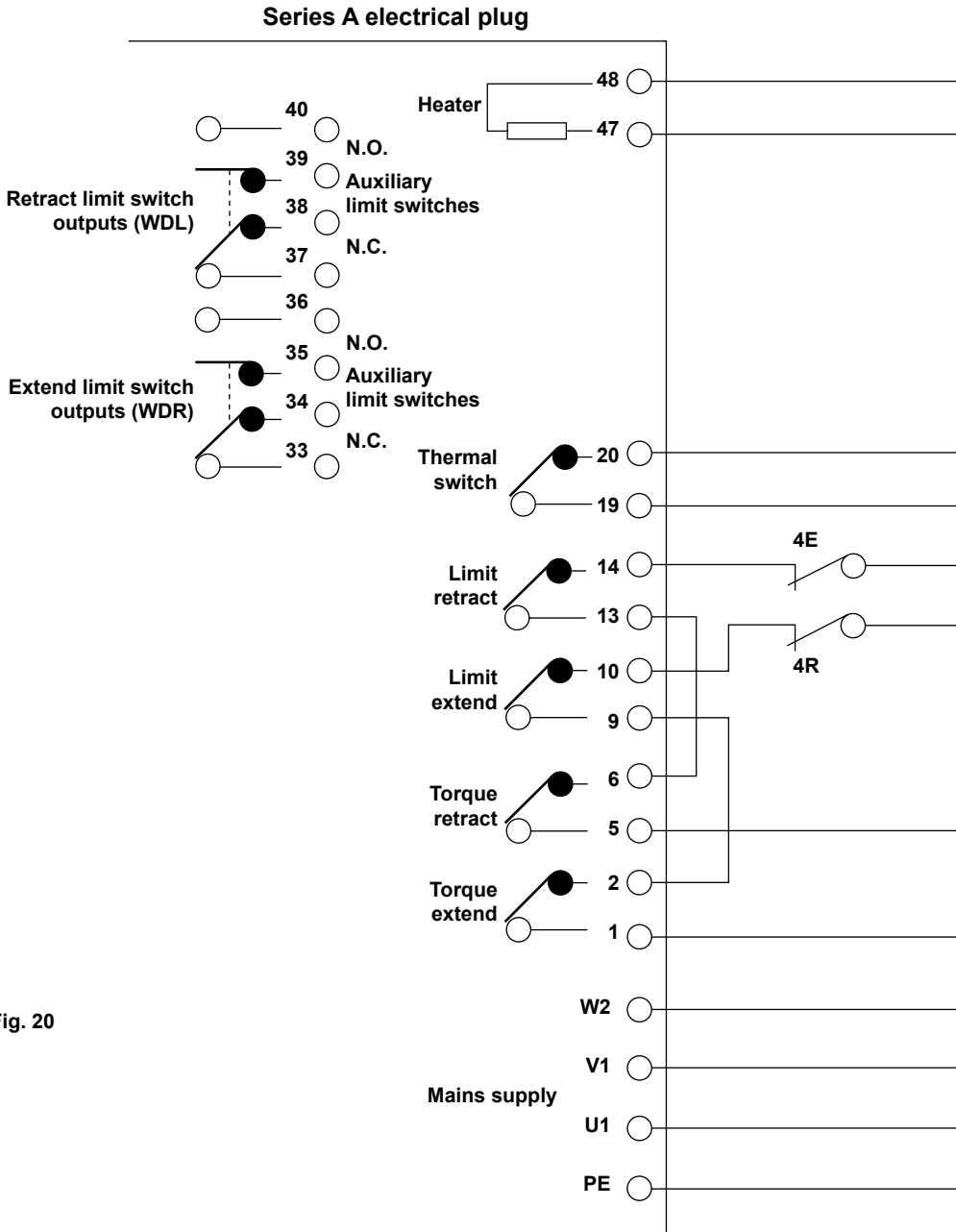
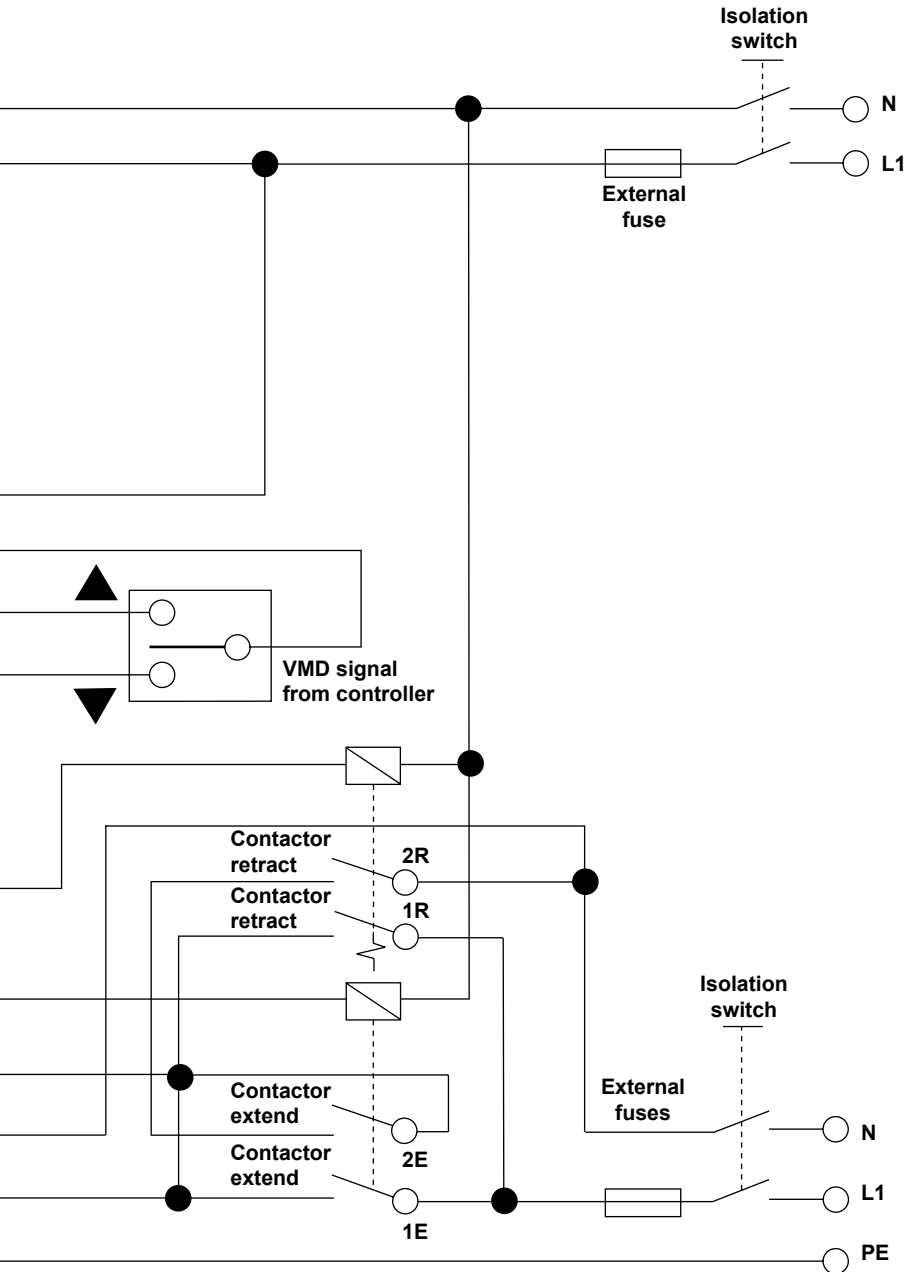

Fig. 20



1 phase
230 Vac
supply

Wiring for AR10.1 1-22

Series A electrical plug

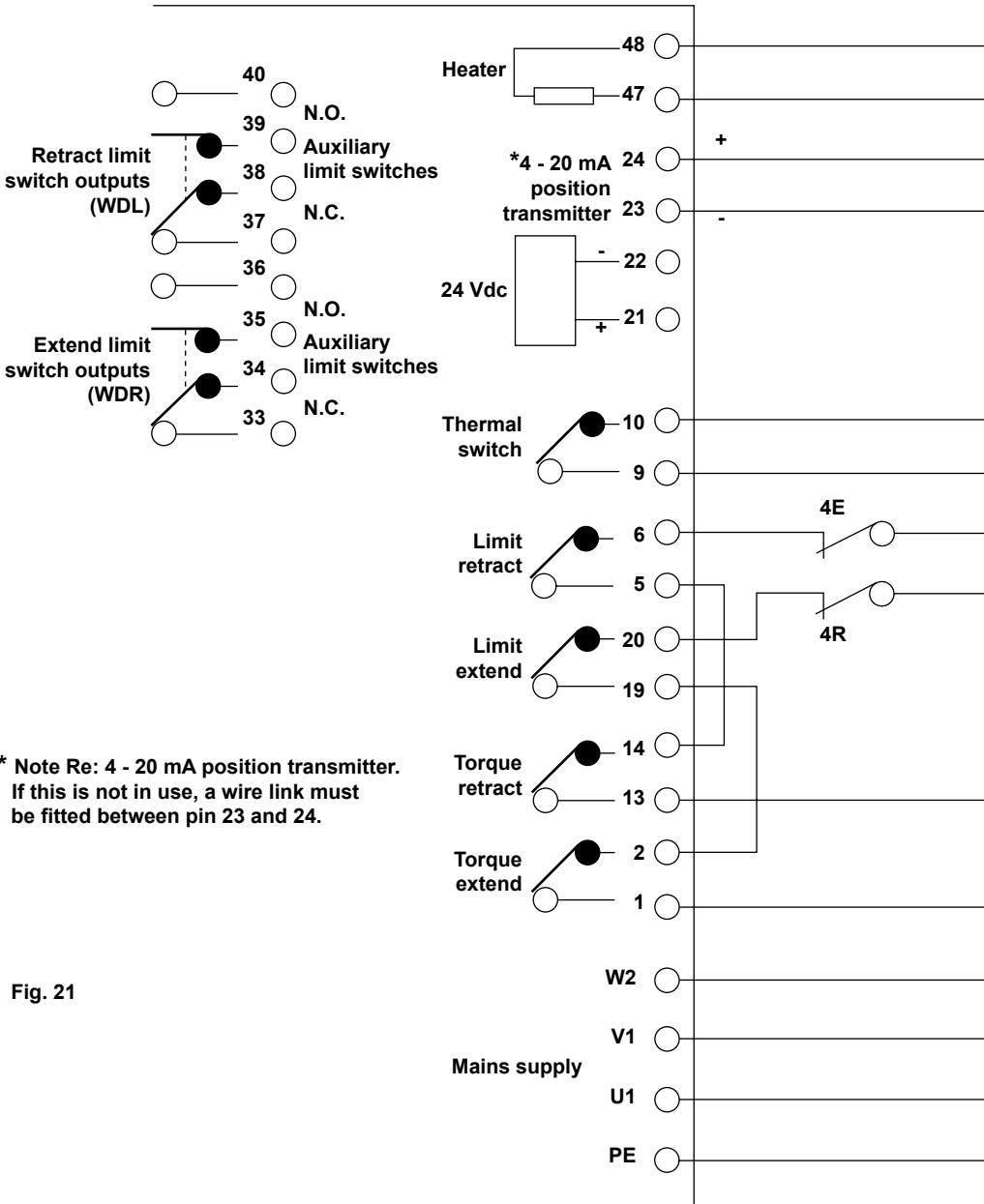

* Note Re: 4 - 20 mA position transmitter. If this is not in use, a wire link must be fitted between pin 23 and 24.

Fig. 21

