

SA121, SA122, SA128 and SA1219 Self-acting Temperature Control Systems (Dial Adjustment)

Installation and Maintenance Instructions

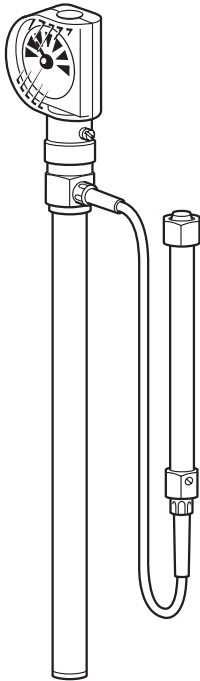

1. Safety information
2. Use
3. Installation
4. Pre-commissioning checks
5. Display adjustment
6. Commissioning
7. Decommissioning
8. Maintenance and spare parts

1. Safety information

Safe operation of these products can only be guaranteed if they are properly installed, commissioned, used and maintained by qualified personnel (see Section 1.11) in compliance with the operating instructions. General installation and safety instructions for pipeline and plant construction, as well as the proper use of tools and safety equipment must also be complied with. These products are designed and constructed to withstand the force encountered in normal use. Use of these products for any purpose other than as temperature controllers could cause injury or fatality to personnel.

1.1 Intended use

Referring to the Installation and Maintenance Instructions, name-plate and Technical Information Sheet, check that the product is suitable for the intended use/application. The products comply with the requirements of the EU Pressure Equipment Directive/UK Pressure Equipment (Safety) Regulations and fall within category 'SEP'.

It should be noted that products within this category are required by the directive not to carry the  mark.

- i) The products have been specifically designed for use on steam, water, compressed air and other non-hazardous fluids which are in Group 2 of the above mentioned Pressure Equipment Directive. The products' use on other fluids may be possible but, if this is contemplated, Spirax Sarco should be contacted to confirm the suitability of the product for the application being considered.
- ii) Check material suitability, pressure and temperature and their maximum and minimum values. If the maximum operating limits of the product are lower than those of the system in which it is being fitted, or if malfunction of the product could result in a dangerous overpressure or overtemperature occurrence, ensure a safety device is included in the system to prevent such over-limit situations.
- iii) Determine the correct installation situation and direction of fluid flow.
- iv) Spirax Sarco products are not intended to withstand external stresses that may be induced by any system to which they are fitted. It is the responsibility of the installer to consider these stresses and take adequate precautions to minimise them.
- v) Remove protection covers from all connections and protective film from all name-plates, where appropriate, before installation on steam or other high temperature applications.

1.2 Access

Ensure safe access and if necessary a safe working platform (suitably guarded) before attempting to work on the product. Arrange suitable lifting gear if required.

1.3 Lighting

Ensure adequate lighting, particularly where detailed or intricate work is required.

1.4 Hazardous liquids or gases in the pipeline

Consider what is in the pipeline or what may have been in the pipeline at some previous time. Consider: flammable materials, substances hazardous to health, extremes of temperature.

Warning: The sensor must not be subjected to mercury or ammonium salts.

1.5 Hazardous environment around the product

Consider: explosion risk areas, lack of oxygen (e.g. tanks, pits), dangerous gases, extremes of temperature, hot surfaces, fire hazard (e.g. during welding), excessive noise, moving machinery.

1.6 The system

Consider the effect on the complete system of the work proposed. Will any proposed action (e.g. closing isolation valves, electrical isolation) put any other part of the system or any personnel at risk?

Dangers might include isolation of vents or protective devices or the rendering ineffective of controls or alarms. Ensure isolation valves are turned on and off in a gradual way to avoid system shocks.

1.7 Pressure systems

Ensure that any pressure is isolated and safely vented to atmospheric pressure. Consider double isolation (double block and bleed) and the locking or labelling of closed valves. Do not assume that the system has depressurised even when the pressure gauge indicates zero.

1.8 Temperature

Allow time for temperature to normalise after isolation to avoid the danger of burns.

1.9 Tools and consumables

Before starting work ensure that you have suitable tools and/or consumables available. Use only genuine Spirax Sarco replacement parts.

1.10 Protective clothing

Consider whether you and/or others in the vicinity require any protective clothing to protect against the hazards of, for example, chemicals, high/low temperature, radiation, noise, falling objects, and dangers to eyes and face.

1.11 Permits to work

All work must be carried out or be supervised by a suitably competent person.

Installation and operating personnel should be trained in the correct use of the product according to the Installation and Maintenance Instructions.

Where a formal 'permit to work' system is in force it must be complied with. Where there is no such system, it is recommended that a responsible person should know what work is going on and, where necessary, arrange to have an assistant whose primary responsibility is safety.

Post 'warning notices' if necessary.

1.12 Handling

Manual handling of large and/or heavy products may present a risk of injury. Lifting, pushing, pulling, carrying or supporting a load by bodily force can cause injury particularly to the back. You are advised to assess the risks taking into account the task, the individual, the load and the working environment and use the appropriate handling method depending on the circumstances of the work being done.

1.13 Residual hazards

In normal use the external surface of the product may be very hot. If used at the maximum permitted operating conditions the surface temperature of some products may reach temperatures of 215 °C (419 °F).

Many products are not self-draining. Take due care when dismantling or removing the product from an installation (refer to 'Maintenance instructions').

WARNING: This product contains kerosene which is highly inflammable.

1.14 Freezing

Provision must be made to protect products which are not self-draining against frost damage in environments where they may be exposed to temperatures below freezing point.

1.15 Disposal

Unless otherwise stated in the Installation and Maintenance Instructions, this product is recyclable and no ecological hazard is anticipated with its disposal providing due care is taken.

1.16 Returning products

Customers and stockists are reminded that under EC Health, Safety and Environment Law, when returning products to Spirax Sarco they must provide information on any hazards and the precautions to be taken due to contamination residues or mechanical damage which may present a health, safety or environmental risk. This information must be provided in writing including Health and Safety data sheets relating to any substances identified as hazardous or potentially hazardous.

2. Use

It is important that these self-acting temperature control systems are only used with Spirax Sarco control valves as indicated in Table 1:

Table 1

Self-acting temperature control system	Control valve size	Control valve type
SA121	All	2-port
	¾" to 2"	TW
SA128, SA122	½" to 1"	2-port
	¾" and 1"	TW
SA1219	3" and 4"	TW

SA121, SA122, SA128 and SA1219 Self-acting Temperature Control Systems (Dial Adjustment)

3. Installation

These product are designed and constructed to withstand the force encountered in normal use. Use of these products for any purpose other than as temperature controllers could cause injury or fatality to personnel.

Warning: The sensor must not be subjected to mercury or ammonium salts.

Check that the control system supplied is of the temperature range required. It is important that the whole of the temperature sensing area of the sensor is fully immersed in the fluid being controlled, see Figure 1.

The sensors can be held in a screwed nipple by means of a compression ring. Screw the nipple into the boss provided on the plant, thread the union nut and compression ring over the sensor. Insert the sensor fully into the nipple and tighten up the nut and compression ring. **Do not overtighten.**

Where the sensors are used in conjunction with a pocket, either to allow easy withdrawal or as a protection against corrosion, the separate screwed nipple is dispensed with and the union nut and compression ring attached directly to the top of the pocket. Therefore insert the pocket in place of the screwed nipple.

When using a special long pocket with the SA122 sensor, the screwed nipple, compression ring and nut are dispensed with and a rubber sealing bung provided, which is fitted over the capillary and slid into place to secure the sensor into the pocket. Screw the pocket into place, then feed the sensor bulb to the bottom of the pocket, using the rubber bung to seal the top.

When using a pocket it is advisable to fill the gap between the pocket and the sensor with a heat conducting medium such as oil, but when using a special long pocket in conjunction with the SA122 sensors it should not be filled above the top of the sensor.

The adjustment mechanism should not be subjected to an ambient temperature above 50 °C (122 °F) or below -35 °C (-31 °F). The capillary tube between the sensor and the valve must be run and supported in such a way that it will not become damaged. Avoid all sharp bends. See Sections 5 and 6 'Display adjustment' and 'Commissioning'.

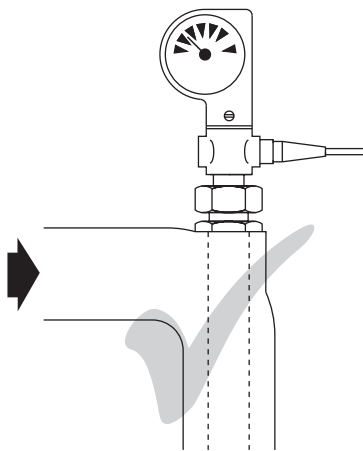

Correct installation

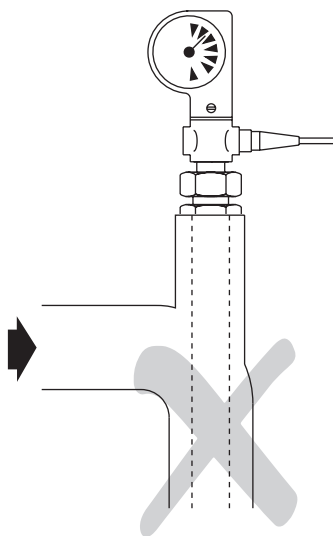

Incorrect installation

Fig. 1

4. Pre-commissioning checks

These temperature control systems have been designed and manufactured to the highest industrial standards. In order that they function correctly, please observe the following points and then proceed with the 'Display adjustment' in Section 5 for adjusting to the desired set temperature.

4.1 Factory temperature setting

In order to avoid accidental damage due to exposure of extreme temperatures, the unit is factory adjusted to its highest set temperature. This value will vary according to the data shown in Table 2.

4.2 Overtemperature protection

In the event that the overtemperature protection is exceeded by the values shown, serious damage will occur and the warranty will be invalidated. Before commissioning this unit, please ensure that the system temperature cannot exceed the overtemperature protection value.

Table 2

Metric				
Self-acting temperature control system	Range no.	Temperature adjustment range (°C)	Factory setting	Overtemperature protection
SA121 and SA1219	1	-15 to +50	50 °C	55 °C over set value to 190 °C maximum
	2	+40 to +105	105 °C	
	3	+95 to +160	160 °C	
SA122	1	-20 to +120	120 °C	
	2	+40 to +170	170 °C	
SA128	1	-20 to +110	110 °C	
	2	+40 to +170	170 °C	
Imperial				
Self-acting temperature control system	Range no.	Temperature adjustment range (°C)	Factory setting	Overtemperature protection
SA121 and SA1219	1	+5 to +125	125 °F	130 °F over set value to 374 °F maximum
	2	+105 to +225	225 °F	
	3	+205 to +325	325 °F	
SA122	1	-5 to +240	240 °F	
	2	+106 to +340	340 °F	
SA128	1	-5 to +230	230 °F	
	2	+106 to +340	340 °F	

5. Operation

The display of the self-acting temperature control may be adjusted to suit your specific requirements.

The adjustments include:-

Selection of °C or °F - Section 5.1.

Rotation of the temperature scale - Section 5.2.

Rotation of the dial head - Section 5.3

5.1 Selection of °C or °F

For the following instructions you should make reference to Figure 2 except where stated:-

1. Remove the tamper-proof plug (6) and use a suitable screwdriver to set the indicator (3) to the midway mark (1).
2. Remove the transparent cover (2).
3. Remove the temperature indicator (3).
4. Remove the temperature indicator scale (4) and select °C or °F (Double sided) as required (Figure 3) and replace.
5. Replace the indicator to the midway position (1).
6. Replace the transparent cover (2).

This self-acting temperature control is now ready for commissioning as detailed in Section 6.

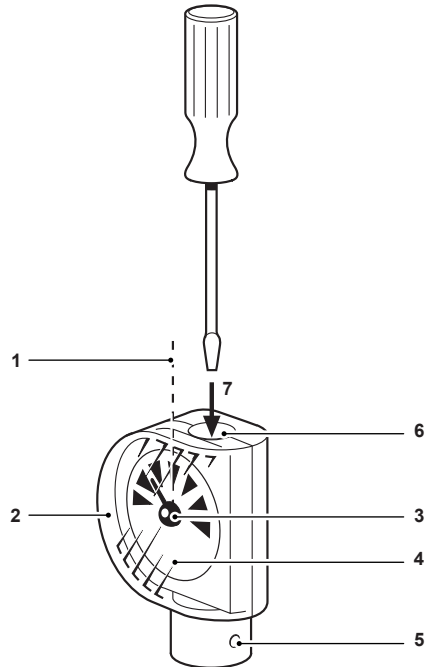

Fig. 2a

5.2 Rotating the temperature scale

In some instances it may be necessary to rotate the scale to make the set temperature more easily read. In such cases the following procedure should be adopted making reference to Figure 2b and Figure 4 except where stated:

1. Remove the tamper-proof plug (6) and use a suitable screwdriver to set the indicator (3) to the midway point (1).
2. Remove the transparent cover (2).
3. Remove the indicator (3).
4. Remove the scale (4) from the indicator and relocate to the desired position i.e. Figure 4.
5. Replace the indicator (3) to the midway point of the scale (1).
6. Replace the transparent cover (2).

This self-acting temperature control is now ready for commissioning as detailed in Section 6.

5.3 Rotating the dial head

The dial head itself may be rotated through 180 ° if necessary. In such cases the following procedure should be adopted making reference to Figure 2b and Figure 5 except where stated:

1. Remove the tamper-proof plug (6) and use a suitable screwdriver to set the indicator (3) to the midway point (1).
2. Remove the transparent cover (2).
3. Remove the indicator (3).
4. Remove the dial head retaining screws (5).
5. Rotate the indicator through 180 ° (Figure 5).
6. Replace the dial head retaining screws (5).
7. Replace the indicator to the midway point and replace the transparent cover and tamper-proof plug.

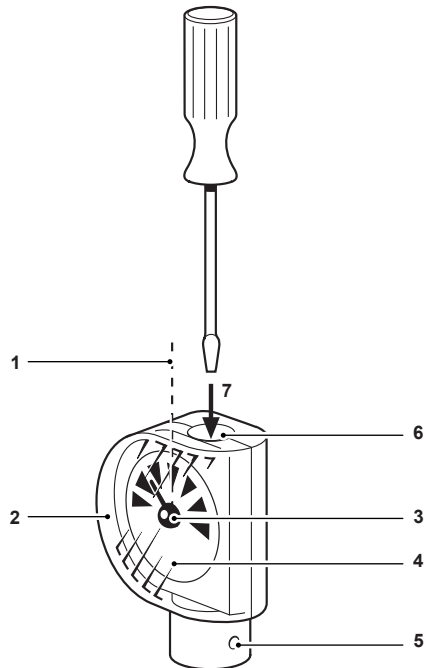

Fig. 2b

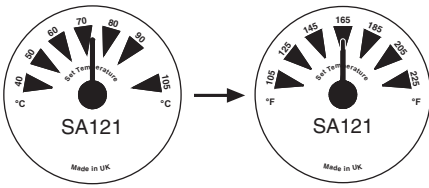

Fig. 3
Selection of temperature scale °C or °F

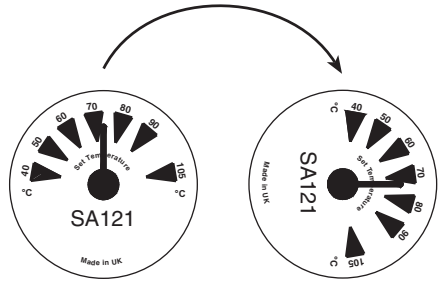

Fig. 4
Rotation of the temperature scale

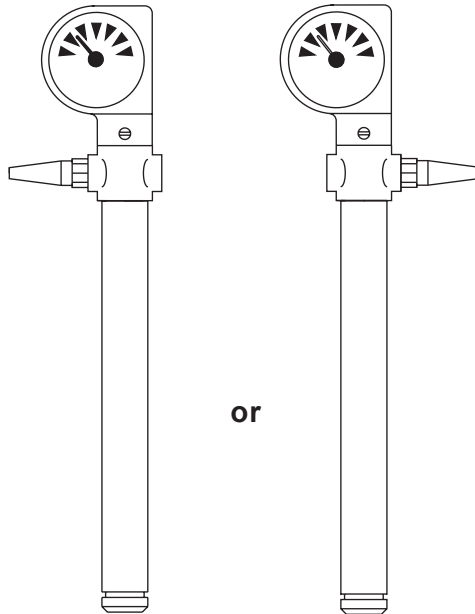

Fig. 5
Rotation of the dial head

6. Commissioning

For the following instructions you should make reference to Figure 6. The sensor should be set on site to the midway mark (1). Make any adjustments to the desired setting with a suitably sized screwdriver engaged in the adjustment drive (7) on the end of the indicator dial. Turning clockwise will lower the temperature, anticlockwise will increase it. After setting the plant to work, compare the thermometer reading with the scale reading on the temperature control reading.

This may be found to differ by a few degrees, if precise control is required it can be adjusted by resetting the scale as follows:

1. Remove the transparent front cover (2) of the indicator head and turn the indicator (3) manually until it corresponds to the actual temperature.
2. Replace the transparent cover (2).
3. Reset the set temperature to the desired temperature.
4. Replace the transparent cover and tamper-proof plug.

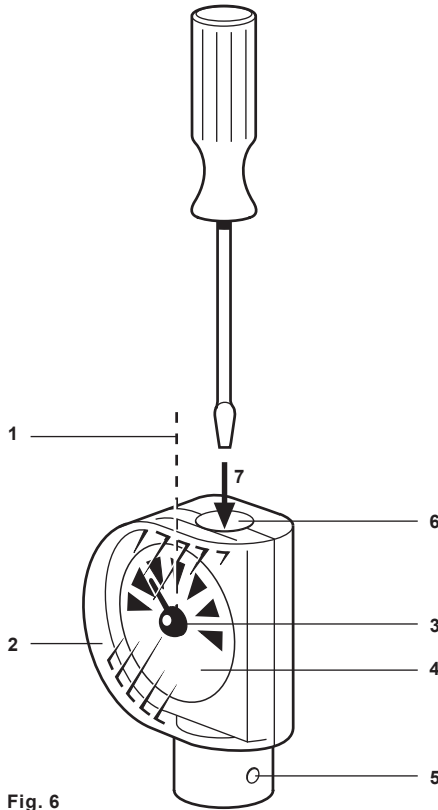

Fig. 6

7. Decommissioning

As a safety precaution, if the unit is to be decommissioned, it is important to reset the unit to its maximum (factory) setting before reinstalling.

8. Maintenance and spare parts

There are no serviceable parts.

