

PN1000 and PN2000
Pneumatic Actuators
Installation and Maintenance Instructions

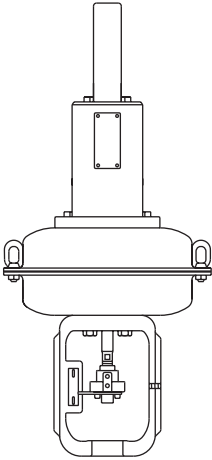

PN1000

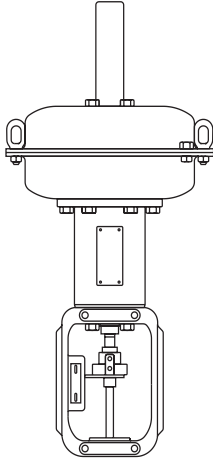

PN2000

- 1. Safety information
- 2. General product information
- 3. Installation
- 4. Commissioning
- 5. Maintenance
- 6. Fault finding

1. Safety information

Safe operation of these products can only be guaranteed if they are properly installed, commissioned, used and maintained by qualified personnel (see Section 1.11) in compliance with the operating instructions. General installation and safety instructions for pipeline and plant construction, as well as the proper use of tools and safety equipment must also be complied with.

1.1 Intended use

Referring to the Installation and Maintenance Instructions, name-plate and Technical Information Sheet, check that the product is suitable for the intended use/application. The products comply with the requirements of the European Pressure Equipment Directive 2014/68/EU and fall within category 'SEP'.

It should be noted that products within this category are required by the Directive not to carry the  mark.

- i) The products have been specifically designed for use on air or water, which are in Group 2 of the above mentioned Pressure Equipment Directive. The products' use on other fluids may be possible but, if this is contemplated, Spirax Sarco should be contacted to confirm the suitability of the product for the application being considered.
- ii) Check material suitability, pressure and temperature and their maximum and minimum values. If the maximum operating limits of the product are lower than those of the system in which it is being fitted, or if malfunction of the product could result in a dangerous overpressure or overtemperature occurrence, ensure a safety device is included in the system to prevent such over-limit situations.
- iii) Determine the correct installation situation and direction of fluid flow.
- iv) Spirax Sarco products are not intended to withstand external stresses that may be induced by any system to which they are fitted. It is the responsibility of the installer to consider these stresses and take adequate precautions to minimise them.
- v) Remove protection covers from all connections before installation.

1.2 Access

Ensure safe access and if necessary a safe working platform (suitably guarded) before attempting to work on the product. Arrange suitable lifting gear if required.

1.3 Lighting

Ensure adequate lighting, particularly where detailed or intricate work is required.

1.4 Hazardous liquids or gases in the pipeline

Consider what is in the pipeline or what may have been in the pipeline at some previous time. Consider: flammable materials, substances hazardous to health, extremes of temperature.

1.5 Hazardous environment around the product

Consider: explosion risk areas, lack of oxygen (e.g. tanks, pits), dangerous gases, extremes of temperature, hot surfaces, fire hazard (e.g. during welding), excessive noise, moving machinery.

1.6 The system

Consider the effect on the complete system of the work proposed. Will any proposed action (e.g. closing isolation valves, electrical isolation) put any other part of the system or any personnel at risk? Dangers might include isolation of vents or protective devices or the rendering ineffective of controls or alarms. Ensure isolation valves are turned on and off in a gradual way to avoid system shocks.

1.7 Pressure systems

Ensure that any pressure is isolated and safely vented to atmospheric pressure. Consider double isolation (double block and bleed) and the locking or labelling of closed valves. Do not assume that the system has depressurised even when the pressure gauge indicates zero.

1.8 Temperature

Allow time for temperature to normalise after isolation to avoid danger of burns.

1.9 Tools and consumables

Before starting work ensure that you have suitable tools and/or consumables available. Use only genuine Spirax Sarco replacement parts.

1.10 Protective clothing

Consider whether you and/or others in the vicinity require any protective clothing to protect against the hazards of, for example, chemicals, high/low temperature, radiation, noise, falling objects, and dangers to eyes and face.

1.11 Permits to work

All work must be carried out or be supervised by a suitably competent person. Installation and operating personnel should be trained in the correct use of the product according to the Installation and Maintenance Instructions. Where a formal 'permit to work' system is in force it must be complied with. Where there is no such system, it is recommended that a responsible person should know what work is going on and, where necessary, arrange to have an assistant whose primary responsibility is safety. Post 'warning notices' if necessary.

1.12 Handling

Manual handling of large and/or heavy products may present a risk of injury. Lifting, pushing, pulling, carrying or supporting a load by bodily force can cause injury particularly to the back. You are advised to assess the risks taking into account the task, the individual, the load and the working environment and use the appropriate handling method depending on the circumstances of the work being done.

1.13 Residual hazards

In normal use the external surface of the product may be very hot. If used at the maximum permitted operating conditions the surface temperature of some products may reach temperatures of 120 °C (248 °F).

Many products are not self-draining. Take due care when dismantling or removing the product from an installation (refer to 'Maintenance instructions').

1.14 Freezing

Provision must be made to protect products which are not self-draining against frost damage in environments where they may be exposed to temperatures below freezing point.

1.15 Disposal

Unless otherwise stated in the Installation and Maintenance Instructions, this product is recyclable and no ecological hazard is anticipated with its disposal providing due care is taken.

Please visit the Spirax Sarco product compliance web pages

<https://www.spiraxsarco.com/product-compliance>

for up to date information on any substances of concern that may be contained within this product.

Where no additional information is provided on the Spirax Sarco product compliance web page, this product may be safely recycled and/or disposed providing due care is taken. Always check your local recycling and disposal regulations.

1.16 Returning products

Customers and stockists are reminded that under EC Health, Safety and Environment Law, when returning products to Spirax Sarco they must provide information on any hazards and the precautions to be taken due to contamination residues or mechanical damage which may present a health, safety or environmental risk. This information must be provided in writing including Health and Safety data sheets relating to any substances identified as hazardous or potentially hazardous.

2. General product information

2.1 Description

A range of single spring linear actuators having 5 diaphragm sizes for matching the requirements of different valves at various differential pressures. Each actuator is fitted with a combined mechanical stroke indicator and anti-rotation guard. The actuators are designed for easy conversion from spring-extend to spring-retract, and vice versa, without the need for special tools. The PN1000 and PN2000 actuators are designed to be used with C series 2-port control valves. A limited range is also available for use with the KE and KEA valves.

2.2 Available types

Spring-extend spindle actuators: **PN1300, PN1400, PN1500, PN1600 and PN1700 series**

Spring-retract spindle actuators: **PN2300, PN2400, PN2500, PN2600 and PN2700 series**

2.3 Technical data

Temperature range		-20 °C to +110 °C	(-4 °F to +230 °F)
Maximum operating pressure	PN1000 series	4.5 bar	(65 psi)
	PN2000 series	3.0 bar	(44 psi)
Air supply connection	PN1300 to PN1600 and PN2300 to PN2600		¼" NPT
	PN1700 and PN2700		½" NPT

2.4 Materials - PN1000

No.	Part	Material
1	Diaphragm housing	Carbon steel
2	Diaphragm	Reinforced nitrile rubber
3	Diaphragm plate	Stainless steel
4	Spring	Spring steel
5	Spindle guide	Bronze
6	DU bearing	Hardened steel
7	Yoke	Cast steel
8	Housing securing nuts and bolts	Zinc plated steel
9	Spindle	Stainless steel
10	Connector	Zinc plated steel
11	Travel indicator/anti-rotation device	Stainless steel
12	Connector locking screws	Zinc plated steel
13	'O' ring	Nitrile rubber
14	Lock-nut	Zinc plated steel
15	Cap with vent hole	Nickel plated brass
16	Spring guide	Zinc plated steel
17	Valve spindle adapter	Stainless steel

Fig. 1 PN1000 series

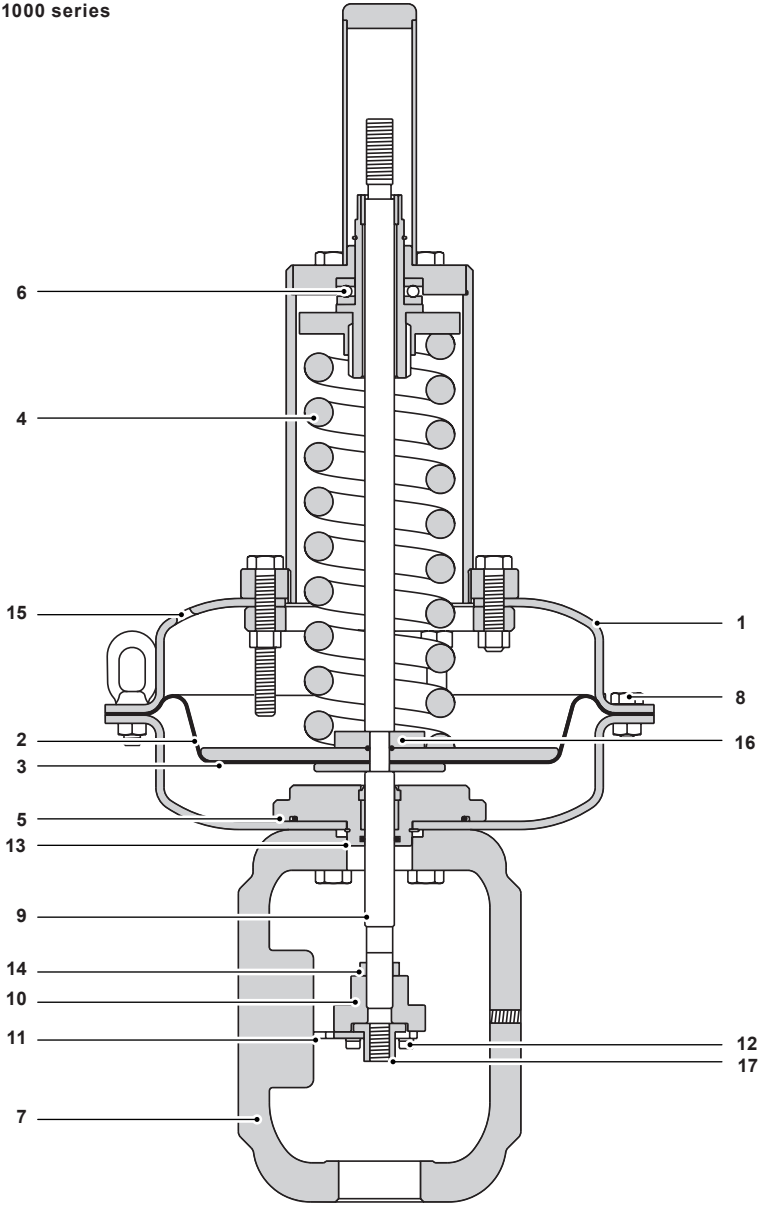

2.5 Materials - PN2000

No.	Part	Material
1	Diaphragm housing	Carbon steel
2	Diaphragm	Reinforced nitrile rubber
3	Diaphragm plate	Stainless steel
4	Spring	Spring steel
5	Spindle guide	Bronze
6	DU bearing	Hardened steel
7	Yoke	Cast steel
8	Housing securing nuts and bolts	Zinc plated steel
9	Spindle	Stainless steel
10	Connector	Zinc plated steel
11	Travel indicator/anti-rotation device	Stainless steel
12	Connector locking screws	Zinc plated steel
13	'O' ring	Nitrile rubber
14	Lock-nut	Zinc plated steel
15	Cap with vent hole	Nickel plated brass
16	Spring guide	Zinc plated steel
17	Valve spindle adapter	Stainless steel

Fig. 2 PN2000 series

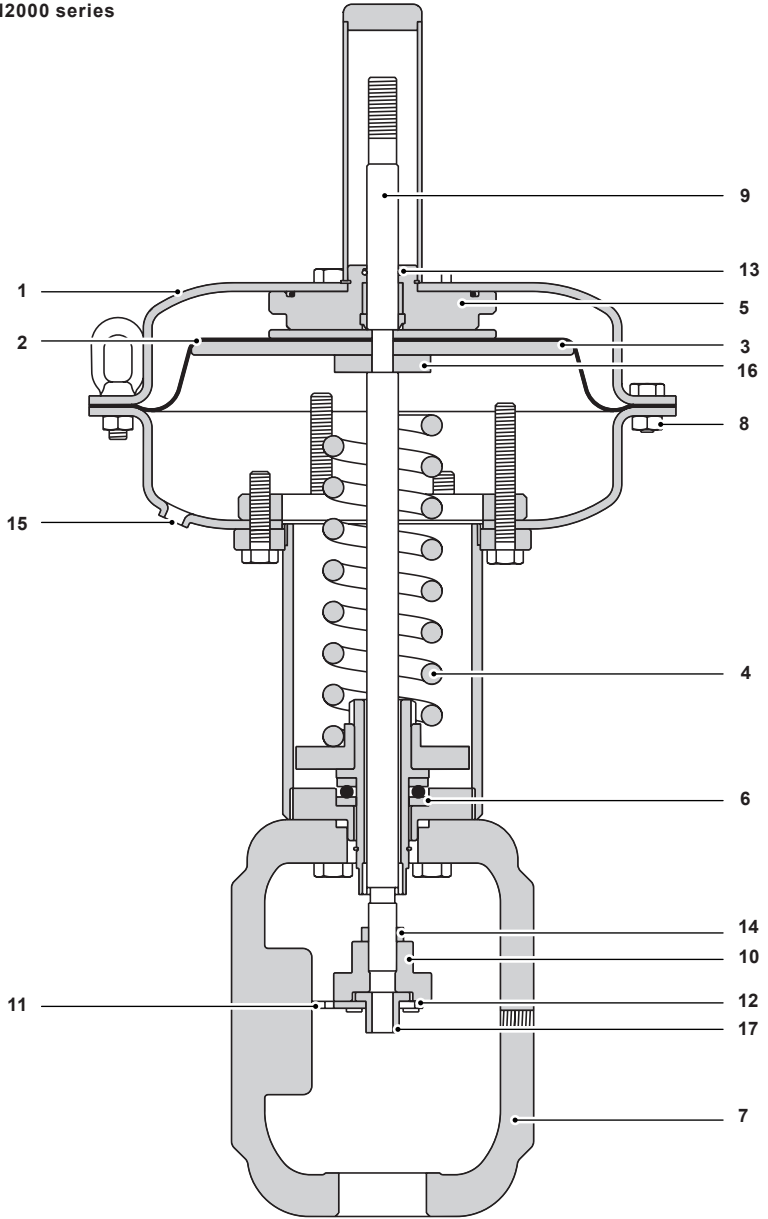

3. Installation

Note: Before actioning any installation observe the 'Safety information' in Section 1.
See separate Installation and Maintenance Instructions for the appropriate control valve.

3.1 General information

Actuators should be installed in such a position as to allow full access to both actuator and valve for maintenance purposes. The preferred mounting position is with the actuator and valve spindle in the vertical position above or below the horizontal pipework.
The actuator ambient limits are -4°F to +230°F (-20 °C to +110 °C). For low temperature conditions the air supply must be dry. For high temperature conditions, insulate the control valve and pipework to protect the actuator.

Warning:

The actuator housing must only be pressurised on the opposite side of the diaphragm to the springs. The housing vent cap must be left unrestricted.

3.2 Fitting the PN1000 spring-to-extend series actuator to the valve (Refer to Figures 3 and 4):

- Loosen and remove connector locking screws (12) and remove the anti-rotation plate (11).
- Fit the valve spindle adaptor (17) onto the valve spindle and manually push the valve plug to its closed position.
- Apply the control signal pressure required to bring the actuator spindle to mid-travel position.
- Place the actuator yoke over the valve spindle and locate onto the bonnet shoulder. Locate and tighten the valve mounting nut (20) to the recommended tightening torque (Table 1, page 14).
- Increase the air pressure until the upward travel stops (the diaphragm plate is against travel stoppers).
- Adjust the position of the valve spindle adaptor (17) so that the distance 'A', as shown in Figure 3, is equivalent to the desired travel indicated on the actuator travel indicator plate (18), then tighten the lock-nut (19) to the recommended torque, see Table 1, page 14.
- Release the control air signal to bring the actuator spindle against the valve spindle.
- Fit the anti-rotation plate (11). Fit the connector locking screws (12) and tighten to the recommended torque (Table 1, page 14).
- Check that the actuator stem and valve plug stem move freely in response to the air pressure change to the actuator.

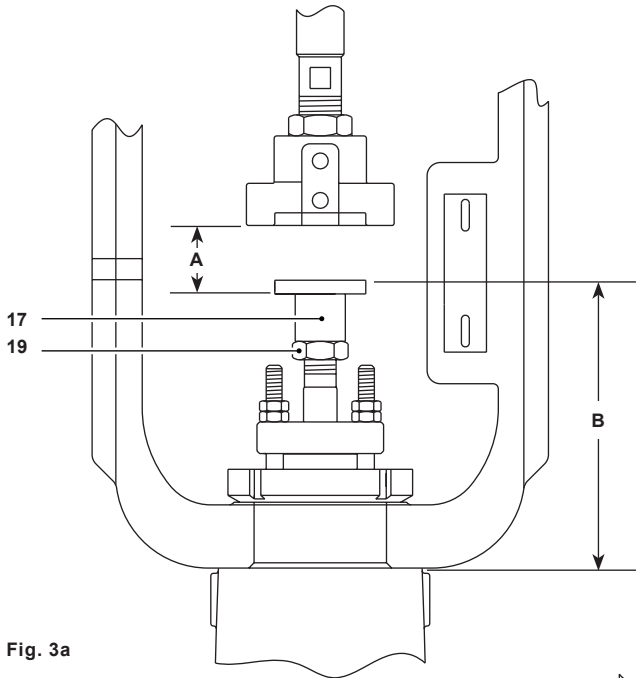

Valve size	B
1" to 4"	110 mm (4.32")
5" to 8"	130 mm (5.12")

Fig. 3a

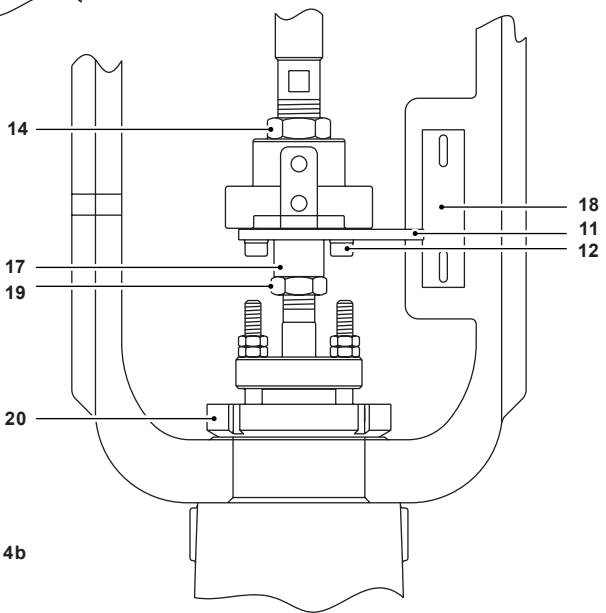
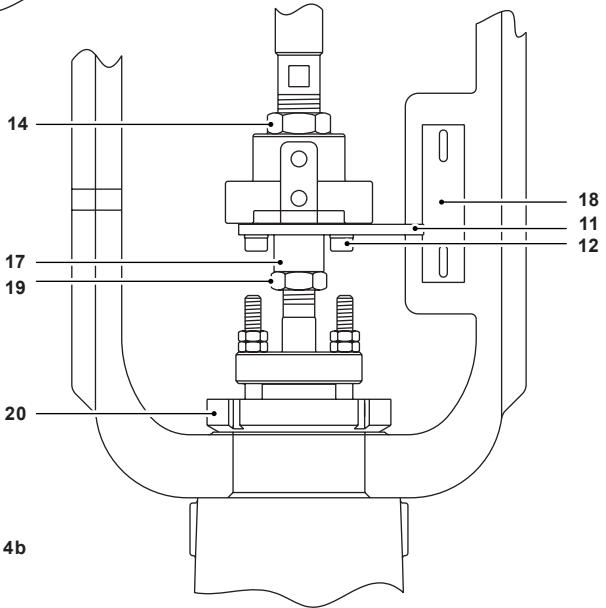
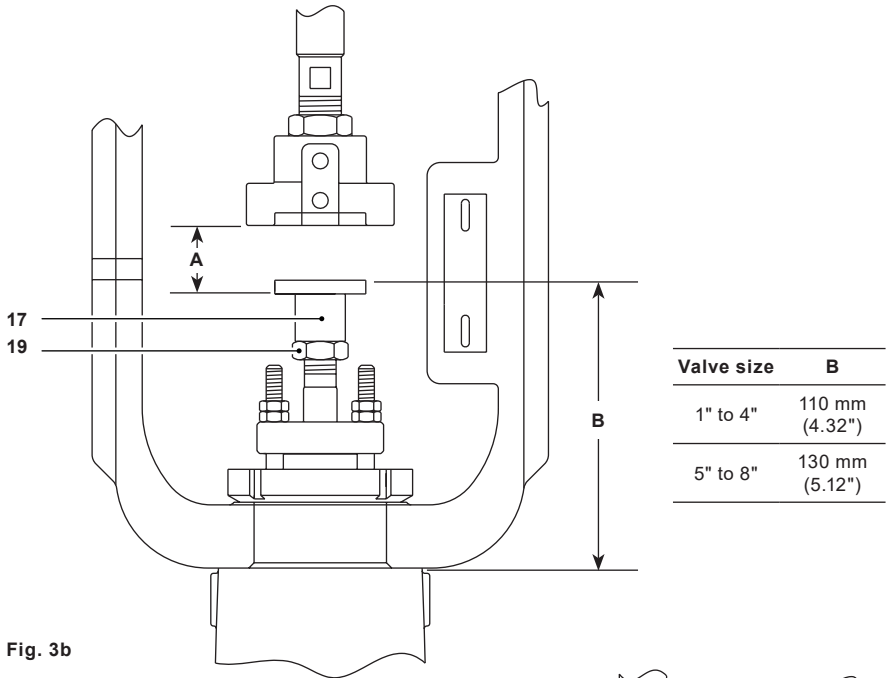

Fig. 4b

PN1000 and PN2000 Pneumatic Actuators

3.3 Fitting the PN2000 spring-to-retract series actuator to the valve (Refer to Figures 3a and 4b):

- Loosen and remove connector locking screws (12) and remove the anti-rotation plate (11).
- Fit the valve spindle adaptor (17) onto the valve spindle and manually push the valve plug to its closed position.
- Place actuator yoke over the valve spindle and locate onto bonnet shoulder. Locate and tighten the valve mounting nut (20) to the recommended tightening torque (Table 1, page 14).
- Adjust the position of the valve spindle adaptor (17) so that the distance 'B' is equivalent to the value shown in Figure 3, then tighten the lock-nut (19) (see Table 1, page 14).
- Increase the control air signal to bring the actuator spindle against the valve spindle.
- Fit the anti-rotation plate (11). Fit the connector locking screws (12) and tighten to the recommended torque (Table 1, page 14).
- Check that the actuator stem and valve plug stem move freely in response to the air pressure change to the actuator.



PN1000 and PN2000 Pneumatic Actuators

4. Commissioning

If the actuator/valve has been supplied with a positioner, reference should be made to the separate Installation and Maintenance Instructions for this product.

4.1 Adjusting the actuator lift off pressure (set point)

This is not applicable to the PN1700 and PN2700 series.

The actuator spring range and lift off pressure will be indicated on the name-plate. Should it be necessary to check or adjust the lift off pressure, for example if the actuator has been removed for maintenance, the procedure is described in Sections 4.1.1 and 4.1.2 below.

Note: Adjustment of the spring will only alter the pressure of the air control signal at which the valve commences to move off its seat (set point) and will not alter the spring pressure range required to move the valve through its full travel. For example:

- **Metric** 0.2 to 1.0 bar spring (range 0.8 bar) set to start lifting at 0.4 bar will require a 1.2 bar air pressure (0.4 + 0.8) to obtain the valve full travel.
- **Imperial** 2.9 to 14.5 psi spring (range 11.6 psi) set to start lifting at 5.8 psi will require a 17.4 psi air pressure (5.8 + 11.6) to obtain the valve full travel.

4.1.1 PN1000 spring-to-extend actuators

To adjust the set point refer to Figure 5 and proceed as follows:

- Ensure the control valve has been isolated and the actuator housing is pressure free.
- Increase the control signal pressure until the actuator starts to lift the actuator spindle.
- Check whether the signal pressure corresponds to the desired starting value.
- Completely release the air signal pressure.
- Adjust the spring set nut (**22**) by either tightening (clockwise) or loosening (anticlockwise) to increase/decrease the actual signal pressure starting value.
- Cycle the actuator to check that the valve just commences to move off its seat at the right spring range minimum pressure and is fully open at the spring range maximum pressure.
- For example: If the spring range is 0.4 to 1.2 bar (5.8 to 17.4 psi) the actuator should start to
- move at 0.4 bar (5.8 psi) and be fully open at 1.2 bar (17.4 psi).
- After the test, check the position of the travel indicator plate (**18**) against the position of the anti-rotation plate and adjust its position accordingly.

Important note:

To prevent damage to the valve seat, please ensure the plug does not turn while pressing on the seat during assembling or adjustment.

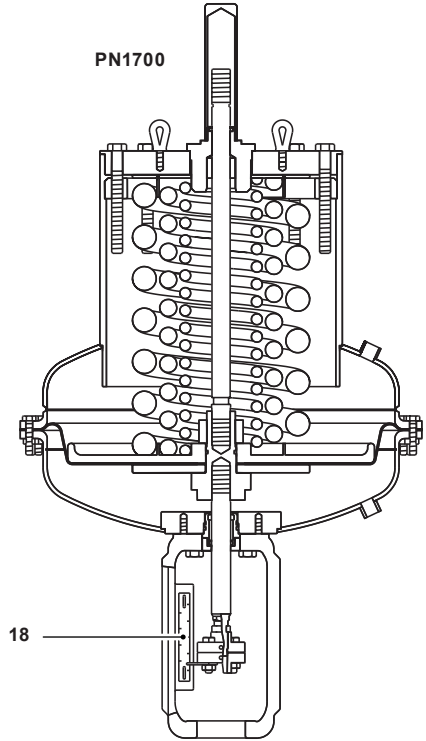
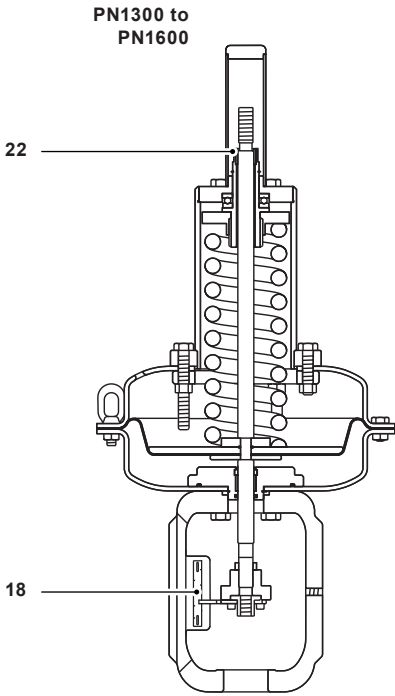

Note: There is no spring set nut (22) for the PN1700

Fig. 5 PN1000 series

4.1.2 PN2000 spring-to-retract actuators

To adjust the set point refer to Figure 6 and proceed as follows:

- Ensure the control valve has been isolated and the actuator housing is pressure free.
- Apply the control signal pressure required to complete the full travel of the actuator spindle. Check whether the signal pressure corresponds to the desired full travel value.
- Completely release the air signal pressure.
Adjust the spring set nut (22) by either tightening (clockwise) or loosening (anticlockwise) to increase/decrease the actual signal pressure starting value.
- Cycle the actuator to check that the valve just commences to move toward the seat at the right spring range minimum pressure and is fully closed at the spring range maximum pressure.
For example: If the spring range is 0.2 to 1.0 bar (2.9 to 14.5 psi) the actuator should start to move at 0.2 bar (2.9 psi) and be fully open at 1.0 bar (14.5 psi).
- After the test, check the position of the travel indicator (18) against the position of the anti-rotation plate and adjust its position accordingly.

Important note:

To prevent damage to the valve seat, please ensure the plug does not turn while pressing on the seat during assembling or adjustment.

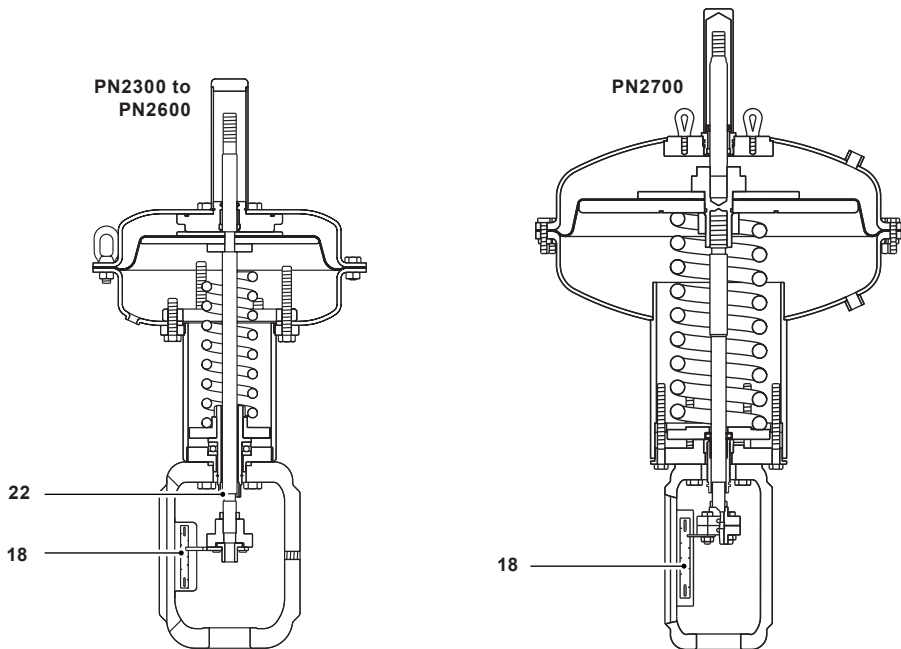

Note: There is no spring set nut (22) for the PN2700

Fig. 6 PN2000 series

5. Maintenance

For PN1000 see Sections 5.1, 5.2 and 5.3

For PN2000 see Sections 5.1, 5.2 and 5.4

5.1 General information

The PN1000 and PN2000 series pneumatic actuators are maintenance free. To ensure satisfactory operation it is strongly recommended that the air control signal is filtered and supplied free of oil and water. A Spirax Sarco MPC2 air coalescing filter regulator is the approved device. Naturally actuator parts are subject to normal wear and must be inspected and replaced when necessary.

This procedure describes how to disassemble and reassemble the actuator.

When maintenance is required, disassemble only those parts necessary to accomplish the job.

5.2 Removing the actuator from the valve

(Refer to Figure 7):

Note: In absence of an air signal to the PN1000 series actuators (spring-to-extend), the actuator spring exercises a load onto the valve spindle and, by reaction, onto the yoke mounting nut (20). Therefore, the spring load must be zeroed by following the procedure described in Section 5.2.1, prior to loosening the mounting nut (20). However, if the diaphragm is broken, the actuator can not be driven by the air signal, and the spring must be unloaded mechanically by using the procedure given in Section 5.2.2.

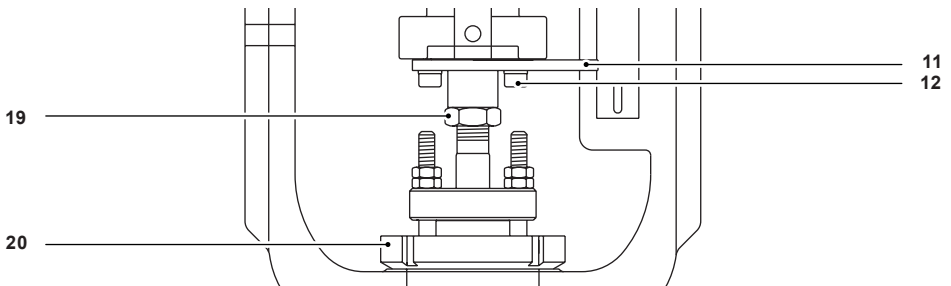

Fig. 7

5.2.1 Standard procedure to remove the actuator from the valve:

It is recommended that a length of flexible plastic tube, together with a push-in connector is available, so that the actuator can be disconnected from the pipework and be manually driven with the air supply.

- Isolate the control valve.
- Isolate the air supply to the actuator and disconnect the pipework from the actuator.
- Take out the compression fitting in the actuator and screw in the push-in connector. Connect your flexible tubing to the air supply and to the actuator.
- Drive the actuator to approximately the mid travel position with the air supply.
- Loosen and remove the connector screws (12) and remove the anti-rotation plate (11).
- Loosen and remove yoke mounting nut (20) and lift the actuator off the valve.
- Isolate the air supply, noting that the actuator will now extend (PN1000) or retract (PN2000).
- Remove the tubing.

5.2.2 Emergency procedure to remove the actuator from the valve:

- Isolate the control valve.
- Isolate the air supply to the actuator and disconnect the pipework from the actuator.
- **For the PN1300 to PN1600:**
Loosen and remove the diaphragm housing nuts and bolts (8).
Note: On certain spring ranges longer housing bolts are fitted. These should be removed after all other bolts are removed and should be loosened evenly to prevent distortion.
- **For the PN1700:**
Evenly loosen the cover screws (31).
Loosen and remove the connector screws (12) and remove the anti-rotation plate (11).
Loosen and remove the yoke mounting nut (20) and lift the actuator off the valve.

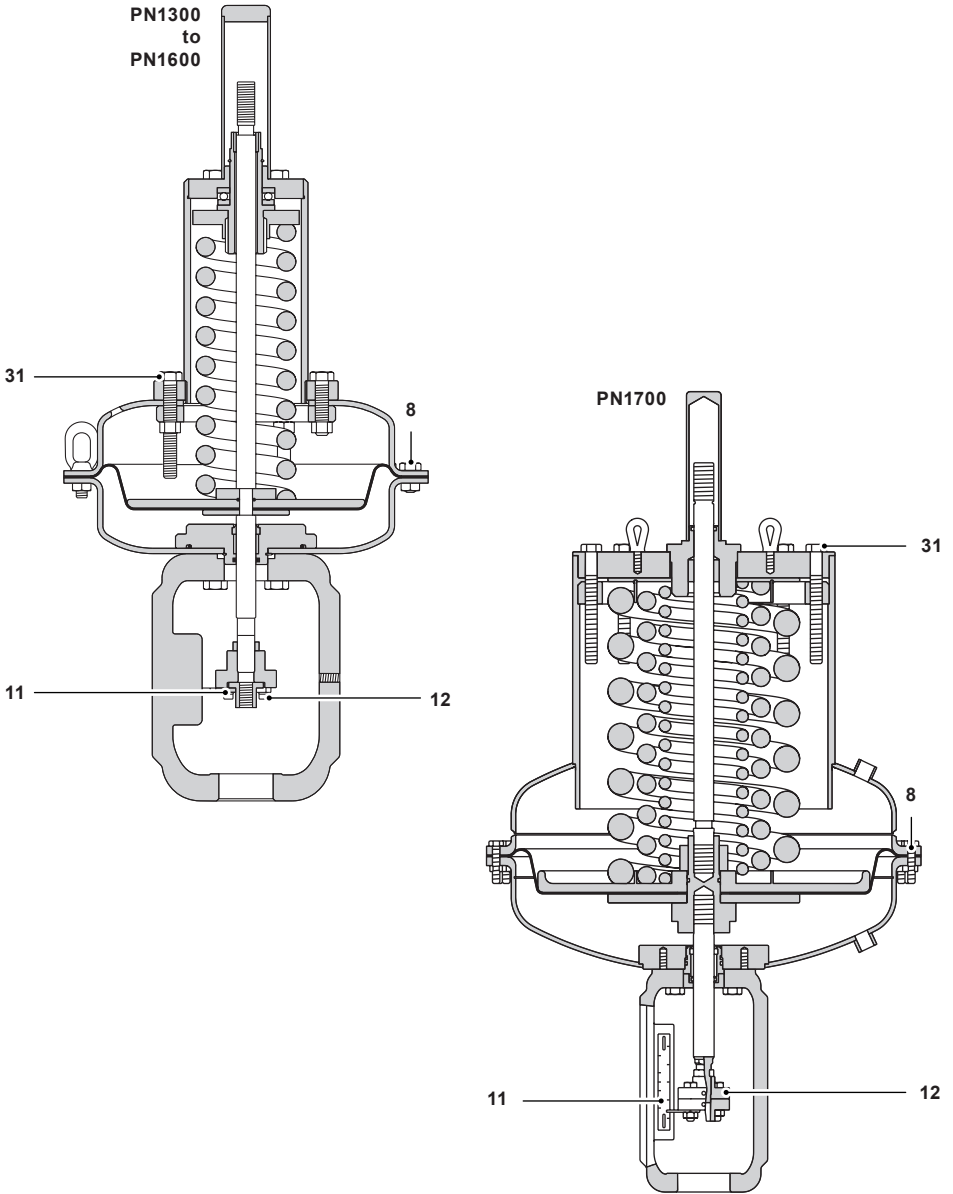

Fig. 8

PN1000 and PN2000 Pneumatic Actuators

5.3 PN1000 series (Refer to Figure 9):

5.3.1 Disassembly to replace the spring:

- Remove the actuator from the valve as described in Section 5.2.
- Completely loosen (anticlockwise) the spring set nut (22) to reduce the spring load to the minimum value.
- Loosen the connector lock-nut (14) and remove the connector (10) and lock-nut.
- Loosen and remove the diaphragm housing nuts and bolts (8) and remove the housing lid (1).
Note: On certain spring ranges longer housing bolts are fitted. These should be removed after all other bolts are removed and should be loosened evenly to prevent distortion.
- Remove the spring.

5.3.2 Disassembly to replace the diaphragm and the spindle seal:

- Remove the following parts: auxiliary spindle (23), spring guide (16), diaphragm plate (3), diaphragm (2), spacer (24), actuator spindle (9). Be careful in withdrawing the actuator spindle to avoid damaging the 'O' ring with the threads of the spindle.
- By using two spanners, loosen the auxiliary spindle from the actuator spindle to separate the parts of the assembly.
- Remove cap screws (25) and separate the lower housing from the yoke (7).
- Remove the snap ring (26) and remove the spindle guide and housing (5).
- Remove the 'V' ring (27) and 'O' ring (13) taking care not to damage the grooves.

Fig. 9a PN1300 to PN1600 series

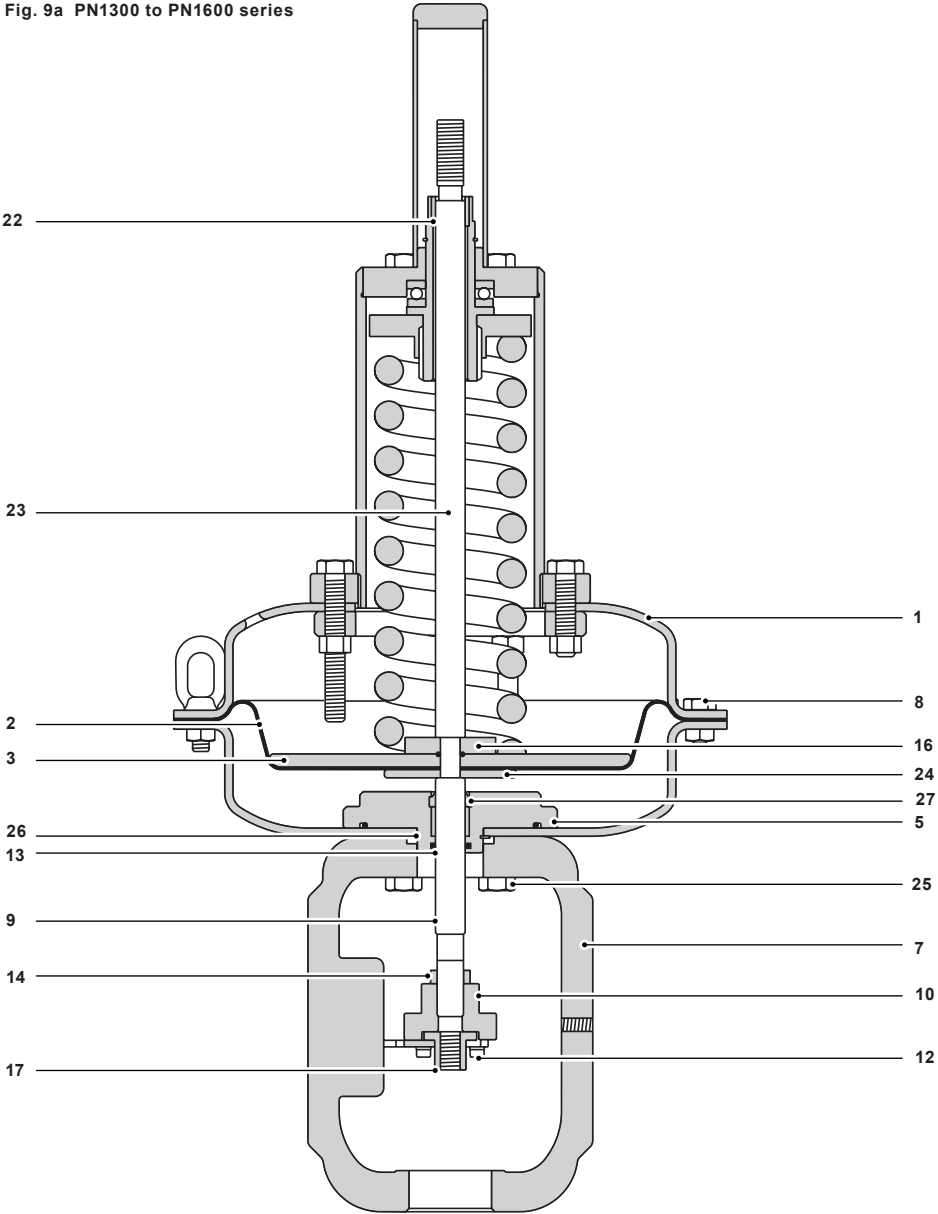

5.3.3 Assembly:

- Smear new 'V' ring and 'O' ring with silicon grease and place in the seal bushing.
- Place a new gasket (28) in the spindle guide (5), position the guide in the lower housing, align the holes and secure with snap ring (26).
- Assemble the yoke to the lower housing with the cap screws (25).
- Assemble the actuator spindle, spacer, diaphragm, diaphragm plate, spacer and auxiliary spindle. Using two spanners, whilst holding the actuator spindle, tighten the auxiliary spindle. Refer to Table 1 for recommended tightening torques.
- Refit the actuator spindle taking care not to damage the 'V' ring and 'O' ring or spindle surface.
- Refit the spring.
- Refit the diaphragm housing nuts and bolts (8). **Refer to Table 1 below for the recommended tightening torques.**

Note 1: On certain spring ranges longer housing bolts are fitted (8). Where supplied, these should be positioned evenly apart and tightened evenly prior to fitting the remaining bolts.

Note 2: To avoid distortion of the diaphragm do not fully tighten housing bolts until all bolts have been fitted. Final tightening should then be carried out evenly. **Refer to Table 1 below for the recommended tightening torques.**

**Table 1 PN1300/PN2300 to PN1600/ PN2600
Recommended tightening torques**

Item No.	Part		N m	lbf ft
8	Housing securing nuts and bolts		15 ± 2	11 ± 1.5
9	Actuator spindle/auxiliary spindle		40 - 50	29 - 37
12	Connector locking screws		25 - 30	18 - 22
14	Actuator spindle lock-nut		40 - 50	29 - 37
19	Valve spindle lock-nut (see Figure 7)		40 - 50	29 - 37
20	Valve mounting nut (see Figure 7)	M50	70 - 80	52 - 59
		M70	140 - 150	104 - 111
25	Yoke to housing cap screws		40 - 50	29 - 37

Fig. 9b PN1300 to PN1600 series

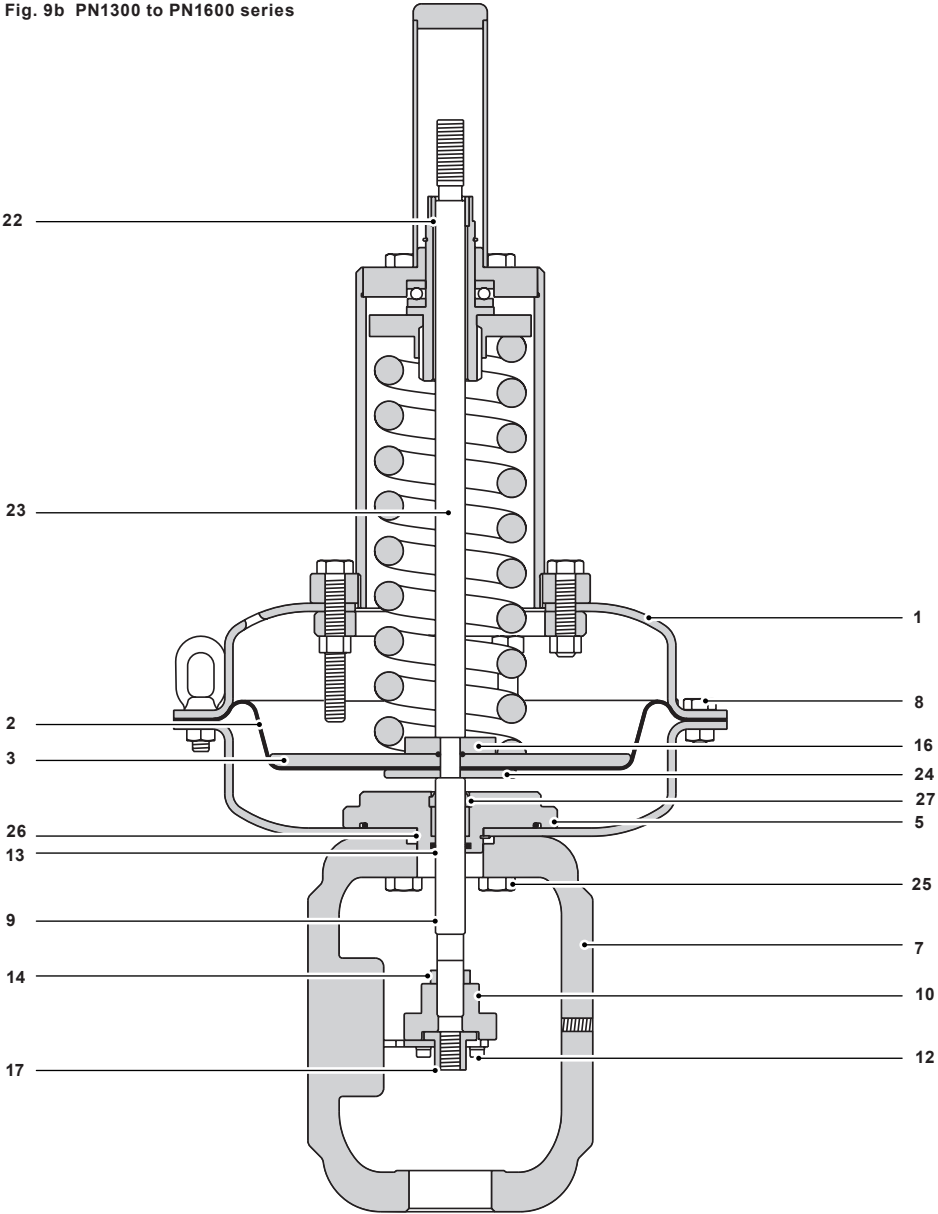

PN1000 and PN2000 Pneumatic Actuators

5.4 PN2300 to PN2600 series (Refer to Figure 10):

5.4.1 Disassembly to replace the spring:

- Remove the actuator from the valve as described in Section 5.2.
- Completely loosen (anticlockwise) the spring set nut (22) to reduce the spring load to the minimum value.
- Loosen the connector lock-nut (14) and remove the connector (10) and lock-nut.
- Loosen and remove the diaphragm housing nuts and bolts (8) and remove the housing lid (1).
Note: On certain spring ranges longer housing bolts are fitted. These should be removed after all other bolts are removed and should be loosened evenly to prevent distortion.
- Remove the spring.

5.4.2 Disassembly to replace the diaphragm and the spindle seal:

- Remove the assembly constituted by the following parts: auxiliary spindle (9), spindle guide (5), diaphragm plate (3), diaphragm (2), spacer (24), actuator spindle (10). Be careful in withdrawing the actuator spindle to avoid damaging the 'O' ring with the threads of the spindle.
- By using two spanners, loosen the auxiliary spindle from the actuator spindle to separate the parts of the assembly.
- Remove cap screws (25), the snap ring (26) and remove the seal bushing (27).
- Remove the 'V' ring (20) and 'O' ring (21) taking care not to damage the grooves.

Fig. 10a PN2000 series

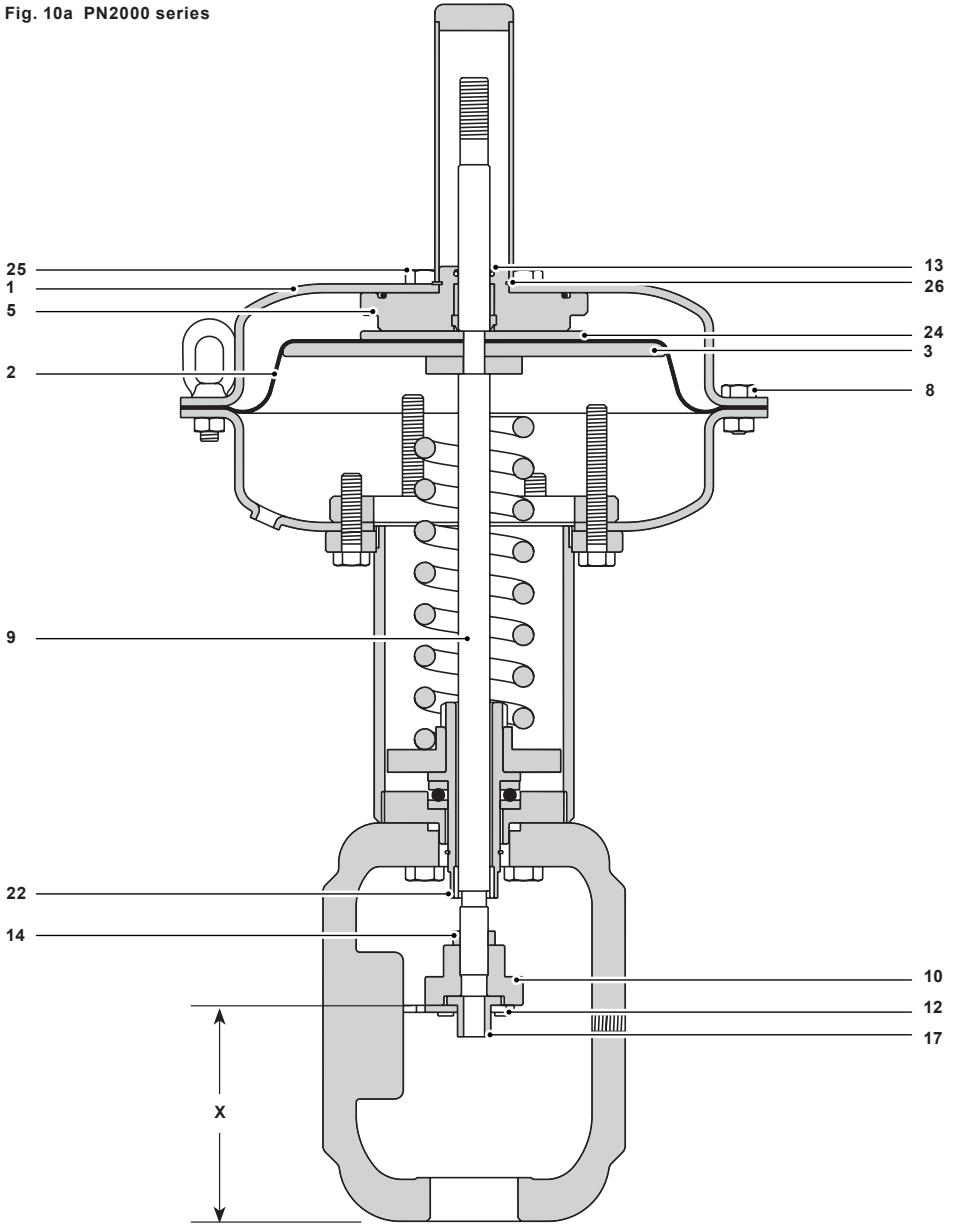

PN1000 and PN2000 Pneumatic Actuators

5.4.3 Assembly:

- Smear new 'V' ring and 'O' ring with silicon grease and place in the seal bushing.
- Place a new gasket 'O' ring (13) in the seal bushing groove, position the bushing in the lower housing, align the holes and secure with snap ring (26). Refit the cap screws (25).
- Assemble the actuator spindle, spacer, diaphragm, diaphragm plate, spacer and auxiliary spindle. Using two spanners, whilst holding the actuator spindle, tighten the auxiliary spindle. Refer to Table 1 on page 14, for recommended tightening torques.
- Refit the actuator spindle taking care not to damage the 'V' ring and 'O' ring or spindle surface.
- Refit the spring.
- Refit the top housing and securing nuts and bolts (8). Refer to Table 1, for the recommended tightening torques.

Note 1: On certain spring ranges longer housing bolts are fitted (8). Where supplied, these should be positioned evenly apart and tightened evenly prior to fitting the remaining bolts.

Note 2: To avoid distortion of the diaphragm do not fully tighten housing bolts until all bolts have been fitted. Final tightening should then be carried out evenly. Refer to Table 1, on for the recommended tightening torques.

- Adjust the position of the adaptor (10), so that distance from the bottom of the yoke is equivalent to the dimension 'X', and tighten the lock-nut (14).

Note 3: The travel is marked on the actuator label.

Table 2 Dimension 'X' approximate in mm (inches) (See Figure 10)

Actuator type	Travel				
	20 mm (¾")	30 mm (16")	38 mm (1½")	50 mm (2")	75 mm (3")
PN1300 to PN1600	130 (5.1)	140 (5.5)	148 (5.8)	160 (6.3)	160 (6.3)
PN2300	133 (5.2)	143 (5.6)	151 (5.9)	- -	- -
PN2400	138 (5.4)	148 (5.8)	156 (6.1)	168 (6.6)	- -
PN2500 and PN2600	145 (5.7)	155 (6.1)	163 (6.4)	175 (6.9)	200 (7.9)
PN2700	- -	- -	163 (6.4)	175 (6.9)	200 (7.9)

Fig. 10b PN2000 series

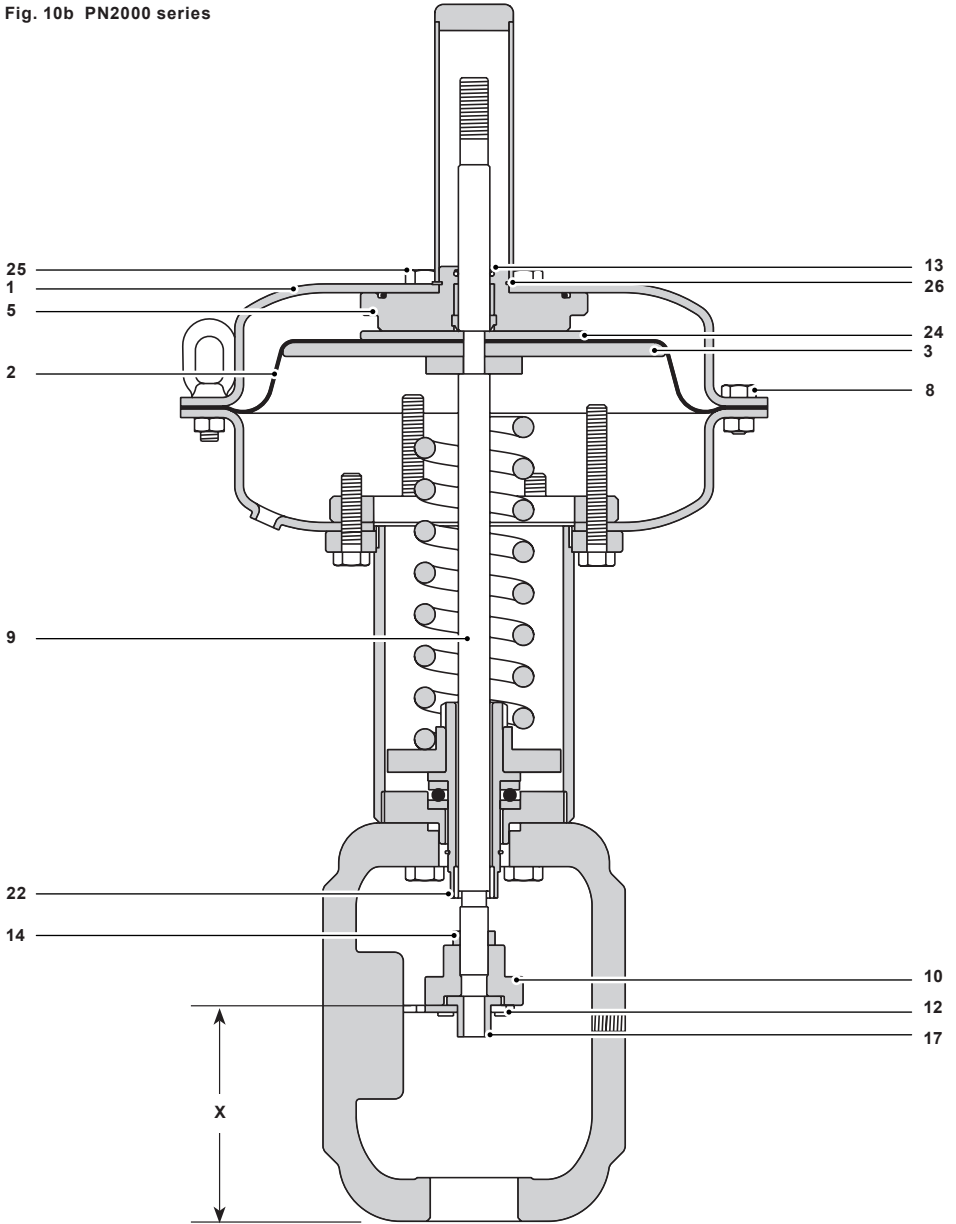

PN1000 and PN2000 Pneumatic Actuators

5.5 PN1700 series (Refer to Figure 11):

5.5.1 Disassembly to replace the spring:

- Remove the actuator from the valve as described in Section 5.2.
- Unscrew the spring housing cover screws (31).
Note 1: The spring housing cover (32) is spring loaded. Therefore the cover screws (31) must be loosened evenly.
- Remove the cover (32), remove the spring holder (33) and withdraw the spring(s) (4).

5.5.2 Disassembly to replace the diaphragm and the spindle seal:

Ensure that all steps in Section 5.5.1 have been completed before proceeding with the following:

- Loosen and remove the diaphragm housing nuts and bolts (8) and remove the housing lid (1).
- Remove the following parts: auxiliary spindle (23), diaphragm plate (3), diaphragm (2), spacer (24), actuator spindle (9). Be careful in withdrawing the actuator spindle to avoid damaging the 'O' ring with the threads of the spindle.
- By holding the spacer (24), loosen the lock-nut (16) to separate the parts of the assembly.
- Remove cap screws (25) and separate the lower housing from the yoke (7).
- Remove the spindle guide and housing (5).
- Remove the 'V' ring (27) and 'O' ring (13) taking care not to damage the grooves.

Fig. 11a PN1700 series

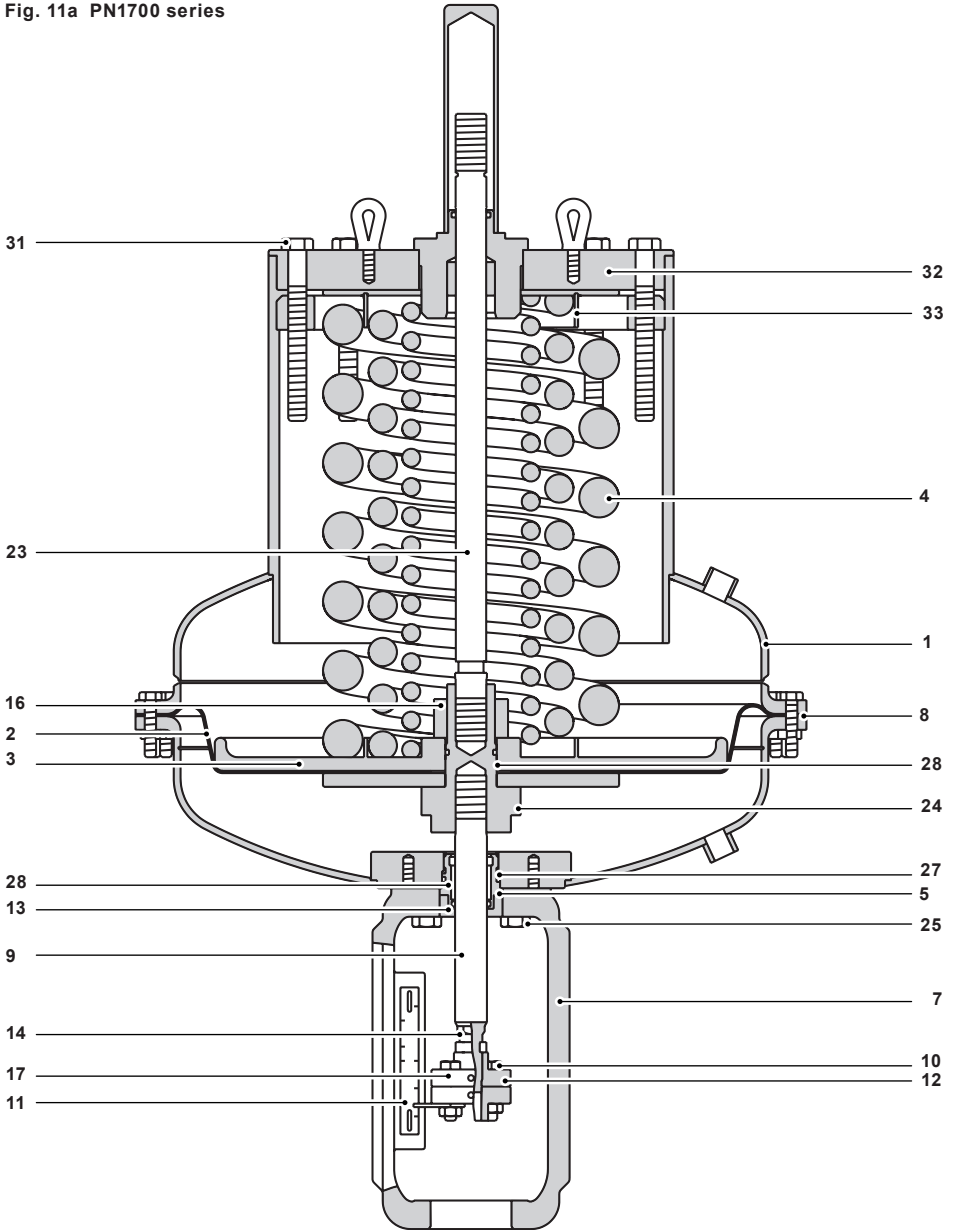

PN1000 and PN2000 Pneumatic Actuators

5.5.3 Assembly:

- Smear new 'V' ring and 'O' ring with silicon grease and place in the seal bushing.
- Place a new gasket (28) in the spindle guide (5), position the guide in the lower housing.
- Assemble the yoke to the lower housing with the cap screws (25).
- Assemble the actuator spindle (9), spacer (24), diaphragm (2), diaphragm plate (3) and auxiliary spindle (23). Whilst holding the spacer (24), tighten the lock-nut (16). Refer to Table 1, page 14, for recommended tightening torques.
- Refit the actuator spindle taking care not to damage the 'V' ring and 'O' ring or spindle surface.
- Refit the diaphragm housing nuts and bolts (8).

Note 1: To avoid distortion of the diaphragm do not fully tighten housing bolts until all bolts have been fitted. Final tightening should then be carried out evenly. Refer to Table 3 below for the recommended tightening torques.

- Refit the spring(s) (4).
- Refit the spring holder (33). Refit the spring housing cover (32).
- Refit the spring housing cover screws (31) (see Table 3 below).

Note 2: The spring housing cover (32) is spring loaded. Therefore the cover screws (31) must be tightened evenly.

Table 3 PN1700 and PN2700 Recommended tightening torques

Item No.	Part	N m	lbf ft
8	Housing securing nuts and bolts	40 ± 2	29 ± 1.5
12	Connector locking screws	25 - 30	18 - 22
14	Actuator spindle lock-nut	40 - 50	29 - 37
19	Valve spindle lock-nut (see Figure 7)	40 - 50	29 - 37
16	Diaphragm plate assembly lock-nut	40 - 50	29 - 37
20	Valve mounting nut (see Figure 7)	M50	70 - 80
		M70	140 - 150
25	Yoke to housing cap screws	40 - 50	29 - 37

Fig. 11b PN1700 series

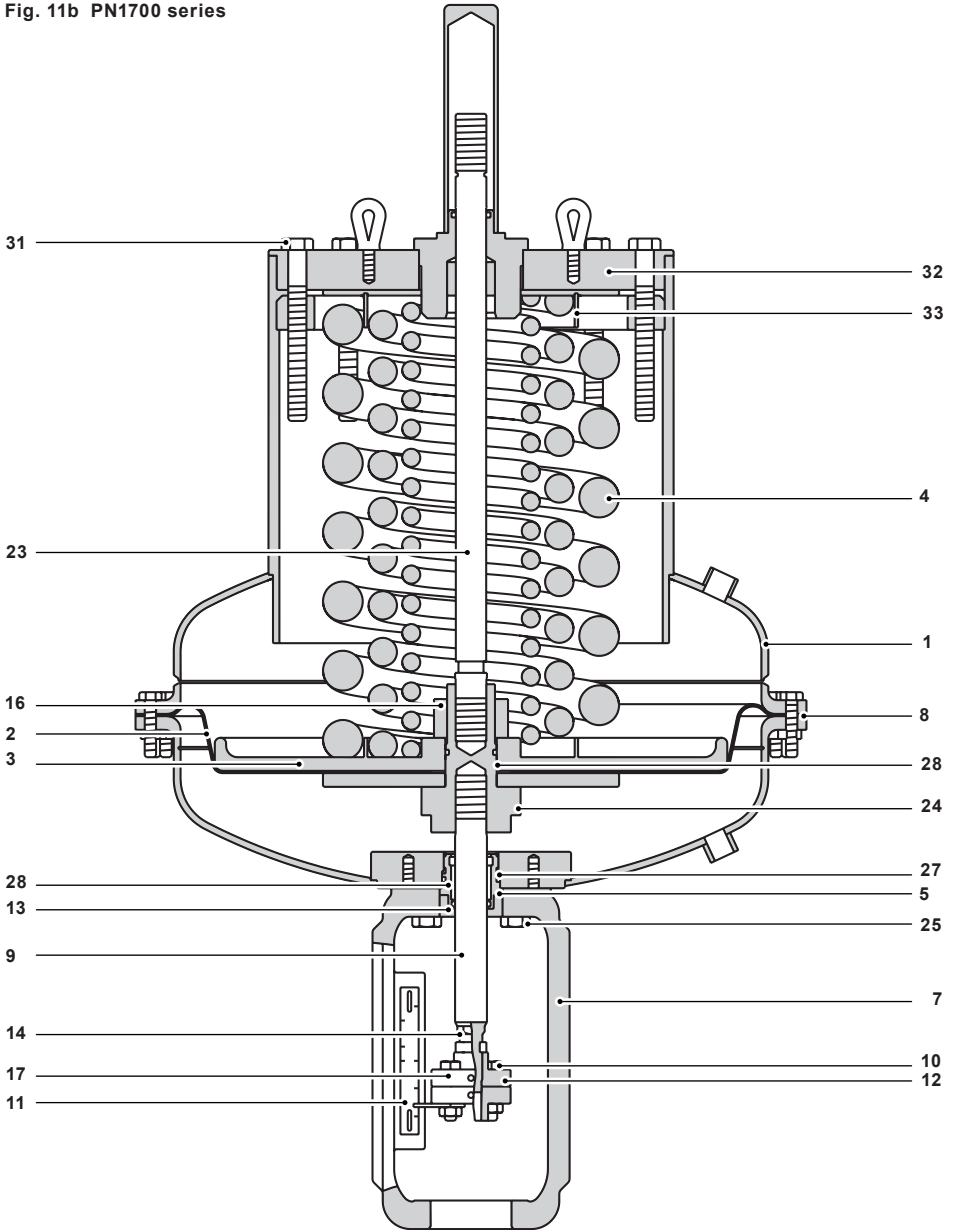

PN1000 and PN2000 Pneumatic Actuators

5.6 PN2700 series (Refer to Figure 12):

5.6.1 Disassembly to replace the spring:

- Remove the actuator from the valve as described in Section 5.2.
- Unscrew the spring housing cover screws (31).
Note 1: The spring housing cover (32) is spring loaded. Therefore the cover screws (31) must be loosened evenly.
- Remove the cover (32), remove the spring holder (33) and withdraw the spring(s) (4).

5.6.2 Disassembly to replace the diaphragm and the spindle seal:

Ensure that all steps in Section 5.6.1 have been completed before proceeding with the following:

- Loosen and remove the diaphragm housing nuts and bolts (8) and remove the housing lid (1).
- Remove the following parts: auxiliary spindle (23), diaphragm plate (3), diaphragm (2), spacer (24), actuator spindle (9). Be careful in withdrawing the actuator spindle to avoid damaging the 'O' ring with the threads of the spindle.
- By holding the spacer (24), loosen the lock-nut (16) to separate the parts of the assembly.
- Remove the spindle guide and housing (5).
- Remove the 'V' ring (27) and 'O' ring (13) taking care not to damage the grooves.

5.6.3 Assembly:

- Smear new 'V' ring and 'O' ring with silicon grease and place in the seal bushing.
- Place a new gasket (28) in the spindle guide (5), position the guide in the upper housing.
- Assemble the actuator spindle (9), spacer (24), diaphragm (2), diaphragm plate (3) and auxiliary spindle (23). Whilst holding the spacer (24), tighten the lock-nut (16). Refer to Table 1, page 14, for recommended tightening torques.
- Refit the actuator spindle taking care not to damage the 'V' ring and 'O' ring or spindle surface.
- Refit the diaphragm housing nuts and bolts (8).
Note 1: To avoid distortion of the diaphragm do not fully tighten housing bolts until all bolts have been fitted. Final tightening should then be carried out evenly. Refer to Table 3, page 18, for the recommended tightening torques.
- Refit the spring(s).
- Refit the spring holder (33). Refit the spring housing cover (32).
- Refit the spring housing cover screws (31).
Note 2: The spring housing cover (32) is spring loaded. Therefore the cover screws (31) must be tightened evenly.
- Adjust the position of the adaptor (10), so that distance from the bottom of the yoke is equivalent to the dimension 'X' (see Table 3, page 18), and tighten the lock-nut (14).
Note 3: The travel is marked on the actuator label.

Fig. 12 PN2700 series

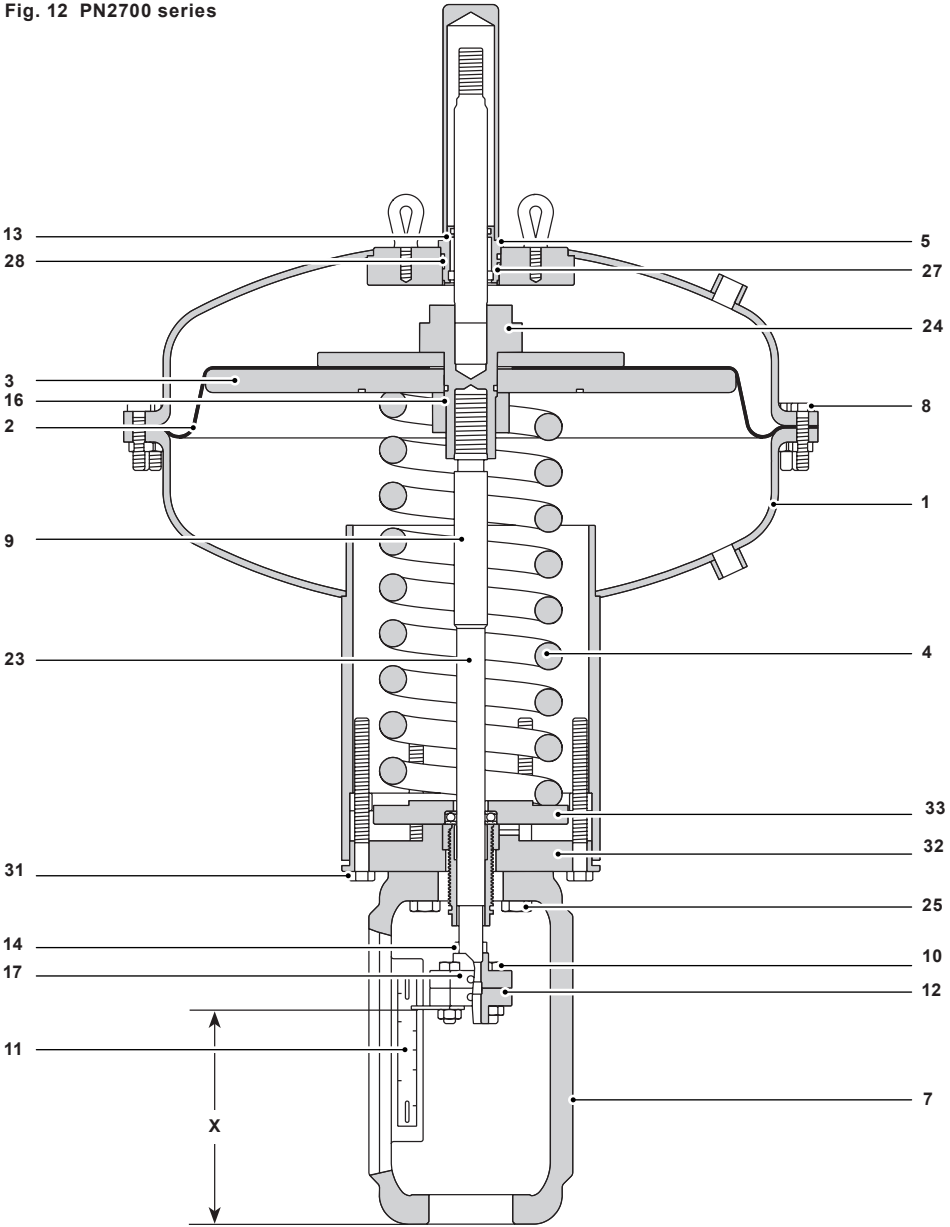

6. Spare parts

Spare parts PN1000 series

The spare parts available are detailed below. No other parts are supplied as spares.

Available spares

Stem seal kit	Spindle 'O' ring and 'V' ring, diaphragm plate 'O' ring and spring guide gasket	B, C, D, H
Diaphragm kit	Diaphragm	A
Spring kit	Replacement spring	E

How to order spares

Always order spares by using the description given in the column headed 'Available spares' and state the actuator type.

Example for PN1000: 1 Stem seal kit for a PN1520A2 pneumatic actuator.

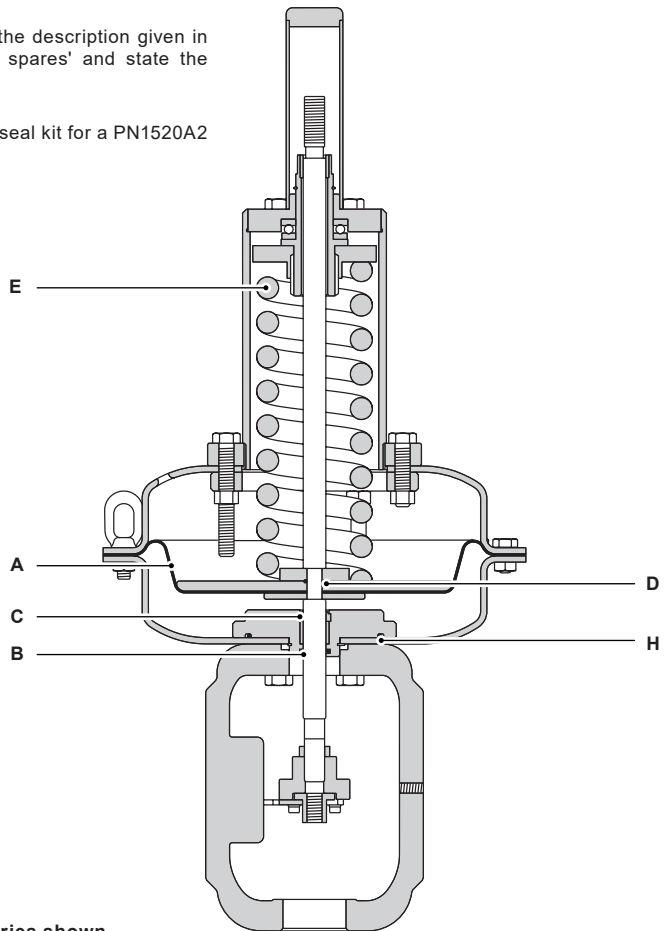

Fig. 13 PN1300 to PN1600 series shown

Spare parts PN2000 series

The spare parts available are detailed below. No other parts are supplied as spares.

Available spares

Stem seal kit	Spindle 'O' ring and 'V' ring, diaphragm plate 'O' ring, and spring guide gasket	B, C, D, H
Diaphragm kit	Diaphragm	A
Spring kit	Replacement spring	E

How to order spares

Always order spares by using the description given in the column headed 'Available spares' and state the actuator type.

Example for PN2000: 1 Stem seal kit for a PN2520A2 pneumatic actuator.

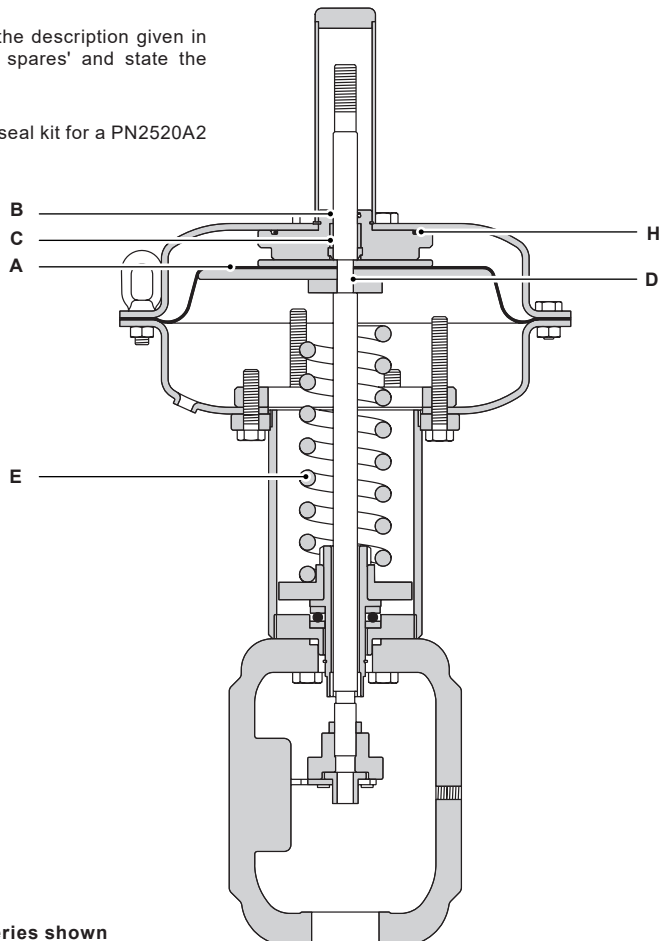

Fig. 14 PN2300 to PN2600 series shown

