

PA20
Preamplifier
Installation and Maintenance Instructions

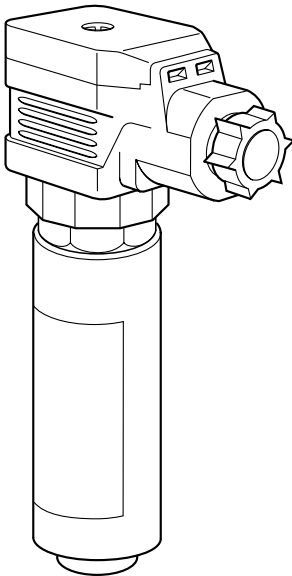

- 1. Safety information*
- 2. General product information*
- 3. Installation*
- 4. Wiring*
- 5. Voltage check*
- 6. Maintenance*



1. Safety information

Safe operation of the product depends on it being properly installed, commissioned and maintained by a qualified person (see Section 1.11) in compliance with the operating instructions.

It is essential to comply with general installation and safety instructions for pipeline and plant construction, as well as to make proper use of tools and safety equipment.

The product is designed and constructed to withstand the forces encountered during normal use. Use of the product for any other purpose, or failure to install the product in accordance with these Installation and Maintenance Instructions, could cause damage to the product, will invalidate the CE marking, and may cause injury or fatality to personnel.

Additional Safety Notes:

Level control and level limiting / alarm products in steam boilers

Products/systems must be selected, installed, operated, and tested in accordance with:

- Local or National standards and regulations.
- Guidance Notes, (Health and Safety Executive BG01 and INDG436 in the UK).
- The requirements of Approvals Authorities.
- Boiler inspection bodies.
- Boiler manufacturer's specifications.

Two independent low water limiting / alarm systems must be installed on steam boilers. Level probes must be installed in separate protection tubes / chambers, with sufficient clearance between the tips, and earth.

Each probe must be connected to an independent controller. The alarm relays must isolate the boiler heat supply at low alarm status.

A high water alarm may be part of the water level control, or a separate system. An independent high water alarm system must be fitted if it is considered a safety requirement. In this case, the relays must simultaneously isolate the feedwater supply and the boiler heat supply at high alarm status. All boiler water limiters / alarms require regular functional testing.

A suitable water treatment regime must be used to ensure continuous safe and correct operation of the control and limiter / alarm systems. Consult the above authorities and a competent water treatment company.

Warning

Isolate the mains supply before unplugging the controller since hazardous voltages will be exposed on the controller base. This product complies with the requirements of Electromagnetic Compatibility Directive 89/336/EEC amended by 92/31/EEC and 93/68/EEC by meeting the standards of:

- EN 61326 : 1997 A1 + A2 Emissions Class B equipment Table 4.
- EN 61326 : 1997 A1 + A2 Immunity for Industrial Locations Annex A.

The following conditions should be avoided as they may create interference above the limits specified in EN 61326 (Immunity) if:

- The product or its wiring is located near a radio transmitter.
- Excessive electrical noise occurs on the mains supply. Power line protectors (ac) should be installed if mains supply noise is likely. Protectors can combine filtering, suppression, surge and spike arrestors.
- Cellular telephones and mobile radios may cause interference if used within approximately 1 metre (39") of the product or its wiring. The actual separation distance necessary will vary according to the surroundings of the installation and the power of the transmitter.

If this product is not used in the manner specified by this IMI, then the protection provided may be impaired.

1.1 Intended use

- Check that the product is suitable for use with the intended fluid.
- Check material suitability, pressure and temperature and their maximum and minimum values. If the maximum operating limits of the product are lower than those of the system in which it is being fitted, or if malfunction of the product could result in a dangerous overpressure or overtemperature occurrence, ensure a safety device is included in the system to prevent such over-limit situations.
- Determine the correct installation situation and direction of fluid flow.
- Spirax Sarco products are not intended to withstand external stresses that may be induced by any system to which they are fitted. It is the responsibility of the installer to consider these stresses and take adequate precautions to minimise them.
- Remove protection covers from all connections before installation.

Safe operation of these products can only be guaranteed if they are properly installed, commissioned, used and maintained by qualified personnel (see Section 11 on this document) in compliance with the operating instructions. General installation and safety instructions for pipeline and plant construction, as well as the proper use of tools and safety equipment must also be complied with.

1.2 Access

Ensure safe access and if necessary a safe working platform (suitably guarded) before attempting to work on the product. Arrange suitable lifting gear if required.

1.3 Lighting

Ensure adequate lighting, particularly where detailed or intricate work is required.

1.4 Hazardous liquids or gases in the pipeline

Consider what is in the pipeline or what may have been in the pipeline at some previous time. Consider: flammable materials, substances hazardous to health, extremes of temperature.

1.5 Hazardous environment around the product

Consider: explosion risk areas, lack of oxygen (e.g. tanks, pits), dangerous gases, extremes of temperature, hot surfaces, fire hazard (e.g. during welding), excessive noise, moving machinery.

1.6 The system

Consider the effect on the complete system of the work proposed. Will any proposed action (e.g. closing isolation valves, electrical isolation) put any other part of the system or any personnel at risk?

Dangers might include isolation of vents or protective devices or the rendering ineffective of controls or alarms. Ensure isolation valves are turned on and off in a gradual way to avoid system shocks.

1.7 Pressure systems

Ensure that any pressure is isolated and safely vented to atmospheric pressure. Consider double isolation (double block and bleed) and the locking or labelling of closed valves. Do not assume that the system has depressurised even when the pressure gauge indicates zero.

1.8 Temperature

Allow time for temperature to normalise after isolation to avoid danger of burns.

1.9 Tools and consumables

Before starting work ensure that you have suitable tools and/or consumables available. Use only genuine Spirax Sarco replacement parts.

1.10 Protective clothing

Consider whether you and/or others in the vicinity require any protective clothing to protect against the hazards of, for example, chemicals, high/low temperature, radiation, noise, falling objects, and dangers to eyes and face.

1.11 Permits to work

All work must be carried out or be supervised by a suitably competent person. Installation and operating personnel should be trained in the correct use of the product according to the Installation and Maintenance Instructions.

Where a formal 'permit to work' system is in force it must be complied with. Where there is no such system, it is recommended that a responsible person should know what work is going on and, where necessary, arrange to have an assistant whose primary responsibility is safety.

Post 'warning notices' if necessary.

1.12 Handling

Manual handling of large and/or heavy products may present a risk of injury. Lifting, pushing, pulling, carrying or supporting a load by bodily force can cause injury particularly to the back. You are advised to assess the risks taking into account the task, the individual, the load and the working environment and use the appropriate handling method depending on the circumstances of the work being done.

1.13 Residual hazards

In normal use the external surface of the product may be very hot.

Many products are not self-draining. Take due care when dismantling or removing the product from an installation.

1.14 Freezing

Provision must be made to protect products which are not self-draining against frost damage in environments where they may be exposed to temperatures below freezing point.

1.15 Disposal

Unless otherwise stated in the Installation and Maintenance Instructions, this product is recyclable and no ecological hazard is anticipated with its disposal providing due care is taken.

1.16 Returning products

Customers and stockists are reminded that under EC Health, Safety and Environment Law, when returning products to Spirax Sarco they must provide information on any hazards and the precautions to be taken due to contamination residues or mechanical damage which may present a health, safety or environmental risk. This information must be provided in writing including Health and Safety data sheets relating to any substances identified as hazardous or potentially hazardous.

— 2. General product information —

The PA20 preamplifier is used with a Spirax Sarco capacitance probe to amplify a measured capacitance and convert it to a voltage output proportional to a liquid level.

It consists of a tubular austenitic stainless steel body which screws onto the top of the probe, and has either a DIN 43650 connector with a Pg 11 cable gland (see Figure 1), or, for the UL listed version, a ½" NPT conduit thread adaptor with four flying leads (see Figure 2). Maximum ambient temperature is 70°C (158°F) and minimum ambient temperature is 0°C (32°F). The preamplifier is intended for use in a Pollution Degree 3 environment.

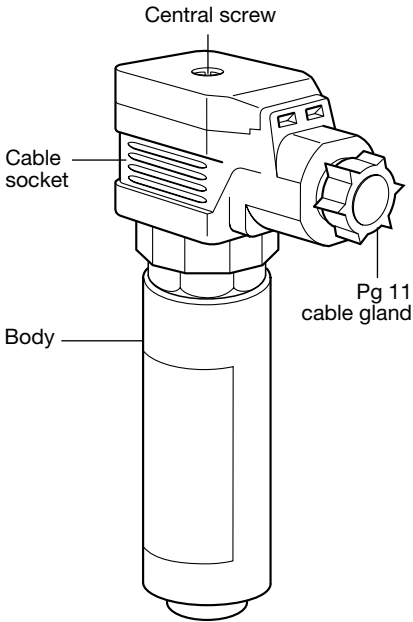

Fig. 1 Standard version

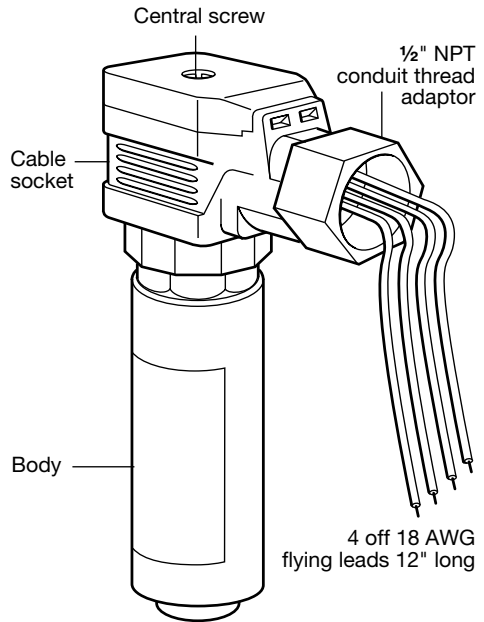

Fig. 2 UL Listed version

3. Installation

CAUTION: Do not install the PA20 outdoors without additional weather protection.

The preamplifier may be fitted to the capacitance probe before or after installation in the boiler or tank. Always allow the PA20 to stabilise at its normal operating temperature for at least 15 minutes before commissioning the controller/transmitter.

- Fit the 'O' ring supplied with the unit to the base of the male thread on the capacitance probe.
Note: Both the probe and the PA20 are provided with an 'O' ring - fit only one of these.
- Fit the preamplifier to the probe and hand tighten only.

CAUTION: Over-tightening by hand or use of a wrench will cause damage to the 'O' ring and may damage the preamplifier.

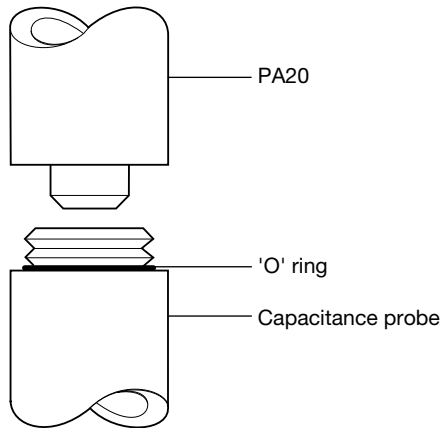

Fig. 3

4. Wiring

4.1 General information

Cabling should be installed in accordance with BS 6739 - Instrumentation in Process Control Systems: Installation design and practice or local equivalent. For the US and Canadian installation, the preamplifier must be wired in accordance with local and National Electrical Codes (NEC) or Canadian Electrical Code (CEC).

The PA20 needs a supply of 15-35 Vdc at 10 mA maximum. The UL product must be powered by either a NEC Class 2 power source, NEC Limited Power source (LPS) or a UL / IEC 61010-1 limited energy circuit.

The PA20 is compatible with all Spirax Sarco voltage input controllers/transmitters.

Wiring should be carried out in 3-core, 1 mm² (18-16 AWG), high temperature screened cable, with a maximum length of 100 m (328 ft). Pirelli FP 200 or Delta Crompton Firetuf OHLS are two suitable types for the standard PA20. Ensure that sufficient cable length is provided to allow removal of the preamplifier, and to ensure that no strain is placed on the unit or cable socket.

CAUTION:

Do not install signal cables near high voltage cables or switchgear.

Probe cabling must not use the same conduit/wiring trays as power cables.

Suitable anti-static precautions must be observed during installation and maintenance.

4.2 Screen connection

An earth current loop is created if a wire or screen is connected between two earth points, which are at different potential (voltage). If the instructions are followed correctly, then the preamplifier and controller screen will only be connected to earth at one end (See Figure 4).

Note: The PA20 earth terminal is a functional earth rather than a protective earth.

A protective earth provides protection from electric shock under a single fault condition. This product does not require a protective earth.

A functional earth is used in order for the product to operate. In this application, the earth (tank/boiler shell) is used as the common of the probe/preamplifier. It also provides a sink/drain for any electrical interference.

Ensure that the screen is connected to the earth terminal of the PA20 and to the common terminal of the controller.

Ensure the common terminal of the controller is not internally earthed. (All Spirax Sarco boiler controls are internally isolated from earth).

The common terminal of the controller must only be earthed via the PA20.

CAUTION:

Do not connect the common terminal to an earth local to the controller. To do so may induce an earth current loop, which may reduce the performance or damage the product. Ensure resistance from probe body to pipework/boiler shell is less than 1 Ω.

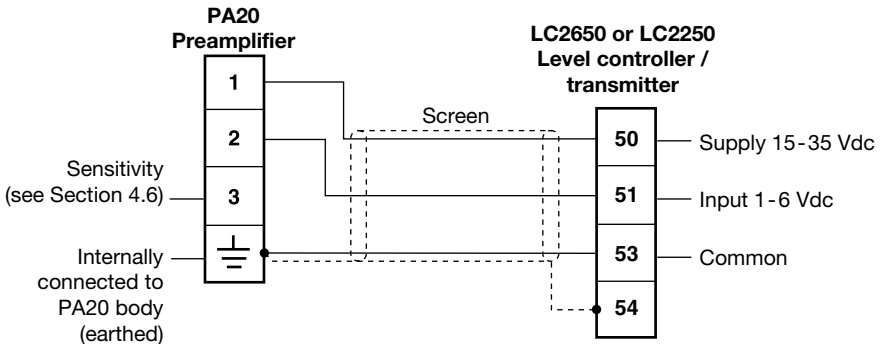

CAUTION:

Do not connect terminal 55 directly to earth. It must only be earthed via the probe wiring.

Fig. 4

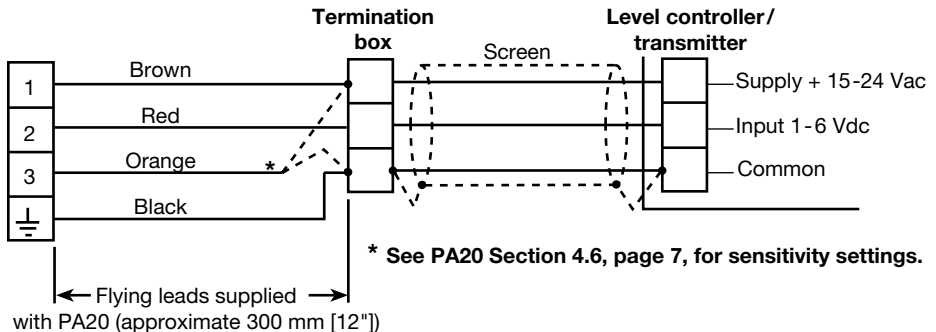

Fig. 5

4.3 Cable socket

To unplug the cable socket, remove the central screw (see Figures 1 and 2).

Note: To provide environmental protection the PA20 is supplied with a square flat gasket between the cable socket and the preamplifier connector. To maintain environmental integrity, ensure that the gasket is always present when reconnecting the cable socket and that all contact surfaces are undamaged and clean.

To gain access to the connector block within the cable socket, remove the central screw and withdraw the hinged cover.

The connector block on the standard PA20 may be rotated in 90° steps to facilitate wiring:

- Remove the retaining screw and hinged cover and withdraw the socket.
- Remove the connector block and reposition as required. **Note:** It is not possible to rotate the connector block on the UL Version.

4.4 Additional wiring information - UL listed version

The preamplifier is supplied with four 18 AWG, 12" long colour coded flying leads. These are to be cut to length and connected to a suitable metal terminal box. A length of flexible metal conduit is required between the preamplifier and the terminal box to provide environmental protection and simple electrical connection. The cable socket is provided with a ½" NPT conduit adaptor for this purpose. 18-16 AWG screened cable is recommended between the terminal and the controller.

WARNING

The flying leads supplied with the probe are rated to 221°F (105°C). This temperature rating must not be exceeded.

The flexible conduit and terminal box are not to incorporate any other control wiring as this may damage or reduce the performance of the product.

It is not possible to rotate the cable socket in 90° steps, as with the standard PA20, as this may damage the internal wiring.

Care must be taken to ensure that any condensation which might build up in the conduit network is prevented from accumulating in the probe cable connector and terminal box. Drain/vent holes must be kept clear - do not cover.

Before applying power to the PA20, disconnect the cable socket and ensure that 15-35 Vdc is present between Pin 1 and the earth terminals.

4.5 Wiring connections – both versions (Figure 5)

| | | | |
|----------------|----------|--------------|--|
| Terminal 1 | (Brown) | Supply | * The sensitivity connection is made in the terminal box for the UL listed version. Terminal 3: This terminal provides three different sensitivity range settings, depending on the way it is wired (see Section 4.6 below). |
| Terminal 2 | (Red) | Output | |
| Terminal 3 | (Orange) | Sensitivity* | |
| Earth terminal | (Black) | Common | |

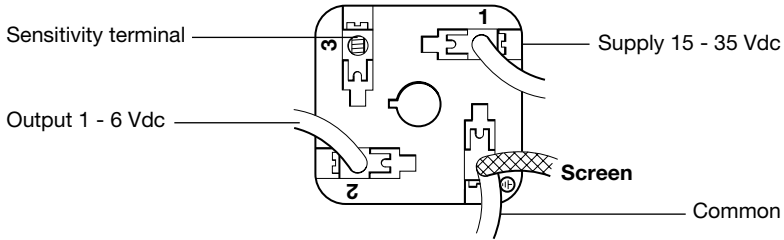

Fig. 6 Top view of connector block removed from its housing (Medium sensitivity).

4.6 Sensitivity settings

Fig. 7 High sensitivity
(Up to 500 mm (20") immersed length) **Link 1 + 3**
(Including all probes up to 550 mm length)

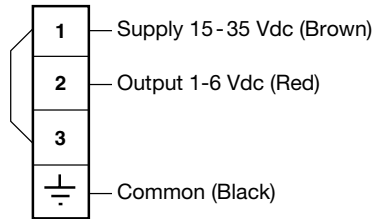

Fig. 8 Medium sensitivity
(Up to 1050 mm (41") immersed length) **No link**

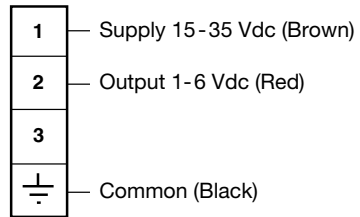
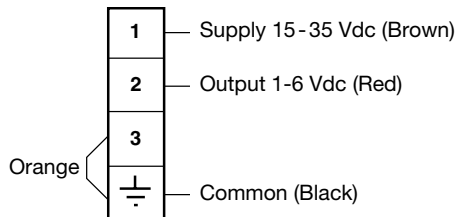

Fig. 9 Low sensitivity
(Longer immersed lengths) **Link 3 + Earth**



5. Voltage check (both versions)

Carry out the following voltage check before commissioning the controller:-

1. Switch the controller on, then raise the water level to the highest level that it is required to measure. For steam boilers, this is normally the top of the level gauge glass.
2. Check that the dc voltage between terminal 2 (red) and the earth/common (black) terminal of the preamplifier is between 3 and 6 volts dc.
3. **If it is more than 6 volts**, select the next lowest sensitivity range by changing terminal 3 wiring as shown in Figures. 6, 7 and 8.
4. **If it is less than 3 volts**, change to next highest sensitivity range, where available.
5. Check that the voltage is now between 3 and 6 volts.
6. **If it is still more than 6 volts**, select the lowest sensitivity range.

The graph (Figure 10) shows the approximate preamplifier voltage to be expected when a probe is immersed by a given amount.

The exact voltage depends on how the probe is installed and the length of probe fitted.

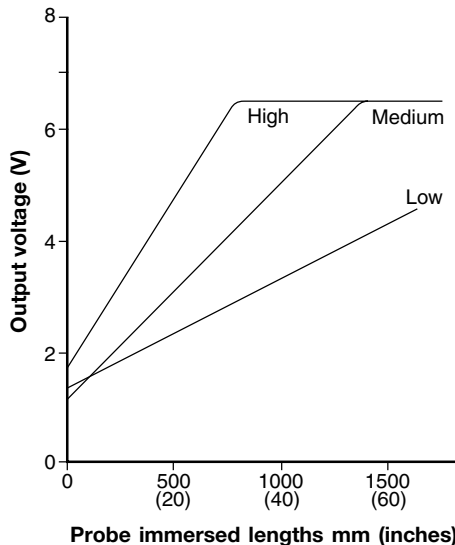

Fig. 10

Ensure that high sensitivity is selected when probes of between 370 and 550 mm are fitted. Selecting medium or low sensitivity may cause the 'out of range' function (if fitted or selected) to go to alarm.

6. Maintenance

Probe body cleaning instructions - Use a cloth dampened with tap/de-ionised water or isopropyl alcohol. Use of other cleaning materials could damage the product and invalidate the warranty.

Boiler water level controls - Require regular testing and inspection. For specific testing instructions for Spirax Sarco systems please see separate literature.