

**No. 8**

**Fixed Temperature Liquid Expansion Steam Trap**  
**Installation and Maintenance Instructions**

---

---

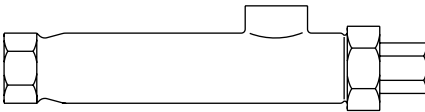

- 1. Safety information*
- 2. General  
safety information*
- 3. Installation*
- 4. Commissioning*
- 5. Operation*
- 6. Maintenance*
- 7. Spare parts*

---

# 1. Safety information

---

Safe operation of this product can only be guaranteed if it is properly installed, commissioned, used and maintained by qualified personnel (see Section 1.11) in compliance with the operating instructions. General installation and safety instructions for pipeline and plant construction, as well as the proper use of tools and safety equipment must also be complied with.

## 1.1 Intended use

Referring to the Installation and Maintenance Instructions, name-plate and Technical Information Sheet, check that the product is suitable for the intended use/application. This product complies with the requirements of the European Pressure Equipment Directive 97/23/EC. This product falls within the following Pressure Equipment Directive categories:

Product	Group 2 Gases	Group 2 Liquids
No.8	SEP	SEP

- i) This product has been specifically designed for use on steam, air or water/condensate which are in Group 2 of the above mentioned Pressure Equipment Directive. The products' use on other fluids may be possible but, if this is contemplated, Spirax Sarco should be contacted to confirm the suitability of the product for the application being considered.
- ii) Check material suitability, pressure and temperature and their maximum and minimum values. If the maximum operating limits of the product are lower than those of the system in which it is being fitted, or if malfunction of the product could result in a dangerous overpressure or overtemperature occurrence, ensure a safety device is included in the system to prevent such over-limit situations.
- iii) Determine the correct installation situation and direction of fluid flow.
- iv) Spirax Sarco products are not intended to withstand external stresses that may be induced by any system to which they are fitted. It is the responsibility of the installer to consider these stresses and take adequate precautions to minimise them.
- v) Remove protection covers from all connections before installation.

## 1.2 Access

Ensure safe access and if necessary a safe working platform (suitably guarded) before attempting to work on the product. Arrange suitable lifting gear if required.

## 1.3 Lighting

Ensure adequate lighting, particularly where detailed or intricate work is required.

## 1.4 Hazardous liquids or gases in the pipeline

Consider what is in the pipeline or what may have been in the pipeline at some previous time. Consider: flammable materials, substances hazardous to health, extremes of temperature.

---

## 1.5 Hazardous environment around the product

Consider: explosion risk areas, lack of oxygen (e.g. tanks, pits), dangerous gases, extremes of temperature, hot surfaces, fire hazard (e.g. during welding), excessive noise, moving machinery.

## 1.6 The system

Consider the effect on the complete system of the work proposed. Will any proposed action (e.g. closing isolation valves, electrical isolation) put any other part of the system or any personnel at risk?

Dangers might include isolation of vents or protective devices or the rendering ineffective of controls or alarms. Ensure isolation valves are turned on and off in a gradual way to avoid system shocks.

## 1.7 Pressure systems

Ensure that any pressure is isolated and safely vented to atmospheric pressure before attempting to maintain the product. Consider double isolation (double block and bleed) and the locking or labelling of closed valves. Alternatively, fit Spirax Sarco depressurisation valves type DV (see separate literature for details). Do not assume that the system has depressurised even when the pressure gauge indicates zero.

## 1.8 Temperature

Allow time for temperature to normalise after isolation to avoid danger of burns.

## 1.9 Tools and consumables

Before starting work ensure that you have suitable tools and/or consumables available. Use only genuine Spirax Sarco replacement parts.

## 1.10 Protective clothing

Consider whether you and/or others in the vicinity require any protective clothing to protect against the hazards of, for example, chemicals, high/low temperature, radiation, noise, falling objects, and dangers to eyes and face.

## 1.11 Permits to work

All work must be carried out or be supervised by a suitably competent person. Installation and operating personnel should be trained in the correct use of the product according to the Installation and Maintenance Instructions.

Where a formal 'permit to work' system is in force it must be complied with. Where there is no such system, it is recommended that a responsible person should know what work is going on and, where necessary, arrange to have an assistant whose primary responsibility is safety.

Post 'warning notices' if necessary.

## 1.12 Handling

Manual handling of large and/or heavy products may present a risk of injury. Lifting, pushing, pulling, carrying or supporting a load by bodily force can cause injury particularly to the back. You are advised to assess the risks taking into account the task, the individual, the load and the working environment and use the appropriate handling method depending on the circumstances of the work being done.

---

### **1.13 Residual hazards**

In normal use the external surface of the product may be very hot. If used at the maximum permitted operating conditions the surface temperature of the product may reach temperatures in excess of 250°C (482°F).

Many products are not self-draining. Take due care when dismantling or removing the product from an installation (refer to 'Maintenance instructions').

### **1.14 Freezing**

Provision must be made to protect products which are not self-draining against frost damage in environments where they may be exposed to temperatures below freezing point.

### **1.15 Disposal**

This product is recyclable and no ecological hazard is anticipated with its disposal providing due care is taken.

### **1.16 Returning products**

Customers and stockists are reminded that under EC Health, Safety and Environment Law, when returning products to Spirax Sarco they must provide information on any hazards and the precautions to be taken due to contamination residues or mechanical damage which may present a health, safety or environmental risk. This information must be provided in writing including Health and Safety data sheets relating to any substances identified as hazardous or potentially hazardous.

## — 2. General product information —

### 2.1 General description

The No.8 fixed temperature liquid expansion thermostatic steam trap has an oil filled element set to operate at a fixed temperature. It is easily adjusted to discharge at any temperature between 60°C and 100°C (140°F and 212°F).

Note: For additional information see Technical Information Sheet TI-P018-01.

### 2.2 Sizes and pipe connections

½" screwed BSP or NPT.

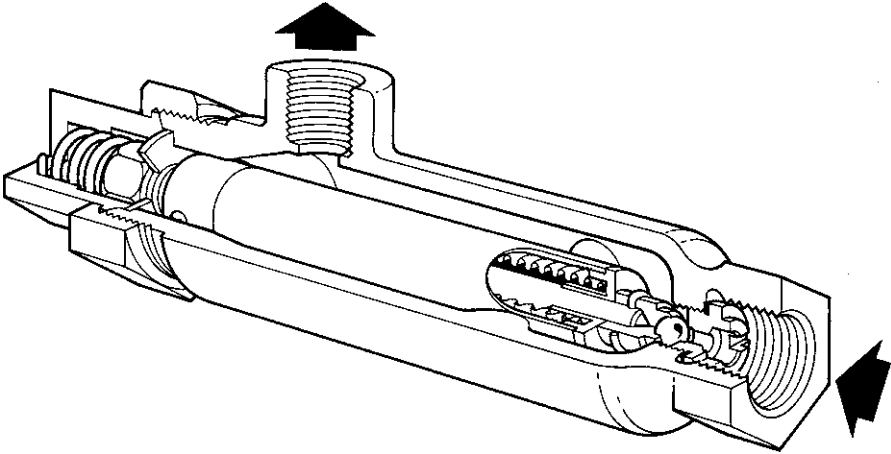
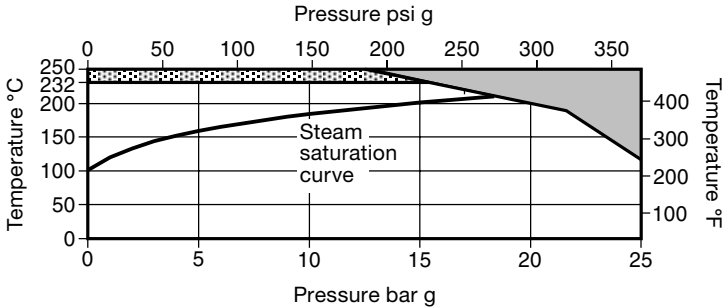



Fig. 1 No.8 fixed temperature liquid expansion steam trap

## 2.3 Pressure / temperature limits



 The product **must not** be used in this region.

 The product should not be used in this region or beyond its operating range as damage to the internals may occur.

Body design conditions			PN25
PMA	Maximum allowable pressure	25 bar g @ 110°C	(327 psi g @ 230°F)
TMA	Maximum allowable temperature	250°C @ 12 bar g	(482°F @ 174 psi)
Minimum allowable temperature		-29°C	(-20°F)
PMO	Maximum operating pressure for saturated steam service	17 bar g	(247 psi g)
TMO	Maximum operating temperature	232°C @ 15 bar g	(450°F @ 218 psi)
Minimum operating temperature		0°C	(32°F)
<b>Note:</b> For lower operating temperatures consult Spirax Sarco.			
Designed for a maximum cold hydraulic test pressure of:		38 bar g	(551 psi g)

# 3. Installation

**Note:** Before actioning any installation observe the 'Safety information' in Section 1.

Referring to the Installation and Maintenance Instructions, body markings and Technical Information Sheet, check that the product is suitable for the intended installation:

- 3.1** Check materials, pressure and temperature and their maximum values. If the maximum operating limit of the product is lower than that of the system in which it is being fitted, ensure that a safety device is included in the system to prevent overpressurisation.
- 3.2** Determine the correct installation situation and the direction of fluid flow.
- 3.3** Remove protective covers from all connections, where appropriate, before installation on steam or other high temperature applications.
- 3.4** The trap should be installed with the inlet below the equipment being drained. The outlet should always be above the trap.
- 3.5** Because of its fixed temperature discharge characteristic, the liquid expansion trap may be usefully employed as a 'shutdown drain trap'. Its outlet must always point upwards, as illustrated in Figure 2, to enable continuous immersion of the oil filled element, and be routed via an open ended drain terminating below its body to a safe place. As it can only discharge between 60°C - 100°C (140°F - 212°F), it needs to be installed in conjunction with a 'normal' mains drain trap which would usually be piped to a condensate return line.
- 3.6** Isolation valves must be installed to allow for safe maintenance and trap replacement.
- 3.7** Open isolation valves slowly until normal operating conditions are achieved.
- 3.8** Check for leaks and correct operation.

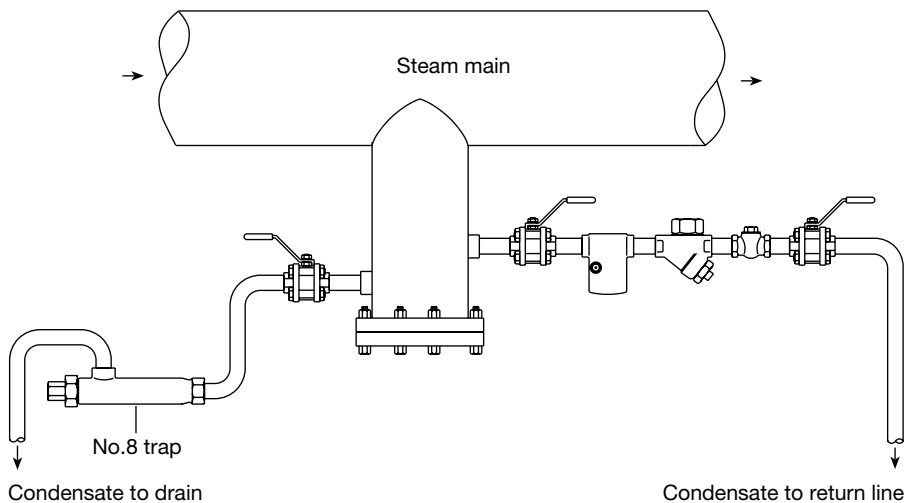

**Fig. 2**

---

## *4. Commissioning*

---

After installation or maintenance ensure that the system is fully functioning. Carry out tests on any alarms or protective devices.

---

## *5. Operation*

---

The Spirax Sarco No.8 fixed temperature liquid expansion trap is one of the simplest thermostatic traps which is currently available. Under cold conditions, such as start-up, the oil filled element is fully off it's seat allowing unrestricted removal of cold condensate, air and other incondensables. As hot condensate enters through the trap, the oil filled element heats up and expands, closing the valve against the seat. The adjustment of the element allows the temperature of the trap discharge i.e. the temperature at which the valve opens again, to be altered between 60°C and 100°C (140°F and 212°F) simply by turning the adjustment nut (see Section 6, Maintenance).



# 6. Maintenance

**Note:** Before actioning any maintenance programme observe the 'Safety information' in Section 1.

## 6.1 General information

Before undertaking any maintenance on the trap it must be isolated from both the supply line and return line and any pressure allowed to safely normalise to atmosphere. The trap should then be allowed to cool. When reassembling, ensure that all joint faces are clean.

## 6.2 Adjustment

**Note:** The No.8 fixed temperature liquid expansion trap is calibrated in the factory, but may require initial adjustment as follows:

- Loosen the adjustment lock-nut (5) situated at the end of the trap.
- Turning the adjustment nut (1) which serves one end of the element (8) can alter the position of the valve head (9) relative to the valve seat (11) and, therefore, the operating temperature.
- Turning the adjustment nut (1) anticlockwise will allow condensate to be released at an increased temperature, therefore hotter.
- Turning the adjustment nut (1) clockwise will allow condensate to be released at a decreased temperature, therefore cooler.
- Retighten the adjustment lock-nut (5) to the recommended torque (see Table 1, page 10), ensuring that the adjustment nut (1) doesn't move at the same time.
- Isolation valves should be opened slowly to allow the pressure and temperature to build up in a controlled manner.
- Check for leaks.

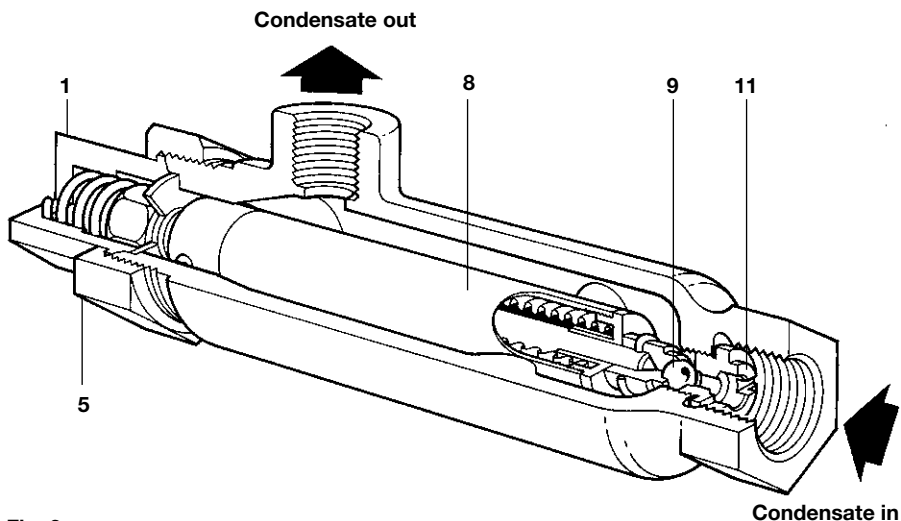

Fig. 3

### 6.3 How to change the element set:

- Remove the trap from the line, unscrew the adjustment lock-nut (5), remove the adjustment nut (1) and lift out the element (8).
- Unscrew the valve seat (11) using a screwdriver through the inlet connection and replace with the new valve seat (11) and gasket (10) then proceed to tighten to the recommended torque (see Table 1).
- Insert the new element (8) taking care to locate the round-head guide screw (6) in the slot.
- Fit a new overload spring (2) and replace the adjustment nut (1) and adjustment lock-nut (5) then proceed to tighten to the recommended torque (see Table 1).
- Refit the trap into the pipeline and reset.
- Isolation valves should be opened slowly to allow the pressure and temperature to build up in a controlled manner.
- Check for leaks.

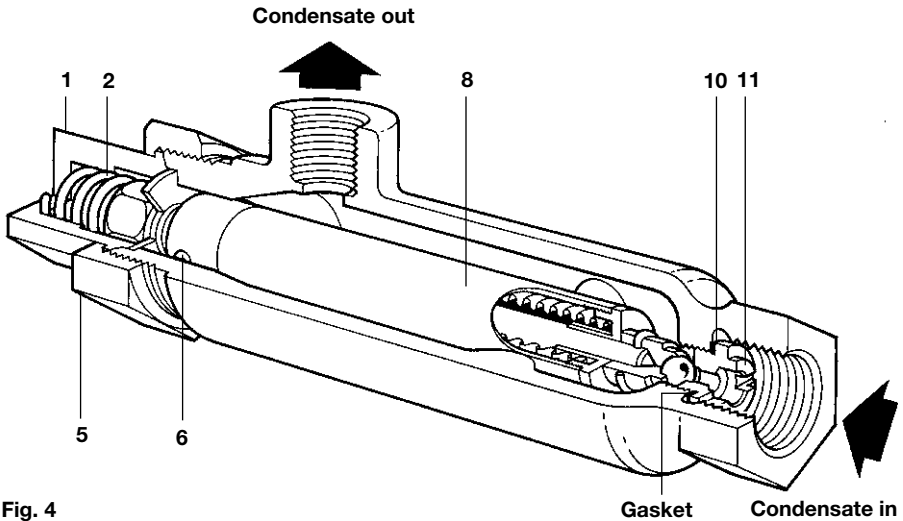



Fig. 4

Table 1 Recommended tightening torques

Item No.	Part	mm	N m	(lbf ft)
		or		
11	Valve seat	 1/2" UNF	30 - 35	(22 - 26)
5	Adjustment lock-nut	11 <sup>15</sup> / <sub>32</sub> " A/F	80 - 85	(59 - 63)

# 7. Spare parts

The spare parts available are shown in solid outline. Parts drawn in broken line are not supplied as spares.

## Available spares

Element set

2, 8, 10, 11

## How to order spares

Always order spares by using the description given in the column headed 'Available spares' and state the size and type of trap.

**Example:** 1 - Element set for a 1/2" Spirax Sarco No.8 fixed temperature liquid expansion steam trap.

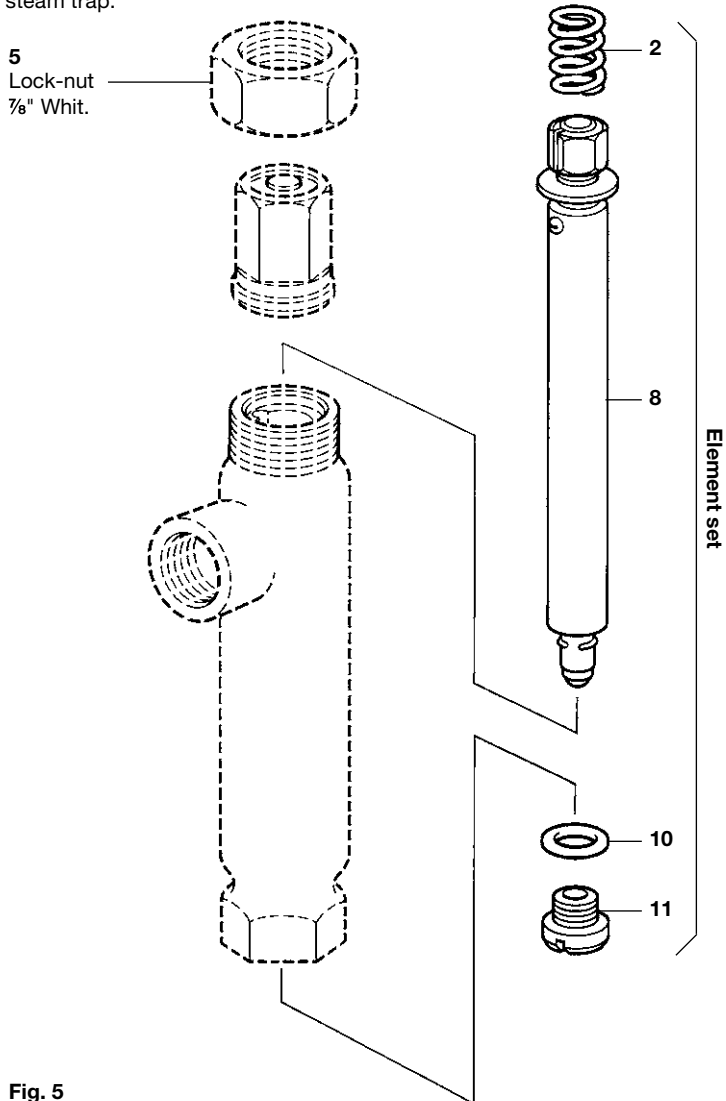

Fig. 5

