

MR1M, MRN1M and MR2M
Monnier Miniature Compressed Air Regulators
Installation and Maintenance Instructions



1. Safety information
2. General product information
3. Installation and commissioning
4. Operation
5. Spare parts and Maintenance

1. Safety information

Safe operation of these products can only be guaranteed if they are properly installed, commissioned, used and maintained by qualified personnel (see Section 1.11) in compliance with the operating instructions. General installation and safety instructions for pipeline and plant construction, as well as the proper use of tools and safety equipment must also be complied with.

1.1 Intended use

Referring to the Installation and Maintenance Instructions, name-plate and Technical Information Sheet, check that the product is suitable for the intended use/application. The products comply with the requirements of the European Pressure Equipment Directive 97/23/EC and fall within the category 'SEP'. It should be noted that products within this category are required by the Directive not to carry the CE mark.

- i) The products have been specifically designed for use on compressed air, which is in Group 2 of the above mentioned Pressure Equipment Directive. The products' use on other fluids may be possible but, if this is contemplated, Spirax Sarco should be contacted to confirm the suitability of the product for the application being considered.
- ii) Check material suitability, pressure and temperature and their maximum and minimum values. If the maximum operating limits of the product are lower than those of the system in which it is being fitted, or if malfunction of the product could result in a dangerous overpressure or overtemperature occurrence, ensure a safety device is included in the system to prevent such over-limit situations.
- iii) Determine the correct installation situation and direction of fluid flow.
- iv) Spirax Sarco products are not intended to withstand external stresses that may be induced by any system to which they are fitted. It is the responsibility of the installer to consider these stresses and take adequate precautions to minimise them.
- v) Remove protection covers from all connections and protective film from all name-plates, where appropriate, before installation on steam or other high temperature applications.

1.2 Access

Ensure safe access and if necessary a safe working platform (suitably guarded) before attempting to work on the product. Arrange suitable lifting gear if required.

1.3 Lighting

Ensure adequate lighting, particularly where detailed or intricate work is required.

1.4 Hazardous liquids or gases in the pipeline

Consider what is in the pipeline or what may have been in the pipeline at some previous time. Consider: flammable materials, substances hazardous to health, extremes of temperature.

1.5 Hazardous environment around the product

Consider: explosion risk areas, lack of oxygen (e.g. tanks, pits), dangerous gases, extremes of temperature, hot surfaces, fire hazard (e.g. during welding), excessive noise, moving machinery.

1.6 The system

Consider the effect on the complete system of the work proposed. Will any proposed action (e.g. closing isolation valves, electrical isolation) put any other part of the system or any personnel at risk?

Dangers might include isolation of vents or protective devices or the rendering ineffective of controls or alarms. Ensure isolation valves are turned on and off in a gradual way to avoid system shocks.

1.7 Pressure systems

Ensure that any pressure is isolated and safely vented to atmospheric pressure. Consider double isolation (double block and bleed) and the locking or labelling of closed valves. Do not assume that the system has depressurised even when the pressure gauge indicates zero.

1.8 Temperature

Allow time for temperature to normalise after isolation to avoid danger of burns.

1.9 Tools and consumables

Before starting work ensure that you have suitable tools and/or consumables available. Use only genuine Spirax Sarco replacement parts.

1.10 Protective clothing

Consider whether you and/or others in the vicinity require any protective clothing to protect against the hazards of, for example, chemicals, high/low temperature, radiation, noise, falling objects, and dangers to eyes and face.

1.11 Permits to work

All work must be carried out or be supervised by a suitably competent person. Installation and operating personnel should be trained in the correct use of the product according to the Installation and Maintenance Instructions.

Where a formal 'permit to work' system is in force it must be complied with. Where there is no such system, it is recommended that a responsible person should know what work is going on and, where necessary, arrange to have an assistant whose primary responsibility is safety.

Post 'warning notices' if necessary.

1.12 Handling

Manual handling of large and/or heavy products may present a risk of injury. Lifting, pushing, pulling, carrying or supporting a load by bodily force can cause injury particularly to the back. You are advised to assess the risks taking into account the task, the individual, the load and the working environment and use the appropriate handling method depending on the circumstances of the work being done.

1.13 Residual hazards

In normal use the external surface of the product may be very hot. If used at the maximum permitted operating conditions the surface temperature of some products may reach temperatures of 90°C (194°F).

Many products are not self-draining. Take due care when dismantling or removing the product from an installation (refer to 'Maintenance instructions').

1.14 Freezing

Provision must be made to protect products which are not self-draining against frost damage in environments where they may be exposed to temperatures below freezing point.

1.15 Disposal

Unless otherwise stated in the Installation and Maintenance Instructions, this product is recyclable and no ecological hazard is anticipated with its disposal providing due care is taken.

1.16 Returning products

Customers and stockists are reminded that under EC Health, Safety and Environment Law, when returning products to Spirax Sarco they must provide information on any hazards and the precautions to be taken due to contamination residues or mechanical damage which may present a health, safety or environmental risk. This information must be provided in writing including Health and Safety data sheets relating to any substances identified as hazardous or potentially hazardous.

2. General product information

2.1 General description

The MR_M Monnier range of miniature compressed air regulators provide accurate pressure control for general purpose pneumatic systems where space is restricted and flowrates are low.

Principal features:

- Good flow characteristics.
- Good regulation characteristics.
- Fast response.
- Dead tight shut-off on no-flow.
- For bracket or panel mounting.
- External black anodised finish.

Available types:

MR1M	Self-relieving
MRN1M	Non-relieving
MR2M	Self-relieving

Optional extras:

For further technical information regarding the following options see page 6:

- Type 3 mounting bracket.
- Easy fit stainless steel bowl guard.

2.2 Sizes and pipe connections

1/4" screwed BSP (BS 21-Rp).

2.3 Spring range (operating pressure range)

All regulators can be adjusted to zero pressure, or up to the figures shown. The operating range is marked on the unit.

Standard spring	0.7 - 9.0 bar g
Optional spring	0.2 - 2.0 bar g 0.3 - 4.0 bar g

Note: This range of miniature compressed air regulators are supplied with the standard spring unless an alternative option was specified when the initial order was placed.



Fig. 1 MR1M Monnier miniature compressed air regulator

Please note: These products incorporate a common body and internal components, (except for the use of a Non-relieving diaphragm - when specified).

2.4 Operating limits

Maximum pressure/temperature	21 bar g @ 70°C	(304 psi g @ 158°F)
-------------------------------------	-----------------	---------------------

2.5 Materials

Part		Material
Body	MR1M and MRN1M	Aluminium
	MR2M	Aluminium and polycarbonate
Valve		Nitrile

— 3. Installation and Commissioning —

Note: Before actioning any installation observe the 'Safety information' in Section 1.

Referring to the Installation and Maintenance Instructions, name-plate and Technical Information Sheet, check that the product is suitable for the intended installation.

3.1 General information

MR_M

Dimensions/weights
(approximate) in mm and kg

Type	A	B	C	Weight
MR1M	11	89	36	0.095
MRN1M	11	89	36	0.095
MR2M	11	78	36	0.085

Mounting kit - The MR1M, MR2M and MRN1M regulators may be used with an optional mounting kit consisting of bracket (Type 8 or Type 4), mounting ring and pressure gauge. Mounting kits are supplied separately. Fasteners are not included.

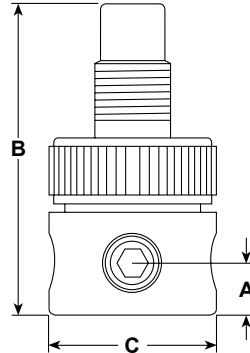

Fig. 2

Type 8 mounting bracket and mounting ring (MR2M only)

For panel mounting: An aluminium mounting ring is to be specified.

For bracket mounting: A Type 8 mounting bracket and aluminium mounting ring is to be specified.

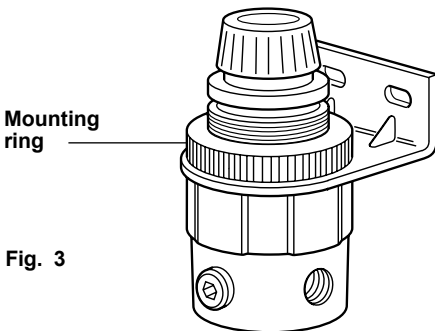
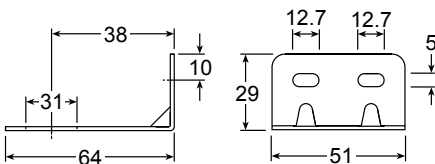

Fig. 3

Dimensions (approximate) in millimetres



Type 4 mounting bracket (MR1M only)

An angle bracket in zinc plated mild steel to enable the regulator to be mounted behind the panel. The regulator is attached to the bracket by a screwed nipple.

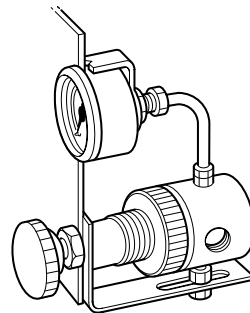
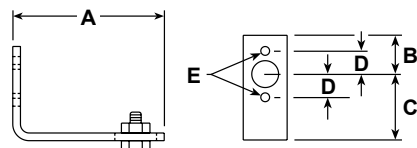

Fig. 4

Dimensions (approximate) in mm

A	B	C	D	EØ
69	15.9	27	9.5	4BA (3.6 mm)



Pressure gauges

Available in two sizes, with 4 pressure ranges. The face is marked in both bar and psi. The 40 mm gauge will be supplied unless the 50 mm is specified on the order.

	0 to 2 bar	0 to 30 psi
	0 to 7 bar	0 to 100 psi
Pressure ranges	0 to 11 bar	0 to 160 psi
	0 to 21 bar	0 to 300 psi (50 mm size only)

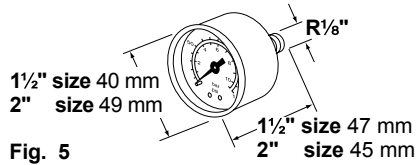

Fig. 5

Pressure gauges for panel mounting

With chromium plated bezel available in two ranges, the face being marked in bar and psi as follows:-

Pressure ranges	0 to 2 bar	0 to 30 psi
	0 to 7 bar	0 to 100 psi

Dimensions (approximate) in mm

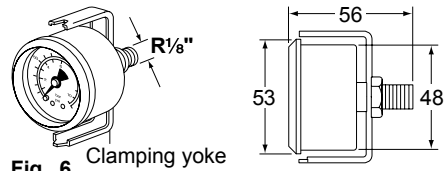

Fig. 6

3.2 Installation

- 3.2.1 The unit can be fitted in either vertical or horizontal pipework.
- 3.2.2 Connect the unit so that the airflow is in the direction indicated by the arrow on the body.
- 3.2.3 The unit should be installed as close as possible to the equipment it is serving.
- 3.2.4 A pressure gauge fitted to one of the ports is recommended (to show the secondary pressure) as is a miniature filter in front of the regulator to keep dirt out. The port(s) not in use should be blanked off with the plugs supplied.
- 3.2.5 **Panel mounting the MR2M:** The panel must not exceed 8 mm thick. The required hole is 31 mm.

3.3 Adjustment

It is recommended that all adjustments are made under flow conditions:

- Lift the yellow locking ring (1) on the MR2M, or loosen the lock-nut on the MR1M (see Fig. 1).
- Turn the adjustment knob (2) clockwise to increase the secondary pressure, or anticlockwise to decrease it.
- Depress the yellow locking ring (1) or retighten the lock-nut to re-lock.
- There will be a slight increase in set pressure when flow stops.

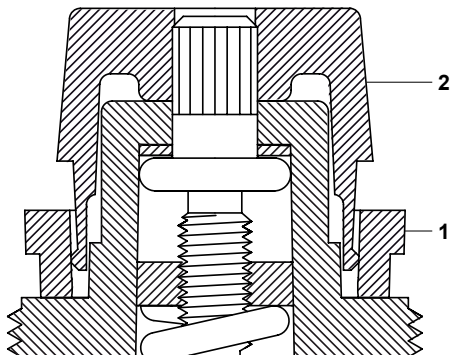

Fig. 7

4. Operation

4.1 Principle of operation

With system pressure on, the regulator poppet valve assembly is in the closed position when the adjusting knob is turned fully counter clockwise (no spring load). By turning the adjusting knob clockwise, the diaphragm / piston moves downward allowing flow to come in through the orifice created between the poppet assembly and seat. The control diaphragm / piston offsetting the load spring senses pressure downstream. Increasing downstream pressure causes the poppet assembly to move upward until the load of the spring and diaphragm / piston are balanced. The outlet pressure has now been reduced. If a valve is opened downstream, the increased demand for pressure creates a reduced pressure under the control diaphragm / piston. The poppet assembly moves downward due to the load of the control spring opening the seat area and air is allowed to meet the downstream pressure demand. Thus, the area of the opening meters the downstream flow.

4.2 Capacities

For safety valve sizing purposes the full lift capacities for the MR1M and MR2M is $0.21 K_{VS}$.

Performance (with primary pressure 10 bar)

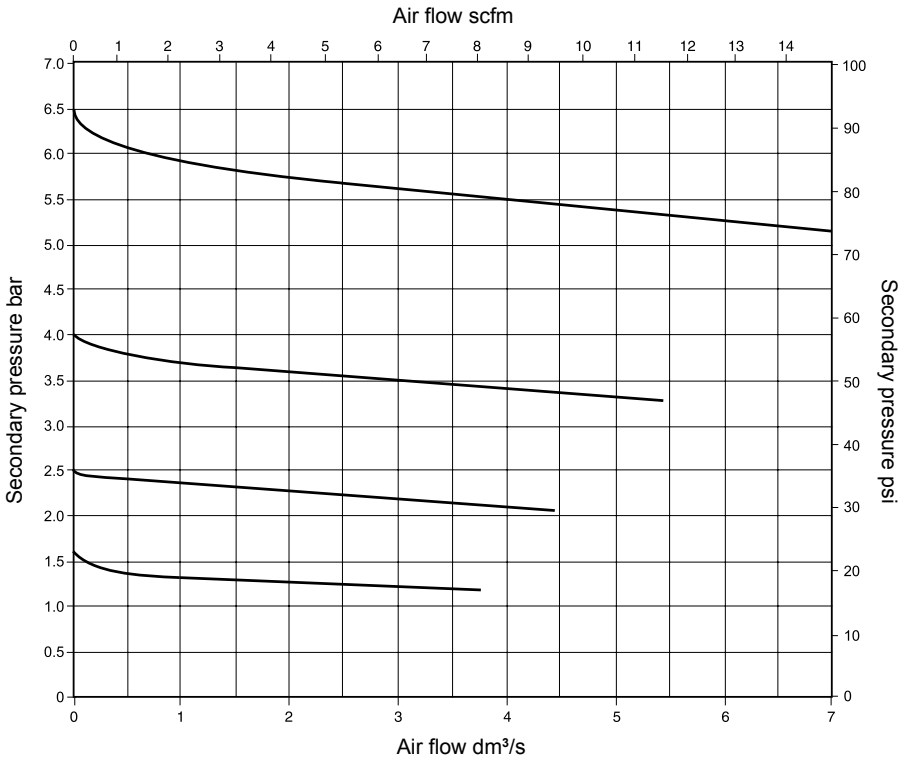

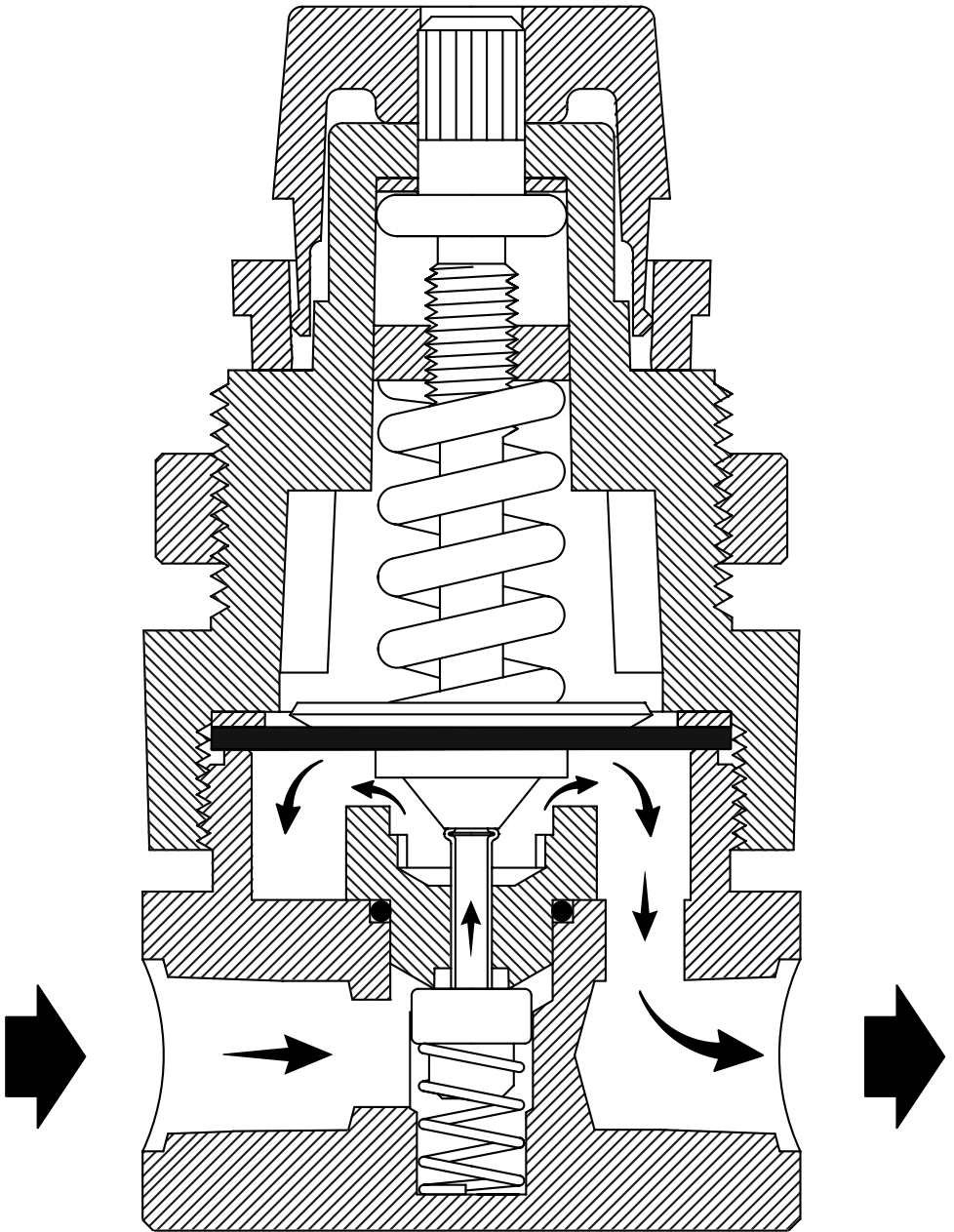

Fig. 8 Operation

— 5. Spare parts and Maintenance —

5.1 Spare parts

There are no serviceable spare parts for these units. However, should you require a new unit please order your request as follows:

How to order

Example: 1 off MR1M Monnier miniature compressed air regulator having ¼" screwed BSP connections and a 0.2 to 2 bar control spring.

Notes:

1. The MR1M or MR2M regulator will be supplied with a 0.7 to 9 bar spring as standard.
2. See Section 2 regarding the available spring range and optional extras.

5.2 Maintenance

These products require no maintenance.

