

MP2M and MPN2M Monnier Miniature Compressed Air Filter/Regulators

Installation and Maintenance Instructions



MP2M

shown with optional pressure gauge

1. Safety information
2. General product information
3. Installation and commissioning
4. Operation
5. Spare parts and maintenance

1. Safety information

Safe operation of these products can only be guaranteed if they are properly installed, commissioned, used and maintained by qualified personnel (see Section 1.11) in compliance with the operating instructions. General installation and safety instructions for pipeline and plant construction, as well as the proper use of tools and safety equipment must also be complied with.

1.1 Intended use

Referring to the Installation and Maintenance Instructions, name-plate and Technical Information Sheet, check that the product is suitable for the intended use/application. The products comply with the requirements of the European Pressure Equipment Directive 2014/68/EU and fall within the category 'SEP'.

It should be noted that products within this category are required by the Directive not to carry the  mark.

- i) The products have been specifically designed for use on compressed air, which is in Group 2 of the above mentioned Pressure Equipment Directive. The products' use on other fluids may be possible but, if this is contemplated, Spirax Sarco should be contacted to confirm the suitability of the product for the application being considered.
- ii) Check material suitability, pressure and temperature and their maximum and minimum values. If the maximum operating limits of the product are lower than those of the system in which it is being fitted, or if malfunction of the product could result in a dangerous overpressure or overtemperature occurrence, ensure a safety device is included in the system to prevent such over-limit situations.
- iii) Determine the correct installation situation and direction of fluid flow.
- iv) Spirax Sarco products are not intended to withstand external stresses that may be induced by any system to which they are fitted. It is the responsibility of the installer to consider these stresses and take adequate precautions to minimise them.
- v) Remove protection covers from all connections and protective film from all name-plates, where appropriate, before installation on steam or other high temperature applications.

1.2 Access

Ensure safe access and if necessary a safe working platform (suitably guarded) before attempting to work on the product. Arrange suitable lifting gear if required.

1.3 Lighting

Ensure adequate lighting, particularly where detailed or intricate work is required.

1.4 Hazardous liquids or gases in the pipeline

Consider what is in the pipeline or what may have been in the pipeline at some previous time. Consider: flammable materials, substances hazardous to health, extremes of temperature.

1.5 Hazardous environment around the product

Consider: explosion risk areas, lack of oxygen (e.g. tanks, pits), dangerous gases, extremes of temperature, hot surfaces, fire hazard (e.g. during welding), excessive noise, moving machinery.

1.6 The system

Consider the effect on the complete system of the work proposed. Will any proposed action (e.g. closing isolation valves, electrical isolation) put any other part of the system or any personnel at risk? Dangers might include isolation of vents or protective devices or the rendering ineffective of controls or alarms. Ensure isolation valves are turned on and off in a gradual way to avoid system shocks.

1.7 Pressure systems

Ensure that any pressure is isolated and safely vented to atmospheric pressure. Consider double isolation (double block and bleed) and the locking or labelling of closed valves. Do not assume that the system has depressurised even when the pressure gauge indicates zero.

1.8 Temperature

Allow time for temperature to normalise after isolation to avoid danger of burns.

1.9 Tools and consumables

Before starting work ensure that you have suitable tools and/or consumables available. Use only genuine Spirax Sarco replacement parts.

1.10 Protective clothing

Consider whether you and/or others in the vicinity require any protective clothing to protect against the hazards of, for example, chemicals, high/low temperature, radiation, noise, falling objects, and dangers to eyes and face.

1.11 Permits to work

All work must be carried out or be supervised by a suitably competent person. Installation and operating personnel should be trained in the correct use of the product according to the Installation and Maintenance Instructions.

Where a formal 'permit to work' system is in force it must be complied with. Where there is no such system, it is recommended that a responsible person should know what work is going on and, where necessary, arrange to have an assistant whose primary responsibility is safety.

Post 'warning notices' if necessary.

1.12 Handling

Manual handling of large and/or heavy products may present a risk of injury. Lifting, pushing, pulling, carrying or supporting a load by bodily force can cause injury particularly to the back. You are advised to assess the risks taking into account the task, the individual, the load and the working environment and use the appropriate handling method depending on the circumstances of the work being done.

1.13 Residual hazards

In normal use the external surface of the product may be very hot. If used at the maximum permitted operating conditions the surface temperature of some products may reach temperatures of 90 °C (194 °F).

Many products are not self-draining. Take due care when dismantling or removing the product from an installation (refer to 'Maintenance instructions').

1.14 Freezing

Provision must be made to protect products which are not self-draining against frost damage in environments where they may be exposed to temperatures below freezing point.

1.15 Disposal

Unless otherwise stated in the Installation and Maintenance Instructions, this product is recyclable and no ecological hazard is anticipated with its disposal providing due care is taken.

Please visit the Spirax Sarco product compliance web pages

<https://www.spiraxsarco.com/product-compliance>

for up to date information on any substances of concern that may be contained within this product. Where no additional information is provided on the Spirax Sarco product compliance web page, this product may be safely recycled and/or disposed providing due care is taken. Always check your local recycling and disposal regulations.

1.16 Returning products

Customers and stockists are reminded that under EC Health, Safety and Environment Law, when returning products to Spirax Sarco they must provide information on any hazards and the precautions to be taken due to contamination residues or mechanical damage which may present a health, safety or environmental risk. This information must be provided in writing including Health and Safety data sheets relating to any substances identified as hazardous or potentially hazardous.

2. General product information

2.1 General description

The Monnier miniature compressed air filter/regulators provide high quality compressed air, with accurate pressure control, for general purpose pneumatic systems where space is restricted and flowrates are low.

Principal features:

- Compact combined miniature filter/regulator.
- Long life 5 µm element.
- Improved moisture separation with multi-bladed whirl disc.
- Fast response.
- Polycarbonate bowl.
- For line, bracket or panel mounting.
- Good flow and regulation characteristics.
- External black anodised finish.

Optional extras:

For further technical information regarding the following options see page 6:

- Airset kit - The MP2M, MPN2M regulators may be used with an optional airset kit consisting of Type 8 bracket, mounting ring and pressure gauge. Airset kits are supplied separately. Please note that fasteners are not included.
- Easy fit stainless steel bowl guard.

2.2 Sizes and pipe connections

¼" screwed BSP T Rp (ISO 7-1).

2.3 Spring range

All regulators can be adjusted to zero pressure, or up to the figures shown.
The operating range is marked on the unit.

2.4 Operating limits

Maximum pressure/temperature	Polycarbonate bowl	10 bar g @ 50 °C (145 psi g @ 122 °F)
	Metal bowl	17 bar g @ 80 °C (246.5 psi g @ 176 °F)

2.5 Materials

Part	Material
Body	Aluminium and polycarbonate
Valve	Nitrile rubber
Element (5 mm)	Sintered polypropylene
Bowl	Polycarbonate
Bowl guard (optional extra)	Stainless steel



Fig. 1 MP2M Monnier miniature compressed air filter/regulator

3. Installation and commissioning

Note: Before actioning any installation observe the 'Safety information' in Section 1.

Referring to the Installation and Maintenance Instructions, name-plate and Technical Information Sheet, check that the product is suitable for the intended installation.

3.1 Specific product safety information

Polycarbonate bowls may be attacked by phosphate ester based fluids, solvents, chemical cleaners, carbon tetrachloride, etc. These and any other substances should not be allowed to come into contact with this component. Certain compressor lubricating oils also contain additives harmful to polycarbonate. Where there is any doubt we recommend, in the interests of personal safety, that bowl guards or metal bowls be fitted.

3.2 Installation

- 3.3.1** The unit should be fitted in horizontal pipework with the bowl vertically downwards.
- 3.3.2** Adequate space should be provided around the unit to allow easy access for routine servicing requirements (see TI-P504-05 for withdrawal distances).
- 3.3.3** Connect the unit so that the airflow is in the direction indicated by the arrow on the body.
- 3.3.4** The unit should be installed as close as possible to the equipment it is serving.
- 3.3.5** The body has two R $\frac{1}{8}$ " ports, one of which is available for fitting a pressure gauge to register the secondary pressure. In the event that a pressure gauge is not fitted, this port should be blanked off with the blank plug provided. Ensure that the range of the pressure gauge corresponds with that of the main control spring as indicated on the unit. The second port should not be used for any purpose and is sealed with a factory fitted plug which should not be removed.
- 3.3.6** Do not overload the filter cartridge (see Section 4 - Operating principals) or there will be a reduction in its efficiency and/or life. On heavily contaminated systems, it is advisable to fit a conventional pneumatic filter (Monnier International or Miniature) immediately in front of the unit for maximum efficiency and life cycle.
- 3.3.7** The polycarbonate bowl may be fitted with a bowl guard.
- 3.3.8 Panel mounting:** The panel must not exceed 8 mm thick. The required hole is 31 mm.

3.4 Adjustment

It is recommended that all adjustments are made under flow conditions:

- Lift the locking ring (2).
- Turn the adjustment knob (1) clockwise to increase the pressure.
- Depress the locking ring (2) to lock.
- There will be a slight increase in set pressure when the flow stops.

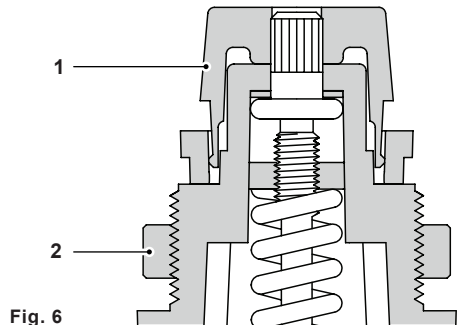

4. Operation

4.1 Principle of operation

With system pressure on, the regulator poppet valve assembly is in the closed position when the adjusting knob is turned fully counter clockwise (no spring load). By turning the adjusting knob clockwise, the diaphragm / piston moves downward allowing filtered air to flow in through the orifice created between the poppet assembly and seat. The control diaphragm / piston offsetting the load spring senses pressure downstream. Increasing downstream pressure causes the poppet assembly to move upward until the load of the spring and diaphragm / piston are balanced. The outlet pressure has now been reduced. If a valve is opened downstream, the increased demand for pressure creates a reduced pressure under the control diaphragm / piston. The poppet assembly moves downward due to the load of the control spring opening the seat area and air is allowed to meet the downstream pressure demand. Thus, the area of the opening meters the downstream flow.

4.2 Performance selection (with primary pressure 10 bar)

For any specified primary filtration pressure, there is a maximum recommended air flowrate. Keeping within this, will ensure that the element performance maintains the stated high efficiency levels, particularly for the removal of oil and water contaminants.

4.3 Capacities

The full lift capacities for safety valve sizing purposes is 0.21 K_{VS} .

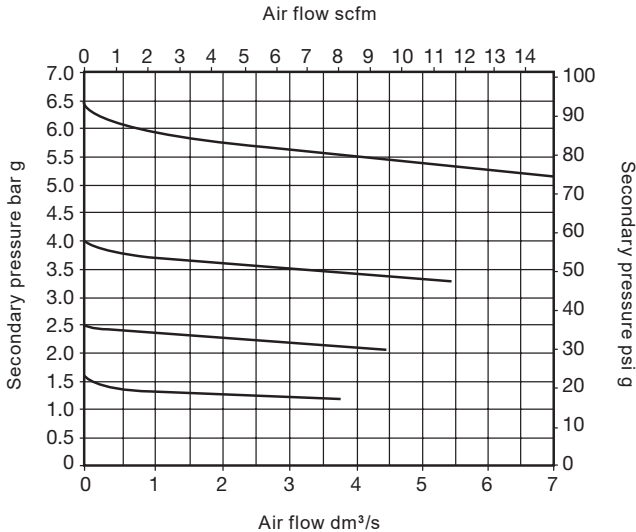

The graph utilises some typical values for secondary flow/pressure to demonstrate droop

$$\text{Droop} = \frac{\text{Pressure droop}}{\text{Set point}} @ \text{Relevant flowrate}$$

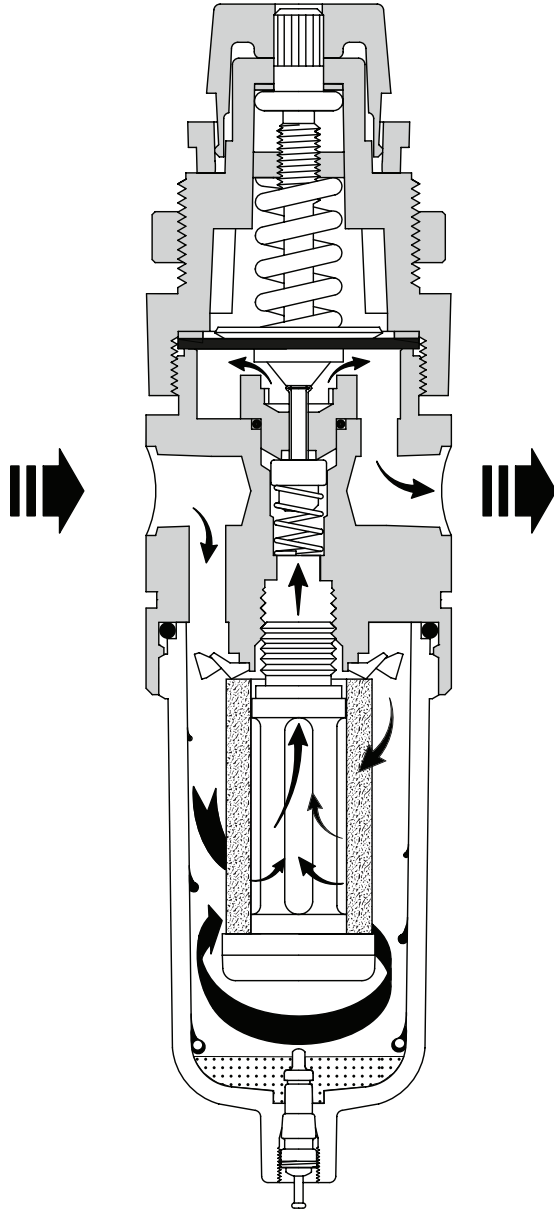

Fig. 7 Operation

5. Spare parts and maintenance

5.1 Spare parts

The spare parts available are detailed below.
No other parts are supplied as spares.

Available spares

Polycarbonate bowl assembly	A, B
Element set 5 micron (packet of 3)	B, C
Panel/bracket mounting ring	D
Bowl guard assembly (optional extra)	X, Y

Note: In the interests of safety Spirax Sarco recommend that a bowl guard (an optional extra) should be fitted to polycarbonate bowls.

How to order spares

Always order spares by using the description given in the column headed 'Available spares' and state the size and type of unit.

Example:

1 - Element set (5 micron) for a 1/4" MP2M Monnier miniature compressed air filter/regulator.

5.2 Maintenance

To service the filter (no tools required):

- Isolate the main air supply.
- Remove the bowl guard if fitted.
- Release the pressure by opening the manual drain or gently unscrewing the bowl (A) until the pressure relieves.
- Remove the bowl (A) and unscrew the element retaining nut and withdraw the filter assembly (C).
- Clean the bowl (A) using soap and water only (do not use solvents or proprietary cleaners) and wipe dry with a lint free cloth.
- Reassemble in reverse order using a new element (C), ensuring that the element 'O' ring (B) is fitted.
- The bowl should be firmly hand tightened.

