

M850-W and M850-P Flow Computers

Installation and Maintenance Instructions



M850-W



M850-P

1. Contents

2. Safety information	8
------------------------------	----------

3. General product and delivery information	12
3.1 Equipment delivery, handling and storage	
3.2 Purpose	13
3.3 Available options	14
3.4 Basic functions	15
3.5 Assistance, service, returns and decommissioning	17

4. System overview	18
4.1 Orifice plate installation for steam	
4.2 Orifice plate installation for gases	20
4.3 Gilflo plate installation for steam	22
4.4 Gilflo plate installation for gases	24
4.5 ILVA plate installation for steam	26
4.6 ILVA plate installation for gases	28

5. Product familiarisation

		30
5.1	Front panel	
5.2	Process values layout in A, B, C, X, Y and Z application	33
5.3	Screens navigation	36
5.4	Main menu	41
5.5	Communication with the master system	42
5.6	Messages	
		44
5.7	Authorised functions, user login and logout	
5.8	Archive screen	49
5.9	Archiving control of the current results	50
5.10	Browsing the archived measurement results	52
5.11	Totaliser archive	53
5.12	Alarms and control	54
5.13	Control functions	
5.14	Failure notification of measurement inputs	55
5.15	User defined characteristics	
5.16	Audit trail	56

6. Internal memory

61

7. Technical information for the M850-W and M850-P **62**

8. Mechanical installation **68**

8.1 Mounting instructions for the wall mounted B850-W **70**

8.2 Mounting instructions for the panel mounted B850-P **74**

9. Electrical installation **75**

9.1 Important - Please read the following general wiring notes:

9.2 Important - Please read the following general mains wiring notes **77**

9.3 Cable/wire and connector data **78**

9.4 Power supply connection **88**

9.5 Connecting the RTD type sensors

9.6 Analog current loop transmitters 0 / 4 - 20 mA **89**

9.7 Connecting transmitters with PULS type inputs **90**

9.8 Connecting the receiver to the 4 - 20 mA analog output **91**

9.9 Connecting receivers to binary outputs (RL1 to RL4) **92**

9.10 Connecting data transmission lines to the RS-485/RS-422 port **93**

9.11 Connecting the device to the LAN using the Ethernet port **94**

9.12 USB port

10. Commissioning

10.1	Content of the settings menu	95
10.2	Basis of configuration	97
10.3	Configuration sequence	101
10.4	Selection of the measuring system	
10.5	Auxiliary process values and auxiliary applications	124
10.6	Units	128
10.7	Relay outputs and event messages	131
10.8	Measuring inputs	135
10.9	Alarm and control thresholds	142
10.10	Totalisers	144
10.11	4 - 20 mA current loop output (optional)	147
10.12	Archiving	148
10.13	RS-485/RS-422 serial port	151
10.14	Ethernet port	152
10.15	Text messages	154
10.16	Display configuration	155
10.17	Summer and winter time - automatic adjustment	159
10.18	Saving to and loading settings from a file	
10.19	M850 flow computer commissioning using PC software for quick start-up	161

11. Functions only available to the administrator

11.1	Changing the Administrator Password	172
11.2	Administrator menu	
11.3	New firmware	174
11.4	Restoring factory settings	
11.5	Test of inputs and outputs	175
11.6	Functions available only for service	

12. Test functions

12.1	Test of inputs and outputs	176
12.2	Port RS-485/RS-422	177

13. MODBUS protocol

13.1	Serial transmission parameters and general information	178
13.2	Ethernet port settings for Modbus TCP	
13.3	Readout of current results and totalisers	179
13.4	Process values (main and auxiliary values) – register addresses	180
13.5	Totalisers	185
13.6	Clock read out and setting	
13.7	Error code	193

14. BACnet communications

14.1	BACnet Objects	194
14.2	BACnet Services	
14.3	List of supported services in the M850	
14.4	List of supported BACnet Objects in the M850	195
14.5	Addressing BACnet Objects in the M850	
14.6	Instance numbers for main values	196
14.7	Instance numbers for totalizers of the main values	198
14.8	Instance numbers of auxiliary values	200
14.9	Instance numbers for totalizers of auxiliary values	201
14.10	Setting BACnet MSTP communication in the M850	202
14.11	Setting BACnet IP communication in the M850	

Certain computer programs contained in this product [or device] were developed by Spirax-Sarco Limited ('the Work(s)').

Copyright © Spirax-Sarco Limited 2026

All Rights Reserved

Spirax-Sarco Limited grants the legal user of this product (or device) the right to use the Work(s) solely within the scope of the legitimate operation of the product (or device). No other right is granted under this licence. In particular and without prejudice to the generality of the foregoing, the Work(s) may not be used, sold, licensed, transferred, copied or reproduced in whole or in part or in any manner or form other than as expressly granted here without the prior written consent of Spirax-Sarco Limited.

Manufacturer

Spirax Sarco Limited, Runnings Road, Cheltenham, GL51 9NQ
www.spiraxsarco.com

2. General product information





Safe operation of this product can only be guaranteed if it is properly installed, commissioned, used and maintained by qualified personnel (see the following sections) in compliance with the operating instructions. General installation and safety instructions for pipeline and plant construction, as well as the proper use of tools and safety equipment must also be complied with.

In the UK, your attention is drawn to IEE Regulations (BS 7671). Elsewhere, other regulations will normally apply. All wiring materials and methods shall comply with relevant EN and IEC standards where applicable. This product must be installed indoors only



Warning

This product is designed and constructed to withstand the forces encountered during normal use. Use of the product other than as a steam flow computer, or failure to install the product in accordance with these Instructions, product modifications or repair could:

- Cause damage to the product / property.
- Cause injury or fatality to personnel.
- Invalidate the  and  marks.

Isolate the mains supply before opening the product as hazardous voltages may be exposed. These instructions must be stored in a safe place near the installation of the steam flow computer at all times.



Warning

This product complies with the requirements of the following directives and harmonized standards:

Low Voltage Directive by meeting the standards of:

- EN 61010-1 Safety requirements for electrical equipment for measurement, control and laboratory use.

Electromagnetic Compatibility Directive by meeting the standards of:

- Immunity EN 61326-1 Table 2
- Radiated and conducted emissions EN 61326-1 Group 1 Class B.

The product may be exposed to interference above the limits of EN 61326 if:

- The product or its wiring is located near a radio transmitter.
Excessive electrical noise occurs on the mains supply. Power line protectors (ac) should be installed if mains supply noise is likely. Protectors can combine filtering, suppression, surge and spike arrestors.
- Cellular telephones and mobile radios may cause interference if used within approximately 1 metre (39") of the product or its wiring. The actual separation distance necessary will vary according to the surroundings of the installation and the power of the transmitter.

2.1 Intended use

- i) Check that the product is suitable for use with the application.
- ii) Determine the correct installation situation.
- iii) Spirax Sarco products are not intended to withstand external stresses that may be induced by any system to which they are fitted. It is the responsibility of the installer to consider these stresses and take adequate precautions to minimise them.

2.2 Access

Ensure safe access and if necessary a safe working platform (suitably guarded) before attempting to work on the product.

2.3 Lighting

Ensure adequate lighting, particularly where detailed or intricate work is required.

2.4 Hazardous environment around the product

Consider: explosion risk areas, lack of oxygen (e.g. tanks, pits), dangerous gases, extremes of temperature, hot surfaces, fire hazard (e.g. during welding), excessive noise, moving machinery.

2.5 The system

Consider the effect on the complete system of the work proposed. Will any proposed action (e.g. closing isolation valves, electrical isolation) put any other part of the system or any personnel at risk? Dangers might include isolation of vents or protective devices or the rendering ineffective of controls or alarms. Ensure isolation valves are turned on and off in a gradual way to avoid system shocks.

2.6 Tools and consumables

Before starting work ensure that you have suitable tools and / or consumables available.

2.7 Protective clothing

Consider whether you and / or others in the vicinity require any protective clothing to protect against the hazards of, for example, chemicals, high/low temperature, radiation, noise, falling objects, and dangers to eyes and face.

2.8 Permits to work

All work must be carried out or be supervised by a suitably competent person. Installation and operating personnel should be trained in the correct use of the product according to the Installation and Maintenance Instructions. Where a formal 'permit to work' system is in force it must be complied with. Where there is no such system, it is recommended that a responsible person should know what work is going on and, where necessary, arrange to have an assistant whose primary responsibility is safety. Post 'warning notices' if necessary.

2.9 Handling

Manual handling of large and/or heavy products may present a risk of injury. Lifting, pushing, pulling, carrying or supporting a load by bodily force can cause injury particularly to the back. You are advised to assess the risks taking into account the task, the individual, the load and the working environment and use the appropriate handling method depending on the circumstances of the work being done. Arrange suitable lifting gear if required.

2.10 Disposal

The M850 contains a battery. On disposal of the unit or component, appropriate precautions should be taken in accordance with Local/National regulations.

Unless otherwise stated in the Installation and Maintenance Instructions, with the exception of the battery, this product is recyclable and no ecological hazard is anticipated with its disposal providing due care is taken.

2.11 Returning products

Customers and stockists are reminded that under EC Health, Safety and Environment Law, when returning products to Spirax Sarco they must provide information on any hazards and the precautions to be taken due to contamination residues or mechanical damage which may present a health, safety or environmental risk. This information must be provided in writing including Health and Safety data sheets relating to any substances identified as hazardous or potentially hazardous.

The symbols, used on the product, mean:



Equipment protected throughout by double insulation or reinforced insulation.



Functional earth (ground) terminal, to enable the product to function correctly. Not used to provide electrical safety.



Caution, risk of electric shock.



Caution, risk of danger, refer to accompanying documentation.

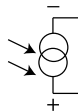

Optically isolated current source or sink.



Caution, Electrostatic Discharge (ESD) sensitive circuit. Do not touch or handle without proper electrostatic discharge precautions.



ac - alternating current



dc - direct current

3. General product and delivery information

The M850 forms part of a flowmetering system and is used with the Spirax Sarco range of flowmeters: Gilflo, ILVA, linear flowmeters and orifice plate assemblies - See Section 4 'System overview' which illustrates the complete system. Depending on the application, it may also be supplied with a differential pressure transmitter, pressure transmitter and/or a temperature transmitter.

These Installation and Maintenance Instructions will enable the rapid connection and commissioning of the flowmetering system.

All the details for this are displayed in a simple and easy to read format.

3.1 Equipment delivery, handling and storage

Factory shipment

Prior to shipment, the Spirax Sarco M850 is tested, calibrated and inspected to ensure proper operation.

Receipt of shipment

Each carton should be inspected at the time of delivery for possible external damage. Any visible damage should be recorded immediately on the carrier's copy of the delivery slip. Each carton should be unpacked carefully and its contents checked for damage:

Content of M850-P

- 1 x Flow computer M850-P
- 2 x Fixing clamps
- 1 x Printed Quickstart Guide
- 1 x USB (Full installation and maintenance instructions, configuration software)
- 1 x Set of terminal blocks
- 1 x Carton package

Content of M850-W

- 1 x Flow computer M850-W
- 1 x Printed Quickstart Guide
- 1 x USB (Full installation and maintenance instructions, configuration software)
- 1 x Carton package

If it is found that some items have been damaged or are missing, notify Spirax Sarco immediately and provide full details. In addition, damage must be reported to the carrier with a request for their on-site inspection of the damaged item and its shipping carton.

Storage

If a flow computer is to be stored for a period prior to installation, the environmental storage conditions should be at a temperature between -30 °C and 70 °C (-22 °F and 158 °F), and between 5% and 95% relative humidity (non-condensing).

Before installing and connecting the power ensure there is no condensation within the unit.

3.2 Purpose

M850-P and M850-W devices are microprocessor based, universal flow computers designed for measurement of:

- Flow and heat of steam and water according to IAPWS-IF97,
- Flow and heat of liquids other than water according to characteristics provided by user,
- Flow of technical gases.

M850 flow computers can be used for three different applications of an installation. The flow computers are designated for industrial application in independent measurement applications and as component of computerized measurement and control systems. Implemented math functions enable calculation of flow and energy balances. Extended functions of events and process values recording make it possible to perform analysis of technological processes and alarm conditions. Data recording of process values enables to use this device in places beyond the reach of computer networks. Four output relays provide with signaling and simple control functions. The flow computers are a freely programmable in a broad range and enables configuration of displaying the results depending on user's needs. Comprehensive programming menu allows simple configuration of the instrument.

The device has a panel mount or wall mount construction for indoor industrial applications.

Flow computers can work with the following flowmeters:

- Differential pressure devices ILVA and Giflo type,
- Differential pressure devices (orifices and nozzles) according to iteration algorithm according to PN EN ISO 5167 standard (only for water and steam),
- Differential pressure devices with approximation by square root curve,
- Volume flowmeters,
- Mass flowmeters.
- Devices are available in six language versions: English, French, German, Spanish, Portugese or Polish. Language change is available from the device keyboard.

3.3 Available options

Both versions of the M850 series have the same functions and are available as follows:

- **M850-P** for panel mounting and is powered by 24 Vdc.
- **M850-W** for wall mounting and has been adapted to be powered by 100/240 Vac.

Additionally, each version can be optionally equipped with one or two analog outputs 4 - 20 mA.

Available versions:

M850	-x	
	-P	Panel mounted version
	-W	Wall mounted version
	-0	Option without analog 4 - 20 mA output
	-1	Option with one analog 4 - 20 mA output
	-2	Option with two analog 4 - 20 mA outputs

3.4 Basic functions

- Measuring channels

The M850 has 12 available inputs; analog, RTD and pulse:

	4 - 20 mA	0 - 20 mA	Pt100	Ni100	PULS*
IN1	+	+			
IN2	+	+			
IN3	+	+			
IN4	+	+			
IN5	+	+			
IN6	+	+			
IN7			+	+	
IN8			+	+	
IN9			+	+	
IN10					+
IN11					+
IN12					+

* **PULS - type inputs** can operate in three modes:

- **State monitoring**, can follow binary signal shorting (closing)/opening; each of the two binary states can be assigned to any analog value (e.g. -1.00/10.0);

Value corresponding to the binary state can be used for simple control or as a value in the math functions (e.g. direction of flow);

- **Frequency measurement** in the range 0.001 Hz ...10 kHz; programmable frequency range allows calibration of the measured value to engineering units (e.g. flow);
- **Pulse counting** should be chosen if a flowmeter with a constant pulse value was connected to the binary input.

Inputs can work with a passive signals (reed-type contact, or OC transistor signals), active voltage signals and the NAMUR standard.

- Math functions and additional measurements

There are 8 channels that can be assigned to an unassigned input as an additional measurement or value calculated from a formula in which can be used measurements value, other calculated values and constant values in the operations of additions, difference, multiplication, division and square root. This allows e.g. to make a balance of flows and energy, the calculation of the average value and the quotient of two values.

- Totalisers

For each measurement inputs, both binary inputs and for each calculated value can be assigned two independent totalisers. Additionally can be attributed totaliser which reset itself every certain period of time (hour/day/month) and totaliser of exceedances triggered after exceeding the preset value.

- Results logging

The results of measurements, calculations and the states of totalisers may be recorded in the device's internal memory with a capacity of 2 GB. The data are stored in text form and secure by encrypted checksum. Additionally can be recorded the events (power interruptions, change of settings, exceedance of alarm and control thresholds, etc.) and authorised activities. The internal memory may contain maximum of 250 files.

- Results displaying

On the front panel there is backlit TFT LCD graphic display and three tri-color LEDs.

Depending on the configuration, results of measurements and calculations are presented in digital form (big numbers), analog lines, the table of min/max/average value or in a graph. They can also be displayed collectively in the form of tables that are individually configurable. There is a possibility of sequential displaying screens.

- Keypad - function keys

This device is equipped with seven function buttons. The buttons have changeable functions, depending on the currently displayed information. In addition there is 12-button keypad for numbers and letters entering.

- Relay outputs

Four relays outputs can be assigned to alarm and control thresholds, allow to implement a signalization of exceedance and a simple two-state control. Relays can also be configured to work as pulse outputs. Then a relay is assigned to one of the available totalisers. Number of pulses corresponds to totaliser incrementation. M850-P version has low power solid-state relays, whilst M850-W has electromechanical power relays.

- Current loop outputs 4 - 20 mA (optional)

M850 devices can be equipped with one or two optional analog current loop outputs 4 - 20 mA. These outputs allow to send a signal linearly dependent on any chosen value (measured or calculated). The loop has to be powered by an external voltage source (by connected receiver supply). Current outputs are galvanically isolated from other circuits of the flow computer.

- Communication with a computer system

The unit can be connected to the master computer system by:

- Built-in serial RS-485 port; available is ASCII own protocol and Modbus RTU protocol.
- Ethernet port, available is web server and Modbus TCP protocol.
- In addition, the RS-485 port can be used to connect the GSM module, it enables transfer of information about failures, alarms and measurement values in the form of SMS text messages.

- Report software

Additional software – 850-REPORT, for easier viewing archived results, together with the basic mathematical processing and data selection.

3.5 Assistance, service, returns and decommissioning



3.5.1 For technical assistance

Contact your local Spirax Sarco representative. Details can be found on order/delivery documentation or on our web site: www.spiraxsarco.com

3.5.2 Service, Maintenance and Cleaning

No special servicing, preventative maintenance or inspection of the product is required. For cleaning, use a dry cloth. Do not use detergent or water.

3.5.3 Serviceable parts

There are no user serviceable parts, battery is good for the life of the product.

3.5.4 Returning faulty equipment

Please return all items to your local Spirax Sarco representative. Please ensure all items are suitably packed for transit (preferably in the original cartons).

Please provide the following information with any equipment being returned:

1. Your name, company name, address and telephone number, order number and invoice and return delivery address.
2. Description and serial number of equipment being returned.
3. Full description of the fault or repair required.
4. If the equipment is being returned under warranty, please indicate:
 - Date of purchase.
 - Original order number.

3.5.5 Decommissioning

If the product is to be decommissioned please pay full attention to all sections of Section 2 - Safety Information.

4. System overview

4.1 Orifice plate installation for steam

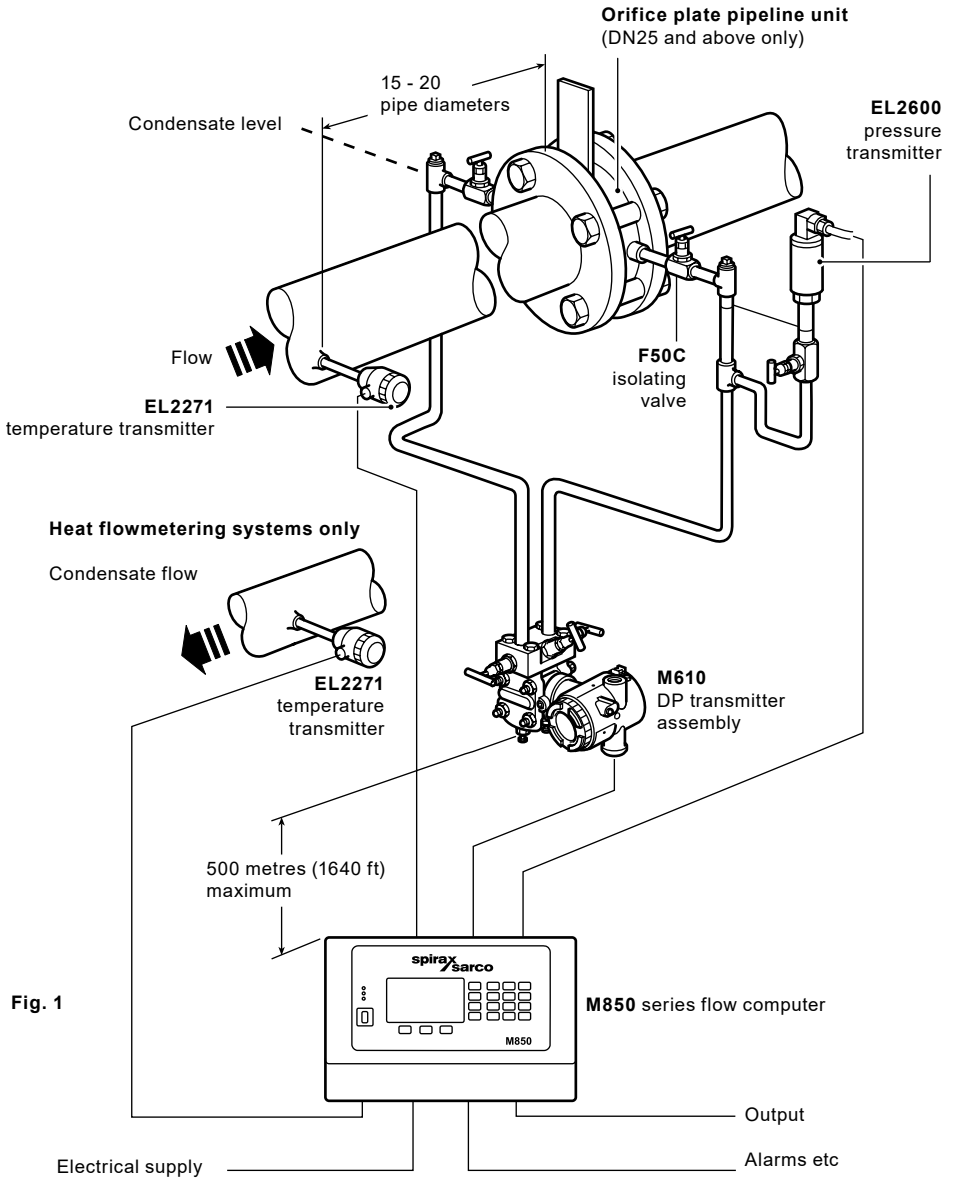

M850-W and M850-P Flow Computers

Installation points to watch:-

1. Ensure all pipework is adequately supported and properly aligned.
2. The minimum recommended lengths of straight pipe are 10 D upstream and 5 D downstream. For full details refer to BS 1042/ISO 5167.
3. Take care to ensure the correct direction of flow as indicated by the arrow on the flowmeter body. Also ensure that the 45° chamfer on the orifice plate is facing downstream and that the drain hole is at the bottom.
4. Avoid installing the flowmeter downstream of a pressure reducing valve as this may cause inaccuracies. Similarly, avoid installing the flowmeter downstream of a partially open valve.
5. Adequate line drainage should be provided upstream of the flowmeter for all steam applications.
6. Please read Section 9 before wiring the system.

4.2 Orifice plate installation for gases

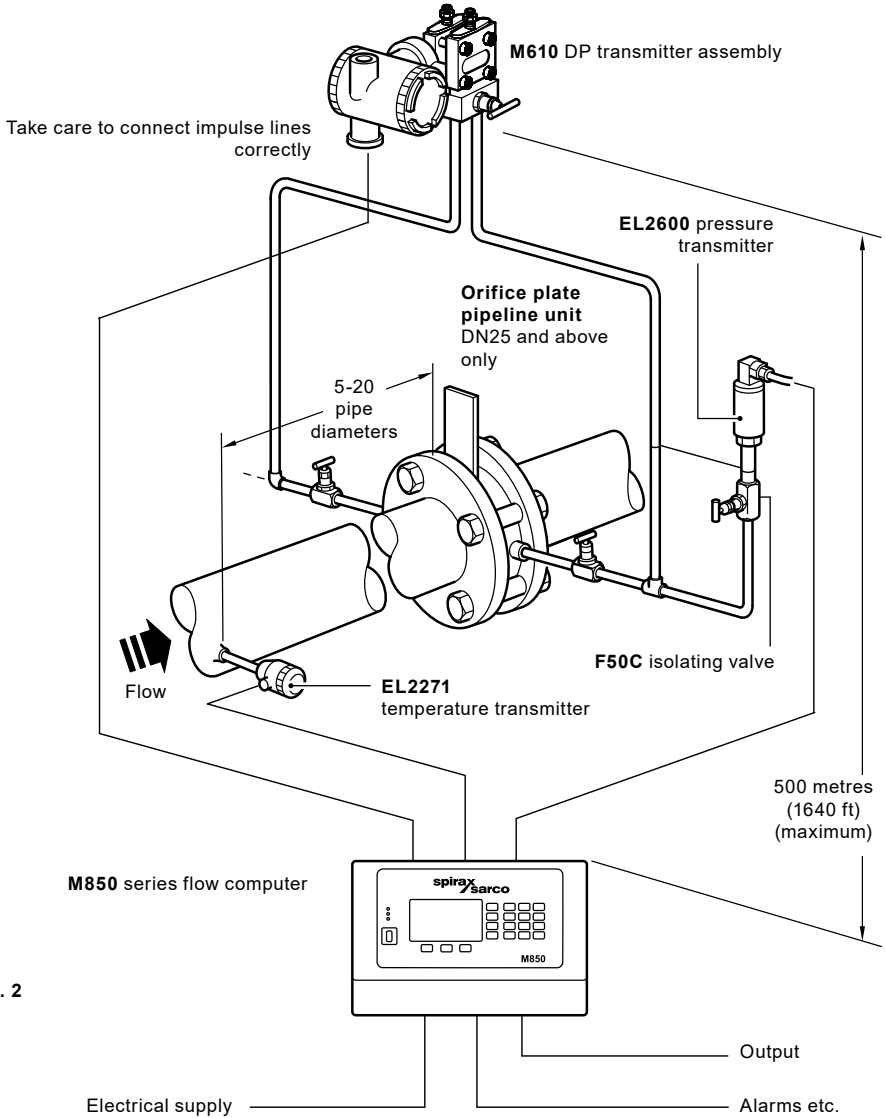

Fig. 2

Installation points to watch:-

1. Ensure all pipework is adequately supported and properly aligned.
2. The minimum recommended lengths of straight pipe are 6 D upstream and 3 D downstream.
3. Take care to ensure the correct direction of flow as indicated by the arrow on the flowmeter body.
4. Take precautions to avoid reverse flow through the flowmeter.
5. Avoid installing the flowmeter downstream of a pressure reducing valve as this may cause inaccuracies and/or possibly damage. Similarly, avoid installing the flowmeter downstream of a partially open valve.
6. Remember that actuated valves may cause rapid pressure fluctuations which could cause some damage.
7. Take care not to exceed temperature limitation for pressure and temperature transmitters.
8. Please read Section 9 before wiring the system.

4.3 Gilflo installation for steam

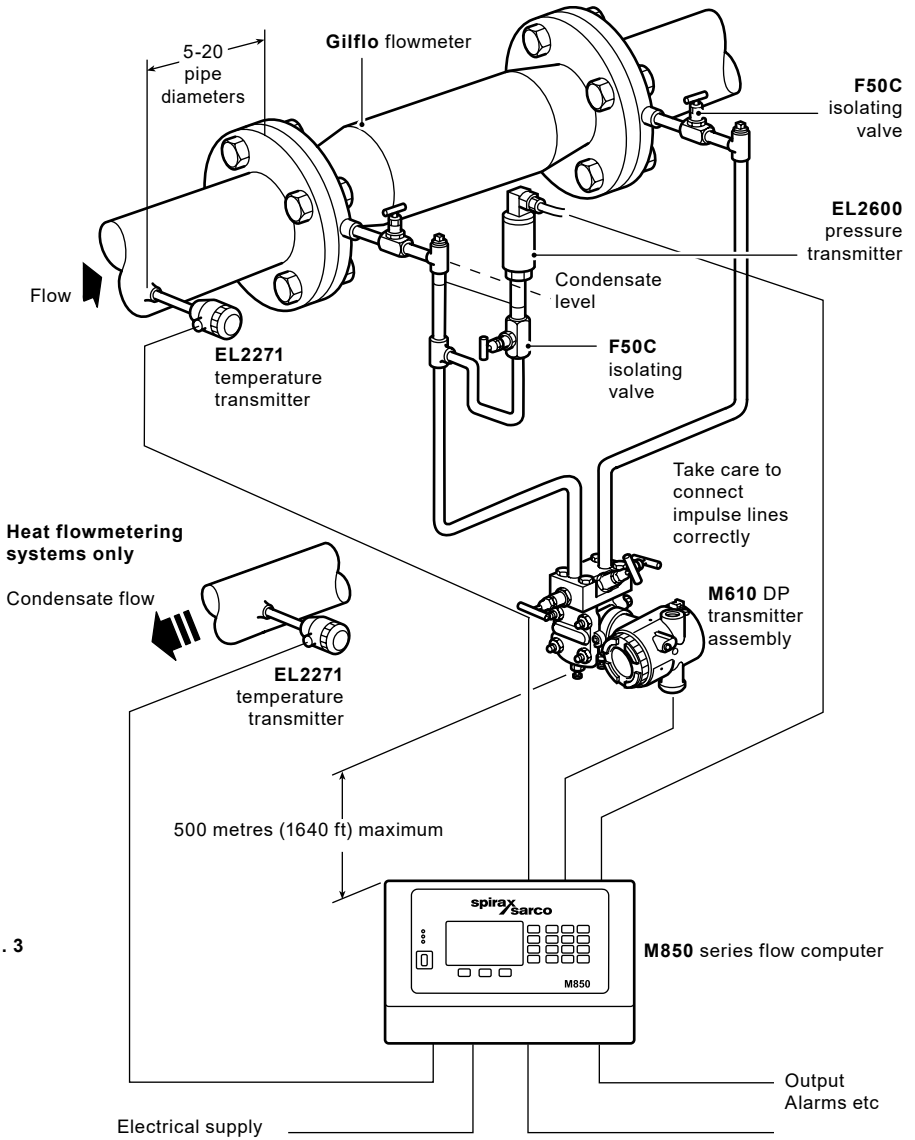

Fig. 3

Installation points to watch:-

1. Ensure all pipework is adequately supported and properly aligned.
2. The minimum recommended lengths of straight pipe are 6 D upstream and 3 D downstream.
3. Take care to ensure the correct direction of flow as indicated by the arrow on the flowmeter body.
4. Take precautions to avoid reverse flow through the flowmeter.
5. Avoid installing the flowmeter downstream of a pressure reducing valve as this may cause inaccuracies and/or possibly damage. Similarly, avoid installing the flowmeter downstream of a partially open valve.
6. Remember that actuated valves may cause rapid pressure fluctuations which could cause damage.
7. Adequate line drainage should be provided upstream of the flowmeter for all steam applications.
8. Please read Section 9 before wiring the system.

4.4 Gilflo installation for gases

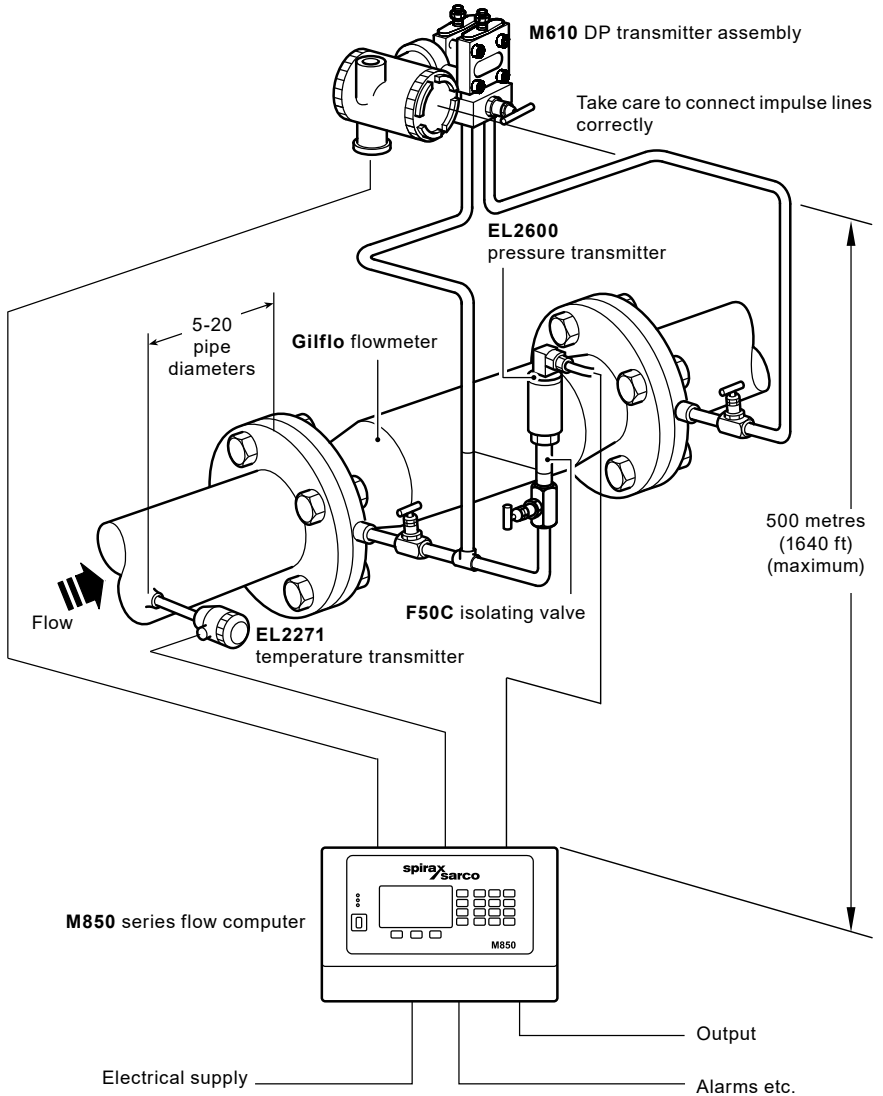

Fig. 4

Installation points to watch:-

1. Ensure all pipework is adequately supported and properly aligned.
2. The minimum recommended lengths of straight pipe are 6 D upstream and 3 D downstream.
3. Take care to ensure the correct direction of flow as indicated by the arrow on the flowmeter body.
4. Take precautions to avoid reverse flow through the flowmeter.
5. Avoid installing the flowmeter downstream of a pressure reducing valve as this may cause inaccuracies and/or possibly damage. Similarly, avoid installing the flowmeter downstream of a partially open valve.
6. Remember that actuated valves may cause rapid pressure fluctuations which could cause some damage.
7. Take care not to exceed temperature limitation for pressure and temperature transmitters.
8. Please read Section 9 before wiring the system.

4.5 ILVA installation for steam

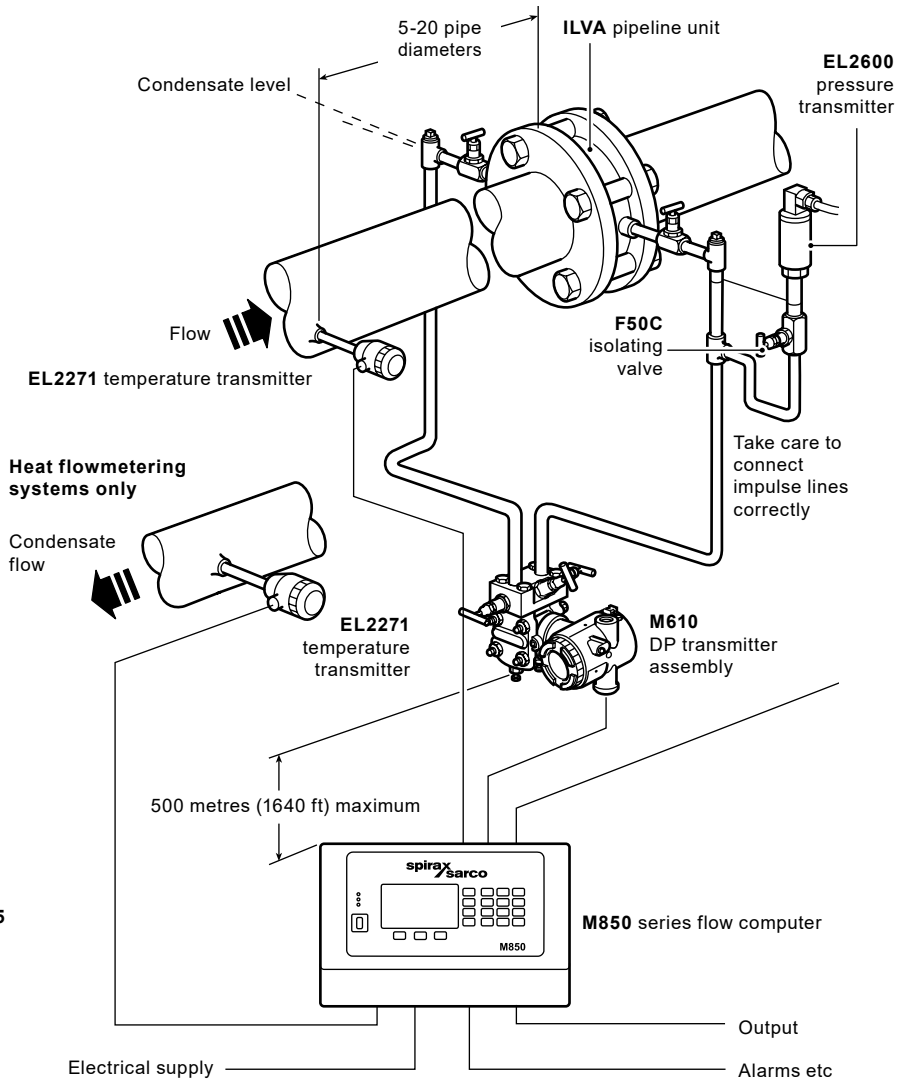

Fig. 5

Installation points to watch:-

1. Ensure all pipework is adequately supported and properly aligned.
2. The minimum recommended lengths of straight pipe are 6 D upstream and 3 D downstream.
3. Take care to ensure the correct direction of flow as indicated by the arrow on the flowmeter body.
4. Take precautions to avoid reverse flow through the flowmeter.
5. Avoid installing the flowmeter downstream of a pressure reducing valve as this may cause inaccuracies and/or possibly damage. Similarly, avoid installing the flowmeter downstream of a partially open valve.
6. Remember that actuated valves may cause rapid pressure fluctuations which could cause damage.
7. Adequate line drainage should be provided upstream of the flowmeter for all steam applications.
8. Please read Section 9 before wiring the system.

4.6 ILVA installation for gases

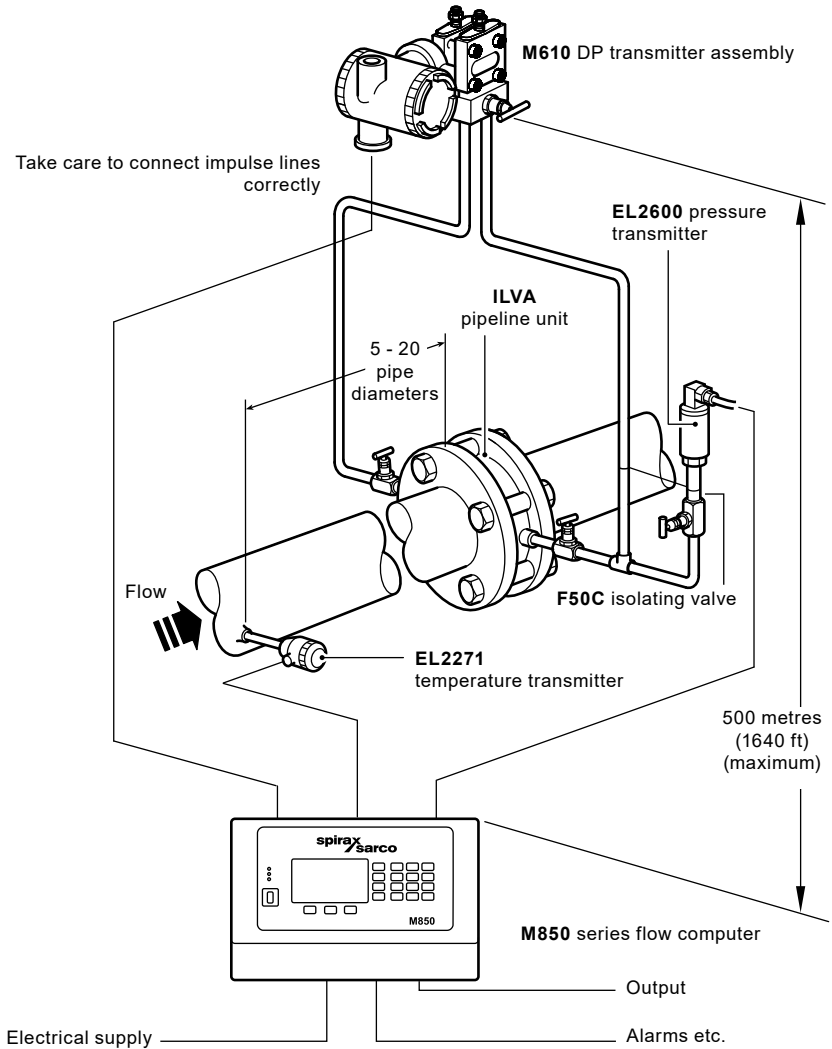

Fig. 6

Installation points to watch:-

1. Ensure all pipework is adequately supported and properly aligned.
2. The minimum recommended lengths of straight pipe are 6 D upstream and 3 D downstream.
3. Take care to ensure the correct direction of flow as indicated by the arrow on the flowmeter body.
4. Take precautions to avoid reverse flow through the flowmeter.
5. Avoid installing the flowmeter downstream of a pressure reducing valve as this may cause inaccuracies and/or possibly damage. Similarly, avoid installing the flowmeter downstream of a partially open valve.
6. Remember that actuated valves may cause rapid pressure fluctuations which could cause some damage.
7. Take care not to exceed temperature limitation for pressure and temperature transmitters.
8. Please read Section 9 before wiring the system.

5. Product familiarisation

5.1 Front panel

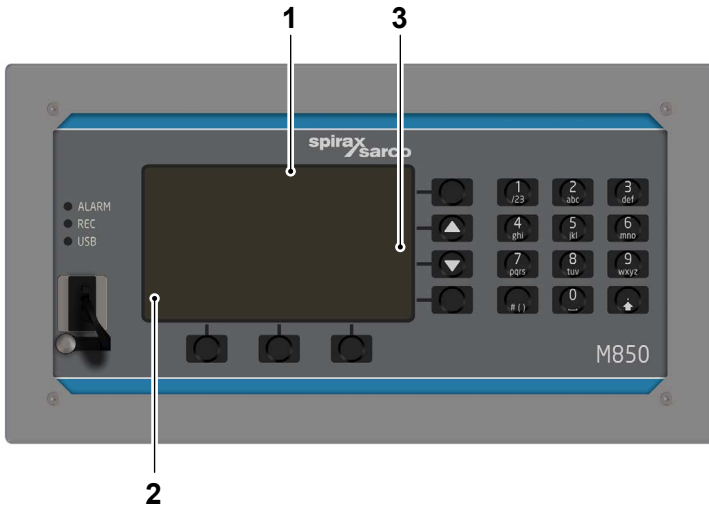

5.1.1 Display organisation

The display along with buttons is a basic interface between the device and a user. It displays following information:

- Results of measurements
- Messages.
- Archive menu.
- Settings menu.
- Pictograms of the function buttons (keypad).

Display can be divided into three main areas:

1. Area of results (1)
2. Area of pictograms of three lower function buttons (2)
3. Area of pictograms of four side function bottom (3)

5.1.2 Function buttons

There is 7 function buttons located on the front panel of the M850 device and 12 number buttons. Each function button can perform different actions depending on an operational state of the flow computer and information displayed on the screen. To simplify a handling of the device, on the screen are displayed pictograms which symbolize buttons functions active at the moment.

5.1.3 LED indication

On a front panel are located three LEDs (6) marked as:

- ALARM – when the device is in an alarm state it lights up in **red** (constantly or blinking), it is accompanied by a message explaining the cause of the alarm,
- REC – constant **green** light indicates recording data into an internal memory, pulsing **green** light indicates opening/closing a file, **red** color indicates an error in the archive function.
- USB – it lights up in **orange** when USB controller is on, **green-orange** flashing indicates reading/recording data, **red** light indicates an error (e.g. lack of USB flash drive during reading/writing data).

5.1.4 USB port

The port is adapted to operate only with USB flash drives. It allows to transfer data between a flow computer and USB flash drive. The device does not support advanced structures of directories and subdirectories, which can be stored in an external USB flash drive. We recommend using a flash drive dedicated to work with the flow computers.

5.1.4.1 Writing data to flash drive

Data which can be transferred from the device:

- archive of the process (current) values,
- archive of hourly archived totalisers and average/minimum/maximum of process values,
- event log, authorisation log and set-up log,
- the device current settings (see Section 10.18).

To copy files to USB flash drive, go to  → **Main menu** → **Copy files**. Selecting **Current archives** copies the main archive file, the totalisers archive file, the event log file and the authorisation log file. Selecting **Choose file** allows the user to select the files to be copied (see the table below). Copying the files can be available only for selected users and may require the password.

Files can also be transferred (with simultaneous removal of copying file) or deleted, but in case of some files, these functions are only available to the user SERVICE.

List of file names:

File Name	File Type
ar[addr]_[count].txt	Main Archive file
artot[addr].txt	Hourly Archive file
a_log_[addr].txt	Authorisation log file
event_[addr].txt	Event log file
s_log.dat	Settings log file

where [addr] is the two-digit address of the device in the RS-485 network, and [count] is the successive number of the created archive file.



When using few devices in the plant, it is recommended to configure different addresses even when the RS-485 transmission is not used.

5.1.4.2 Loading data from flash drive

Data which can be transferred (entered) to the device:

- Characteristics of a liquid medium other than water (see Section 10.4.1.3. Other liquid media),
- Characteristics of the non-linear transmitter (see Section 10.8.6),
- Set of device settings saved in a file (see Section 10.18),
- Firmware upgrades (see Section 11.3).



M850 device does not support advanced structures of directories and subdirectories, which can be stored in an external USB flash drive. We recommend using a USB flash drive dedicated only to work with the flow computers.



Removal of the USB flash drive from USB port when the USB LED is on (lights in **orange** or **green-orange**), may result in losing all the data stored in the flash drive.

5.2 Process values layout in A, B, C, X, Y and Z application

The M850 devices perform measurements and calculations according to their configuration. Each measurement or calculation value has its own symbol and belongs to one of the applications. In the device there are six applications (measuring systems) A, B, C, and auxiliary applications X, Y and Z. Applications X, Y, Z is used for calculation values or auxiliary measurements, whilst A, B, C are used for main flow calculations.

Applications A, B, C are designated to group process values of separate measurement application of the installation. Each main application is determined with help of wizard and all necessary process values are loaded automatically.

Auxiliary values can also be loaded to the systems – measured values (if any measurement inputs were left) and calculated values (defined by formulas) - a total of up to 8. Each such auxiliary value can be entered to any system A to Z. It is recommended to load into systems A, B, C values linked with the given main application (e.g. water level or calculated efficiency) whereas other values (e.g. sum of heat flowrates of all main applications) – into systems X, Y, Z.

5.2.1 Process values symbols

Auxiliary values may be given any symbols consisting of one or two letters. Values loaded automatically into applications A, B and C have symbols assigned by the device. These symbols have the following meaning:

- P Heat flowrate or difference of heat flowrates between supply and return.
- q Volumetric flow of gas in normalised units (volume referred to reference conditions).
- q_m Mass flow.
- q_v Volumetric flow.
- p Measured pressure.
- p_c Saturated steam or boiling water pressure determined theoretically based on measured temperature.
- T Measured temperature.
- T_c Saturated steam or boiling water temperature determined theoretically based on measured pressure.
- ρ Medium density.
- h Medium enthalpy.
- Δp Pressure difference at the orifice in differential pressure device.
- ΔT Temperature difference between supply and return.
- k Thermal coefficient of water.

To the list from the previous page, symbols a block letter in the upper index can be added which means:

- Kind of medium to which this quantity refers (D - steam, W - water, G - gas, other letters may be used for other liquid media) or
- S - supply, R - return, if there is the same medium in both pipelines of main application.

If a process value does not refer strictly to one pipeline but to main application as a whole (e.g. difference of heat flowrates between supply and return, mass flow in closed system or common pressure in both pipelines), then this mark in the upper index is not added.

Examples of values symbols:

Steam – condensate closed system

- P^D Steam heat flowrate (refers only to steam – D in upper index).
- P^W Condensate heat flowrate (refers only to condensate – W in upper index).
- P Difference of heat flowrates between steam and condensate (no mark in upper symbol because this quantity is relevant to the system as a whole and not to a given pipeline).
- q_m Mass flow of both steam or condensate (no mark in upper symbol because this quantity is common to both pipelines of main application).

Water – water system

- T_s Supply temperature (letter S in the upper index means that this quantity refers only to the supply pipeline; letter W would have no sense because water flows in both pipelines).
- T_R Return temperature (letter R in the upper index means that this quantity refers only to the return pipeline).
- ΔT Temperature difference between supply and return (no mark in upper symbol because this quantity is relevant to the system as a whole and not to a given pipeline).
- p Common pressure in supply and return (no mark in upper symbol because this quantity is common to both pipelines of main application).

Groups of values for all types of measurement in different applications with their explanation are given in Section 10.4.3.

Symbols may be displayed in abridged form (as above) or in full form i.e. with added information about application to which they belong, e.g.:

- A.P^D Full form, heat flow rate of steam in application A.
- P^D Abridged form.

Abridged form is used exclusively where it can be learned from context to which system the value belongs – e.g. on common screen (on the left at the figure below) where the application symbol is printed in title above the table. However on individual screen full form is used.

Both individual values and whole applications can be given text description – tags, as a one text line. The tag is displayed together with a symbol wherever it is possible. In examples above system A was given the tag 'Steam-condensate' and A.q_m – 'Mass flowrate'.

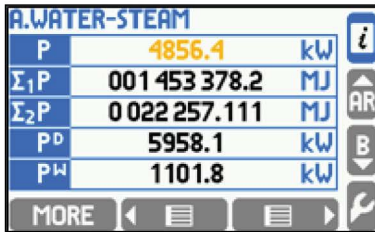

5.2.2 Totalisers symbols

Except of process values described above (of the last second) the device can display also statuses of heat energy and flow totalisers. For each value which is heat or flow rate, up to four totalisers marked as Σ₁, Σ₂, Σ_H and Σ_L can be used. For more details see Section 10.10. Totalisers symbols are as follows:

- A.Σ₁P^D Full form, main totaliser of steam heat energy in application A.
- Σ₁P^D Abridged form.
- B.Σ₂q_m Full form, additional totaliser of steam mass flow in application B.
- Σ₂q_m Abridged form.

5.2.3 Process values assigned to the same transmitter

In some industrial installations two (or more) different process values may be assigned to the same measuring input i.e. physically to the same measuring transmitter. For more details see Section 10.8.1.

Example:

Hot water flows through two heat exchangers in sequence and measurement of heat energy at each of exchangers was implemented in applications A (first exchanger) and B (second exchanger). Temperature at the outlet of the first exchanger is then equal (or rather assumed to be equal) to temperature at the second exchanger inlet. Therefore only one temperature transmitter can be used and two values can be assigned to it:

- A.TR return temperature in system A (temperature at the first exchanger outlet).
- B.TS supply temperature in system B (temperature at the second exchanger inlet).





Though both values given above are assigned to the same transmitter and always indicate the same value, they are treated by device as independent. Each may have its own caption, own alarm and control thresholds, can be separately archived etc.

5.3 Screens navigation





Information on all values and totalisers is organised in form of screens. Navigation between screens is performed using buttons or may be switched to automatic mode. While commissioning user should configure screens sets with all required process values. To simplified readout not used or not necessary data presentation should be deactivated. Display mode configuration was described in Section 10.16.

5.3.1 Main and additional screens





Basic information is displayed in form of main screens and additional screens. Navigation between them is performed using vertical cursors (two central buttons on the right side: s and t).

Main screens contain up to 4 tables for every application A, B, C, X, Y and Z. Up to 5 or 3 process values and totalisers can be set into every table depending on the letter size. Navigation between tables within application is performed using horizontal cursors (button   and  ).

B.Steam		
P ^D	1339.8	kW
Q _m ^D	1.523	t/h
Σ ₁ P ^D	000 746 958.5 MJ	

MORE    

B.Steam		
T ^D	371.6	°C
p ^D	2.987	MPa a
ρ ^D	10.5	kg/m ³
T ^D	371.6	°C
Δp ^D	2.5	kPa

MORE    

X.Total heat		
P	95.2	kW
Σ ₁ P	000 000 045.7 MJ	
Σ ₂ P	00 000 004.09 MJ	

MORE 

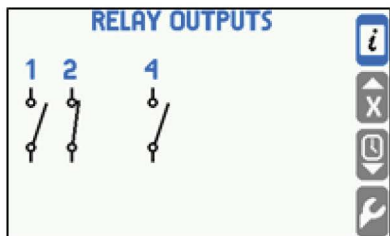



DATE AND TIME	
Mo 16	2015-02-18 12:16:06
Tu 17	
We 18	
Th 19	
Fr 20	
Sa 21	
Su 22	

ADJUST Standard (winter) 

MAIN ARCHIVE	
File ar01_021.txt	
Status	15 s
• REC	3 s
The successive file: ⇒ 2011-04-27 00:00	

MORE MENU || STOP 

Additional screens are: relay outputs screen, date and time screen and main archive screen. Relay outputs screen informs about status of relays (closed or open, relays not used are not displayed). On date and time screen button **ADJUST** enables setting the clock and calendar. Main archive screen displays information about status of archiving. Bottom buttons enable to control archiving (archive operation is described in Section 5.8).

Longer pressing (more than 1 sec.) one of the buttons  and  on any of the main screen will start the automatic scrolling of all tables of currently displaying application. When vertical cursor is kept pressed - automatic scrolling of all tables of all applications starts. Pressing any button interrupts automatic scrolling. It is also possible to configure the scrolling function to display only selected tables.

5.3.2 Detailed screens

Pressing button **MORE** while displaying the main screen (table) switches over detailed screens of process values within the application. Detailed screens show always only one process value with some additional information. With some exceptions detailed screens can preset data in various ways:

- **Large digits** – value printed with a capital letter.
- **Trend graph** – last 140 values in form of a graphic diagram.
- **Bargraph** – value in form of analog bargraph.
- **Totalisers 1, 2** – value of main ($\Sigma 1$) and additional ($\Sigma 2$) totalisers.
- **Totalisers H, L** – values of overflow and underflow totalisers (ΣH and ΣL).
- **Min, max** – minimum, maximum and average values.
- **Min, max (bar)** – minimum, maximum and average values in form of bargraph.

Density(ρ), enthalpy(h), pressure difference (Δp) and water thermal coefficient (k) may be displayed only in form of **Large digits**. Screens **Totalisers 1, 2** and **Totalisers H, L** are available for values with active totalisers. A screen with all activated alarm and control thresholds for application is displayed as a detailed screen.

Example:

Screens below: Large digits; Bar graph; Totalisers H, L; Trend graph; Totalisers 1, 2; Min, max; Min, max (bar); Alarm and Control thresholds.

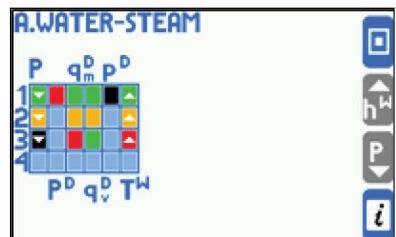
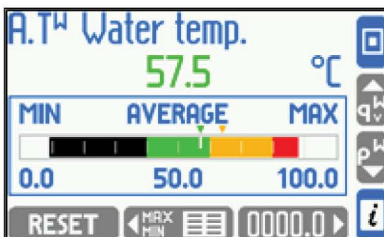
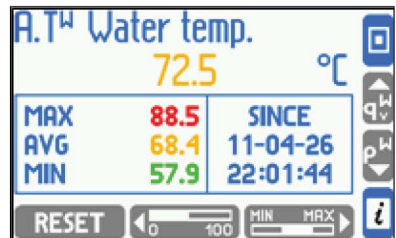
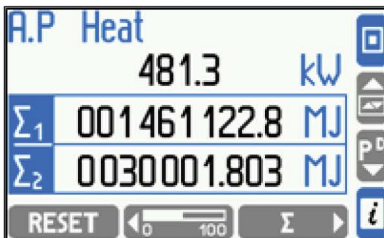
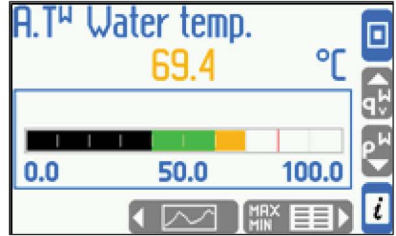

Range of bargraph and trend diagram can be set separately for every value. Range of horizontal and vertical axis of **Trend graph** are displayed after pressing button .



Navigation between various process values is executed with vertical cursors, while navigation between various data presentation of the same value – with horizontal cursors.

Longer pressing the vertical cursor starts automatic scrolling. Pressing  always return to the main screen.

The left bottom button on some detailed screens serves some special functions:

- **ARCHIVE** on **Trend graph screen** starts an archive browser if the value is archived (see Section 5.10),
- **RESET** on screens **Totalisers 1, 2** and **Totalisers H, L** allows to reset resettable totalisers,
- **RESET** on **Min, max** and **Min, max (bar)** screens allows to reset and begin monitoring minimum, maximum and average values.

Before resetting totalisers or minimum, maximum and average values the device requires choosing the option and confirmation, as on the figure below.

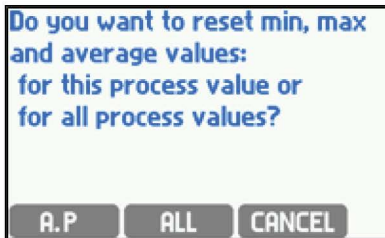
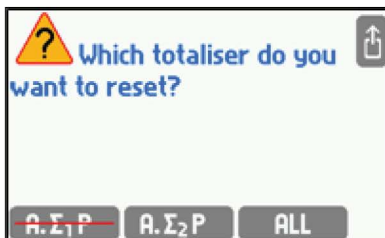



By pressing **ALL** button, all active resettable totalisers are simultaneously reset in all applications. Similarly **ALL** button starts monitoring of minimum, maximum and average values from the beginning for all values in all applications. Totalisers other than resettable (see Section 10.10) cannot be reset in this way (symbols of such totalisers are marked of).

5.3.3 General information on status of all applications

The  button available on all screens with process values displays a screen with short informing about status of main and auxiliary applications, and about firmware version and the network address of the device.

RS-485: 01	
IP:	192.168.2.205 : 502
Measurement status:	
A: OK	X: - -
B: OK	Y: off
C: -W-	Z: off



5.4 Main menu

All functions are accessed in **Main menu** except the overview of results and some actions described in Section 5.3.2. Main menu can be entered from every main screen and additional screen with button . Main menu cannot be entered from detailed screens, first one user have to return to the main screen by pressing  button.

Basic contents of main menu:

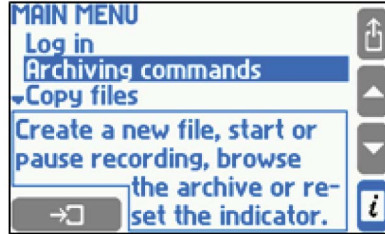
- Log in
- Archiving commands
- Copy files
- Settings
- Load or save settings
- Media manager
- Characteristic manager
- RS-485 monitor
- Change the language



Required menu item should be selected with the vertical cursor, then selected with the enter button . To quit main menu user should choose button .

Log in is performed to access the features that require authorisation (password protected). After logging into the main menu there are displayed additional items. Information on the authorised operations are located in Section 5.7.

Archiving commands allows to establish a new main archive file and hourly archive file, it allows to start, stop, resume recording, use an archive browser. Menu of archive commands can be entered directly from archive screen with  button. Archiving was described in Section 5.9.

Copy files: the process values archives, the totalisers archive, the average values archive and the log files (for more information see Section 5.1.4.1. Writing data to flash drive).

Settings enable to configure the device. All settings can be viewed and changed in a hierarchical menu. Principles of moving around the settings, editing them, and the importance of the various settings are described together with relating to them functions, in Section 5.3.

Load or save settings allows to load and save the settings from/to a memory device (for more information see Section 10.18).

Media manager enables the flow computer to work with any liquid media, while **Characteristic manager** enables to work with any non-linear transmitter. This requires the appropriate characteristics of the liquid medium (see in Section 10.4.1.3. Other liquid media) or the characteristics of the transmitter (see in Section 10.8.6). This information is stored in the media manager and the characteristic manager.

RS-485 monitor is a service purpose function. Every query and response on RS-485 lines is monitored with blinking of ALARM LED on front panel.

Change the language allows the preferable language to be chosen from a list. There are six languages: English, German, French, Polish, Spanish or Portuguese.

5.5 Communication with the master system

5.5.1 RS-485 port

When using the RS-485 port it is possible to read:

- Process values (ASCII i Modbus RTU).
- Process values archive (only the last file, ASCII i Modbus RTU).
- Last 500 events recorded by the flow computer (ASCII only).
- Last 500 authorised activities registered by the device (ASCII only).
- Totalisers files, the event log and the authorisation log (ASCII only).
- Information about the current results archive and its status (ASCII and Modbus RTU).
- Archiving status (start, stop etc., ASCII only).
- A GSM module can be connected to the RS-485 port, which enables the transfer, in the form of an SMS text message, information about selected alarms and failures when they occur, measurement values and totalisers. The list of process values to be sent is configured individually.

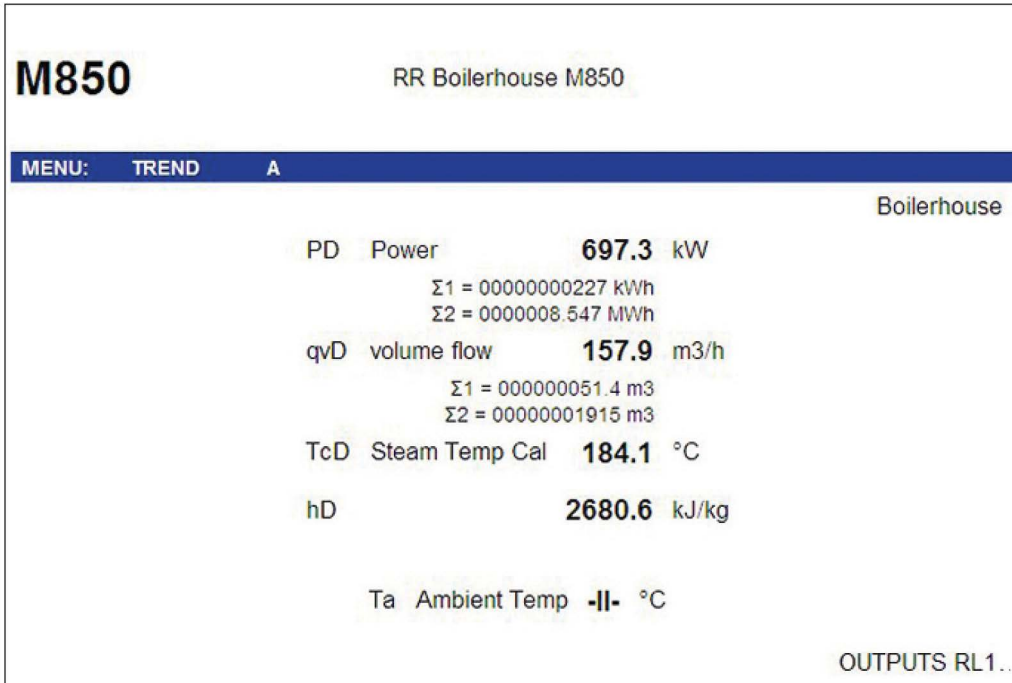

5.5.2 Ethernet port

It is possible to connect the device to LAN and read information remotely, using the Ethernet port and a web server. To do this user must enter the IP address of the device in the settings (IP configuration in the device:

 → **Main menu** → **Settings** → **Ethernet port**).

The web server allows you to:

- Read remotely all measurement channels (including the additional measurements and calculated values).
- Read the totalisers (states of configured totalisers are displayed below the process value).
- Check the output relay status (OUTPUTS RL 1..4), a black dot indicates a short circuit (closing) of the relay, a grey dot an open state).



The network connection has been tested in: Internet Explorer 8, Opera, Mozilla Firefox, Chrome and Safari browsers. Java runtime environment must be installed to display charts correctly.

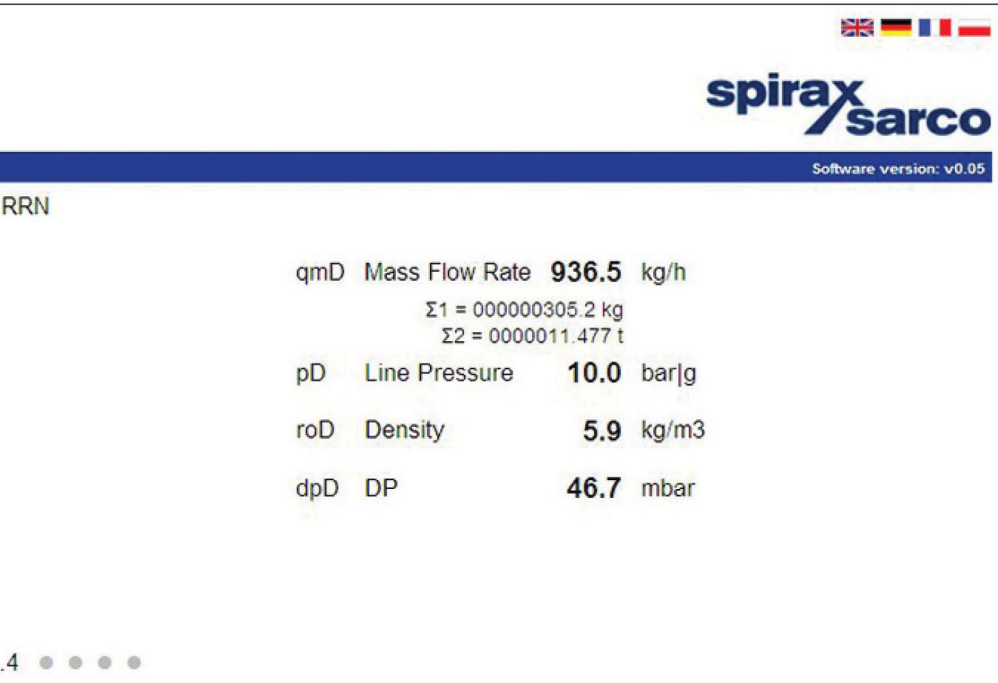

The screenshot shows the web interface for a Spirax Sarco device. At the top right, there are flags for the UK, Germany, France, and Italy. The logo 'spirax sarco' is prominently displayed. Below the logo, it says 'Software version: v0.05'. The main display area shows the following data:

RRN	qmD	Mass Flow Rate	936.5	kg/h
		$\Sigma 1 =$	000000305.2	kg
		$\Sigma 2 =$	0000011.477	t
	pD	Line Pressure	10.0	bar g
	roD	Density	5.9	kg/m ³
	dpD	DP	46.7	mbar

At the bottom left, there are four small grey circles, with the first one partially filled, and the number '4' is visible to the left of the first circle.

5.6 Messages

There are many messages that might be activated by the application. Messages are confirmed by pressing the **OK** button. Messages do not suspend the measurements except for emergency states.

5.7 authorised functions, user login and logout

Some functions can be password protected. Each function can be individually blocked or allowed for different device users. 25 users can be defined, each with its own password. The master user is an administrator (ADMIN), who has the entitlements to any activities excluding SERVICE operations.

ADMIN decide which function will be password protected for all users by selecting:

☑ → **Main menu** → **Administrative data** → **Protected commands**

Execution of protected function is possible in two ways:

- Each time after calling protected function by giving username and password.
- The user first logs in by entering username and password, which is signaled by pictogram on display. Then user can perform all protected functions, (to which he has the entitlements) without needing to type a password for each operation. After finished configuration user must logout. In case of forgetting to logout, device will do this automatically after a preset time (30 s, 1, 2, 3, 5 or 10 minutes).

User login:

After selecting **☑** button, in **Main menu** select **Log in**, then specify the user name and enter the password. Password consists of 3 to 6 digits from 1 to 9 (without 0). To enter password combination, use the buttons at the bottom of the front panel, each digit requires a double press of a button. For example, to select the number 4 first selects a group of three digits **4,5,6**, then the button labeled **4**. To logout, in **Main menu** select **Log out**.

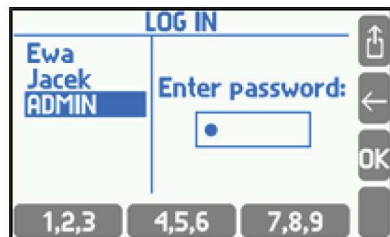

After logging into the main menu option **Log in** turns automatically into **Log out** and some additional items appear. The main menu is then as follows:

Logged-in user:

Log out
 Archiving commands
 Copy files
 Settings
 Load or save settings
 Audit trail
 Media manager
 Characteristic manager
 Change password
 RS-485 monitor
 Change the language

Logged-in ADMIN:

Log out
 Archiving commands
 Copy files
 Settings
 Load or save settings
 Audit trail
 Media manager
 Characteristic manager
 Change password
 Administrative data
 Test inputs and outputs
 RS-485 monitor
 Firmware and licences
 Restore factory settings
 Change the language

Only the administrator can define a protected activity, add new or delete existing users. ADMIN can also change user's password without its knowledge. The user can change only its own password.

Commands that can be password protected after proper programming:

- Archiving commands (creating a new file, starting and pausing recording, clearing indicator).
- Copy files (copying and removing files from the internal memory with the exception of the files that can be removed/transferred only by SERVICE).
- Resetting min, max (resetting tracing minimum, maximum and average value).
- Adjusting date/time.
- Resetting totalisers (the resettable ones).
- Main settings (changing any settings except those three mentioned below).
- Threshold settings (changing the levels and hysteresis of alarm and control thresholds).
- Screen settings (configuring screens and changing display settings).
- Archiving settings (changing archive-related settings e.g. selecting recorded items).

The administrator decides which of the above actions require authorisation and which users are allowed to perform them. If no user is given permission to the activity, the only legitimate is an administrator.

Features available only for the administrator (always password protected – see Section 11):

- Administrative data (choosing password-protected commands, define users, their passwords and entitlements, for more information see Section 11.2).
- Audit trials – browsing on the device screen (see Section 5.16).
- Test of inputs and outputs (see Section 11.5).
- Firmware and licenses (installing new firmware and granting licenses, see Section 11.3).
- Restoring factory settings (see Section 11.4).
- Change the language.

Features available only for the SERVICE (ADMIN with service password):

- Calibration of measuring inputs.
- Deleting/moving the event log, authorisation log and calibration log.

	<p>The administrator password (the user ADMIN) in new devices is: 1. This password should be changed by an administrator to another soon after programming the device. SERVICE password is reserved for Spirax Sarco authorised service.</p>
--	--

5.7.1 Changing password by the user/administrator

Each user can change their own password. For this purpose, after login, in the **Main menu**, select the **Change password** option, and then enter a new password twice. Changing the administrator password is similar.

5.7.2 Retrieving forgotten passwords and obtaining service password

If a wrong password is entered by a user or an administrator during logging or authorisation one of the following messages is displayed:

If a wrong password was entered by mistake press **RETRY** button and reenter the correct one.

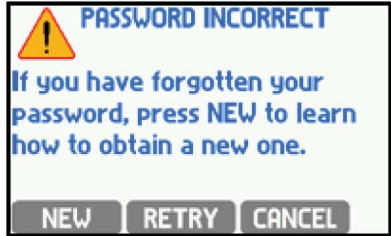
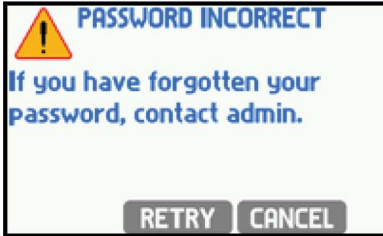

If user forgot his password, the administrator can change it without knowing the forgotten password. However if administrator forgot his password he must contact the factory service. On screen, which is displayed after entering an incorrect password, press **NEW** button - a code will be displayed with which the manufacturer can generate a new password for the administrator.

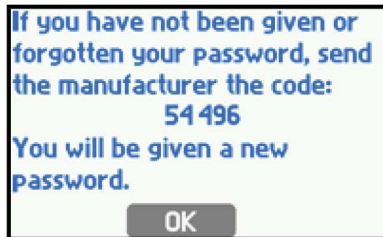

5.7.3 Adding users and granting entitlements by the ADMIN

In the **Main menu** → **Administrative data** an administrator defines users and gives them entitlements, by selecting groups of features that the user will be able to perform after entering a password. After creating a new user, the device generates a numerical password. The device does not allow overly simple passwords (e.g. 11111). Each user has separately-defined entitlements. Available to select are only those activities that previously had been declared as password-protected. In this menu, the administrator can also change a user name, a user password or remove a user.

Users and entitlements submenu opens a list of users and table of their entitlements.

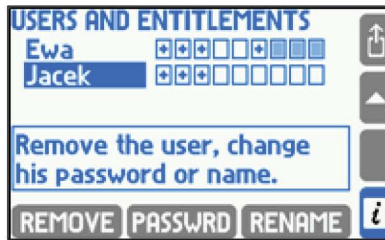
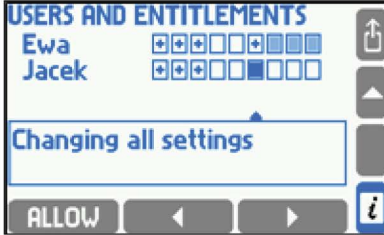

Table rows correspond to users and columns to respective commands. Only commands which require authorisation are displayed. In a frame under the table there is a command name corresponding to the column pointed with the cursor. Symbol + in the square means that the user is allowed for execution of a given command. To allow or forbid entitlement user have to point with a cursor the proper square and press the **ALLOW** or **FORBID** button. If a user is authorised to change main settings then automatically is also authorised for the remaining settings groups – then these squares are shadowed.

To add a new user the administrator has to place the cursor on the users list and press **NEW ONE**. After pressing **MENU** button, the bottom buttons change their function and enable to remove the user (**REMOVE**), to change the password (**PASSWRD**) and the user name (**RENAME**).

5.8 Archive screen

The information about archiving status is displayed on archive screen.



The archive file name is displayed at the top. The archive status is displayed at the bottom.

- NO FILE** There is no current archive file.
- STOP** The current archive file is in the internal memory but recording is stopped.
- REC** Data is being recorded.
- FULL** Archiving has been stopped due to the maximum file size or lack of free space in the memory.

On the right there are displayed the first (higher) and the second (lower) recording speed. The actual speed is highlighted. Below there is a memory space usage indicator and expected date and time when the card space will be filled up. Usage forecast is always computed for the actual recording speed under the assumption that recording will be active all the time.

If the archive is set to overwrite mode the usage indicator may be reset. For this purpose **Reset usage indicator** command is used. It does not remove any records. After resetting indicator takes into account only these records which have been added to the archive since its resetting.

MORE button allows access to additional information: number of records in the archive, date and time of the youngest and the oldest record, date and time of usage indicator resetting as well as number of records saved since that time. If the indicator has not been cleared, then the date and time of the reset is assumed as the time of the file creation.

5.9 Archiving control of the current results

The device has a 2 GB internal memory, which is almost entirely allocated for the purpose of archiving results. The archiving control can be done at two locations in the menu:

- Additional screen **MAIN ARCHIVE**.
-  → **Main menu** → **Archiving commands**.

ARCHIVING COMMANDS menu includes:

- Stop/Resume recording of the results.
- New file – setting up a new Main Archive file.
- Reset usage indicator – memory full indicator.
- Browse archived results on the device screen.



5.9.1 Creating a new Main Archive file

Creating a new data set for archiving can be done from two locations: the additional screen **MAIN ARCHIVE** or  → **Main menu** → **Archiving commands**.

On the **MAIN ARCHIVE** screen select **MENU** → **New file** → . To the question: 'Do you want to create a new Main Archive file?' Confirm with the button **YES**.

After accepting the REC LED blinks **green** for a few seconds. In the internal memory of the device the text file is created: ar[addr]_[count].txt. The addr is a two-digit address of the device, and the count is the serial number of created file (in one instrument it is impossible to create two archive files with identical name). An example of the file name: ar01_004.txt.



To distinguish between files from different devices is recommended to configure different addresses even when the RS-485 transmission is not used.

Then the message appears that the new archive has been created along with the estimated time of filling the internal memory, and question 'Do you want to START RECORDING ?'.

To start archiving to the newly created file press button **YES**.

Function of creating a new archive can be password protected. User with entitlement to **Archiving commands** may not have permission to delete archived files.

Similarly, creation of the new archive file by pressing button  → **Main menu** → **Archiving commands** → **New file**.

5.9.2 Starting, resuming and stopping archiving

The most convenient way to start or stop the archiving process is using the **MAIN ARCHIVE** screen. When archiving is stopped the quick start button **• REC** is available. If archiving is on, the same button takes the form of **|| STOP**, and stops data archiving. After stopping, user can resume recording by pressing the button **• REC**, and the results are appended to the current file existing in the internal memory. Starting or stopping recording requires double confirmation. These functions can also be password protected.

Both functions can be also activated from the **MAIN ARCHIVE** screen: **MENU** → **Resume/Stop recording** and from **Main menu**: **☞** → **Archiving commands** → **Resume/Stop recording**.

5.9.3 Memory usage indicator

The **MAIN ARCHIVE** screen provides information about percentage of data occupancy in the internal memory and the expected date and time of filling. This is only estimated time. In particular, when working with two recording speeds (for example, dependent on exceedances of alarm and control thresholds), this information may significantly fluctuate.

In the Successive files archive mode, if a day/week/month limitation is selected, instead of the predictions device shows actual date and time of the next file creation.

In archive mode Overwrite, archive indicator can be reset. Using this, a user can marks the date and time when archive was read last time. Then the indicator means overwriting the results from the last reading. Resetting indicator index can be performed from the **MAIN ARCHIVE** screen: **MENU** → **Reset usage indicator** or from **Main menu**: **☞** → **Archiving commands** → **Reset usage indicator**.

5.10 Browsing the archived measurement results

The results of measurements stored in the device's memory can be viewed on the display in the table or in graphical form. This feature is rather a preview. Advanced analysis of the results should be done on the computer using dedicated software, where the possibilities are much more extended.

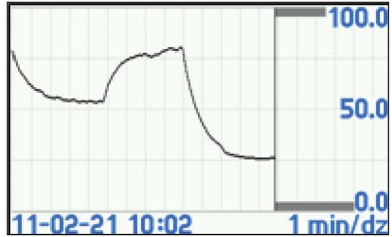
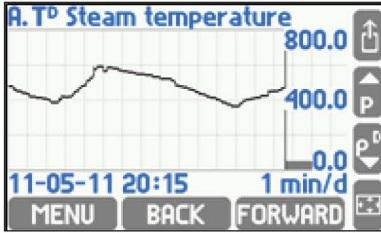

To enter results browser select: → **Main menu** → **Archiving commands** → **Browse**
 or from detailed screen Trend graph with the button **ARCHIVE** or from the additional MAIN ARCHIVE screen with the button: **MENU**.

Using the buttons **BACK** and **FORWARD** archive can be browse in time axis, and the buttons '▲' and '▼' can be changed subsequent archived results for the selected time interval.

A. T° Steam temperature	
11-05-11 20:15:00	480.5
11-05-11 20:15:03	480.5
11-05-11 20:15:06	480.5
11-05-11 20:15:09	480.4
11-05-11 20:15:12	480.5
11-05-11 20:15:15	464.5

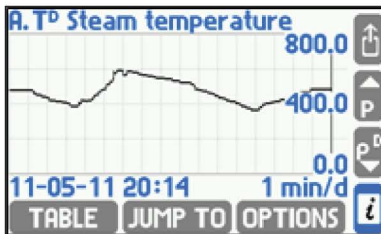



A. T° Steam temperature	
11-05-11 20:14:45	480.5
11-05-11 20:14:48	480.5
11-05-11 20:14:51	480.5
11-05-11 20:14:54	480.5
11-05-11 20:14:57	480.5
11-05-11 20:15:00	480.5

The scope of the presented time interval is dependent on the frequency of archived results (influenced by both of the frequency I and II) and cannot be changed while viewing.

Selected scope can be enlarged to full screen with the button  (to return to the original size press any button).



After pressing the button  additional browsing functions are available:

 - Searching the course of a specified date and time;

 - Presenting results in a table;

 - Following options:

- **Autoscaling** – automatic scaling of the y-axis plot, when values are out of defined range,
- **Substituted values** – show the assumed values during measurement failure (substituted measured values of the sensor while failure is detected, the correct function must also be enabled in the settings of measuring inputs),
- **Large chart legend** – axis scale in full screen mode ().

5.11 Totaliser archive

Totalisers value are recorded in the Hourly Archive file which is created automatically if at least one totaliser or process value is declared for registration. There is always only one Hourly Archive file even if settings were changed. When changes are completed only a new header is recorded to a file. When the file is deleted or moved from the internal memory, the device automatically creates a new one.

The name of totaliser archive file is artot[addr].txt, where addr is a double-digit device address. The file can be copied or moved to an external USB memory device, and then transferred to a computer (see Section 5.1.4.1 - Writing data to flash drive). The data in the file are secured with control fields, that allow to determine whether they have been modified outside of the instrument.



To distinguish between files from different devices is recommended to configure different addresses even when the RS-485 transmission is not used.

5.12 Alarms and control

Up to four alarm and control thresholds can be set for most process values (exceptions - see Section 10.9). Each threshold has the individually adjustable level of activation, hysteresis, 'High' or 'Low' mode and can activate the alarm function and/or the control function. Every threshold can be assigned also with a screen colour (green, yellow, red). When more thresholds are overruled the result colour is changed to a colour of the higher threshold.

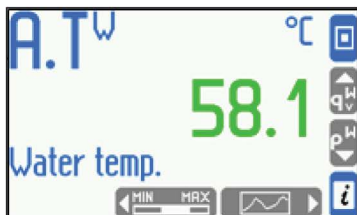

Alarm functions:

- Exceedances reporting – on the front panel the ALARM LED starts blinking in **red**, on the screen is displayed a message about the channel number and the date and time of the exceedance. If more exceedances are reported, the messages are queued. User can browse all notifications by pressing **OK** button or confirm all reports at once without browsing by pressing **ALL** button. After confirming all notifications the ALARM LED lights in **red** if at least one exceedance remains. If all exceedances are over, the ALARM LED turns off. If the notification of the same alarm reappears without previous confirmation, only the first message in the message queue is stored.
- Colour change of a result for which the exceedance occurred (the result is displayed in a colour assigned to the alarm and control thresholds).
- Excitation of the output relay – an alarm notification can be linked with excitation of the output relay (for example to connect the sound signalization). Confirmation of displayed notification ends the excitation of the relay. At the programming settings phase, user defines output relays and assign them to the appropriate alarm and control thresholds.
- Marking an exceedance on the 'Alarm and control thresholds' screen – exceeding of the alarm and control thresholds is shown graphically on the screen in a form of symbols **s** or **t** respectively for the upper and lower excess and with the colour assigned to a particular threshold. On this screen are shown simultaneously control exceedances.
- Recording the exceedances in the Event log - exceedances can be recorded in the Event log, depending on the programming, recorded can be just a notification about exceedance, the notification and its ending or just ending. Confirmation about the notification of message is not recorded.
- If a GSM module is connected to the RS-485 port, alarm information can be sent via text message to specified phone numbers.

5.13 Control functions

Using four alarms and control thresholds (with hysteresis) assigned to the results, and four freely programmable output relays, the device can perform simple 'on/off' control functions. Control does not require user support. User can preview the status of the threshold on the detailed screen of the 'Alarm and control thresholds' and the state of output relays on the additional screen **RELAY OUTPUTS** if these screens have not been hidden when programming the device. Exceeding the thresholds during the control can also be recorded in the Event log.

5.14 Failure notification of measurement inputs

Failures associated with particular channels are marked with appropriate symbols on the display.

Symbols of failure:

- F- RTD sensor failure.
- ||- 4-20 mA transducer failure, current below 3.6 mA.
- E- 4-20 mA transducer failure, current above 22 mA.
- S- steam parameters below saturation curve (only when detection of steam saturation is on, see Section 10.4.6).
- R- exceeding the range.
- W- wait (after power on, when data is not ready).
- C- internal communication error.

Symbols of failure are displayed instead of the result for all related channels, e.g. for measurement input and the calculation channel in which the result is used.

No signal from the sensor assigned to the particular input is treated as a failure and marked on the display with the '-F' (failure) symbol. Detection of a failure may trigger displaying the appropriate message and then require confirmation by the user even if the cause of the failure ended earlier. Depending on the settings during programming the device, a failure may cause the excitation of corresponding output relay till the confirmation or for the entire duration of failure. Failure and its disappearance may be recorded in the Event log.

If a GSM module is connected to the RS-485 port, failure information can be sent via text message to specified phone numbers.

5.15 User defined characteristics

For 4-20 mA analog inputs, and the PULS type inputs, it is possible to add the user's characteristics (for transmitters that are neither linear nor square-root). The characteristic can be added to the device using USB port and external memory flash drive. Uploading / deleting characteristics can be run as an authorised function and requires the password. The device can store up to 16 different characteristics. (see Section 10.8.6).

5.16 Audit trail

The device has four logs to record various types of measuring events and activities performed by a user. These are: the totaliser log, the event log, the authorisation log and the calibration log. The content of: the totaliser log, the event log, the authorisation log and the calibration log can be viewed on the device display. In addition, the event log and the authorisation log are available as text files.

5.16.1 Totaliser log

Once a month the totaliser log is saved for all enabled totalisers including information about the time in which the instrument was turned on during the month. The data is Recorded on the day and the hour indicated in the settings in **Nominal month beginning**. In the log are stored 13 last records.

5.16.2 Event log

In the event log are recorded:

- Power supply turning on and off.
- Settings change.
- Date or hour change.
- Resetting of maximum, minimum and average values.
- Resetting of totalisers.
- Beginning and the end of declared thresholds crossing.
- Beginning and the end of superheated steam saturation.
- Beginning and the end of declared input signal failure.
- Change of state of selected binary inputs.

The date and time of each event occurrence is recorded. The device display enables to view the last 500 events. The log is also available as a text file that can be copied and read on a computer (see Section 5.1.4.1. Writing data to flash drive).

In settings a user should declare which thresholds crossing are to be recorded (submenu **Event**), in which systems **steam saturation** is to be recorded system (submenu Steam saturation), which analog inputs failure should be recorded and for which binary inputs shorting (closing) and opening should be recorded (submenu **Actions when failure**, **Actions when closed** and **Actions when open**).

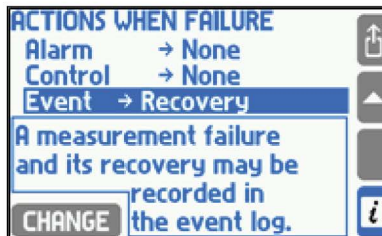
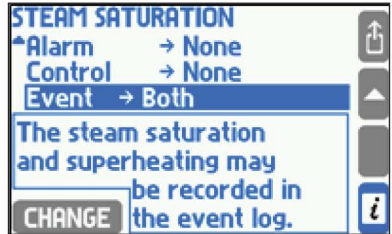
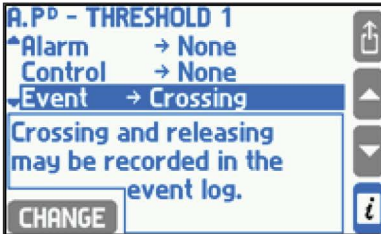

5.16.3 Authorisation log

In authorisation log is recorded each execution of one of commands listed below but only when the respective command requires authorisation (is password protected), (see Section 5.7). These are:

- Creation of a new main archive file.
- Resumption or stopping of archive recording.
- Resetting of maximum, minimum and average values.
- Resetting of totalisers.
- Date and hour change.
- Change of main settings (all except of listed below).
- Change of thresholds settings (value and hysteresis value).
- Change of display settings (screens configuration, backlight and contrast of display).
- Change of archiving settings (recording interval, set of archived values and recording mode).
- Loading of new settings from a file.
- Installation new firmware.

The date and time of each authorised activity is recorded. The device display enables to view the last 500 events. The log is also available as a text file that can be copied and read on a computer (see Section 5.1.4.1. Writing data to flash drive).

5.16.4 Calibration log

In the calibration log each calibration procedure performed by the service or the manufacturer is recorded. Each record includes the following information:

- Date and hour of execution.
- Service executor (serviceman or manufacturer).
- Type of procedure: analog input calibration, temperature drift calibration and removal of all previous calibration.

In the log are stored 50 last calibration procedures. The log is not available in the form of a text file, and can be viewed only on the device display.

5.16.5 Logs browsing on device display

To browse logs, user should log in first. Totaliser log and event log may be browsed by any user whereas authorisation log and calibration log is available only for administrator. To browse logs user has to choose the **Audit trail** submenu from the main menu.

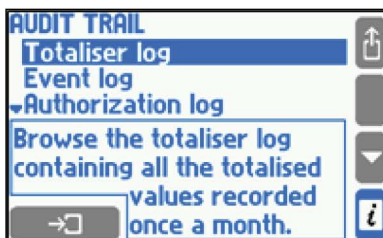
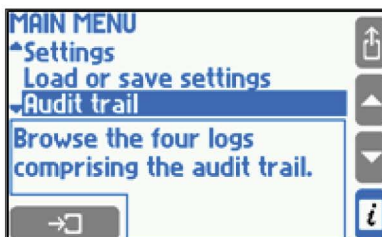
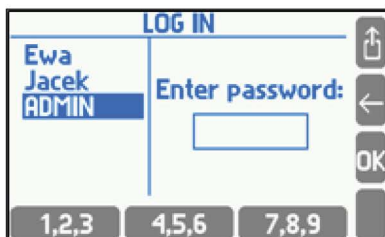

After selecting the totaliser log, the device displays a list of dates and times of available entries. The user should select the right entry and application, then device displays the symbols and states of totalisers in the list.

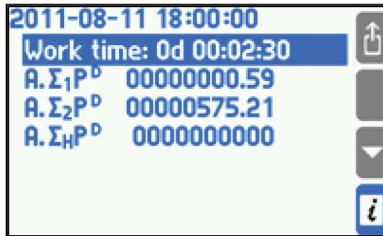
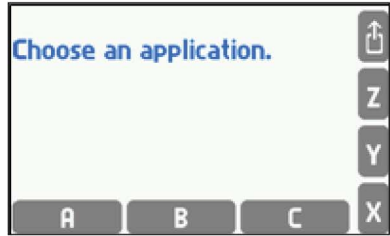
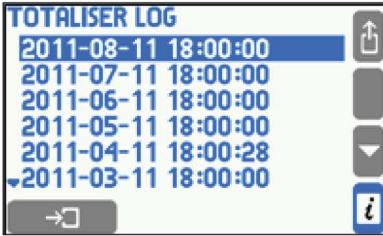

Other logs are displayed in form of a scrolled list. Each line corresponds to one record (event or action). Simultaneously on display there are visible three records. In a frame underneath, additional information about highlighted record is displayed.

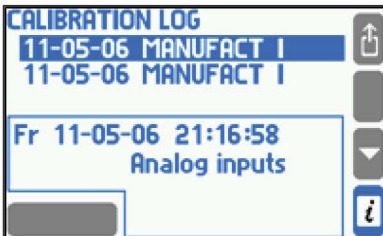
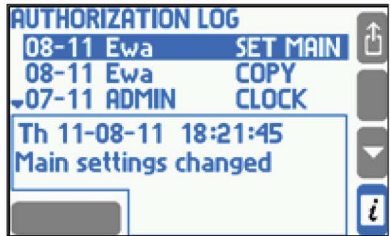
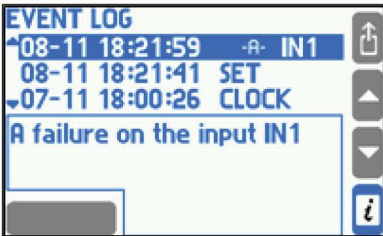

5.16.6 Event and authorisation logs

The 'Event log' and 'Authorisation log' are available for the user in the form of a txt file. (where addr is a double-digit unit address in RS-485 bus).



To distinguish between files from different devices is recommended to configure different addresses even when the RS-485 transmission is not used.

The files are created automatically, and their removal is possible only for the SERVICE user. Log files can be copied to an external USB flash drive, and then transferred to a computer (see Section 5.1.4.1 - Writing data to flash drive). This feature may be password-protected activity. The data in the file are secured with control fields, that allow to determine whether they have been modified outside of the instrument.

5.16.7 Remote logs browsing

The 850-REPORT program allows browsing the content of the event log and the authorisation log using the RS-485 port and ASCII protocol. In this way can be read records and files from internal 2 GB data memory.

6. Internal memory

In the device data are recorded in the internal memory of 2 GB. This capacity provides a record of relatively large amounts of data (see table). The internal memory can hold up to 250 files.

It is necessary to make frequent backups of recorded data. To do this data must be periodically copied from the device to a PC hard drive, data carriers (e.g. CD) or as prints.

In the internal memory data is stored as follows:

- The main archive (archive of process values).
- Totalisers archive.
- Event log and authorisation log files.

Three modes of data recording to the main archive are available: **Overwrite**, **One file**, **Successive file**. In **Overwrite** mode the oldest files are overwritten. In **One file** mode archive is carried until the file reaches the size declared in **File Size**. **Successive file** continue recording after reaching the size declared in File Size. In this mode a new file is created automatically.

A **File size** of the main archive can be limited by a user (see Section 10.12.1).

Data stored in the internal memory can be:

- Read to computer using RS-485 port and ASCII protocol. Due to slow data transmission in this configuration, data should be read relatively often.
- Data files (logs and archives of process values and) can be copied from the device to a USB flash drive and then read on a computer.

Table 3.1. Sample times of data recording in the internal memory of 2 GB.

Warning! The values are indicative.

Recording frequency	3 s	10 s	30 s	1 min	5 min	10 min
16 results	Over 1 year	Over 4 years	Over 10 years	Over 20 years	Over 130 years	Over 260 years
8 results	Over 2 years	Over 7 years	Over 20 years	Over 40 years		
4 results	Over 3 years	Over 10 years	Over 30 years			
1 result	Over 4 years	Over 15 years	Over 40 years			

7. Technical information

M850-W and M850-P

User interface, front panel

Display type	LCD TFT color, 3.5", with LED backlight
Display size/resolution	43.8 mm x 77.4 mm/272 (RGB) x 480 px,
LED indication	3 two-color LEDs, red/green: ALARM, REC, USB
Keyboard	19 membrane buttons

Inputs organisation

Number of inputs	6 x I type (0/4 -20 mA):	IN1, IN2, IN3, IN4, IN5, IN6
	3 x RTD (4-wire):	IN7, IN8, IN9
	3 x PULS:	IN10, IN11, IN12

I type (0/4 -20 mA current loop analog inputs)

Signal type	0-20 mA or 4-20 mA
Transmitter connection	2-wire passive transmitter (supplied from M850) or active transmitter (current source transmitter)
Input resistance	95 Ω \pm 10% (protected with PTC 50 mA fuse in series)
Transmitters supply	24 Vdc +10%/ -20%; max 22 mA per channel (protected with PTC 50 mA fuse and 100 Ω resistor in series)
A/C converter resolution	18 bit (24 bit Sigma-Delta ADC)
50 Hz/60 Hz filter	Sinc3 digital filter
Damping (1st order Low Pass Software Filter time constant)	2 s/5 s/10 s/20 s/30 s/1 min/2 min/3 min/5 min
Measurement resolution	> 0.01% of FS
Accuracy (at T _{amb} = +25 °C/+77 °F)	\pm 0.1% of FS (typical Ω 0.05% of FS)
Temperature drift	Maximum \pm 0.02% of FS/°C
Maximum input voltage	\pm 40 Vdc/SELV
Galvanic isolation between inputs	No; common potential of functional GND for all inputs
Galvanic isolation to Analog Outputs, RS-485/RS-422, Ethernet	250 Vac continuous; 1500 Vac for 1 minute

RTD type (3 analog inputs for temperature sensors)

Sensor types	Pt-100 x K; Ni-100 x K; where K = 1..11 (K – multiplier, e.g.: K = 2 for Pt-200)
Measuring range	-200 .. +850 °C / -328 .. +1562 °F for Pt100 x K -60 .. +150 °C/-76 .. +302 °F for Ni100 x K
Sensor connection	4-wire (2-wire with wire bridges)
Wire resistance compensation	Automatic , additional manual in range -99.99 .. +99.99 Ω
Maximum resistance of connecting wires	50 Ω
A/C converter resolution	18 bit (24 bit Sigma-Delta ADC)
50 Hz/60 Hz filter	Sinc3 digital filter
Damping (1 st order Low Pass Filter time constant)	2 s/5 s/10 s/20 s/30 s/1 min/2 min/3 min/5min
Measurement resolution	> 0.05% of reading or 0.1 Ω (TBV)
Accuracy (at T _{amb} = +25 °C/+77 °F)	±0.5 °C/±0.9 °F (typical ±0.3 °C/±0.54 °F)
Temperature drift	Maximum ±0.02 °C / °C / 0.036 °F/°F
Max input voltage	±40 Vdc/SELV
Galvanic isolation between inputs	No; common potential of functional GND for all inputs
Galvanic isolation to Analog Outputs, RS-485/RS-422, Ethernet	250 Vac continuous; 1500 Vac for 1 minute

PULS type inputs (binary/pulse/frequency)

Measuring range	0 .. 20 kHz (cut off for f < 0.001 Hz) (0 ..1 kHz with filter jumper J1/J2/J3 ON)
Minimum pulse width	25 μs (0.5 ms with filter jumper J1/J2/J3 ON)
Accuracy for frequency measurement (at T _{amb} = +25 °C/+77 °F)	0.02%
Maximum input voltage	±40 Vdc/SELV
Galvanic isolation between inputs	No; common potential of functional GND for all inputs
Galvanic isolation to Analog Outputs, RS-485/RS-422, Ethernet	250 Vac continuous; 1500 Vac for 1 minute
Configuration (default): OC or Contact open / closed	(Internal jumper J4/J5/J6 ON)
Open circuit voltage	5 Vdc
Short circuit current	5 mA
On/off threshold	2.7 V/2.4 V
Configuration: Voltage Input	(Internal jumper J4/J5/J6 OFF)
Signal amplitude	4 .. 36 Vdc
On/off threshold	2.7 V/2.4 V
Input resistance	≥10 kΩ

Compensated flow and heat energy measurement

Calculation update rate	1 s
Total accuracy of compensated steam, water, other liquid or technical gas flow measurement	Typical: better then $\pm 0.5\%$ (worst case: better then $\pm 2\%$)

4 - 20 mA analog output (optional)

Number of outputs	1 or 2
Output signal	4 - 20 mA passive (external current loop supply required)
Resolution	16 bit DAC
Loop resistance (R_L) range for $U_{cc} = 24\text{ V}$	0 .. 600 Ω
Minimum loop power supply voltage	$U_{ccmin} = R_L \times 0.022 + 8$
Maximum loop power supply voltage	28 Vdc/SELV
Accuracy (at $T_{amb} = +25\text{ }^\circ\text{C}/+77\text{ }^\circ\text{F}$)	Better than $\pm 0.2\%$ of FS/ $^\circ\text{C}$
Temperature drift	Maximum $\pm 0.02\%$ of FS/ $^\circ\text{C}$
Galvanic isolation to Analog Inputs, RS-485/RS-422, Ethernet	250 Vac continuous; 1500 Vac for 1 minute

Binary outputs (M850-W-x)

Number of outputs	4
Type of outputs	3 pole (COM, NO, NC) electromechanical relay
Contact rating (resistive load)	3 A at 85 .. 250 Vac/30 Vdc
Maximum switching voltage	250 Vac/125 Vdc
Maximum switching power	750 VA/90 W
Over voltage category	CAT III

Binary outputs (M850-P-x)

Number of outputs	4
Type of outputs	2 pole Solid State Relay
Contact rating (resistive load)	0.1 A at 24 Vac/dc (max 42 Vac or 60 Vdc)/SELV
Maximum ON resistance	20 Ω
Galvanic isolation (optoisolation)	250 Vac continuous; 1500 Vac for 1 minute

RS-485/RS-422

Transmission protocol	ASCII, Modbus RTU, BACnet MSTP, GSM
Number of nodes in network	256
Maximum line length	1 200 m (depends on quality of data cable and baud rate)
Baud rate	2.4, 4.8, 9.6, 19.2, 38.4, 57.6, 115.2, 230.4 kbps
Parity control	Even, Odd, None
Frame	1 start bit, 8 data bits, parity 1 bit, 1 stop bit
Internal terminating resistor	Yes, activated with DIP switch
Maximum bus terminal voltages	-8 V ... +13 V/SELV
Minimal driver differential output voltage	1.5 V (for $R_L = 54 \Omega$)
Minimum receiver sensitivity	200 mV
Short-circuit/thermal protection	Yes
Galvanic isolation to Analog Inputs, Analog Outputs, Ethernet	250 Vac continuous; 1500 Vac for 1 minute



Ethernet port

Transmission protocol	Modbus TCP, ICMP (ping), DHCP server, http server, BACnet IP
Interface	10 BaseT Ethernet
Data buffer	300 B
Number of opened connections (simultaneously)	4
Connection type	RJ-45/SELV
LED indication	2 (build in RJ-45 socket)



USB port (for flash memory stick only)

Socket type	A type, according to USB standard
Version	USB 2.0
Recording format	FAT16 (within a limited scope)

Power supply (M850-W-x)

Rated supply voltage	100-240 Vac; 50/60 Hz 
Supply voltage range	85 .. 264 Vac; 47 .. 63 Hz 
Power consumption	Maximum 20 VA
Over voltage category	CAT III

Power supply (M850-P-x)

Rated supply voltage	24 Vdc  (SELV and Limited Energy Supply)
Supply voltage range	18 .. 36 Vdc 
Power consumption	Maximum 8 W

Wire terminals (M850-W-x)

Wire connection/terminals	Spring type terminal block
Conductor cross section	Solid 0.2 .. 2.5 mm ² Stranded 0.2 .. 1.5 mm ² Stranded with ferrule 0.25 .. 1.5 mm ² AWG 26 .. 12
Cable entry	4 glands type M20, 2 glands type M16

Wire terminals (M850-P-x)

Wire connection/terminals	Screw type terminal blocks, plug type
Conductor cross section	Solid 1.5 mm ² max Stranded 1 mm ² max Stranded with ferrule 0.25 .. 1.5 mm ² AWG 30/14

Enclosure (M850-W-x)

Enclosure type	Wall mounting, Polycarbonate material
Dimensions (height x width x depth)	See Section 8.1 290 mm x 300 mm x 165 mm (in cardboard box)
Weight net (gross)	approx. 1.7 kg
Protection class	IP65

Enclosure (M850-P-x)

Enclosure type	Panel mounting, Lexan Resin 920 material
Dimensions (height x width x depth)	110 mm x 206 mm x 63.5 mm (without terminals) 110 mm x 206 mm x 72 mm (with terminals) 135 mm x 230 mm x 110 mm (in cardboard box)
Panel cut-out dimensions	186 mm x 92 mm
Panel thickness	1 .. 5 mm
Weight net (gross)	approx. 0.6 kg (0.7 kg)
Protection class (front/rear)	IP65/IP20

Environmental conditions

Ambient temperature	0 .. +55 °C (32 .. 131 °F)
Relative humidity	5 .. 95% (non-condensing)
Altitude	≤ 2000 m (6 562 ft) above sea level
Storage temperature	-30 .. +70 °C
Pollution degree	3 Panel version (when installed in an enclosure) 3 Wall version
Electrical safety	EN 61010-1 CAN/CSA-C22.2 No. 61010-1, 3rd Edition
EMC	Immunity EN 61326-1 Table 2 Radiated and conducted emissions EN61326-1 Group 1 Class B
Installation location	Indoor use only

8. Mechanical installation

Note: Before actioning any installation observe the 'Safety information' in Section 2.

M850

The M850 is available for **wall mounting** M850-W-x or for **panel mounting** M850-P-x.

Note: All versions must be fitted away from sources of excessive heat, electrical interference and from all areas liable to flooding.

Safety note - product specific

This product **must** be installed indoors only, in one of the following ways:

Wall mounting

Fit cable glands/conduit with a minimum IP65 rating or install in a clean dry room to provide a pollution degree 3 environment in accordance with EN 60529 (Specification for degrees of protection provided by enclosures - IP code).

- Any unused cable glands/conduit entries **must** be sealed with an appropriate IP blind grommet.

Panel mounting

The panel mount version of the M850 is supplied with an IP65 rated seal to be fitted between the flow computer and the panel it is to be mounted into.

In addition a blanking panel (Figure 7) is also available to reduce the aperture size if you are replacing an existing M800 with the new M850 (also IP65 rated).



Fig. 7 Blanking panel

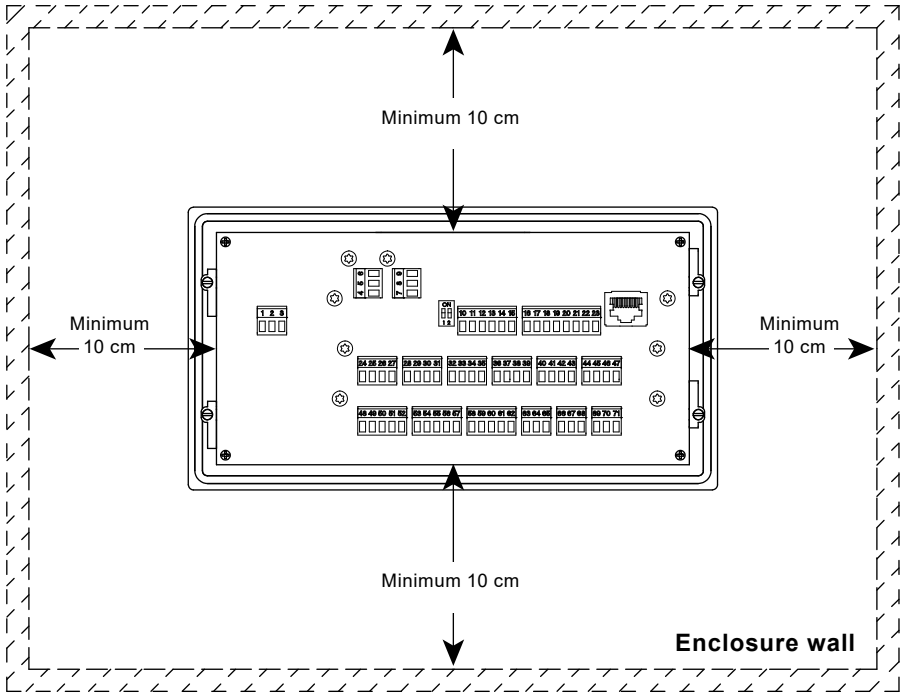

Fig. 8 Panel unit rear view

Environmental conditions

The flow computer should be located in an environment that minimises the effects of heat, vibration, shock and electrical interference.

The flow computer should also be installed away from external magnetic fields, such as those generated from electric motors and large transformers.

Other considerations

Be sure to allow sufficient clearance for:

- Installation of conduit/wiring.
- Viewing of the display.

8.1 Mounting instructions for the wall mounted M850-W:

1. Using the dimensions shown in Figure 8, drill 3 holes suitable for accepting 5 mm (No.10) screws.
2. Remove the terminals enclosure cover to expose the bottom mounting holes.

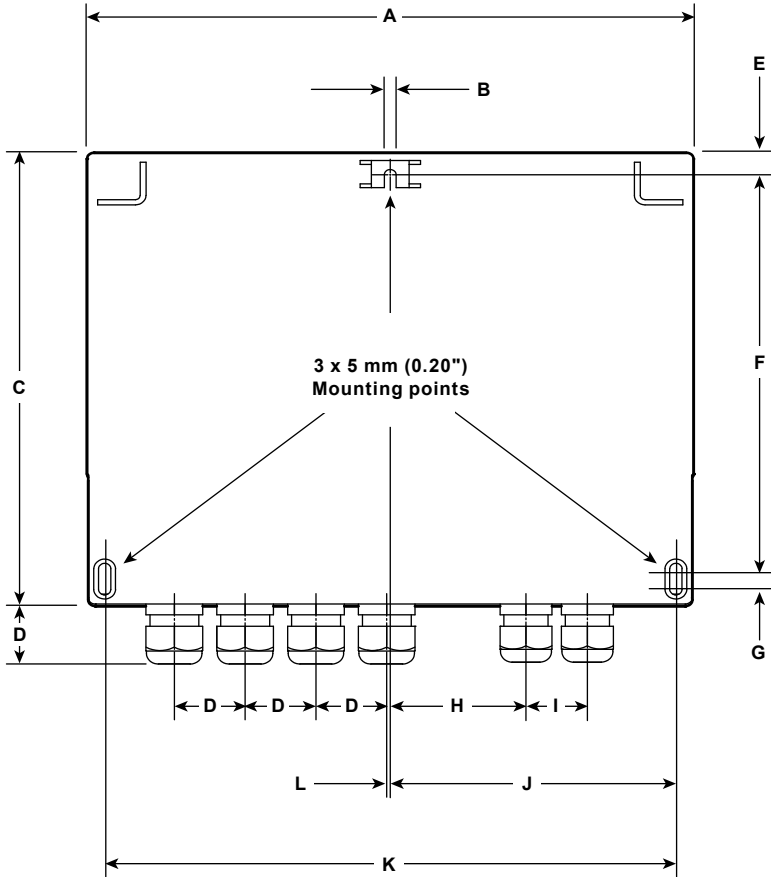

Dimensions (approximate in mm and inches) - M850-W (non cULus version)

A	B	C	D	E	F	G	H	I	J	K	L
257.00 mm	5.00 mm	217.00 mm	30.00 mm	10.60 mm	189.50 mm	10.00 mm	57.50 mm	26.00 mm	121.00 mm	242.00 mm	1.50 mm
10.12"	0.20"	8.54"	1.18"	0.42"	7.46"	0.40"	2.26"	1.02"	4.76"	9.53"	0.06"

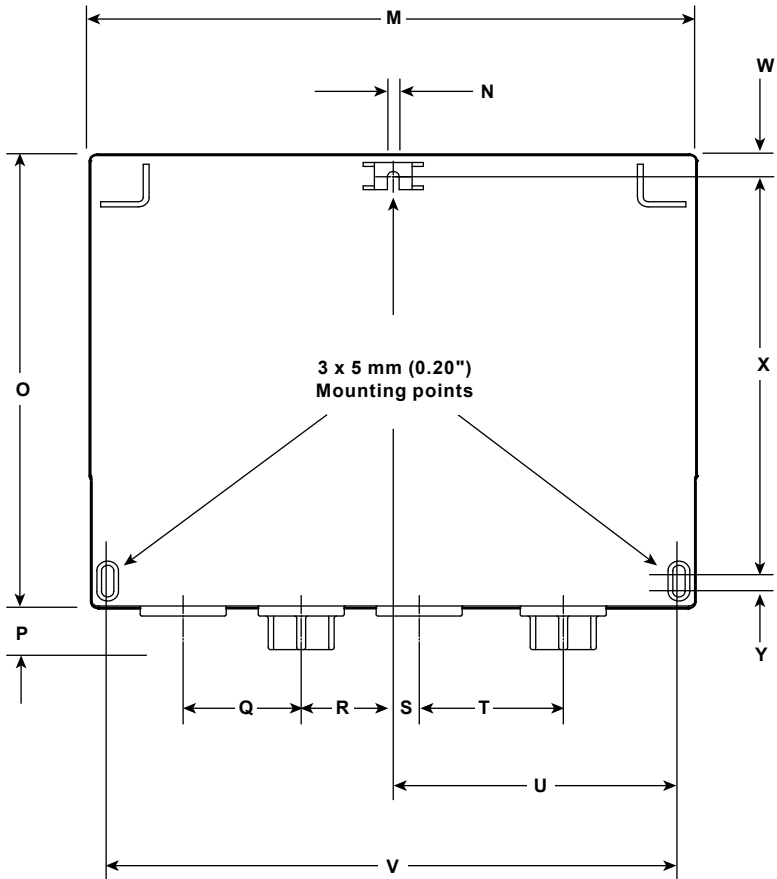

Dimensions (approximate in mm and inches) - M850-W (cULus version)

M	N	O	P	Q	R	S	T	U	V	W	X	Y
257.00 mm	5.00 mm	217.00 mm	21.00 mm	50.00 mm	39.00 mm	11.00 mm	61.00 mm	121.00 mm	242.00 mm	11.00 mm	189.50 mm	10.00 mm
10.12"	0.20"	8.54"	0.83"	1.97"	1.54"	0.43"	2.40"	4.76"	9.53"	0.43"	7.46"	0.39"

M850-W-x



Fig. 9

Bottom mounting eyelet (access through the terminal compartment)

3. Fix an M5 (No.10) screw to the surface for the top mounting. Leave the head of the screw proud of the surface, just enough to allow the top mounting lug of the M850 to slide over.

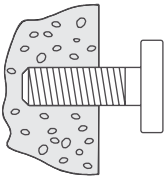

Mounting screw left proud of surface to slot top mounting of M850 over.

4. Slide the top mounting lug over the proud screw.
5. Line up, and fit the screws to the bottom mounting holes.
6. Refit the terminals enclosure cover.

Note: Before actioning any installation observe the 'Safety information' in Section 2.

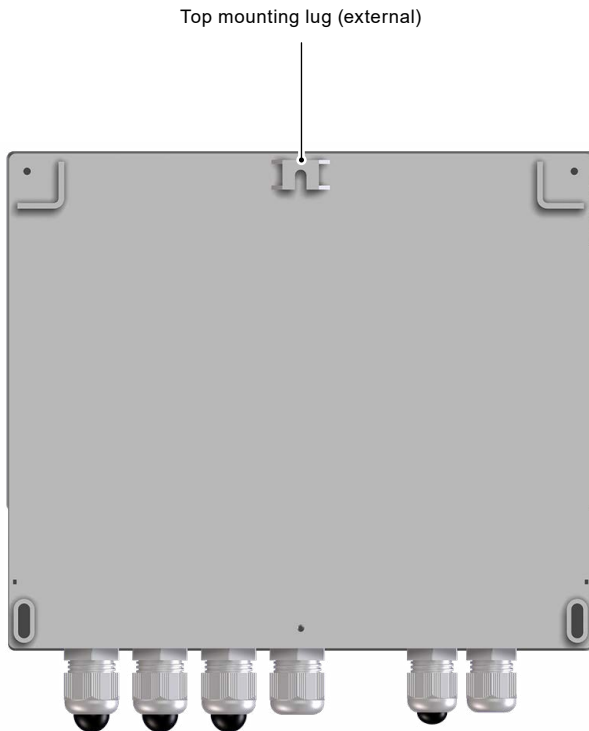

Fig. 10

8.2 Mounting instructions for the panel mounted M850-P:

1. A rectangle aperture 186 mm (7³/₈"") wide x 92 mm (3⁵/₈"") high is required to mount the panel mounted version of the M850 flow computer.
2. Push the M850 through the aperture ensuring that the seal is fitted correctly.
3. From the reverse side of the panel, using the mounting points on the sides of the M850, assemble the fixing clamps to the body.

Note: Screw clamps removed for clarity



Fig. 11

4. Carefully wind in the clamps using the screwdriver slots to tighten the flow computers to the panel.

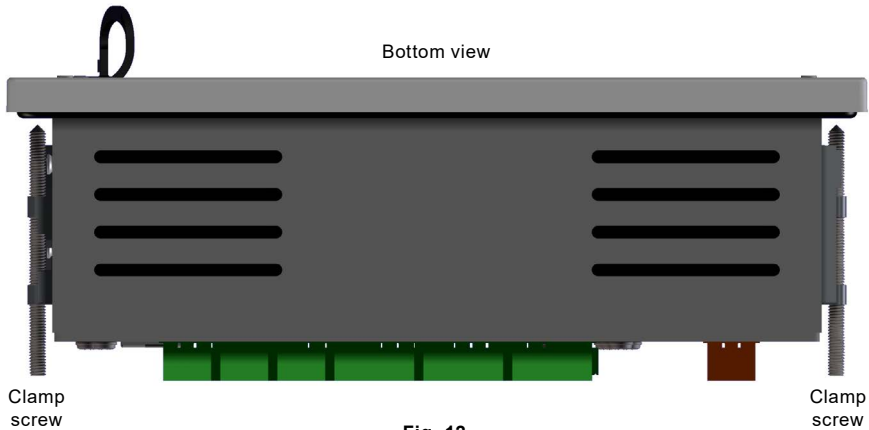

Fig. 12

9. Electrical installation



Note:

Before actioning any installation observe the 'Safety information' in Section 2.

9.1 Important - please read the following general wiring notes:

Every effort has been made during the design of the flow computer to ensure the safety of the user but the following precautions must be followed:

1. Maintenance personnel must be suitably qualified in working with equipment containing hazardous live voltages.
2. Ensure correct installation. Safety may be compromised if the installation of the product is not carried out as specified in this manual.
3. Always isolate the flow computer from the mains supply before opening the unit.
4. The design of the flow computer relies on the building installation for overcurrent protection and primary isolation.
5. Overcurrent protection devices rated at 1 amp must be included in all phase conductors of the installation wiring. If overcurrent protection is included in both supply wires then the operation of one must also cause the operation of the other. Refer to IEC 60364 (Electrical Installations of Buildings) or prevalent local standard for full details of requirements for overcurrent protection.
6. Overcurrent protection devices must be fitted to the relay circuit and appropriately rated for the given loads stated in the technical data.
7. Relay contacts must be supplied at the same phase as the product's mains supply.
8. The wall flow computer (M850-W) is designed as an installation category III product.
9. Install wiring in accordance with:



- IEC 60364 - Low-voltage electrical installation.
 - National and Local Electrical Code (NEC) or Canadian code CEC) for the US and Canadian markets. Note; use NEC Class 1 wire with a temperature rating greater than 75 °C. If the cable is to be exposed to a higher temperature, then a higher temperature rating needs to be selected.
10. All external circuits must meet and maintain the requirements of double /reinforced installation as stated in IEC 60364 or equivalent.
 11. Additional protection must be provided to prevent accessible parts (e.g. signal circuits) from becoming Hazardous Live if a wire or screw is accidentally loosened or freed. Ensure all wires are secured to at least one other wire from the same circuit. The attachment must be as close to the terminal block as possible but must not apply undue stress on the connection. Example, use a cable tie to secure the live and neutral wire together. If one wire becomes loose the other wire will prevent it from touching accessible parts.

12. A disconnecting device (switch or circuit breaker) must be included in the building installation. It must:



- Have a rating with sufficient breaking capacity.
- Be in close proximity to the equipment, within easy reach of the operator but not cause difficulty in operating.
- Disconnect all phase conductors.
- Be marked as the disconnecting device for the flow computer.
- Not interrupt a protective earth conductor.
- Not be incorporated into a mains supply cord.
- Comply with the requirements for a disconnecting device specified in IEC 60947-1 (Specification for low-voltage switchgear and controlgear - General rules) and IEC 60947-3 (Switches, disconnectors, switch-disconnectors and fuse-combination units).

13. It is important that the cable screens are connected as shown in order to comply with the electromagnetic compatibility requirements.

9.2 Important - Please read the following general mains wiring notes:

1. The wiring connections are identified on the label inside the terminal cover of the wall mounting version.
2. Fuses should be installed in all live conductors.
3. Double or reinforced insulation must be maintained between:
 - Hazardous live conductors (mains and relays circuits)
 and
 - Safety extra low voltages (All other components/connectors/conductors).
4. The wiring diagrams show relays and switches in the power off position.

Mains and signal wiring:

For cable/wire recommendations, see Section 9.3.

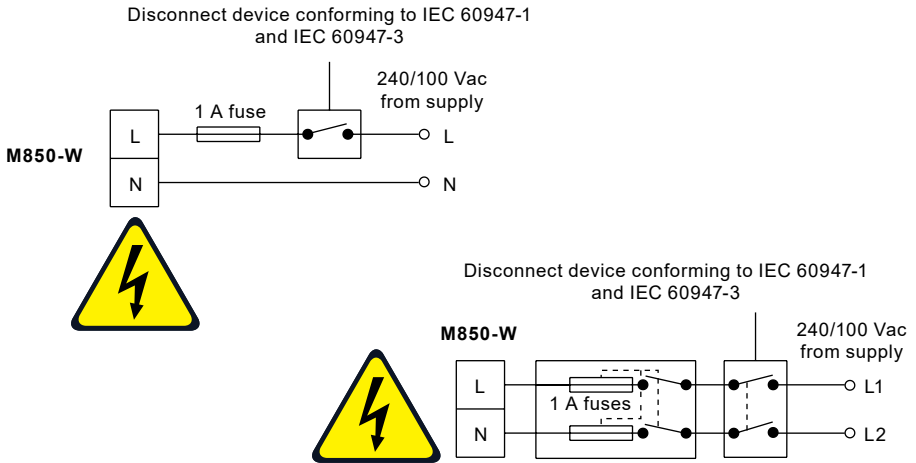

Single phase supply with neutral at earth potential

Screen connection

An earth current loop is created if a wire or screen is connected between two earth points, which are at different potential (voltage). If the instructions are followed correctly, then the screen will only be connected to the earth at one end.

The earth terminal is a functional earth rather than a protective earth.

A protective earth provides protection from electric shock under a single fault condition. This product has double insulation and therefore does not require a protective earth. A functional earth is used in order for the product to operate. In this application, the earth is used as a sink or drain for any electrical interference. The screens must be connected to the earth terminal in order to conform to the EMC directive.

9.3 Cable / wire and connector data

Mains and signal connector

Termination	Rising clamp plug-in terminal blocks with screw connectors.
Cable size	0.02 mm ² (24 AWG) to 2.5 mm ² (12 AWG).
Stripping length	6 mm (¼")

Note: Use only the connectors supplied by Spirax Sarco Ltd – Safety and Approvals may be compromised otherwise.

Pt100 probe

Type	High temperature, twisted
Shield type	Screened
Number of cores	3
Gauge	1 – 1.5 mm ² (18 - 16 AWG)
Maximum length	100 m (328 ft)
Recommended type	Various

0 / 4 - 20 mA output

Type	Twisted pair
Shield type	Screened
Number of pairs	1
Gauge	0.23 - 1 mm ² (24 - 18 AWG)
Maximum length	100 m (328 ft)
Recommended type	Various

RS485 communication

Type	EIA RS485 twisted pair
Shield type	Screened
Number of pairs	2 or 3
Gauge	0.23 mm ² (24 AWG)
Maximum length	1 200 m (4000 ft)
Recommended type	Alpha Wire 6413 or 6414

LAN Cat 5 or Cat 5E ScTP (screened), FTP (foil) or STP (shielded) cable can be used, but limited to 600 m.

Wall mounted M850-W steam flow computer

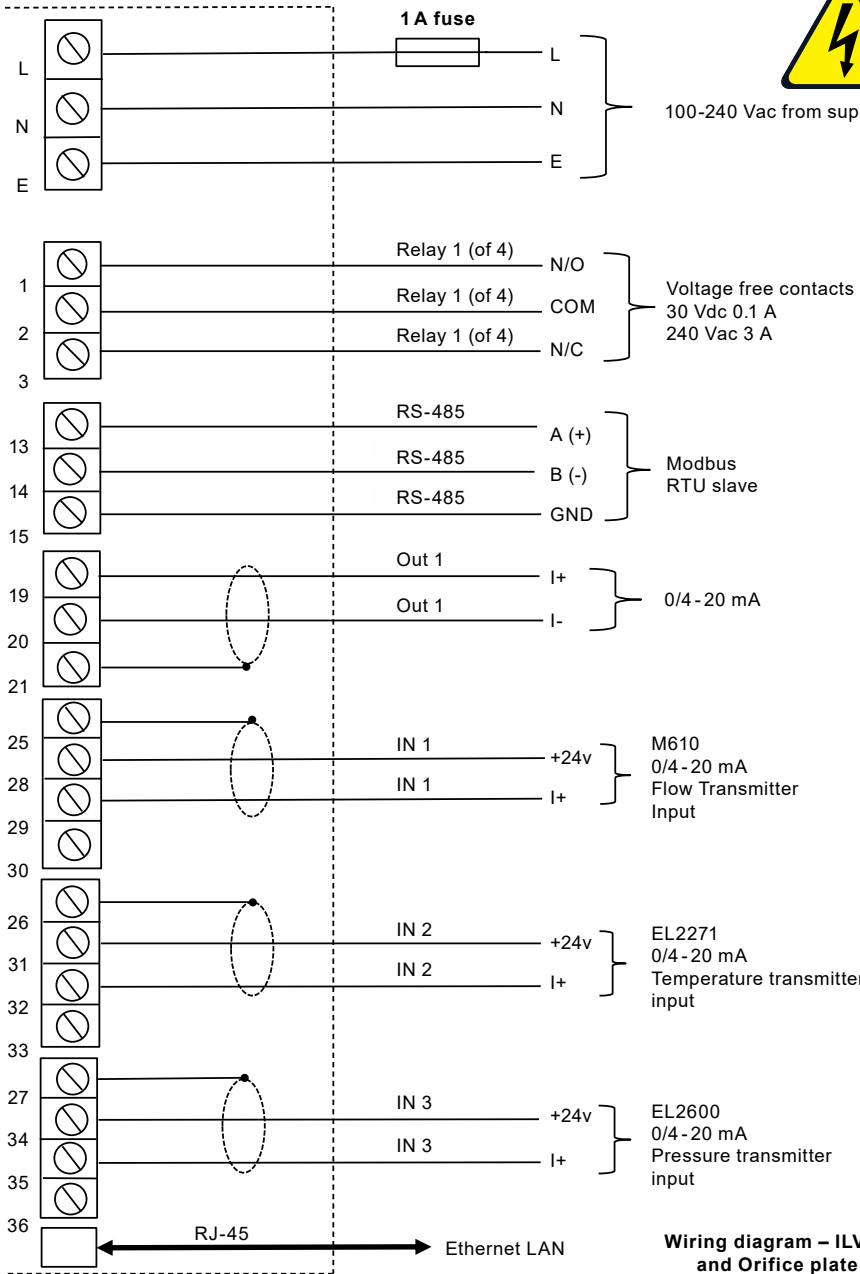

Fig. 13
Wiring diagram – ILVA, Gilflo
and Orifice plate systems

Panel mounted M850-P steam flow computer

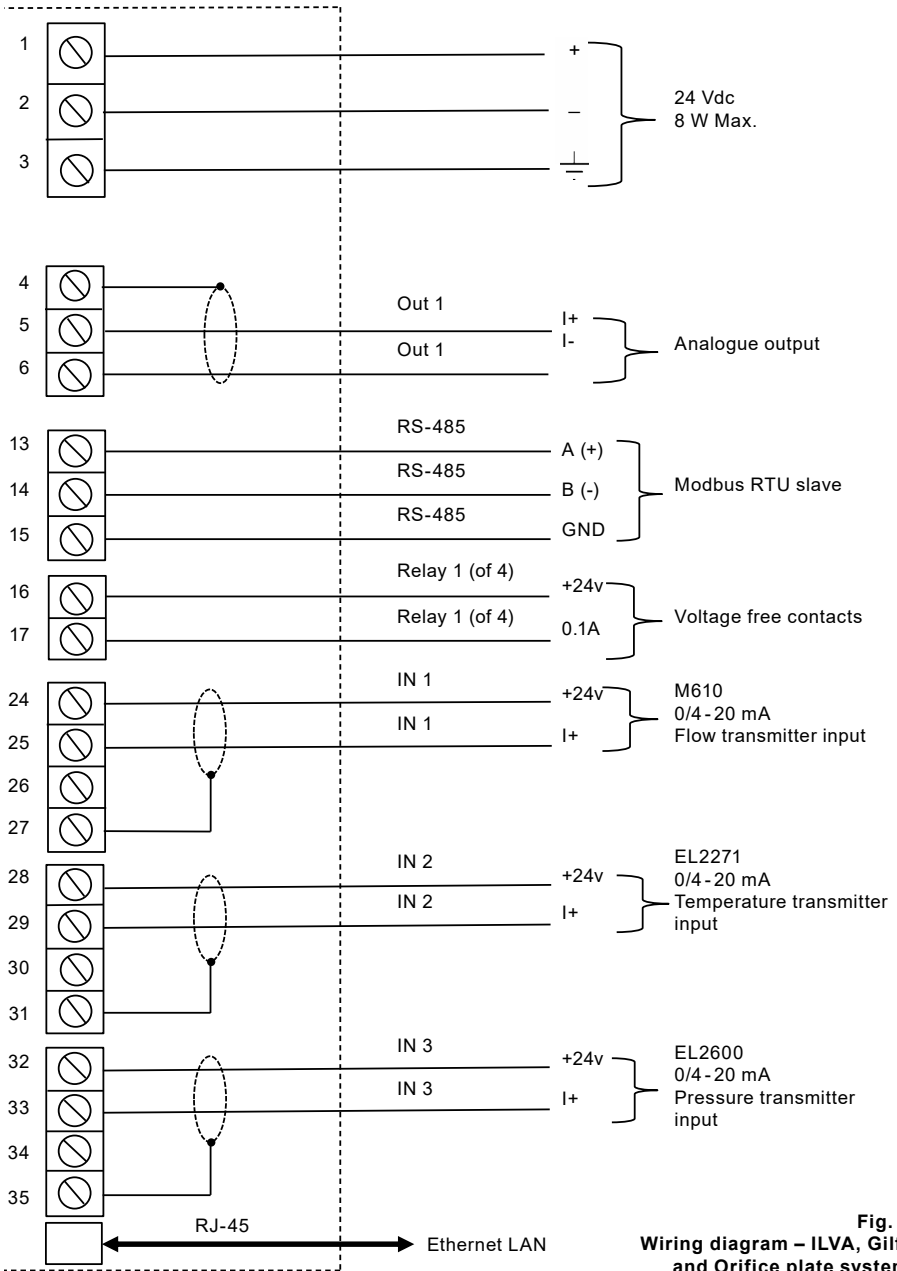



Fig. 14
Wiring diagram – ILVA, Gilflo
and Orifice plate systems

M850-P terminals

No Terminal	Description			
1	+	Power supply 24 Vdc Max.8 W		
2	-			
3				
4	SHLD ^[2]	ANALOG OUTPUT 4-20 mA (optional)	OUT 1	
5	I-			
6	I+			
7	SHLD ^[2]	ANALOG OUTPUT 4-20 mA (optional)	OUT 2	
8	I-			
9	I+			
10	GND	-	RS-422 SERIAL PORT	
11	Y(+)			
12	Z(-)			
13	A(+)			RS-485 SERIAL PORT
14	B(-)			
15	GND			
16		RL 1 (RELAY OUTPUT MAX. 24 V/0.1 A)		
17				
18		RL 2 (RELAY OUTPUT MAX. 24 V/0.1 A)		
19				
20		RL 3 (RELAY OUTPUT MAX. 24 V/0.1 A)		
21				
22		RL 4 (RELAY OUTPUT MAX. 24 V/0.1 A)		
23				
24	+24 V OUT	0/4-20 mA	IN 1	
25	I+			
26	I-			
27	SHLD ^[2]			
28	+24 V OUT	0/4-20 mA	IN 2	
29	I+			
30	I-			
31	SHLD ^[2]			

M850-P terminals (continued)

No Terminal	Description		
32	+24 V OUT	0/4-20 mA	IN 3
33	I+		
34	I-		
35	SHLD ^[2]		
36	+24 V OUT	0/4-20 mA	IN 4
37	I+		
38	I-		
39	SHLD ^[2]		
40	+24 V OUT	0/4-20 mA	IN 5
41	I+		
42	I-		
43	SHLD ^[2]		
44	+24 V OUT	0/4-20 mA	IN 6
45	I+		
46	I-		
47	SHLD ^[2]		
48	I+	RTD	IN 7
49	U+		
50	U-		
51	I-		
52	SHLD ^[2]		
53	I+	RTD	IN 8
54	U+		
55	U-		
56	I-		
57	SHLD ^[2]		
58	I+	RTD	IN 9
59	U+		
60	U-		
61	I-		
62	SHLD ^[2]		

M850-P terminals (continued)

No Terminal	Description		
63	F+	PULSE	IN 10
64	F-		
65	SHLD ^[2]		
66	F+	PULSE	IN 11
67	F-		
68	SHLD ^[2]		
69	F+	PULSE	IN 12
70	F-		
71	SHLD ^[2]		

Ethernet	RJ-45
-----------------	--------------

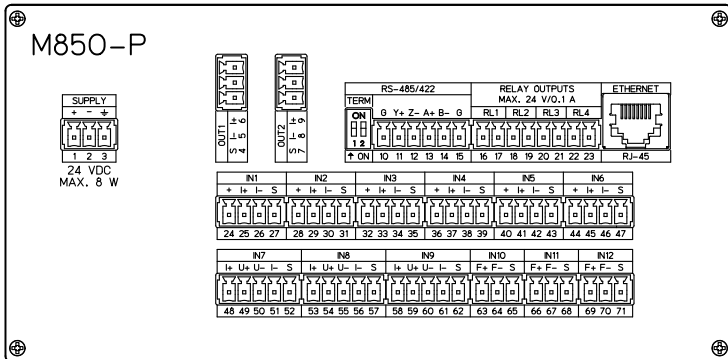

View of the rear plate of the M850-P



M850-W terminals

No Terminal	Description		
1	Normally open		RL 1 (RELAY OUTPUT 240 V/3 A) ^[1]
2		Normally closed	
3			
4	Normally open		RL 2 (RELAY OUTPUT 240 V/3 A) ^[1]
5		Normally closed	
6			
7	Normally open		RL 3 (RELAY OUTPUT 240 V/3 A) ^[1]
8		Normally closed	
9			
10	Normally open		RL 4 (RELAY OUTPUT 240 V/3 A) ^[1]
11		Normally closed	
12			
13	A(+)	RS-485 SERIAL PORT	RS-422 SERIAL PORT
14	B(-)		
15	GND		
16	Y(+)		
17	Z(-)		
18	GND		
19	I+	ANALOG OUTPUT 4 - 20 mA (optional)	OUT 1
20	I-		
21	SHLD[2]		
22	I+	ANALOG OUTPUT 4 - 20 mA (optional)	OUT 2
23	I-		
24	SHLD[2]		
25	SHLD[2]	Shield for IN 1	
26		Shield for IN 2	
27		Shield for IN 3	
28	+24 V OUT	0/4 - 20 mA	IN 1
29	I+		
30	I-		

M850-W terminals (continued)

No Terminal	Description		
31	+24 V OUT	0/4-20 mA	IN 2
32	I+		
33	I-		
34	+24 V OUT	0/4-20 mA	IN 3
35	I+		
36	I-		
37	+24 V OUT	0/4-20 mA	IN 4
38	I+		
39	I-		
40	+24 V OUT	0/4-20 mA	IN 5
41	I+		
42	I-		
43	+24 V OUT	0/4-20 mA	IN 6
44	I+		
45	I-		
46	SHLD ^[2]	Shield for IN 4	
47		Shield for IN 5	
48		Shield for IN 6	
49	I+	RTD	IN 7
50	I-		
51	SHLD ^[2]		
52	U+		
53	U-		
54	SHLD ^[2]		
55	I+	RTD	IN 8
56	I-		
57	SHLD ^[2]		
58	U+		
59	U-		
60	SHLD ^[2]		

M850-W terminals (continued)

No Terminal	Description		
61	I+	RTD	IN 9
62	I-		
63	SHLD ^[2]		
64	U+		
65	U-		
66	SHLD ^[2]		
67	F+	PULSE	IN 10
68	F-		
69	SHLD ^[2]		
70	F+	PULSE	IN 11
71	F-		
72	SHLD ^[2]		
73	F+	PULSE	IN 12
74	F-		
75	SHLD ^[2]		
L	 Mains (100/240 Vac, 60/50 Hz)		
N			
			
Ethernet	RJ-45		

^[1] Relay common contact – in center.

^[2] SHIELD – signal screen terminal for a group belonging to the input/output signals.

SUPPLY 100-240 VAC 50/60 Hz POWER 20 VA MAX.	RELAY OUTPUTS MAX 240V/3A				OUTPUTS X4-20mA	INPUTS												ETHERNET RJ-45
	+ L + L + L - N - N - N 	RL 1 RL 2 RL 3 RL 4 1 4 7 10 NO NO NO NO 2 5 8 11 COM COM COM COM 3 6 9 12 NC NC NC NC	RS422 OUT 1 OUT 2 19 16 19 22 A (+) Y (+) I+ I+ 17 20 23 B (-) Z (-) I- I- 15 18 21 24 GND GND SHLD SHLD	0/4-20mA IN 1 IN 2 IN 3 IN 4 IN 5 IN 6 25 26 31 34 37 40 43 46 49 52 55 58 61 64 67 70 73 SHLD N 1 +24 V +24 V +24 V +24 V +24 V +24 V +24 V +24 V +24 V +24 V +24 V +24 V +24 V +24 V +24 V YE YE YE YE YE YE YE YE YE YE YE YE YE YE YE IN 7 IN 8 IN 9 IN 10 IN 11 IN 12 49 52 55 58 61 64 67 70 73 U+ I+ U+ I+ U+ I+ U+ I+ U+ I+ U+ I+ U+ I+ U+ I+		RTD IN 7 IN 8 IN 9 49 52 55 58 61 64 67 70 73 U+ I+ U+ I+ U+ I+ U+ I+ U+ I+ U+ I+ U+ I+ U+ I+	PULSE IN 10 IN 11 IN 12 67 70 73 F+ F+ F+											

View of the M850-W terminal connection label

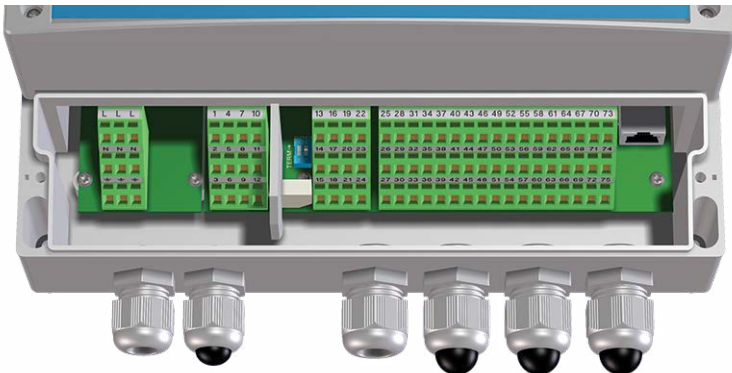

View of the terminal compartment of M850-W-x (non cULus version)

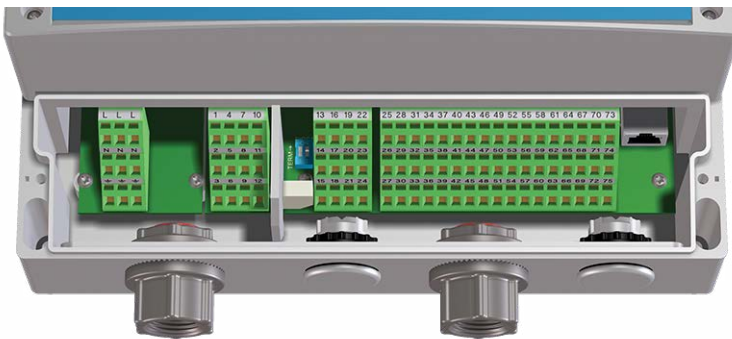



View of the terminal compartment of M850-W-x (cULus version)



M850-W and M850-P Flow Computers



9.4 Power supply connection

The construction of M850-P enables to supply device with 24 Vdc stabilized or not stabilized voltage. It is recommended to supply the flow computer using an isolation power supply rated to 10 W. Terminal marked with the  symbol is functional ground.

The construction of M850-W requires 100 Vac or 240 Vac power supply. Terminals are marked with L (Line) and N (Neutral). Terminals marked with the  symbol are functional ground.

 Terminal marked with the  symbol (functional ground) is required to be connected to GND reference potential of cabinet because of EMC distortion suppression.

9.5 Connecting the RTD type sensors

RTD type inputs are designed for direct connection of temperature sensor type Pt100, Pt200, Pt500, Pt1000 or Ni100. For high precision measurement sensors should be in 4-wire configuration. To connect 2-wire sensors inputs I+, U+ and U-, I- respectively have to be shorted. A software correction of connecting wires resistance is also possible.

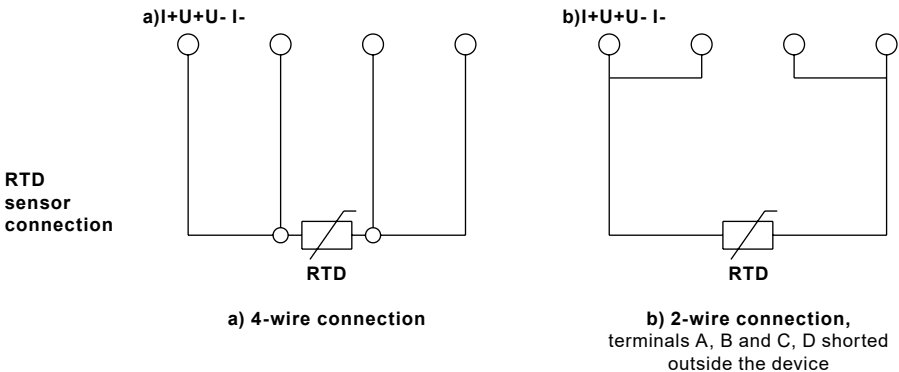

9.6 Analog current loop transmitters 0/4 - 20 mA

The analog inputs are designed for connection of transmitters with output current loop with signal 0-20 mA or 4-20 mA. Each of the inputs has got a +24 V output voltage terminal that can provide power to the transmitter. Voltage source supplying the transmitter loop cannot be loaded with current higher than 22 mA. The ways of connecting transducers are shown on the drawing below.

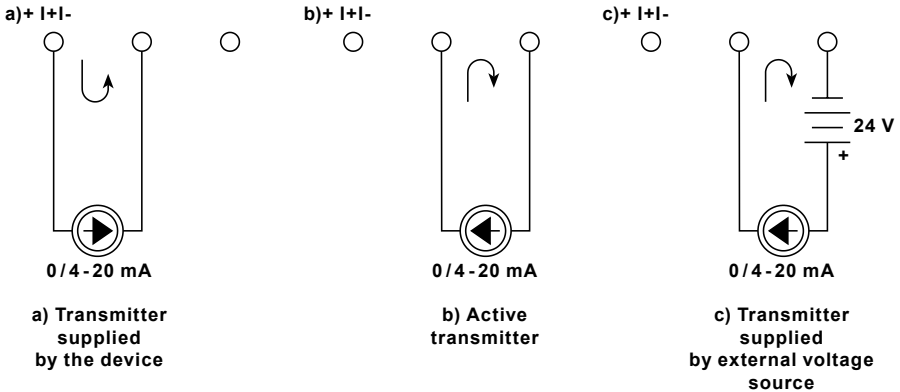

Connection of analog signals 0/4 - 20 mA

! Inputs are not galvanically separated and have no common ground potential. Connected transducers have to be separated and none of the wires can be connected together.

9.7 Connecting transmitters with PULS type inputs

Depending on the configuration the PULSE-type binary inputs can work as a state detector, a pulses counter or a frequency meter.

As a default, the flow computer is supplied in OC configuration (passive signals – the contact type or OC transistor signals). There is also a possibility to connect active voltage signals into input impedance > 10 k Ω . Then the proper jumper configuration has to be set by service staff inside the flow computer (see Section 6).

For contact-type or OC type input, the voltage is 5 Vdc in disconnection state, and the current value in short-circuit state is approx. 5 mA.

For voltage input, the activation threshold is approx. 2.7 V, and deactivation level is approximately 2.4 V. The typical range of the input voltage at high state is 5 .. 24 Vdc.

! Inputs are not galvanically separated and have common ground potential connected to F- terminals. Because of EMC common mode filters it is strongly recommended to connect every pulse transmitter with a separate pair of wires connected to F+ and F- terminals.

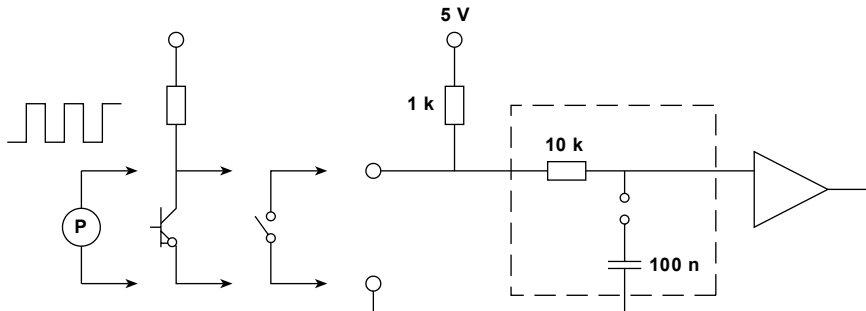

Signal forming circuit for PULS type inputs

For low frequency signals (< 100 Hz) in particular for the contact type transmitters with contact ripple an additional low pass filter can be activated with a jumper to time factor of approx. 1 ms. The default configuration for the filter is off.

! If there is a need for switching on additional low-pass filter, please contact the service staff.

9.8 Connecting the receiver to the 4 -20 mA analog output

The flow computer can be optionally equipped with one or two analog 4 -20 mA current loop outputs. The current loop have to be supplied by an external source. The current outputs are galvanically separated from other circuits of the device.

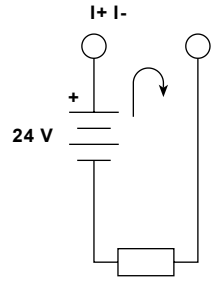

Connecting the receiver to the analog 4 -20 mA output

0 / 4 - 20 mA

9.9 Connecting receivers to binary outputs (RL1 to RL4)

The M850-P device is equipped with 4 isolated solid state relays 100 mA/24 Vdc/ac with the possibility of controlling receivers powered by ac or dc voltage.

Solid state relays outputs are protected with capacitor (4.7 nF) and resistor (30 Ω) connected in series. It is designed to filter overvoltages suppression during inductive load switching (e.g. contactor coil). Nevertheless it is recommended to use additional components (e.g. protective diode, varistor) protecting against overvoltages while connecting inductive load.

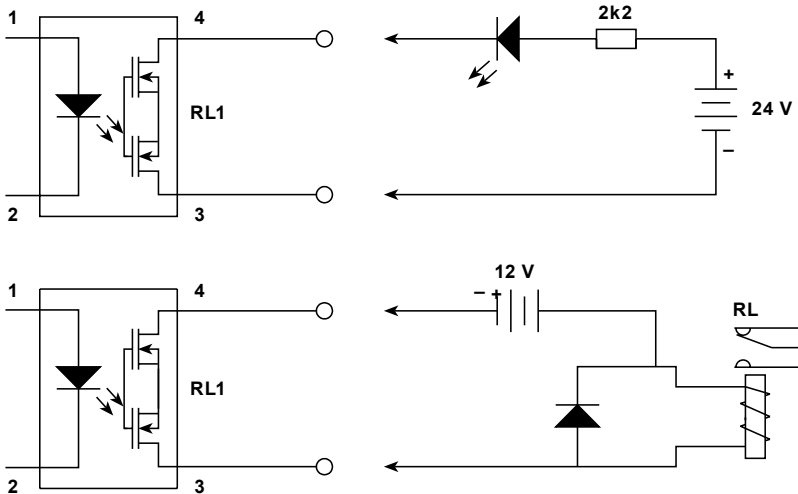

Connecting the receivers to the binary outputs

The intermediary relays should be used to control devices of higher power. In a range upto 6 A/250 Vac it is recommended to install a relay with the LED indication (PI6 1P 24 Vac/dc type) manufactured by Relpol S.A. This relay can be controlled from a dc or ac source, in particular, by the same power supply, which is used to power the device, i.e. transformer 240 V/24 V PSS-10's manufactured by Breve.

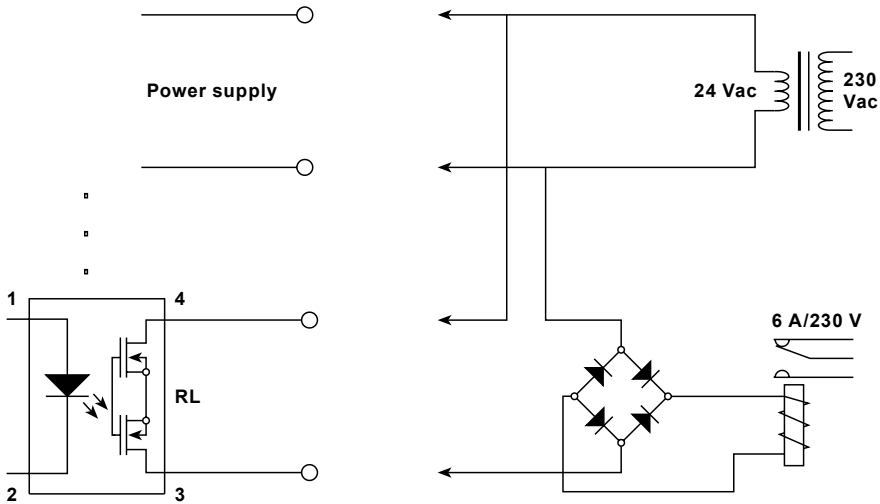

Connecting an additional external relay using a transformer that supplies the device to power the relay circuit

The wall mounting version M850-W has four standard electromechanical power relays rated 3 A/240 Vac or 30 Vdc with NO and NC contacts.

9.10 Connecting data transmission lines to the RS-485/RS-422 port

Depending on the configuration device can be connected to RS-485 or RS-422 network. As a default it is set to RS-485.

RS-485 data lines have to be connected to A(+) and B(-) terminals and 0 V potential to terminal GND. If this device is at the end of the transmission lines, the terminating DIP switch should be switched on.

RS-422 option terminals marked A(+) and B(-) are receiving signals and terminals marked Y(+) and Z(-) are transmitting signal. 0V potential have to be connected to terminal GND. If this device is at the end of the transmission lines, the terminating DIP switch should be switched on.

The RS-485/RS-422 port is galvanically isolated from other circuits of the device.



The RS-485/RS-422 transmission line should not create a star configuration. In industrial conditions it is strongly recommended Shielded Twisted Pair. The screen should be grounded or connected to the reference potential. The RS-485/RS-422 standard allows a connection of up to 32 devices, the maximum line length is 1200 m. It is recommended to use a cable to digital data transmissions.

9.11 Connecting the device to the LAN using the Ethernet port

The flow computer can be connected to industrial Ethernet network (LAN) using the RJ-45, located on the rear panel.

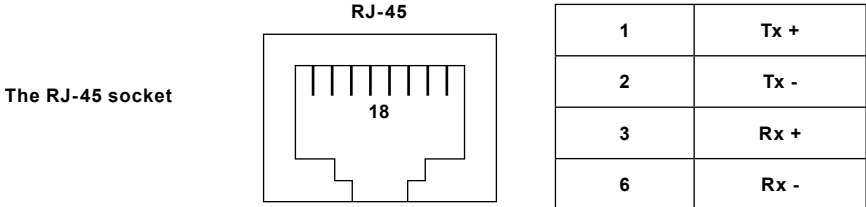

For successful communication between the device and the supervisory system it is necessary to configure all the parameters needed in the communication (see Section 10.14).

9.12 USB port

The USB port with socket type A is located on the front panel. The USB can be used to either download data files from the device or to upload or download configuration data. The socket has a high level of protection IP65 against inside of the device. The contacts are protected against dust by silicon dust cover.

10. Commissioning

In order to ensure convenient and clear readout of process values, all functions and the way they are displayed should be properly configured.

The M850 devices can work in a wide range of applications. It can work with different types of installation and measurement converters, and perform various tasks depending on its configuration. The methods of conversion, the type of measurements and calculations, the form of displaying the results, data archiving and other tasks can all be configured.



A brand new flow computer has all functions deactivated – it does not execute any measurements or calculations. The user must first choose the language and set the units, metric or imperial. Then the device may be configured. The language may be changed later in main menu. In order to change the units between metric and imperial, the device has to be reseted to the factory state.

To perform its relevant tasks the device must be configured or proper settings must be loaded via USB port from USB Flash Memory (pen-drive). All settings are gathered in a hierarchic menu which is entered by selecting **Settings** option from the main menu.

10.1 Content of the settings menu

All settings menu items are listed below – For greater detail on each section, go to the listed number in brackets.

Display (Section 10.16)

User can choose which available screens are displayed and he can configure content of tables on the main (general) screens, resolution of displayed values (except totalisers) and ranges of bargraphs and diagrams. The automatic scrolling can also be configured in this setting group.

Relay outputs (Section 10.7)

In this menu, the relay outputs can be switched between pulse output, alarm and control modes. The relay output section should be configured before assigning relay outputs in the 'main applications' section. For example if an output relay should signal a crossing of an alarm threshold, then the appropriate relay should be assigned to this threshold. To enable such assignment an output relay should be set to the proper mode first. The same relay output can be assigned to many different events (e.g. one relay can signal crossing threshold of multiple process values).

Main applications A, B, C (Section 10.4)

In this section, the parameters of the user application is configured via a setup wizard (flowmeter type/size, steam or water etc).

Auxiliary applications X, Y, Z (Section 10.5)

Only simple process values and calculated values can be entered as an aux application. It is not possible to set e.g. compensated steam flow measurement as an aux application.

Inputs (Section 10.8)

All process values, automatically generated by the main applications and auxiliary applications must be assigned to physical inputs. The 4-20 mA, digital pulse and RTD inputs are all configured in this menu.

Alarms and control (Section 10.9)

1 to 4 control thresholds can be assigned to any process value, with the exception of density... water (k). Thresholds level and hysteresis can be set, and can operate above (upper threshold) or below (lower thresholds) the indicated level. Activation of the threshold can cause various reactions of the device, such as relay output indication.

Totalisers (Section 10.10)

Some measurement parameters like flow rate can have up to 4 totalizers assigned. Totalisers can be undeletable, resettable from the keyboard or may periodically reset itself. Each totaliser can be assigned with a unit and a number of decimal places.

Nominal month beginning (Section 10.1)

For the purpose of the periodically resettable totalisers and the monthly register totalisers user can determine the beginning of the month as any full hour on any day between 1 and 28 or the last day of the month.

4-20 mA output (Section 10.11)

This menu only appears if the device is equipped with an optional 4-20 mA output. The transmitted process value and the values corresponding to 4 mA and 20 mA are entered here.

Main archive (Section 10.12.1) and Hourly archive (Section 10.12.2)

User can select here process values, calculated values and totalisers to be archived, and also the results which are to be recorded as average values. Also a frequency of archiving process values and procedure after memory filling is determined here.

RS-485 port (Section 10.13)

User can set parameters of serial transmission: baud rate, parity control, device address and selects operation mode: Modbus RTU or ASCII (special protocol designed for communication with dedicated programs)

Ethernet Port (Section 10.14)

Parameters needed to communicate through this port: IP address, subnet mask, default gateway can be set in this group.

Text messages (Section 10.15)

Device description (Section 10.1)

The device can be given a name to help identify it.

Barom. pres (Section 10.6)

Allows the local atmospheric pressure to be entered to enable the use of a gauge pressure sensor.

DST (Section 10.17)



Daylight saving time to enable or disable the automatic conversion from summer to winter time and vice versa.

10.2 Basis of configuration

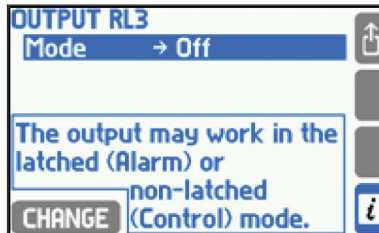
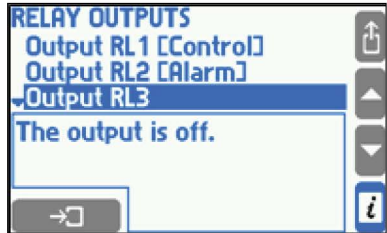
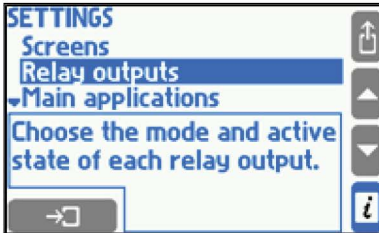

10.2.1 Navigation principles

All settings are in hierarchic menu which is entered by selection of Settings submenu in the main menu. Navigation is executed by entering successive submenus in order to find the required setting.



The example above shows step by step how to find a setting of output relay RL3 operation mode. From settings menu select Relay outputs submenu (placing cursor bar using vertical arrows and then pressing button ). When new submenu appears the user should select **Output RL3** submenu. To return to previous menu user always have to press button  . In the frame below menu some extra explanation information is displayed.

Settings may be viewed and changed without interrupting normal operation of the device. Changes made do not influence immediately on device operation. If some changes are made the device will display confirmation question as follows:

When  button is pressed device operation is interrupted for a few seconds. Then the device resumes with the new settings. Pressing  button denies all changes that were made. Pressing  allows to continue edition of settings.

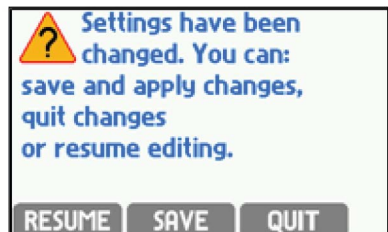

The meaning of respective settings is described with relevant functions in the following Sections.

10.2.2 Editing the settings

In this Section method of editing numerical and text settings selected from a menu list is described. Entering few remaining settings which do not belong to any of these groups were described in Sections explaining their meaning.

To change any setting place the cursor on it and press **CHANGE**. If it is a one-from-the-list setting the cursor moves to the selected option and begins to blink. Choose required option using vertical arrows and confirm new selection with button **OK**. Pressing **ESC** button interrupts edition returning to the previous selection.

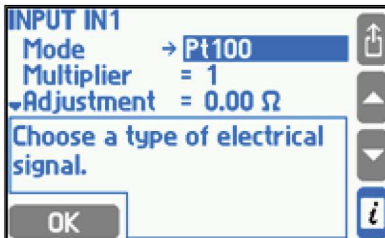
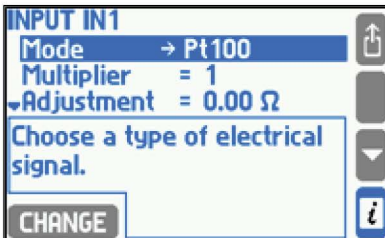

When button **CHANGE** is pressed after selecting a numerical setting the blinking cursor moves to the first digit or the sign of the number that is being changed.

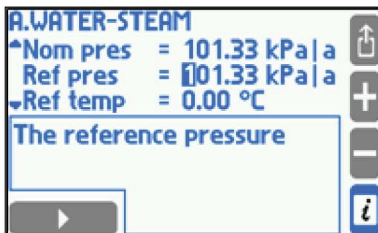
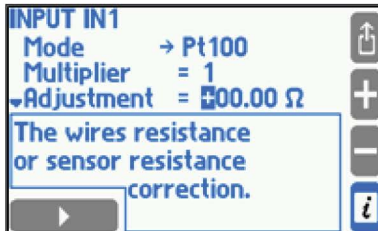
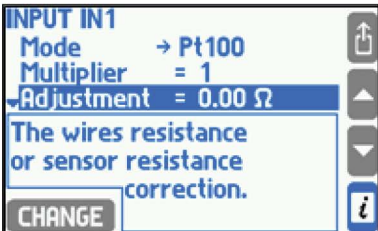

Select the digit value or sign with buttons \oplus or \ominus and confirm with the left bottom button. The cursor moves then to the next digit. In this way all digits can be changed. If the device has an extended keypad the digits are entered using corresponding buttons of the keyboard. Placing the digit automatically moves the cursor to the next position. With button [B] edition can be interrupted returning to the previous value. The entered number must be within the range, otherwise it is rejected.

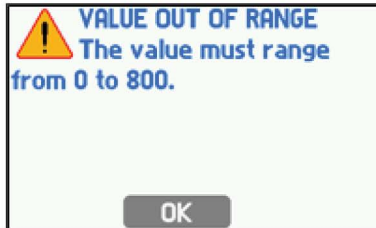



Some numerical settings have constant decimal point position and cannot be changed. Then the cursor moves over decimal point stopping at digits only. In other cases decimal point can be also set. Then dot (decimal point) is available during selection between digit 9 and 0. If the edited number must always be positive the sign will not be displayed and cursor moves to the first digit at once.

Some numerical settings have constant decimal point position and cannot be changed. Then cursor moves over decimal point stopping at digits only. In other cases decimal point can be also set. Then dot (decimal point) is available during selection between digit 9 and 0. If the edited number must be positive the sign is not displayed and cursor moves to the first digit at once.

More complicated settings require selection of values from a list, then entering a number or entering two different numbers in succession. In this case the above described operations should be executed in proper sequence.

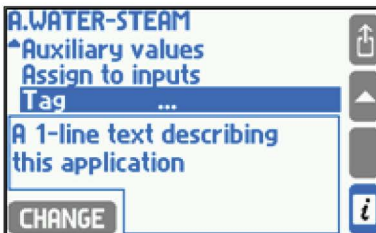
For entering captions a separate screen is called:



Horizontal and vertical arrow buttons move cursor along the whole screen. Left bottom button, depending on cursor position, can insert or delete a mark from edited text or change set of characters on keyboard. Button  is used to leave edition confirming a new text description. There is no possibility to interrupt edition and return to previous text.

To insert a character from keyboard place cursor on it and press **ENTER**. Position in which the character will be inserted is indicated by vertical dash in a frame with edited text. This dash is in place where cursor was at the moment of leaving the frame. To shift the dash move cursor to the frame, put it (using horizontal arrow buttons) in proper place and then return to the keyboard using vertical arrow button. To delete a character from the edited text place cursor on it and press **REMOVE** button. To change set of characters on keyboard place cursor in ABC field (block letters), abc (small letters) or 12-?!. (digits and symbols) and then press **SELECT** button.

Similarly to descriptions other text settings are loaded: symbols of auxiliary results, units (if they are not selected from list) and usernames. In these cases dimension of text in a frame and set of available characters may be different.

Entering text descriptions is much easier in devices with extended keyboard. Pressing one of the extra buttons on the keyboard starts it.



Using the extended keyboard is the same as in mobile phones.

10.3 Configuration sequence

Setting of some parameters may require previous setup of other settings. For example to assign alarm threshold to a relay output first the relay output has to be set to proper mode. Therefore it is recommended to enter settings in sequence they are listed in menu except for Screens which should be configured at the end.

10.4 Selection of the measuring system

The flow computer can operate in three (A, B, C) independent installation applications. Process values and calculations relevant to a single installation application are grouped in one system named main application.

To configure measurements user has to choose **Main applications** from settings menu. Configuration starts with help of a wizard leading through the possible structure of an application. This procedure consists of few questions one have to answer. After completing the wizard new items with specific settings for the selected type of a system appear in the menu. For example if wizard was declared that steam flow measurement is performed with differential pressure device then in the menu appears the parameter **Diff pres device for Δp_D** where some settings have to be entered. Steam or water heat energy measurement also require entering a reference pressure constant and a temperature constant referring to which enthalpy should be calculated.

In next steps user can choose units and enter text descriptions (**Units and tags** submenu), enter auxiliary values if needed (**Auxiliary values**, see Section 10.5), assign calculated values to device inputs (**Assign to inputs**, see Section 10.8.1) and enter a description to the application (**Tag**).

10.4.1 Media types

The device can be configured to the measurement of following types of media: superheated steam, saturated steam, technical gases due to ideal gas equation, hot and cold water and other user defined liquid media.

10.4.1.1 Superheated and saturated water stem

Steam density and enthalpy are calculated according to IAPWS-IF97 standard for pressures 0.05...16.52 MPa and temperatures up to 800 °C. Enthalpy is given relative to a reference point selected by a user (see Section 10.4.7).

In all applications with superheated steam, both pressure and temperature must be measured. Device can detect superheated steam approaching to the saturation state and alarm about such event (see Section 10.4.6). If due to inaccurate measurement, measured steam temperature is slightly lower than condensation temperature at this pressure, density and enthalpy will be calculated for condensation temperature. However if measured temperature is lower than condensation temperature more than 20 °C, an error (–E–) is displayed instead of density and enthalpy values and all other values calculated on their basis.

In systems with saturated steam user can choose if pressure or temperature is measured. The other quantity is always calculated theoretically based on saturation curve. Supervisory measurement of the second quantity can be entered as an auxiliary value within the application.

Limits of steam parameters conversion -> see the illustration in Section 10.4.1.2 'Water'.

10.4.1.2 Water

Water density and enthalpy are calculated according to IAPWS-IF97 standard for pressures 0.05...16.52 MPa. Enthalpy is referred to a user selected reference point (see Section 10.4.7).

Water temperature is always measured whereas pressure may be measured or can be assumed that is constant. Typically it is assumed to be constant and its value is entered in settings. If due to measurement inaccuracy water temperature is slightly higher than boiling temperature at given pressure, density and enthalpy will be calculated for boiling temperature. However if measured temperature exceeds boiling temperature by more than 20 °C an error (-E-) is displayed instead of density and enthalpy values as well as all other values calculated on their basis.

In steam with condensate loop systems, condensate pressure can be treated as equal to steam pressure or its constant value may be entered in settings. There is no possibility of separate steam and condensate pressure measurement in an application. In case of such need two separate applications must be used: one for steam measurement and the second for condensate measurement. Energy balance for both systems can be then implemented with help of auxiliary value (math formula). Condensate temperature may be measured or it may be assumed that condensate remains at boiling temperature – then its temperature is calculated theoretically based on measured steam pressure.

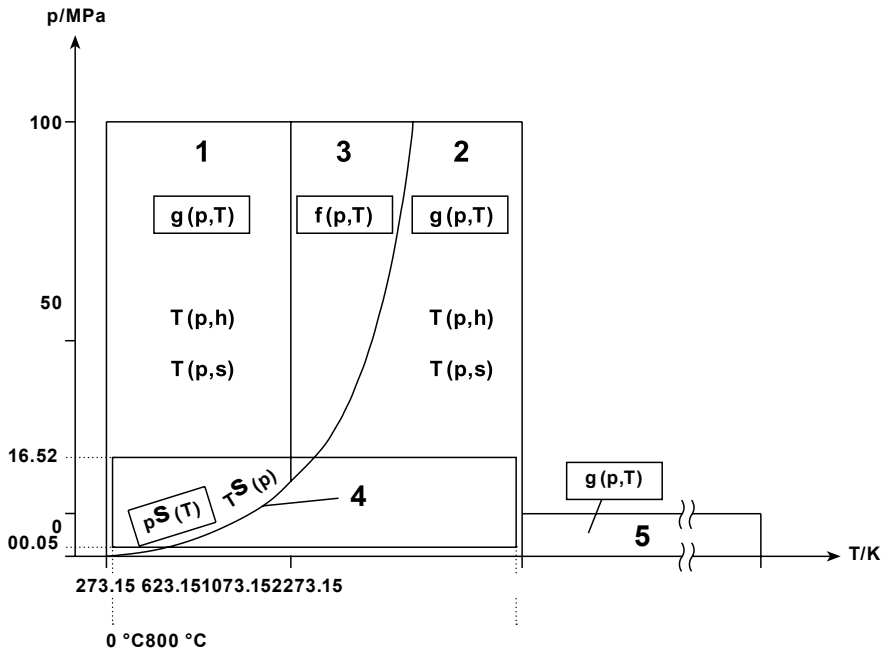

Limits of steam parameters conversion

10.4.1.3 Other liquid media

Flow computer can also measure and calculate process values in installations with any liquid medium other than water. For this purpose tables with medium density and enthalpy as function of temperature should be downloaded from a file using the USB Flash Memory. The pressure can be measured as an auxiliary value only.

A file with information on liquid medium should be prepared on a PC using a text editor or a spreadsheet program. Accepted file formats are .txt or .csv. Below there is an example of such file's contents:

```
#medium Liquid L
0.0820.0
100.0 810.0
200.0 803.0
#
0.00.0
200.0 620.0
```

The file must begin with word #medium followed by name of medium (up to 12 characters, here Liquid) and its symbol (big Latin letter other than B, D, E, G, R, S, W, here L). After that begins a density table containing pairs of numbers (temperature in °C and density in kg/m³). The table ends with symbol # followed by an enthalpy table consisting of pairs of numbers (temperature in °C and enthalpy in kJ/kg). Both tables must be ordered with temperature from lower to higher values. In the example at temperature 200 °C medium density is 803 kg/m³ and enthalpy 620 kJ/kg. Intermediate values between points are linearly interpolated. Therefore for this example density assumed by the device at temperature 50 °C is 815 kg/m³ and enthalpy 155 kJ/kg. Medium temperature cannot exceed range of the table (in this example 0...200 °C); otherwise an error (–E–) is output instead of density or enthalpy values as well as all other values calculated on their base.

Information on liquid media are stored in a data base with all other settings. To view contents of the data base and to add or remove media table choose **Media manager** submenu from main menu.

On media list next to the names there are displayed symbols and occupied memory space. At the screen bottom there is displayed remaining free memory space. The database can store simultaneously up to 16 different media.

To add a new medium user has to insert a USB Flash Memory containing a relevant file in main directory and press button **NEW ONE**. A list will be displayed to select the file. On the list there are only files with extensions .txt or .csv. New medium can also be added during configuration a system with help of wizard without need of entering separately a media manager (see Section 10.4.1.5. Main application configuration wizard). Pressing **REMOVE** button causes removal ALL media and ALL user's characteristics (see Section 10.8.6).

10.4.1.4 Technical gases

The flow computer can also measure and calculate process values in installations with technical gases. A gas pressure and temperature can be either measured or set as constant for one or both values. Actual gas density is calculated according to the ideal gas equation based on density in reference (standard) conditions.

The following flowrates are calculated: mass, actual volumetric and standard volumetric. Units of standard flow rate are preceded by letter C e.g. Cm³/h. The reference conditions (pressure and temperature) are entered in the settings.

The density of measured gas at reference conditions should also be entered in the settings. User has to enter proper value or choose one of the gases from the list. Densities from the list are referred to 0 °C and 101.33 kPa. For other entered reference conditions the density will be calculated automatically according to the ideal gas equation and displayed in a frame below settings.

Air	1.29300 kg/m ³
Oxygen	1.42895 kg/m ³
Nitrogen	1.25050 kg/m ³
Carbon dioxide	1.97700 kg/m ³
Hydrogen	0.08987 kg/m ³
Helium	0.17850 kg/m ³
Chlorine	3.21400 kg/m ³
Methane	0.71680 kg/m ³
Acetylene	1.17090 kg/m ³

10.4.1.5 Main application configuration wizard

New application setup should begin with supporting the wizard with information about the installation type, medium type and applied flowmeters. For this user should choose Installation from the menu. Wizard asks successive questions which must be answered. User selects the answer using arrow buttons and confirms the choice with **NEXT** button. **BACK** button is to return to the previous question. An example sequence of questions and answers for configuring measurement system is shown below:

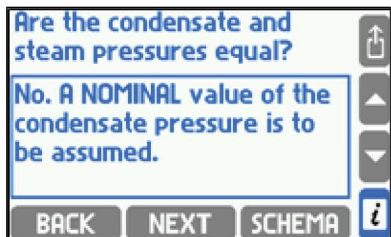
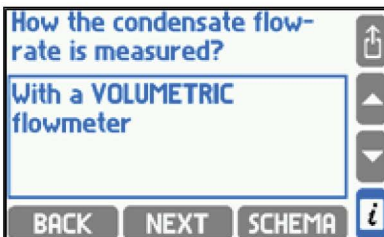
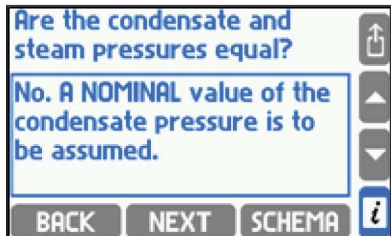
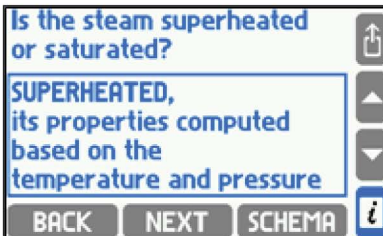
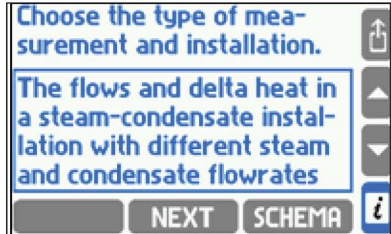
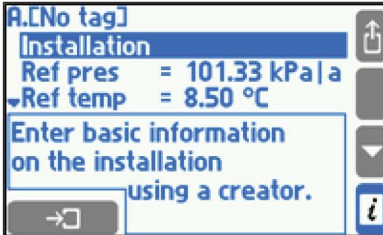

The wizard always asks question about method of flowrate measurement. The following answers are available:

- With a MASS flowmeter
- With a VOLUMETRIC flowmeter
- With a DIFFERENTIAL PRESSURE device
- **COMPUTED from the flowrates in other installations (by a formula)**

In some installations additionally user has to determine the place of flowmeter – on the supply or return pipeline. If a differential pressure device was selected, the wizard inserts automatically **Diff pres device for Δp** submenu in which parameters of this flowmeter should be entered (see Section 10.4.4). If in a given main application no flowmeter has been installed its flowrate can be calculated based on other flowrates, and the last of the listed answers should be selected. This is the case for example when two main applications are connected in series and flowrate is measured only in one of them. Then to system menu **Formula for q_m** submenu is inserted where method of flowrate calculation should be determined (see Section 10.4.5). If mass or volume flowmeter was selected there is no need to enter any additional settings to system menu. Flowmeter parameters should be then entered in the input settings.

If the installation was selected to liquid measurement then the next question wizard will ask about medium type. For selection there are always water and all liquid media in the data base (see Section 10.4.1.3 - Other liquid media). To use a medium which is still not in the data base user has to select answer **Add on a new medium from a file**. This will display a list of available files with media characteristics. Medium of the selected file will be added to the database and immediately set as a medium of the configured system.

If the water or gas pressure or gas temperature is declared as constant, **Nom pres** (nominal pressure) or **Nom temp** (nominal temperature) is inserted to menu.

When the wizard is finished all necessary values are entered to the main application. In submenu Units and tags it is possible to choose the units (see Section 10.6) and set tags. If user chooses answer None, when asked for installation type, the wizard will finish its work and all earlier entered values will be deleted. However wizard has no influence on auxiliary values which also can be entered to the main application even if the installation type was set to **None**.

10.4.2 Graphic schema

Configuration of an installation type can be presented as a graphic schema. To display the schema user should place a cursor on the application and press button **SCHEMA**.

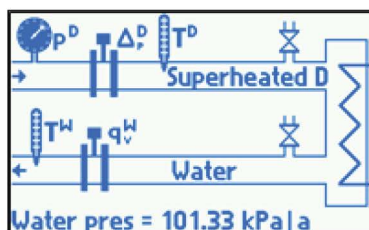
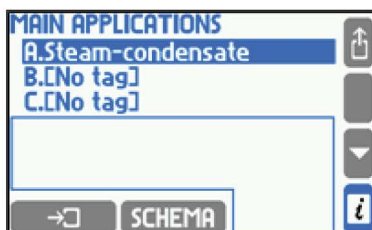

The schema can also be accessed by pressing **SCHEMA** button while using wizard. The schema contains only partial information as far as the wizard questions are answered. With new answers next elements are added to the schema. Schema does not contain information entered beyond wizard such as i.e. constant pressure value.

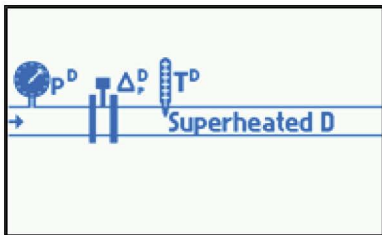
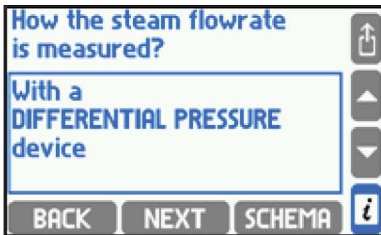
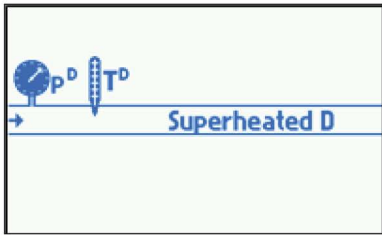
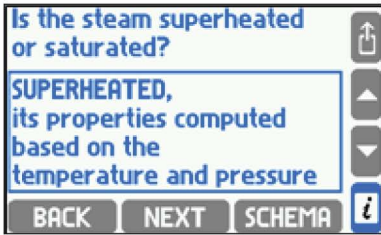
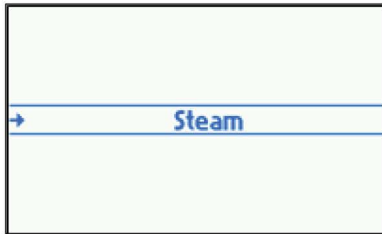
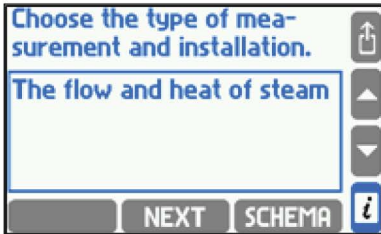

Pressing any button to leave schema and return back to wizard or application menu.

10.4.3 Installation types

10.4.3.1 Flow and heat measurements

In the wizard user must choose a kind of medium: water or other liquid medium. If water was chosen user should determine if the pressure is measured or entered as a constant.

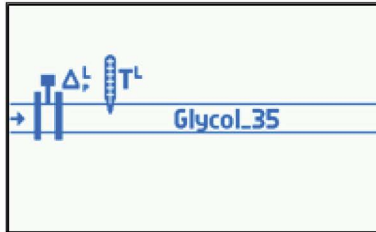
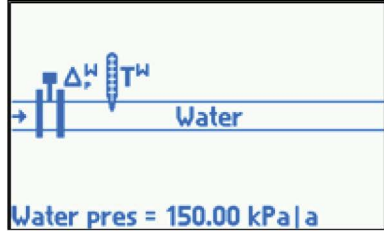
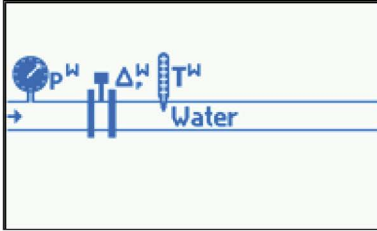

List of process values:

P^W	Heat flowrate.
q_m^W	Mass flowrate.
q_v^W	Volumetric flowrate.
p^W	Pressure (only for water if pressure measurement was declared).
T^W	Temperature.
ρ^W	Density.
h^W	Enthalpy.
Δp^W	Pressure difference at orifice in differential pressure device (only if differential pressure device was chosen).

The upper index letter means a kind of medium. Letter W used in the example above means water whereas other liquid media have their own symbols (see Section 10.4.1.3 - Other liquid media).

10.4.3.2 The flow and differential heat of a liquid in a closed (supply-return) installation

In the wizard user must choose a kind of medium: water or other liquid medium. If water was chosen it should be determined if the pressure is measured or entered as a constant. It is assumed that water pressure at supply and return pipeline are the same.

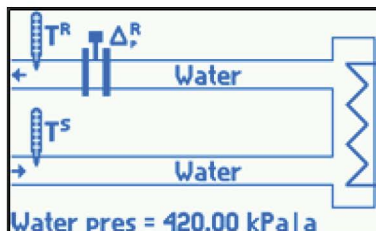
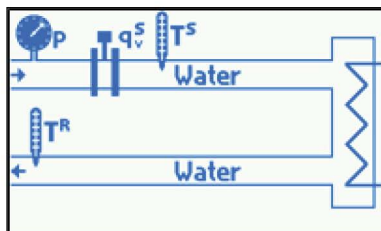

It should be also declared if system fulfills heating (i.e. supplies energy thus supply temperature is higher than return temperature) or cooling (i.e. takes energy away thus supply temperature is lower than return temperature). Heat flowrate difference (P) and temperature difference (ΔT) will be calculated according to this selection. In the schema a principle was assumed that a pipeline with higher temperature is drawn on the top.

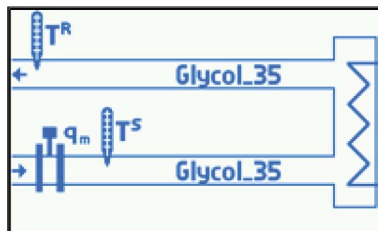

List of process values:

P	Heat flowrate difference between supply and return.
q_m	Mass flow.
q_v^S	Volume flow at supply.
p	Pressure (only for water if pressure measurement was declared).
T^S	Supply temperature.
ρ^S	Density at supply.
h^S	Enthalpy at supply.
Δp^S	Pressure difference at orifice in differential pressure device (only if differential pressure device installed at supply was chosen).
q_v^R	Volume flow at return.
T^R	Temperature at return.
ρ^R	Density at return.
h^R	Enthalpy at return.
Δp^R	Pressure difference at orifice in differential pressure device (only if differential pressure device installed at return was chosen).
ΔT	Temperature difference between supply and return.
k^S	Water thermal coefficient (only if volume flowmeter was installed at supply).
k^R	Water thermal coefficient (only if volume flowmeter was installed at return).

10.4.3.3

The flows and differential heat of a liquid in an installation with separate supply and return flowrates

In the wizard user must choose a kind of medium: water or other liquid medium. If water was chosen it should be also determined if the pressure is measured or entered as a constant. It is assumed that water pressure at supply and return are the same.

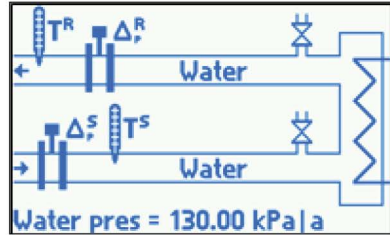
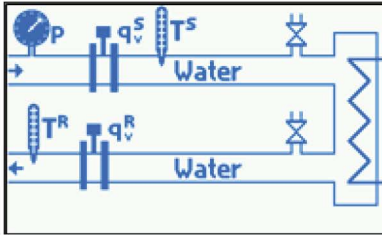

It should be also declared if system fulfills heating (i.e. supplies energy thus supply temperature is higher than return temperature) or cooling (i.e. takes energy away thus supply temperature is lower than return temperature). Heat flowrate difference (P) and temperature difference (ΔT) will be calculated according to this selection. In the schema a principle was assumed that a pipeline with higher temperature is drawn on the top.

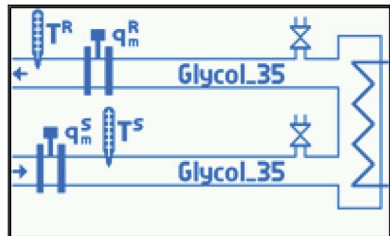

List of process values:

P	Heat flowrate difference between supply and return.
q_m^S	Mass flowrate at supply.
q_v^S	Volume flowrate at supply.
p	Pressure (only for water if pressure measurement was declared).
T^S	Temperature at supply.
ρ^S	Density at supply.
h^S	Enthalpy at supply.
Δp^S	Pressure difference at orifice in differential pressure device (only if differential pressure device was chosen).
q_m^R	Mass flowrate at return.
q_v^R	Volume flowrate at return.
T^R	Temperature at return.
ρ^R	Density at return.
h^R	Enthalpy at return.
Δp^R	Pressure difference at orifice in differential pressure device at return (only if differential pressure device was chosen).
ΔT	Temperature difference between supply and return.

10.4.3.4 The flow and heat of steam

In the wizard user must choose a kind of medium: superheated or saturated. If saturated steam was chosen it should be determined if pressure or temperature is measured.

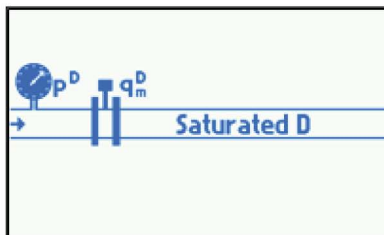
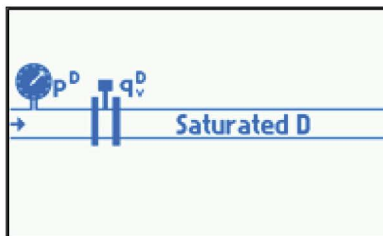
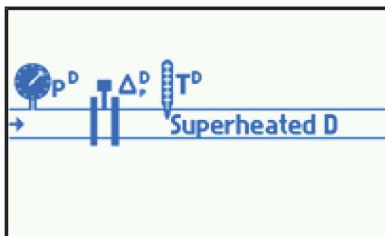

List of process values:

P^D	Heat flowrate of steam.
q_m^D	Mass flowrate of steam.
q_v^D	Volume flowrate of steam.
p^D	Steam measured pressure (only for superheated or saturated steam with pressure measurement).
P_c^D	Saturated steam pressure calculated based on saturation curve (only for saturated steam with temperature measurement).
T^D	Steam measured temperature (only for superheated or saturated steam with temperature measurement).
T_c^D	Saturated steam temperature based on saturation curve (only for saturated steam with pressure measurement).
ρ^D	Steam density.
h^D	Steam enthalpy.
Δp^D	Pressure difference at orifice in differential pressure device (only if differential pressure device was chosen).

10.4.3.5 The flow and differential heat in a closed steam-condensate installation

In this installation it is assumed that condensate is returned continuously (condensate mass flowrate is equal to steam flowrate). If condensate is accumulated and periodically pumped out, system described in Section 10.4.3.6. The flows and differential heat in a steam-condensate installation with partial return of condensate should be selected.

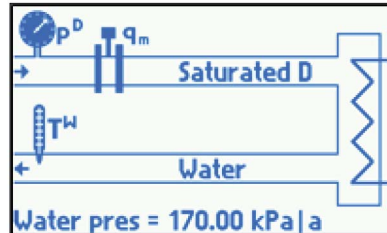
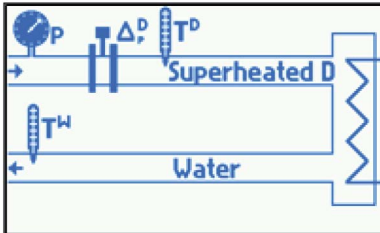

In the wizard user must choose a kind of medium: superheated or saturated. If saturated steam was chosen it should be determined if the pressure or temperature is measured.

It should also be declared if condensate pressure is equal to steam pressure or entered as a constant value. In some installations if steam and condensate pressures are equal user can skip condensate temperature measurement and assume calculations at the boiling temperature.

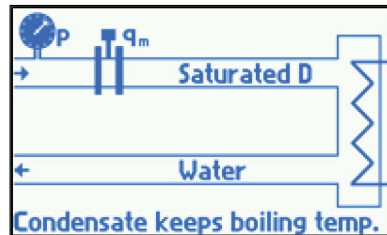

List of process values for condensate with constant (entered) pressure:

P	Delta heat between steam and condensate.
P ^D	Steam heat flowrate.
q _m	Mass flowrate.
q _v ^D	Steam volume flowrate.
p ^D	Steam measured pressure (only for superheated or saturated steam with pressure measurement).
P _c ^D	Saturated steam pressure calculated based on saturation curve (only for saturated steam with temperature measurement).
T ^D	Steam measured temperature (only for superheated or saturated steam with temperature measurement).
T _c ^D	Saturated steam temperature calculated based on saturation curve (only for saturated steam with pressure measurement).
ρ ^D	Steam density.
h ^D	Steam enthalpy.
Δp ^D	Pressure difference at orifice in differential pressure device (only if differential pressure device was chosen).
P ^W	Condensate heat flowrate.
q _v ^W	Condensate volume flowrate.
T ^W	Condensate temperature.
ρ ^W	Condensate density.
h ^W	Condensate enthalpy.

List of process values for condensate with pressure equal to steam pressure and measured temperature:

P	Delta heat between steam and condensate.
P ^D	Steam heat flowrate.
q _m	Mass flowrate.
q _v ^D	Steam volume flowrate.
p ^D	Steam and condensate measured pressure (only for superheated or saturated steam with pressure measurement).
p _c ^D	Saturated steam and condensate pressure calculated based on saturation curve (only for saturated steam with temperature measurement).
T ^D	Steam measured temperature (only for superheated or saturated steam with temperature measurement).
T _c ^D	Saturated steam temperature calculated based on saturation curve (only for saturated steam with pressure measurement).
ρ ^D	Steam density.
h ^D	Steam enthalpy.
Δp ^D	Pressure difference at orifice in differential pressure device (only if differential pressure device was chosen).
P ^W	Condensate heat flowrate.
q _v ^W	Condensate volume flowrate.
T ^W	Condensate temperature.
ρ ^W	Condensate density.
h ^W	Condensate enthalpy.

List of process values for condensate remaining in boiling temperature:

P	Delta heat between steam and condensate.
P ^D	Steam heat flowrate.
q _m	Mass flowrate.
q _v ^D	Steam volume flowrate.
p ^D	Steam and condensate measured pressure (only for superheated or saturated steam with pressure measurement).
p _c ^D	Saturated steam and condensate pressure calculated based on saturation curve (only for saturated steam with temperature measurement).
T ^D	Superheated steam measured temperature (only for superheated steam).
T _c	Saturated steam temperature calculated based on saturation curve; it is also boiling condensate temperature (only for saturated steam with pressure measurement).
ρ ^D	Steam density.
h ^D	Steam enthalpy.
Δp ^D	Pressure difference at orifice in differential pressure device (only if differential pressure device was chosen).
P ^W	Condensate heat flowrate.
q _v ^W	Condensate volume flowrate.
T _c ^W	Condensate temperature (only for superheated steam).
ρ ^W	Condensate density.
h ^W	Condensate enthalpy.

10.4.3.6 The flows and differential heat in a steam-condensate installation with partial return of condensate

This installation should be chosen also when condensate is accumulated and periodically pumped out.

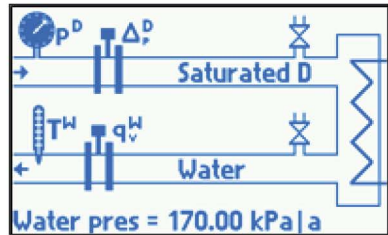
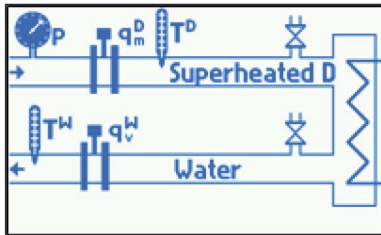

In the wizard user must choose a kind of medium: superheated or saturated steam. If saturated steam was chosen it should be determined if the pressure or temperature is measured.

It should also be declared if condensate pressure is equal to steam pressure or entered as a constant value.

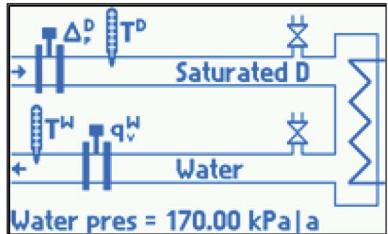

List of process values for condensate with constant (entered) pressure:

P	Delta heat between steam and condensate.
P ^D	Steam heat flowrate.
q _m ^D	Steam mass flowrate.
q _v ^D	Steam volume flowrate.
p ^D	Steam measured pressure (only for superheated or saturated steam with pressure measurement).
P _c ^D	Saturated steam pressure calculated based on saturation curve (only for saturated steam with temperature measurement).
T ^D	Steam measured temperature (only for superheated or saturated steam with temperature measurement).
T _c ^D	Saturated steam temperature calculated based on saturation curve (only for saturated steam with pressure measurement).
ρ ^D	Steam density.
h ^D	Steam enthalpy.
Δp ^D	Pressure difference at orifice in differential pressure device (only if differential pressure device was chosen).
P ^W	Condensate heat flowrate.
q _m ^W	Condensate mass flowrate.
q _v ^W	Condensate volume flowrate.
T ^W	Condensate temperature.
ρ ^W	Condensate density.
h ^W	Condensate enthalpy.

List of process values for condensate with pressure equal to steam pressure:

P	Delta heat between steam and condensate.
P^D	Steam heat flowrate.
q_m^D	Steam mass flowrate.
q_v^D	Steam volume flowrate.
p	Steam and condensate measured pressure (only for superheated or saturated steam with pressure measurement).
P_c	Saturated steam and condensate pressure calculated based on saturation curve (only for saturated steam with temperature measurement).
T^D	Steam measured temperature (only for superheated or saturated steam with temperature measurement).
T_C^D	Saturated steam temperature calculated based on saturation curve (only for saturated steam with pressure measurement).
ρ^D	Steam density.
h^D	Steam enthalpy.
Δp^D	Pressure difference at orifice in differential pressure device (only if differential pressure device was chosen).
P^W	Condensate heat flowrate.
q_m^W	Condensate mass flowrate.
q_v^W	Condensate volume flowrate.
T^W	Condensate temperature.
ρ^W	Condensate density.
h^W	Condensate enthalpy.

10.4.3.7 The flow and differential heat in a steam-generating installation with the supplied water flowrate measured

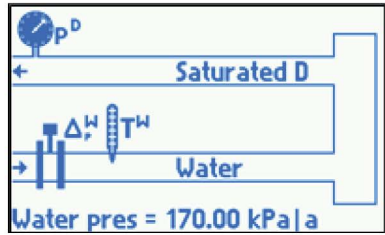
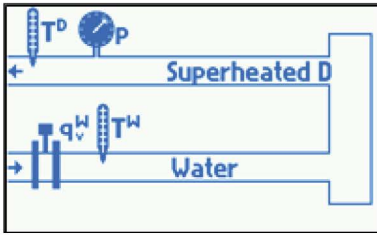

In the wizard user must choose a kind of medium: superheated or saturated. If saturated steam was chosen it should be determined if the pressure or temperature is measured.

It should also be declared if condensate pressure is equal to steam pressure or entered as a constant value.

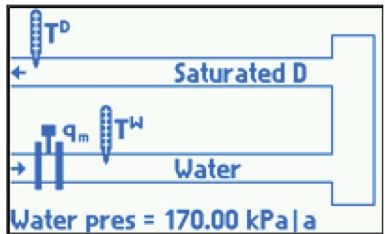

List of process values for water with constant (entered) pressure:

P	Delta heat between generated steam and supplied water.
P ^D	Steam heat flowrate.
q _m	Mass flowrate.
q _v ^D	Steam volume flowrate.
p ^D	Steam measured pressure (only for superheated or saturated steam with pressure measurement).
P _c ^D	Saturated steam pressure calculated based on saturation curve (only for saturated steam with temperature measurement).
T ^D	Steam measured temperature (only for superheated or saturated steam with temperature measurement).
T _c ^D	Saturated steam temperature calculated based on saturation curve (only for saturated steam with pressure measurement).
ρ ^D	Steam density.
h ^D	Steam enthalpy.
P ^W	Water heat flowrate.
q _v ^W	Water volume flowrate.
T ^W	Water temperature.
ρ ^W	Water density.
h ^W	Water enthalpy.
Δp ^W	Pressure difference at orifice in differential pressure device (only if differential pressure device was chosen).

List of values for water with pressure equal to generated steam pressure:

P	Delta heat between generated steam and supplied water.
P^D	Steam heat flowrate.
q_m	Mass flowrate.
q_v^D	Steam volume flowrate.
P	Steam and water measured pressure (only for superheated or saturated steam with pressure measurement).
P_c	Saturated steam and water pressure calculated based on saturation curve (only for saturated steam with temperature measurement).
T^D	Steam measured temperature (only for superheated or saturated steam with temperature measurement).
T_c^D	Saturated steam temperature calculated based on saturation curve (only for saturated steam with pressure measurement).
ρ^D	Steam density.
h^D	Steam enthalpy.
P^W	Water heat flowrate.
q_v^W	Water volume flowrate.
T^W	Water temperature.
ρ^W	Water density.
h^W	Water enthalpy.
Δp^W	Pressure difference at orifice in differential pressure device (only if differential pressure device was chosen).

10.4.3.8 The flow of a gas

It must be declared if the pressure and temperature is measured or entered as a constant value.

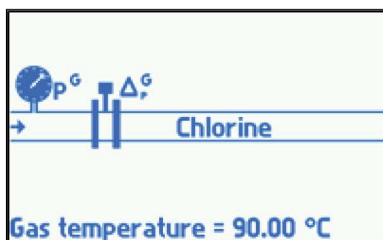
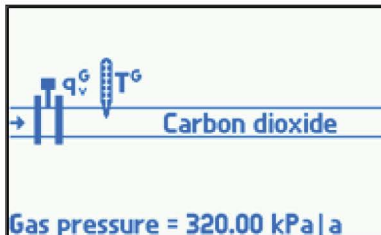
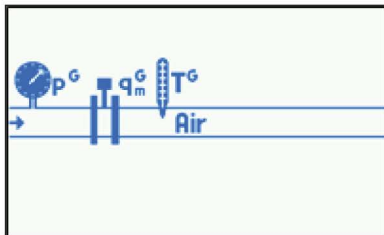

List of process values:

q^G	Gas volume flowrate in standard units (volume calculated to reference conditions).
q_m^G	Gas mass flowrate.
q_v^G	Gas actual volume flowrate.
p^G	Gas pressure (only if pressure is measured).
T^G	Gas temperature (only if temperature is measured).
ρ^G	Gas density.
Δp^G	Delta pressure at orifice in differential pressure device (only if differential pressure device was chosen).

10.4.4 Differential pressure device

If in the wizard differential pressure device was declared, then in installation menu **Diff pres device for Δp** submenu is set automatically. Parameters for this device should be entered here. If two differential pressure devices were chosen, one on supply and the second on return pipeline, two such submenus are set.

The flow computer can calculate flowrate for differential pressure devices according to:

- ILVA or Gilflo characteristic.
- Orifice PN EN ISO 5167 standard (only for steam and water).
- Orifice approximated characteristic with square root curve.

ILVA characteristic requires entering coefficients Max. F and V, W, X, Y, Z. The correct tube diameter has to be chosen from the list. Gilflo characteristic requires entering coefficients Max. F and A, B, C, D, E. The proper Δp range is forced in settings, 0 to 498.18 mbar for ILVA and 0 to 348.72 mbar for Gilflo. But the Δp range can be changed by user, if required.

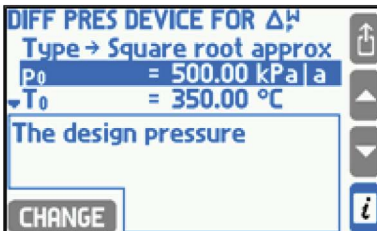
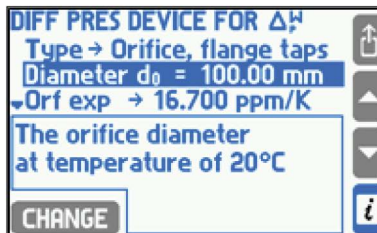
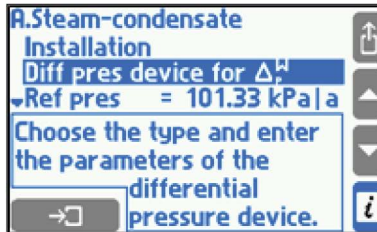

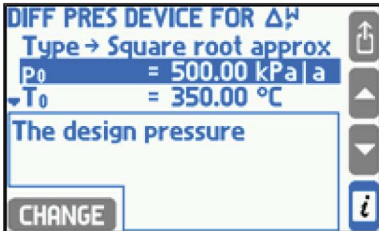
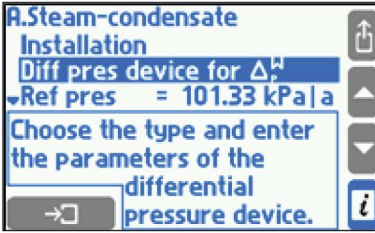

According to PN-EN ISO 5167 standard one of differential pressure devices can be chosen one of standard primary flow devices:

Orifice, flange taps	Orifice – flange tappings
Orifice, D-D/2 taps	Orifice D-D/2 pressure tappings
Orifice, corner taps	Orifice – corner tappings
ISA 1932 nozzle	ISA1932 nozzle
Long radius nozzle	Long radius nozzle
Venturi nozzle	Venturi nozzle
Venturi tube, cast	Venturi tube – cast
Venturi tube, mach	Venturi tube – machined
Venturi tube, rough	Venturi tube – rough welded sheet iron

Then the pipeline and orifice diameters as well as their temperature expansion have to be entered. Instead of entering expansion user can choose one of the following materials for pipeline and orifice:

Acid-resist steel	16.7 ppm/K
Stainless steel	10.0 ppm/K
Brass	20.0 ppm/K
Carbon steel	11.2 ppm/K
Cast iron	10.6 ppm/K
Aluminium	22.4 ppm/K

To use an approximate square root algorithm user should choose **Square root approx** in **Type** menu, then enter nominal pressure and temperature for orifice calculations and delta pressure to flowrate conversion rate.

The device can accept delta pressure transmitters with both linear and square root characteristic (see Section 10.8). But it is recommended to apply transmitters with linear characteristic, in this case extraction of square root is calculated in the device processor.

10.4.5 Flowrate calculation by a formula

If in application no flowmeter was installed (as its flowrate can be calculated based on other application flowrate) it is to be declared in wizard as a **Formula for q_m** . In a formula for flowrate calculation all values (including auxiliary ones) from all applications can be used but the result produced by formula must be mass flow.

Example: Main application A and B operate with two heat exchangers in series. In system B flow is the same thus in wizard question about flowrate measurement method is chosen **COMPUTED from the flowrates in other installations (by a formula)**. In menu Formula for q_m the following formula has to be declared: $B.q_m^W = A.q_m^W$.

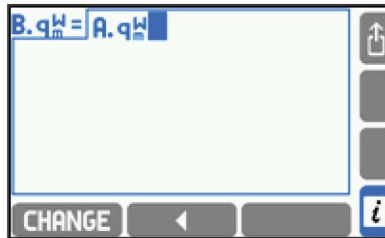
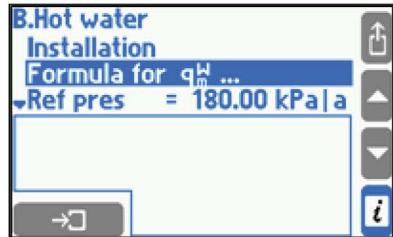
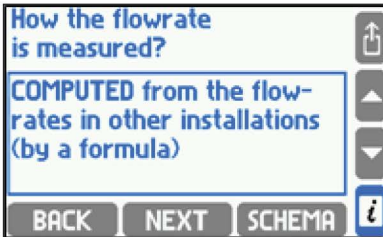

10.4.6 Superheated steam saturation detection

In installation with superheated steam there is possibility to detect saturation condition. To use this function user should choose **Yes** in **Detect** menu in Steam saturation submenu and enter minimal required margin over saturation temperature. Steam is recognized as saturated when temperature falls down below this margin. Hysteresis is always 0.5 K.

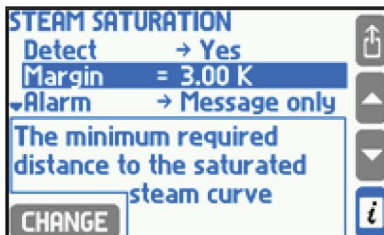
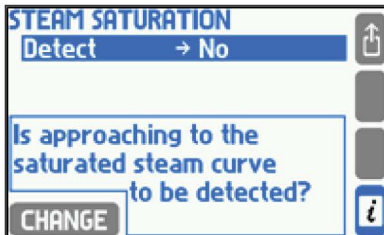
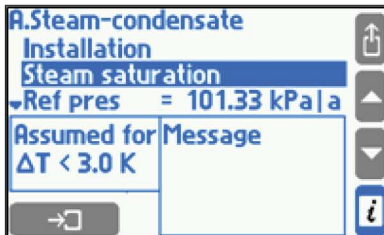

Example: Steam detection was activated and required margin was set to 3.0 K. Steam measured pressure is 1.7 Mpa – at this pressure steam gets saturated in temperature about 204.3 °C. The device will detect steam saturation when its temperature falls down below 207.3 °C (= 204.3 °C + 3.0 K). When temperature grows 0.5 K above this value i.e. to 207.8 °C (= 204.3 °C + 3.0 K + 0.5 K) the device will assume that saturation state is over.

Saturation detection results in stopping calculations and replacement values: steam density, enthalpy, flow rate and other calculated values based on them with –S– symbol. Combined totalisers also stop. Saturation condition can be announced by message on the display or can activate relay output alarm (see Section 10.7) and be recorded to event log (see Section 5.16.2). Regardless of the saturation detection a saturation alarm thresholds can be also set. It gets active when the difference between measured steam temperature and saturation temperature falls down below preset level (see Section 10.9).

If saturation detection is set to off, then the superheated steam is assumed to be even 20 °C below saturation curve.

10.4.7 Reference point for enthalpy calculation

Water and steam enthalpy is calculated according to IAPWS-IF97 standard in reference to user chosen point. The reference point is entered relevant values in **Ref press** and **Ref temp** submenus. In order to displays the enthalpy and density at the selected point **Reference properties** must be highlighted.

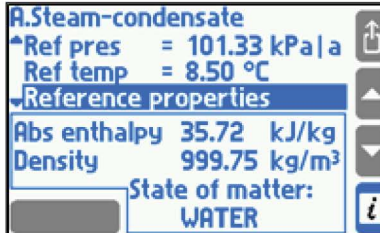

Example: As reference point 101.33 kPa and 8.5 °C was chosen. According to the standard water the enthalpy in these conditions is 35.72 kJ/kg. Measured water temperature is 78.3 °C and pressure is entered as a constant and equals 250 kPa. According to the standard water enthalpy in these conditions is 327.98 kJ/kg. Therefore calculated water enthalpy (hW) will be 292.26 kJ/kg (= 327.98 – 35.72). For installations with liquid media other than water reference point is not entered. Enthalpy is calculated only according to the entered table (see Section 10.4.1.3 - Other liquid media).

10.4.8 Saturated steam dryness fraction

For systems with saturated steam dryness fraction can be entered. It determines what percentage of medium mass is saturated steam. It is assumed that the rest consists of water at boiling temperature in form of suspension small drops. Dryness fraction influences density and enthalpy calculation, it is entered in a range between 70 to 100%. 100% value means that saturated steam is completely dry.

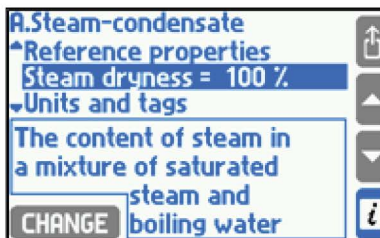

10.5 Auxiliary process values and auxiliary applications

Except of process values defined automatically in the main applications it is allowed to measure or calculate up to eight additional values in the flow computer. Those values can be displayed in the main or in auxiliary applications according to user's needs and convenience.

10.5.1 Adding and removing auxiliary values

To add, remove or edit auxiliary values user has to choose Auxiliary values submenu in the main application or in the auxiliary application menu.

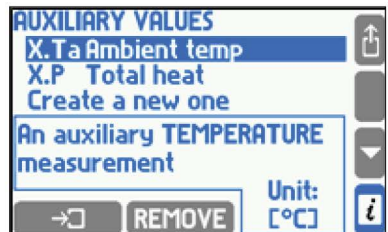
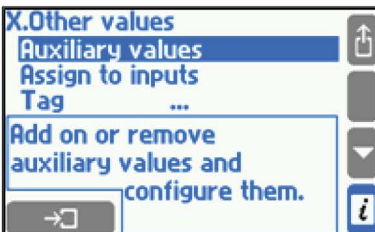
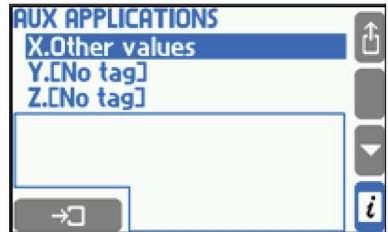
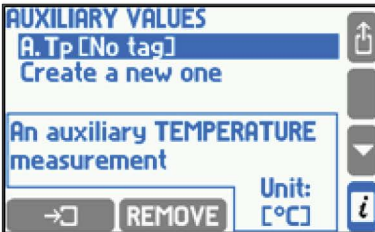
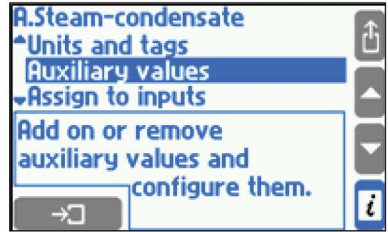
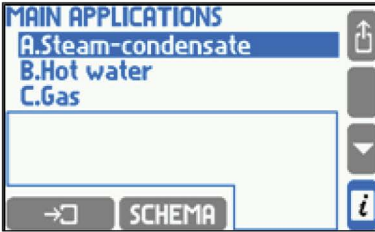

To add a new auxiliary value **Create a new** one function must be chosen and a type of the value and its symbol must be defined. A new item with the new value's setting will be added to the menu.

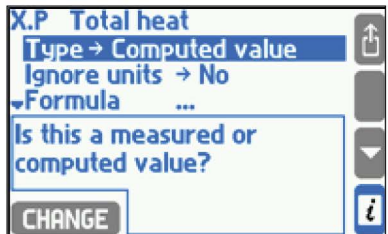
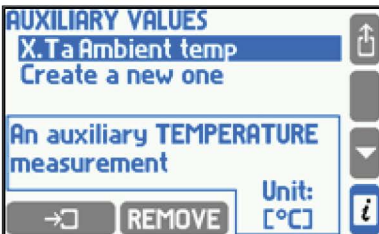
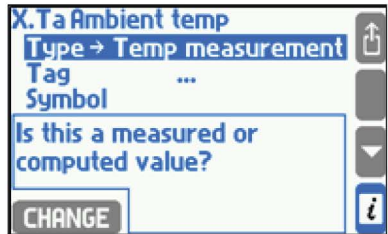
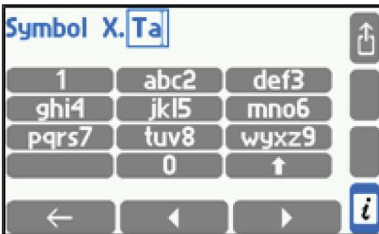
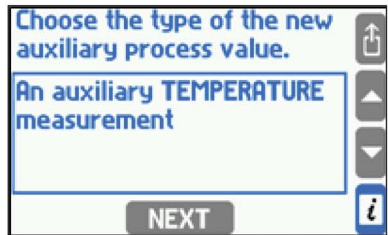
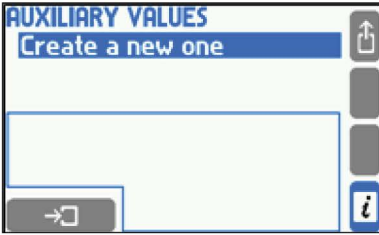

The following auxiliary values types are possible:

- An auxiliary TEMPERATURE measurement.
- An auxiliary PRESSURE measurement.
- An auxiliary measurement of ANOTHER quantity.
- A value COMPUTED by a given formula.

Once value type is set the symbol can still be changed and a tag can be entered. Other settings depend on value type and were described in Sections 10.5.2 and 10.5.3.

To remove an auxiliary value place the cursor at a given position and press **REMOVE** button.

10.5.2 Auxiliary measured values

An auxiliary value which is set as a measurement of temperature has always unit °C and does not require to enter any additional settings. Value which is set as a measurement of pressure or any other quantity requires to enter a unit. For pressure the unit can be chosen from the list (see Section 10.6) whereas for other units a text string must be entered (up to 6 characters).

An auxiliary value must be assigned to a measurement input (see Section 10.8).

Auxiliary computed values can be filtered with a digital low-pass filter with time constant chosen in the Filter submenu.



10.5.3 Auxiliary values calculated according to formulas

Each value set as computed type requires a formula to be entered. In formulas user can use symbols of other process or computed values, numerical constants, four math operations, square roots and brackets.

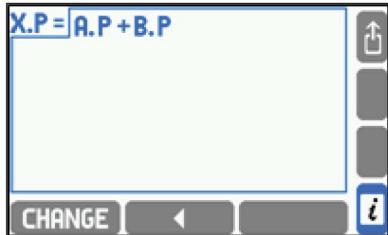
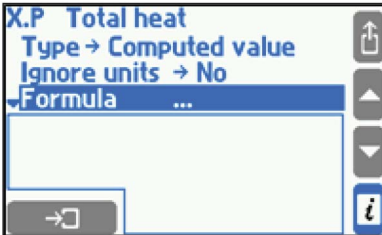

Calculations are performed taking units into account. Formula must have physical sense e.g. density cannot be added to power. Pressures and temperatures are brought to absolute values before calculations. Formula result must be one of physical quantities listed in Section 10.6 or a quantity without unit. If more than one unit is available for the result a proper unit should be taken from a Unit list.

In particular cases taking units into account can be deactivated by selecting **Yes** in **Ignore units** menu.

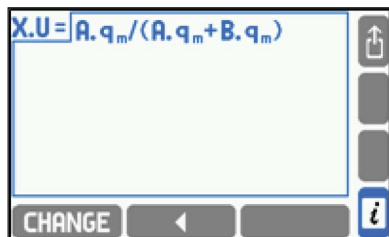

In this case a physical sense of a formula is not checked and calculations are performed exclusively for numerical values. Unit of calculated result should be written in a text form (up to 6 characters). In the mass flow rate formula units cannot be deactivated in calculations (see Section 10.5.3).

To enter or edit a formula the **CHANGE** button has to be pressed.

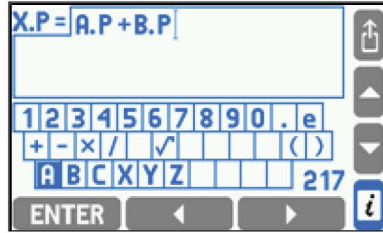
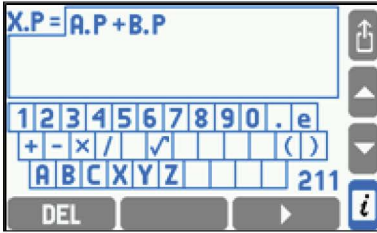

Formulas editor is similar to the tag editor (see Section 10.2.2). To enter a new process value to a formula, first, an application symbol has to be chosen from the displayed keyboard, and then a process value symbol from the next screen. Total number of used symbols in all formulas is limited, the remaining number is displayed in the right bottom corner of the screen or an extended keyboard can be used for editing formulas after pressing **CHANGE** button. When one of extended keyboard buttons is pressed the buttons meaning appears on the display. The '#' (') button allows also to enter math symbols. Usage of extended keyboard is intuitive.

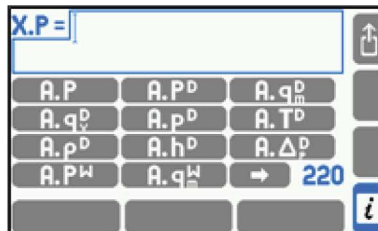
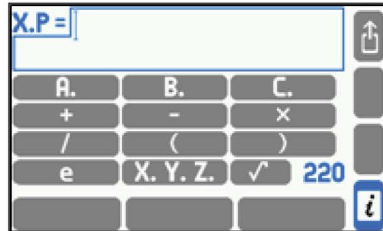
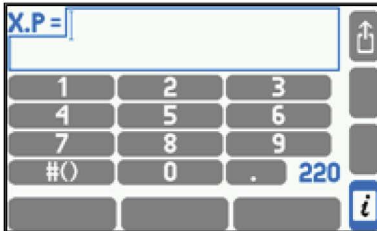
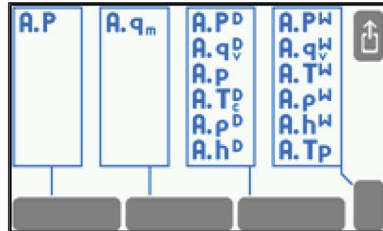

Total number of used symbols in all formulas is limited - the remaining amount of symbols to use is displayed in the bottom right corner of the screen.

10.6 Units

Each value representing any physical value and each totaliser has its own unit. There are two unit sets available in the device. Only one table can be used for parameters setting.

!

Before first parameters setting user has to choose METRIC or IMPERIAL units. To swap units sets all parameters have to be cleared to default (Function: Restore factory settings).

Only ADMIN can change units set. (ADMIN password required)

A list of the available units (Metric and Imperial) are shown in the following two tables:

Metric units (Met)									
Heat flowrate	W	kW	MW	GW	KJ/h	MJ/h	GJ/h	J/m	KJ/m
	MJ/m	GJ/m							
Heat energy	kJ	MJ	GJ	kWh	MWh				
Mass flow	g/s	kg/s	kg/h	t/h	g/m	kg/m	t/m		
Mass	g	kg	t						
Volumetric flow	cm ³ /s	dm ³ /s	m ³ /s	l/s	cm ³ /h	dm ³ /h	m ³ /h	l/h	cm ³ /m
	dm ³ /m	m ³ /m	l/m						
Volume	cm ³	dm ³	m ³	l					
Volum. flow (gases)	Ndm ³ /s	Nm ³ /s	NI/s	Ndm ³ /h	Nm ³ /h	NI/h	Ndm ³ /m	Nm ³ /m	NI/m
Volume (gases)	Ndm ³	Nm ³	NI						
Pressure	kPa a	MPa a	bar a	ksc a	kPa g	MPa g	bar g	ksc g	
Pressure difference	Pa	kPa	MPa	mbar	bar	ksc	inAq		
Temperature	°C	K							
Temp. difference	°C	K							
Enthalpy	kJ/kg								
Density	kg/m ³	g/cm ³							
Specific volume	m ³ /kg								
Coefficient k	MJ/m ³ K								
Diameter	mm								
Temp. exp. ceof.	ppm/K								

Imperial units (Imp)									
Heat flowrate	Btu/s	kBtu/s	cal/s	kcal/s	Btu/h	kBtu/h	MBtu/h	kcal/h	Btu/m
	kBtu/m	MBtu/m	cal/s	kcal/m	Mcal/m				
Heat energy	Btu	kBtu	MBtu	kcal	Mcal	Gcal			
Mass flow	lb/s	lb/h	ton/h	Btu/m	kBtu/m	MBtu/m	cal/s	kcal/m	Mcal/m
Mass	lb	ton							
Volumetric flow	in ³ /s	ft ³ /s	gal/s	dbbl/s	in ³ /h	ft ³ /h	gal/h	dbbl/h	in ³ /m
	ft ³ /m	gal/m	dbbl/h						
Volume	in ³	ft ³	gal	dbbl					
Volum. flow (gases)	scf/s	mcf/s	scf/m	scf/h	mcf/h				
Volume (gases)	scf	mcf							
Pressure	psi a	Torr a	atm a	psi g	Torr g	atm g			
Pressure difference	psi	Torr	atm	inAq					
Temperature	°F	°R							
Temperature difference	°F	°R							
Enthalpy	Btu/lb								
Density	lb/ft ³								
Specific volume	ft ³ /lb								
Coefficient k	Btu/ft ³ R								
Diameter	in								
Temp. exp. ceof.	ppm/°F								

Table meanings are shown on the next page

l	= lt (liter)
ton	= Short ton
gal	= US gallon
dbbl	= Dry barrel
ksc	= kgf/cm ² = kG/cm ² = 98.066 5 kPa
torr	= mm Hg
scf	= Standard cubic feet (typically at 60 °F and 14.73 psi; may be also programmed to other reference)
mcf	= Thousand standard cubic feet
Btu	= 1 055.056 J (ISO 31-4)
cal	= 4.184 J (ISO 31-4)
lb	= 0.453 592 37 kg
ton	= 907.184 74 kg
ft	= 0.304 8 m
in	= 0.025 4 m
gal	= 0.003 785 412 m ³
dbbl	= 0.115 627 1 m ³
lbf	= 4.448 221 615 N
kg/cm ²	= 98 066.5 Pa
atm	= 101 325.0 Pa
torr	= 133.322 4 Pa
inAq	= 248.84 Pa (at 60 °F)

Pressure may be displayed in absolute pressure (ended with 'a') or in gauge pressure (ended with 'g') which refers to an average atmospheric pressure. The value of average atmospheric pressure in the area of the device should be entered in settings – Barom pres. submenu.

For additional values also any unit may be entered in text form (up to 6 signs) but then the device will not understand its meaning and will not be able to recalculate it. An additional value without entered unit is treated as a quantity without a unit.

10.7 Relay outputs and event messages

The flow computer has four output relays named RL1...RL4. To be able to use these outputs they should be configured before entering other settings. Otherwise it will not be possible to assign them to events or totalisers when further settings are entered. However, if output relays are not dedicated for operation they should be left deactivated.

10.7.1 Outputs activating events

Relay outputs can react to the following events:

- Alarm and control threshold over crossing.
- Saturation of superheated steam.
- 4 - 20 mA transmitter or RTD sensor failure or disconnection.
- Close or open of binary input (in State mode operating).

If output should react to a selected event it must be assigned to this event in relevant settings. These are respectively: settings of alarm/control threshold, settings of measurement system (submenu Steam saturation) and settings of measurements inputs (submenus Actions when failure, Actions when closed and Actions when open). Each output can be assigned to any number of events. An output becomes active in case of occurrence of at least one of events it was assigned to. However to be able to assign an output relay to events it should be earlier activated by selection of one of two operation modes.

10.7.2 Control and alarm mode

Each output can operate in control or alarm mode. If it is deactivated or in pulse mode, it is hidden on the output relays screen and it cannot be assigned to events.

Relay output set to a control mode (non-latched) becomes active for a time of an event to which it was assigned. Relay output returns to his normal state when all events end.

Output set into alarm mode (latched) becomes active when one of assigned events occur. Simultaneously a message about the event is displayed and red ALARM diode starts pulsing.

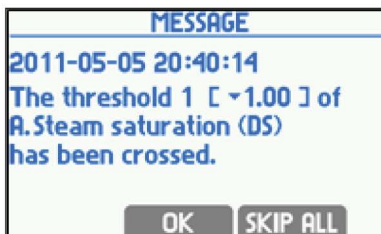
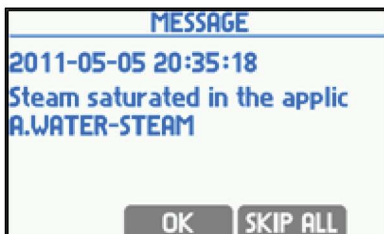
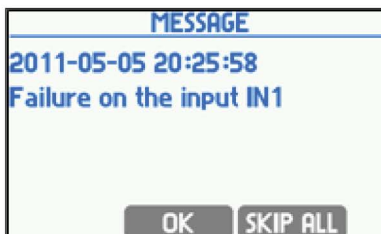

After confirming the message (by pressing **OK** button) the output becomes deactivated. Red ALARM diode stops pulsing but it remains on until the event disappears. If another event occurs before confirmation of the previous message then its message is displayed after confirmation of the previous one even if the new event itself disappeared to that moment. The output becomes deactivated after confirmation of the last waiting message. **SKIP ALL** button is used to confirm all waiting messages at one time.

10.7.3 Relay outputs assignment and alarm message activation

To assign a relay output to a selected event user has to choose Alarm or Control item from the menu.

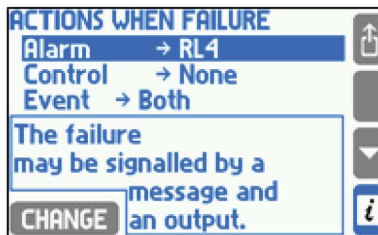
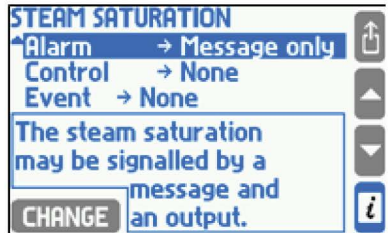
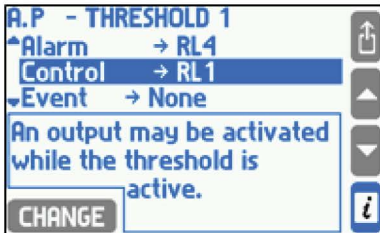

On the selection lists are available only outputs set into proper mode (alarm or control mode). In **Alarm** menu user can choose **Message** only, without relay output assignment. In this case an event will be signaled only by a message and ALARM diode on the front panel and no relay output will become active.

10.7.4 Relay outputs configuration

To configure a relay output (i.e. to set its operation mode and active state) user should select **Relay outputs** from the settings menu and then select corresponding output in the subsequent submenus.

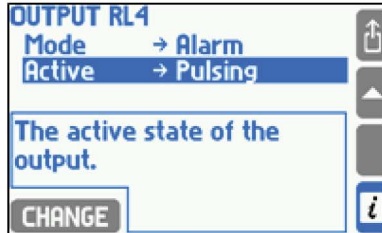
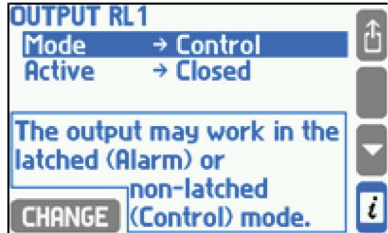
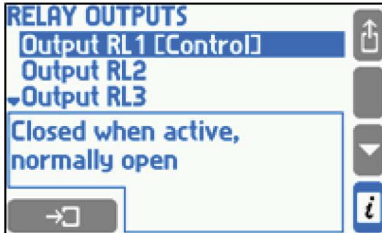

An active state may be closing, opening or pulsing (for alarm mode).

10.7.5 Pulse mode and assigning totaliser

If relay mode is set to pulse, then one of the available totalisers can be assigned to it. But first the totalisers have to be declared and configured. The pulse output can generate up to 10 pulses every second (50 msec pulse width). If the calculated number of pulses is greater, then surplus amount is buffered and generated in following periods. To prevent buffer overflow the proper multiplier has to be set. If the totaliser decreases its amount, the pulses are not generated. The buffer algorithm tries to keep the number of pulses corresponding to totaliser value. If the power is switched off, the buffer is reseted.

Mode impulse counter and an assignment if the relay mode is set to pulse dialing, you can assign one to the list of available counters (e.g., movement, or energy). This means that you must first define the performance counter. The output can generate up to 100 pulses within 1 s, if the quantity of pulses is greater, this exceeding amount is buffered and generated in seconds. Therefore, you must select the correct weight of the pulse. If the counter decreases its value, the signals are not generated. Action cache tends to generate a number of signals to match the numerator. If you disable power buffer is reset to 0.

10.8 Measuring inputs

10.8.1 Process values assignment to measuring inputs

Each process values must be assigned to measuring input. For this purpose an assignment table in settings menu is used. It is accessed in submenu **Inputs**, in **Assign** submenu. The assignment table can be also accessed from the main application or an auxiliary application menu (**Assign to inputs**), but in this case only process values for this application appear in the table.

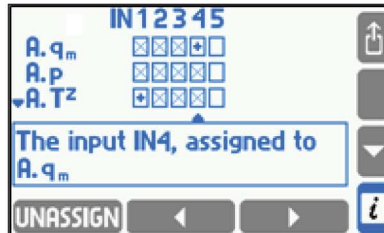
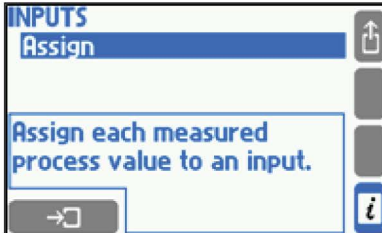

Rows in the table correspond to process values and columns to inputs. Symbol + in the check box means that a value is assigned to the input. X in the check box means that the assignment is impossible. To change the assignment state user has to place a cursor on the check box using arrows buttons and press **ASSIGN** or **UNASSIGN** button.

More than one temperature value or pressure value can be assigned to the same input. But they must be values from different applications and must have the same unit. Assigned inputs have to be configured using **INPUTS** submenu. Unassigned inputs are not accessible in this menu and cannot be configured.

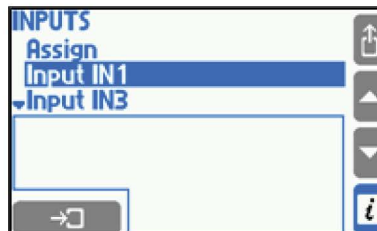

Configuration of different input types is described in the following Sections.

10.8.2 Measuring inputs

The flow computer has 12 inputs:

- **6 x I (IN1, IN2, IN3, IN4, IN5, IN6)**
Inputs for 0/4-20 mA current loop general purpose sensor.
- **3 x RTD (IN7, IN8, IN9)**
Inputs for 2- or 4- wire RTD temperature sensors (like Pt100 .. Pt1000).
- **3 x PULS (IN10, IN11, IN12)**
Inputs for pulse, frequency or binary state sensor
(OC transistor, passive contacts or voltage source sensor).

10.8.3 Current 4-20 mA and 0-20 mA inputs

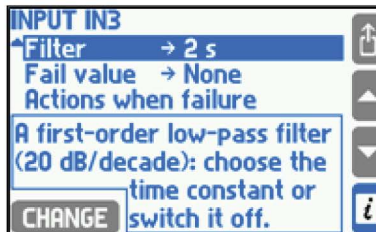
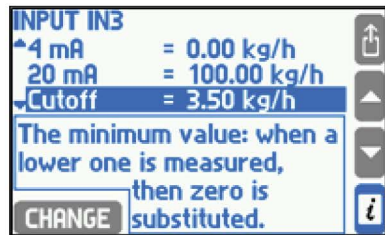
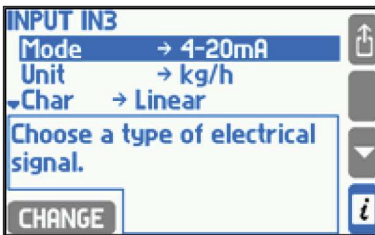

Transmitters with analog current loop signal 4-20 mA or 0-20 mA can be connected to a current input (I type). Signal type can be set in **Mode** submenu. Dependence between measured quantity and current signal is selected in **Char** submenu. It may be **Linear**, square root (Transm $\sqrt{\Delta p}$ - only for differential pressure sensors) or any other characteristic defined by user (see Section 10.8.6). Square root curve is available only for differential pressure measurements and it means that output current signal is proportional to square root of measured value. If linear or square root transmitter characteristic was chosen then the signal range has to be entered for 0/4 mA and 20 mA. Entered here resolution (number of decimal digits) does not influence on a displayed resolution which is selected in the display settings (see Section 10.16.2).

A range is entered in a unit assignment to the input. However range of pressure transmitters can be entered in absolute or gauge units independently from displayed unit. Unit of this range depends on selection made in Transmitter submenu. It is recommended to set up gauge units for gauge pressure transmitter and absolute units for absolute pressure transmitter.

Measured value can be filtered with a digital one-pole low-pass filter with time constant chosen in Filter submenu. Additionally for values other than temperature and pressure cutoff can be activated. In this case if measured value is lower than cutoff value it will be replaced by zero.

Current higher than 22 mA or lower than 3.6 mA (for 4 - 20 mA signal) is interpreted as a measurement sensor failure and the value is displayed together with symbol –E– (over 22 mA) or –||– (less than 3.6 mA) as the same to all other values calculated on its base. Failed measured value can be replaced by an emergency value (the last correctly measured value or a constant value set in Emerg submenu). Failure can be reported with a message on the display or with a relay output alarm (see Section 10.7) and can be also recorded in the event log (see Section 5.16.2).

If a GSM module is connected to the RS-485 port, failure notifications can be sent as a text message (see Section 10.15). Appropriate settings are configured in submenu '**Action when failure**'.

10.8.4 RTD inputs configuration

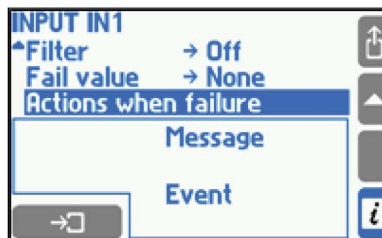
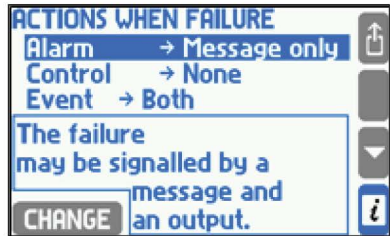
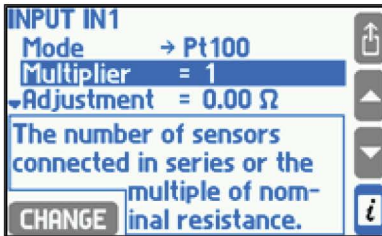

Platinum (Pt100 to Pt1000) or nickel (Ni100 to Ni1000) sensors can be connected to RTD inputs in 2- or 4-wire configuration. Sensor type is chosen in **Mode** submenu whereas resistance for 0 °C is determined by selection in **Multiplier**, where value 1 designates Pt100 or Ni100, value 2 – Pt200 or Ni200 etc. In **Adjustment** submenu wires resistance can be entered to correct the temperature computation mainly for 2-wire connection. To correct sensor error a negative value of wires resistance can be entered.

Measured temperature can be filtered with a digital single-pole low-pass filter with time constant chosen in Filter submenu.

Pt100 sensor can work in the range between -200...850 °C that corresponding to the resistance range of 18.52...390.48 Ω, whereas Ni100 sensor can work in the range between -60...250 °C that corresponding to resistance between 69.5...289.2 Ω. Value which is out of the range is treated as a sensor failure and is displayed together with symbol –F– (failure) as the same to all other values calculated on its base. Failed measured value can be replaced by an emergency value (the last correctly measured value or a constant value set in Emerg submenu). Failure can be reported with a message on the display or with a relay output alarm (see Section 10.7) and can be also recorded in the event log (see Section 5.16.2) depending on settings in Actions when failure submenu. When choosing the emergency value as the last result the filter time constant should be set as big as possible for the application.

If a GSM module is connected to the RS-485 port, failure notifications can be sent as a text message (see Section 10.15). Appropriate settings are configured in submenu '**Action when failure**'.

10.8.5 Configuration of binary PULS type inputs

Digital inputs can operate in one of three modes: frequency measurement, pulse counting or state monitoring.

10.8.5.1 Frequency measurement

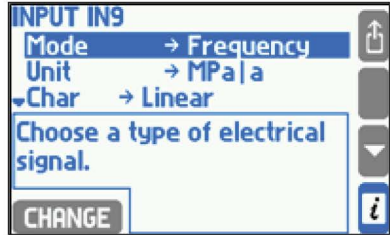
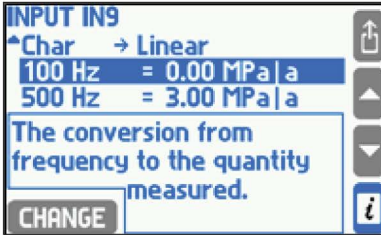

Measuring transmitters with frequency output in the range between 0.001 Hz ...10 kHz can be connected to the binary inputs operating in a frequency measurement mode. Dependence between measured quantity and frequency signal is selected in **Char** submenu. It may be Linear, square root (**Transm** $\sqrt{\Delta p}$) or any other user defined characteristic (see Section 10.8.6). Square root curve is available only for delta pressure transmitter and it means that output frequency value is proportional to square root of the measured value. If linear or square root transmitter characteristic is chosen then the lower and upper frequency range has to be entered. Entered resolution (number of decimal digits) does not influence on displayed resolution which is selected in the display settings (see Section 10.16.2).

For physical quantities other than temperature and pressure user can activate **Cutoff**. In this case if measured value is lower than the cutoff value it is replaced by zero.

10.8.5.2 Pulse counting

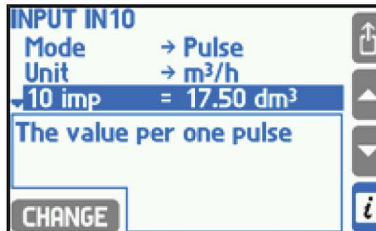

Pulse counting is chosen if a flowmeter with a constant pulse value is connected to the binary input. The pulse value should be entered giving a flow value corresponding to the relevant number of pulses. Flowrate value is computed based on measured frequency while the main ($\Sigma 1$) and additional ($\Sigma 2$) totalisers count input pulses multiplied by entered pulse value. In this way no pulse is lost even if a cutoff value is set for flowrate.

User can activate **Cutoff**. In this case if measured value is lower than the cutoff value it is replaced by zero.

10.8.5.3 State monitoring

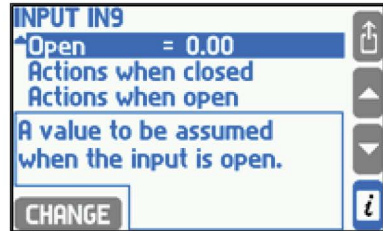
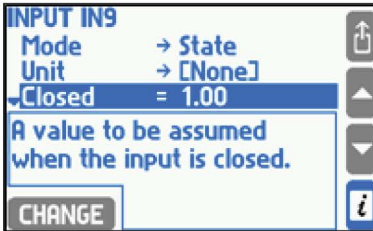

A process value assigned to the binary input in the state monitoring mode may have two values: one, when the input is closed and the other when it is opened (e.g. input closed equals -6.25, and opened +12.5). Both values can be entered in settings. This mode is available only for the inputs with auxiliary values assigned and can be used for indication of flow direction, as a multiplying factor in sophisticated applications.

Both closed and open state can be indicated with a message on the display or as a relay output alarm (see Section 10.7), also can be recorded in the event log (see Section 5.16.2) and it can be used to switch over to second archive speed (see Section 10.12.2). Adequate settings are entered in **Actions when closed** and **Actions when open** submenus.

10.8.6 Nonlinear characteristics of measurement transmitters

The flow computer can also accept the current loop or frequency signal other than linear or square root. Transmitter's characteristic is upload to the device as a file. Such file should be prepared on a PC computer in a text editor or in a spreadsheet and copied to the USB Flash Memory (pendrive). Accepted extensions are .txt and .csv. An example of the file contents with the transmitter's characteristic with frequency signal is given below.

```
#char Nonlinear
100.0 30.0
200.0 40.0
300.0 52.0
```

A file must begin with string #char which is followed by the name (up to 12 characters, here Nonlinear). In the next line the table starts with two columns of numbers: transmitter signal in Hz (or mA for current loop transmitter) and corresponding measured value. The table must be ordered in sequence of growing signal values. In the example value 30.0 corresponds to 100 Hz frequency. Values between the table points are linearly interpolated (here in the example 35.0 corresponds to frequency 150 Hz). Values outside the table are linearly extrapolated (here in the example 25.0 corresponds to 50 Hz, and 64.0 to 400 Hz).

Transmitter's characteristics are stored in the data base in the settings. To view the base contents and to add or remove characteristic table user has to choose Characteristic manager submenu from the main menu.

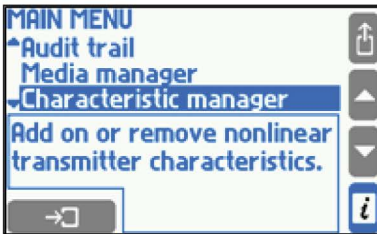

To add on a new characteristic the USB Flash Memory containing a relevant file has to be inserted. In Characteristic manager menu user has to press **NEW ONE** button. A list of files with .txt or .csv. extensions will be displayed and the highlighted file can be chosen with the **LOAD** button. A new characteristic can also be added during the input configuration without need of entering the characteristic database. For this purpose in **Char** submenu user should choose **From file...** This will display a list of available files and it allows to add a characteristic table.

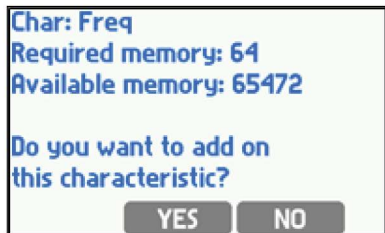

Pressing **REMOVE** button deletes all media (see Section 10.4.1.3 - Other liquid media) and all user's characteristics. The occupied memory volume is displayed next to the name on the list of characteristic tables. At the bottom of the screen the remaining free memory space is displayed. The database can store up to 16 characteristics.

10.9 Alarm and control thresholds

For each process value except of density (ρ), enthalpy (h), differential pressure (Δp) and water thermal coefficient (k) up to four alarm and control thresholds can be set. It is configurable in the settings menu in **Alarms and control** submenu.

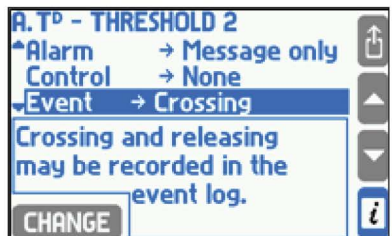
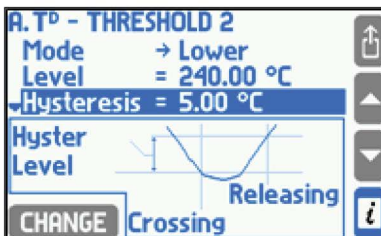
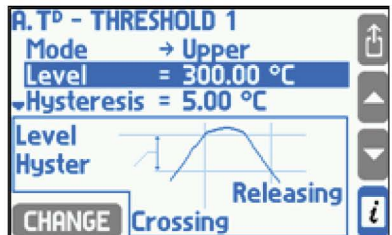
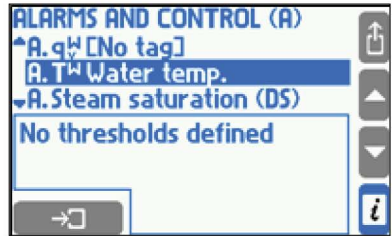
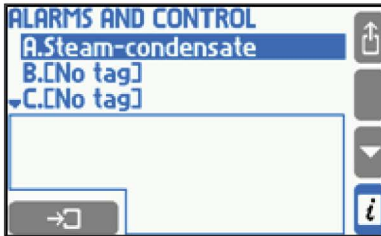

To activate a threshold the first has to be selected the mode (Upper or Lower), and then the threshold value and the hysteresis value. Upper threshold activates when the value exceeds the threshold level and releases when the value declines below that level by at least as much as hysteresis. Lower threshold activates when the value declines below the level and releases when the value exceeds that level by at least as much as hysteresis.

In systems with superheated steam, thresholds may be set to a process value called **Steam saturation (DS)**. This special thresholds activates when difference between measured steam temperature and saturation temperature at measured pressure is below the set level. It is used to indicate when superheated steam conditions are too close to its saturation.

Exceedance a threshold can be signaled with a text message on the display or with the relay output alarm (see Section 10.7), it is reported in the event log (see Section 5.16.2) and may switch over to the second archiving speed (see Section 10.12.1). Crossing a threshold is also signaled with a change of a color of the displayed value.

Information about exceedance of thresholds is displayed on the screen called the alarm and control thresholds (see Section 5.3.2). A displayed symbol ▲ means crossing of an upper threshold while a symbol ▼ means crossing of a lower threshold. A shaded square means that a respective threshold is not defined.

10.10 Totalisers

For process values of flowrate or heat flowrate and for additional values which unit end with /h, /min or /s. Up to four totalisers can be set:

- Main totaliser ($\Sigma 1$).
- Auxiliary totaliser ($\Sigma 2$).
- Overage or hourly totaliser (the ordered power) (ΣH).
- Underrange totaliser (ΣL).

In the settings menu in Totalisers submenu user can set up totalisers for all active main and auxiliary applications.

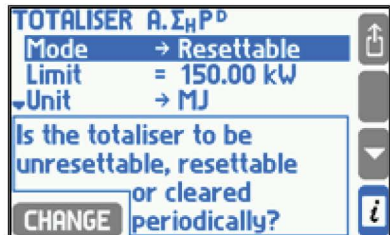
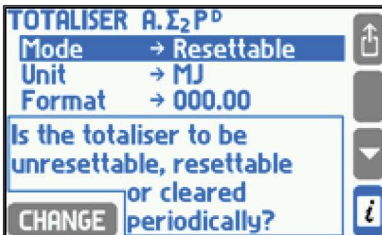
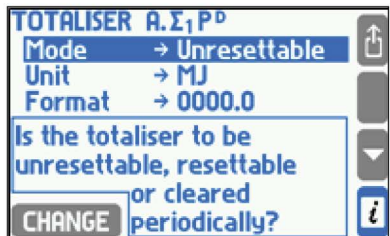

The main $\Sigma 1$ and the auxiliary $\Sigma 2$ totaliser add flowrate or heat values in one second periods. An exception is when process value is assigned to binary input operating in pulse counting mode. Then totalisers count pulses multiplied by their values.

Example 1: Flowrate value is 1800 kg/h. Each second 0.5 kg ($= 1800 \text{ kg/h} / 3600 \text{ s} \times 1 \text{ s}$) is added to main and auxiliary totaliser.

Example 2. Volumetric flowrate is measured with pulse flowmeter where 1 pulse = 10 dm³. The flowmeter is connected to the binary input and set to pulse counting mode. The flowmeter rotates with a speed of 1 pulse every 20 seconds (frequency is 0.05 Hz). Therefore the flowrate is 0.5 dm³/s. However the main and auxiliary totalisers do not totalise flow 0.5 dm³ every second. They increase their value by 10 dm³ every 20 seconds when a pulse comes.

The overrange totalizer ΣH totalises only amount over a set limit. If the value is lower than the limit the totaliser stops.

Example. An overrange totaliser was activated for heat flowrate and a limit was set to 150 kW. Heat flowrate value is 162 kW.

Each second a value of 12 kJ ($= [162 \text{ kW} - 150 \text{ kW}] \times 1 \text{ s}$) is totalised.

An underrange ΣL totaliser totalises only amount under a set limit. If the value is higher than the limit the totaliser stops.

Example. An underrange totaliser is activated for heat flowrate and a limit was set to 20 kW. Heat flowrate value is 17 kW. Each second a value of 3 kJ ($= [20 \text{ kW} - 17 \text{ kW}] \times 1 \text{ s}$) is totalised.

A totaliser may operate in one of the following modes:

- Unresettable
- Resettable (this mode cannot be used for main totaliser)
- Hourly
- Daily
- Monthly

An unresettable totaliser operates constantly from the moment of its activation in settings. It cannot be reset from keyboard neither it is reset automatically. A resettable totaliser can be reset from keyboard on a totaliser screen (see Section 5.3.2). Resetting can be executed for only one totaliser or for all resettable totalisers at once. An hourly, daily and monthly totaliser resets periodically:

- Hourly - resets totaliser at full hours.
- Daily - resets totaliser once a day at any full hour selected in **Hour** submenu in settings

Nominal month beginning menu.

- Monthly - resets totaliser at any day of a month between 1st and 28th or on the last day of the month (Day submenu in settings **Nominal month beginning** menu) at any full hour like daily reset totaliser.

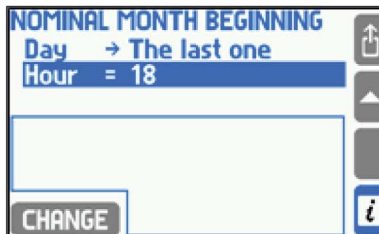
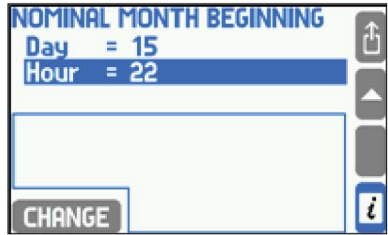
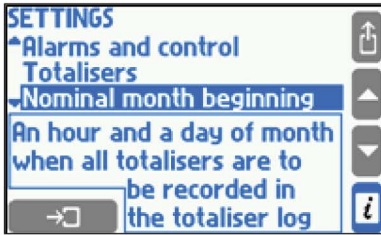

Each totaliser has its own unit. Energy, mass and volume unit can be selected from a list according to the table in Section 10.6. A unit change causes a relevant rescaling of the totalised value. The totaliser value can be displayed with resolution from 0 to 4 decimal digits. The resolution does not influence on the accuracy of the totaliser and can be changed at any time.

Values of all active totalisers are recorded into a totaliser log at the end of each month according to settings in **Nominal month beginning** submenu (see Section 5.16.1). Additionally, values of some user chosen totalisers may be recorded into hourly archive file in the internal memory at every full hour (see Section 10.12.2).

An operator with service privileges can set the timers on any of the major initial values and reset all the other counters, including those that are not erasable.

10.11 4 - 20 mA current loop output (optional)

The flow computer may be optionally equipped with one or two 4-20 mA current loop output, (see Section 3.3). An output can generate a signal proportional to one selected process value. To configure the output user has to select **4 - 20 mA Output** submenu from the settings menu.

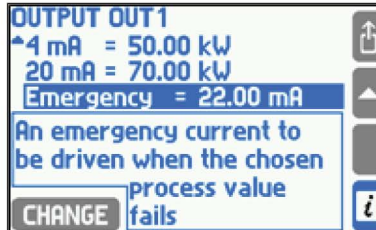
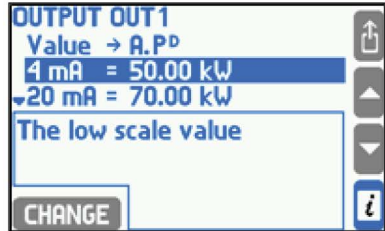
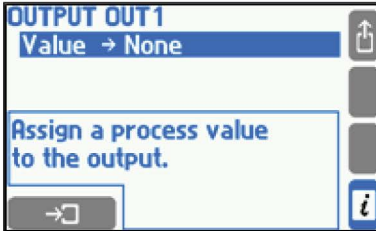

An activation of an output requires assigning selected process value from the list in Value submenu. In the next two positions are required values of extreme currents: 4 mA and 20 mA. Current signal is always in the range of 3.6...22 mA. For values smaller than 3.6 mA the output current stays at 3.6 mA. Similarly for current over 22 mA the output current stops at 22 mA.

If process value has no value (e.g. during transmitter failure when no emergency value was activated or during saturation of superheated steam), an output can generate a special current value informing about error situation. This value should be entered in Emergency submenu. If emergency value is deactivated the output current value remains unchanged if a fault is detected.

10.12 Archiving

Device has an internal memory of 2 GB in which are stored:

- Selected set of process values with the frequency chosen in the range from 3 seconds to 24 hours (see Section 10.12.1).
- Selected set of average, minimum and maximum values in the hour and totalizers (see Section 10.12.2).
- Events related to the measured objects, such as the alert and control thresholds exceedance, failures of transmitters, saturation of superheated steam, etc. (see Section 5.16.2).
- Authorised activities (see Section 5.7 and 5.16.3).

10.12.1 Main archive

Settings associated with this archive are gathered in **Main Archive** submenu.

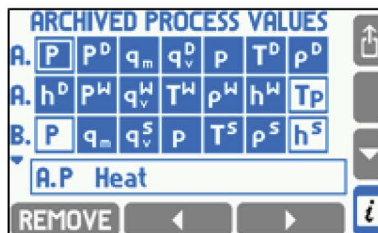
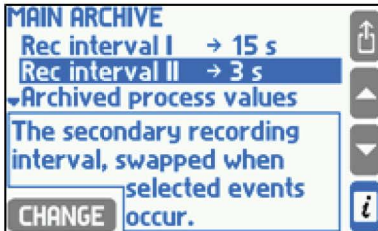

The first two menu items are to select the two archiving speeds(frequency). In normal operation the **Rec interval I** is used. **Rec interval II** may be swapped for the time of alarm and control thresholds activation or for time of closing or opening of output relays. Change of frequency of the recording by a given threshold or output relays must be declared in its setting - **Swap intervals** item.

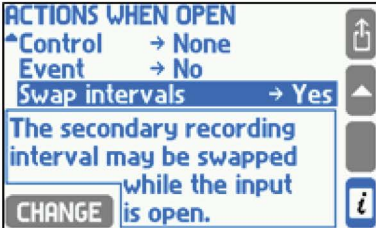
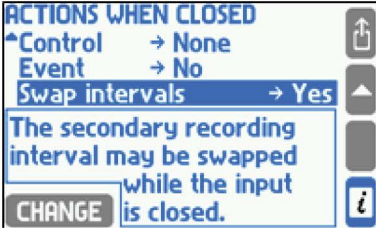
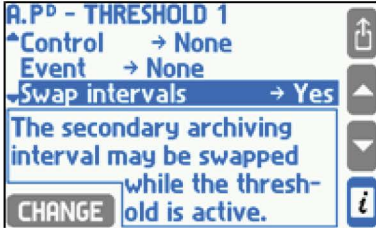

If the second archive speed is not used it is recommended to set it equal to the first one. This is important when using an archive browser in the device because the time scale is selected automatically based on both frequencies.

To determine archived set of process values user has to choose **Archived process values** submenu. A table with values of all applications will be displayed. Shaded squares mean that given process value is archived. To add on or remove value user has to place cursor on the square and press the left bottom button **ADD ON** or **REMOVE**.

Mode submenu allows to select archiving mode. **Overwrite** option means continuation of archiving by overwriting the new records on the oldest ones. One file option means that archiving will be stopped when the file size is reached. **Successive files** option allows for multiple files recording.

In **File size** submenu user can set the size of one Main Archive files from range between 2 and 256 MB or a time period (24H, Week, Month).

10.12.2 Archive of totalisers and the average values

This archive file records process values of selected totalisers (up to 15) and a set of hourly averages, minimums and maximums for chosen process values (up to 15) at full hours.

Configuration is accessed in submenu **Hourly archive** from **Settings** menu.

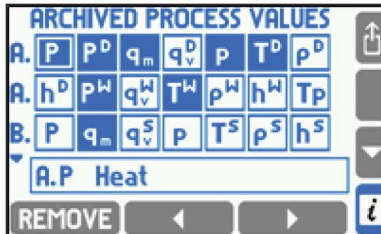
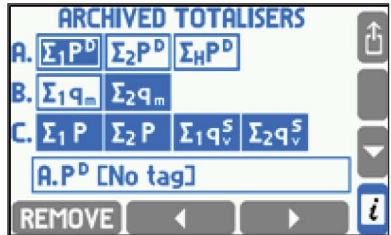

To choose a set of totalisers and process values to be archived the Archived totalisers and Archived process values submenu have to be selected from Hourly archive menu in Settings menu. After the operation a table with totalisers or process values available for all applications will be displayed. Shadowed value field means that the totaliser or value is declared for archiving. To add on or remove a value a user has to place the cursor on the check box and press the left bottom button **ADD ON** or **REMOVE**. There can be archived up to 15 totalisers and up to 15 process values at the same time.

10.13 RS-485/RS-422 serial port

Flow computer can be connected to RS-485/RS-422 network as a slave. Associated with the transmission settings are in **Serial communication** submenu in Settings menu.

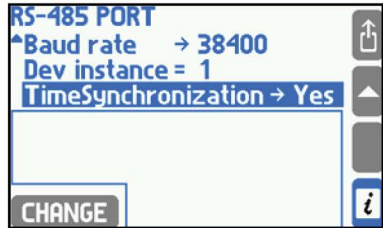
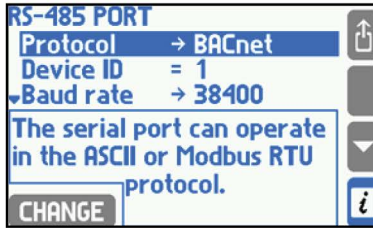
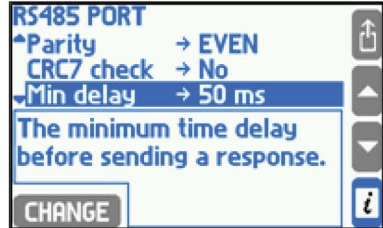
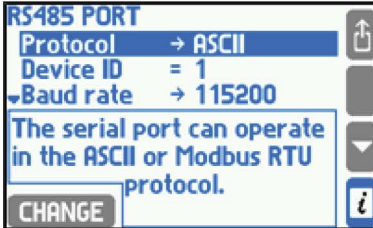

Communication can be done in three protocols (**Protocol** submenu): **ASCII**, **Modbus RTU** and **BACnet MSTP**. ASCII protocol is dedicated for communication with programs delivered by a manufacturer. Modbus RTU protocol serves for communication with universal visualization programs and enables readout of all process values and totalisers. Protocol details are described in Section 11. BACnet MSTP provides a data communication protocol for building automation and control networks.

Device ID identifies the flow computer in network and must be unique (no other device in the same network can have the same address). Baud rate and Parity must be set the same as in computer or controller which is the network master.

In ASCII protocol transmitted packages may be protected with CRC code. Device always attach a code to transmitted packages, and computer program can compute it but does not have to. When **CRC7 check** is disabled the device will not check code integrity in received packages.

In **Min delay** submenu minimum time interval between enquiry reception and answer transmission can be chosen. **Max delay** submenu applies only to ASCII protocol. If device does not manage to send an answer in the selected time then it sends a code 'not ready'.

Data read via the RS-485 has no impact on communication via the Ethernet port.

10.14 Ethernet port

A flow computer can operate in an industrial Ethernet network using Modbus TCP protocol and BACnet IP. Associated with the transmission settings are grouped together in the submenu **Ethernet Port**.

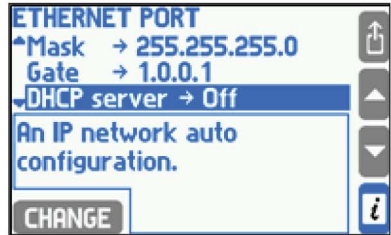
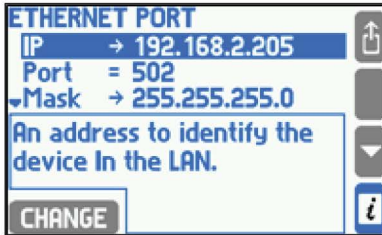

For successful communication between the device and the supervisory system all needed parameters have to be configured (menu: Settings → Ethernet port).

The factory settings are as follows:

IP: 1.0.0.1
Port: 502
Mask: 255.255.255.0
Gateway: 1.0.0.1
DHCP Server: Off
Timeout: 60 sec.

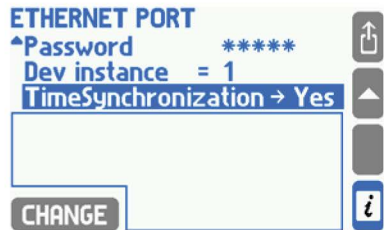

The IP address, the subnet mask and the gateway must be entered in accordance with the network, in which the device is working. In typical application DHCP server should be off. It is recommended to use port 502, because this port is dedicated to Modbus TCP. Connection timeout specifies the maximum time with no exchange of data between the client and the server. After this time the connection is automatically closed (considered inactive, for example due to an emergency off of the master unit).

Ethernet server can handle up to 4 simultaneous clients with Modbus TCP. This allows simultaneous querying the device from four different computers, or by four different systems. Data from the measurement channels are available in two formats: Integer and Floating point.

The device has also a Web Server that allows to monitor the process data using standard Web browser. To do so, the IP address (configured in the device's menu: **Settings** → **Ethernet Port**) should be entered to the browser address bar. The Web Server allows the display process values and totalisers in table format and graphic trend chart (TREND tab) and the state of output relays. Switching between the values assigned to each of the measurement application is done using the tabs A, B, C, X, Y, Z. The archive data are not available with Web Server.

On the chart, the user has the ability to set the refresh time (refresh delay are the result of delays in communication over the Internet and may vary depending on the network, from fractions of seconds to several seconds). By pressing Settings button, users can define which measuring system (and which values for a given system) is to be presented in the graph and can change the color of the trend lines.

A web server is available in six languages: English, German, French, Polish, Spanish or Portuguese.

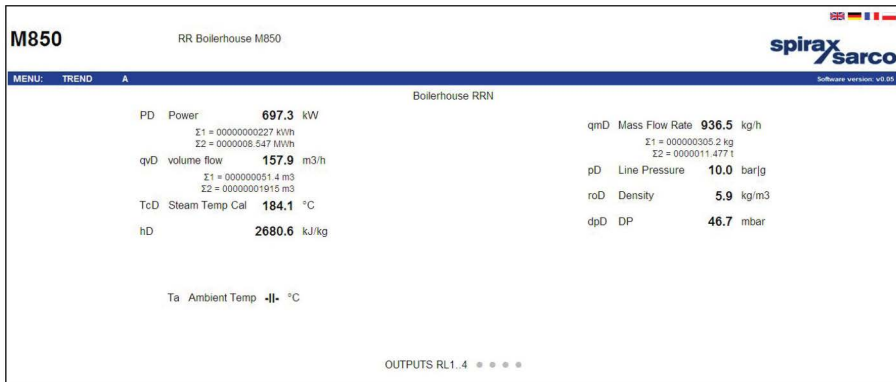

Readings sample via web server

Reading measurement data and the number of connected customers through the Ethernet port has no effect on communication via RS-485 port and vice versa.

10.15 Text messages

-  Main settings associated with sending text messages are in submenu Text messages.
→ **Main menu** → **Settings** → **Text messages**

Text messages

PIN → None/Enter... (1)

Mobile numbers (2)

Unknown numbers → No/Yes (3)

Combine → No/Yes (4)

Header → No/Yes (5)

Report (6)

Process values to be sent (7)

Totalisers to be sent (8)

Send → On request/Daily/Weekly/Monthly (9)

- (1) The PIN code should be entered only if the SIM card installed in the GSM module is protected by the PIN code.
- (2) The phone numbers list (max 3) which will be sent the notifications of alarms, failures and periodic reports.

NEW ONE - addition of the new phone number

REMOVE - deletion the item from the list

TEST - sending selected phone number (currently highlighted) a test SMS

- (3) If the option **Unknown numbers** is marked as **No**, the incoming queries from beyond the configured in the device list of phone numbers will be ignored.
- (4) If the option **Combine** is marked as **Yes** the simultaneous events will be combined in a single message.
- (5) If the option **Header** is marked as **Yes** the header, which is consist with symbol, version and description of the device, will be attached to the message.
- (6) The submenu to configure the content and frequency of sending text messages with current process values and totalisers.
- (7) In the table the arrows are used to add (**ADD ON**) and remove (**REMOVE**) chosen current process values in the sent SMS.
- (8) In the table the arrows are used to add (**ADD ON**) and remove (**REMOVE**) chosen totalisers in the sent SMS.

If the option **On request** will be chosen the reports will be sent only as a response to the request from the user (a text message with the text 'Report'). Otherwise the reports will be sent periodically, accordingly: daily (the hour which the SMS will be sent on should be specified), weekly (the hour and the day of week which the SMS will be sent on should be specified) and monthly (the hour and the day of month which the SMS will be sent on should be specified).

10.16 Display configuration

In this Section was described configuration of screens for process values while the appearance of screens and navigation rules was presented in Section 5.3. The display configuration allows to organise and present data in most convenient way for the user.

To configure the display choose Display submenu from settings menu.

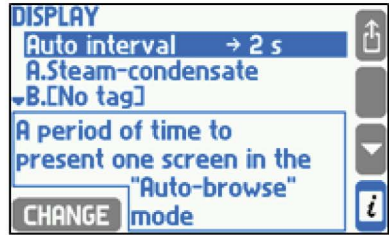
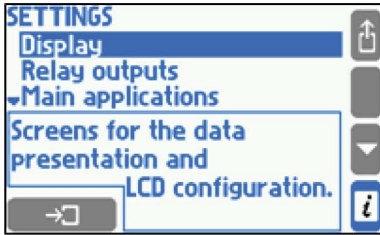

In **Auto interval** submenu time for single screen presentation during automatic scrolling is set. The last three items allow to activate or hide auxiliary screens: relay outputs screen, date and time screen and archive screen. The main screen and individual screens are set for each application separately. The last submenu item **LCD Display** allows to access the display settings menu.

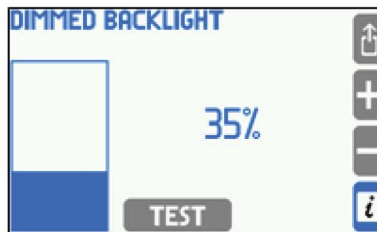
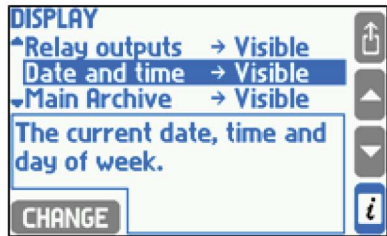

User can set the Background colour as a White or Black. The Backlight can be dimmed when keyboard is not used or can stay always on. The level of backlight can be adjusted in range of 50..100% and the dim level can also be set to 0..45%, both with step 5%. The lower backlight level saves the energy and increases the lifetime of the display.

TEST button allows to see the effect of changes in the brightness when dimmed.

To configure the main screens and the detailed screens user must first select the appropriate menu system.

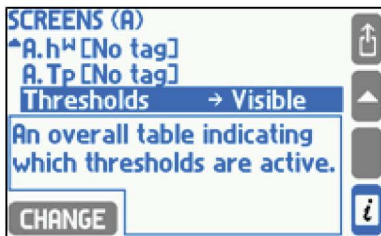
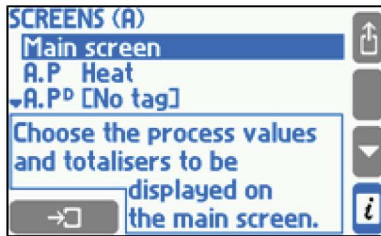
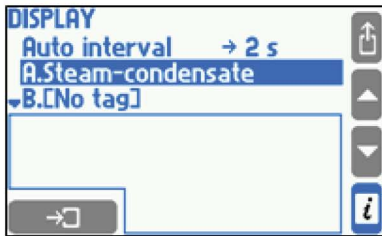

Main screen item opens the submenu where are configured the contents of the tables of the main screen of specific measuring application, see Section 10.15.1. Next menu items allow to set detailed screens for process values (resolution of displayed value, range of diagrams and bargraphs and setting visible/hide detailed screens), see Section 10.16.2. The last item **Thresholds** allows to present a thresholds screen.

10.16.1 Main screens

To configure the main screen user has to select measuring application and then **Main screen** submenu. In **Auto browse** submenu user can determine whether the main screen of chosen system should be presented during automatic scrolling. **Page 1 .. Page 4** submenus allow to configure table screens for process values.

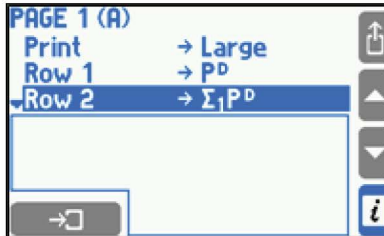
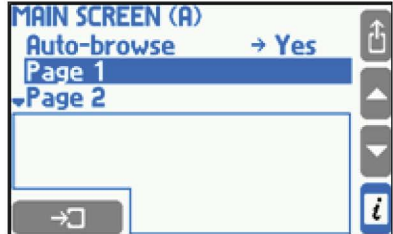
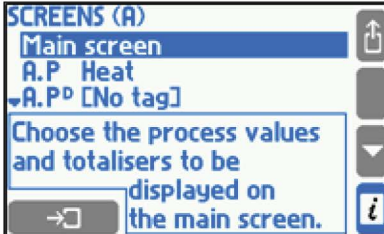

In **Print** submenu letter size may be chosen for the table – **Small** for 5 row table or **Big** – for 3 row table. **Row 1 .. Row 5** submenu allow to choose the process values or totalisers for the table rows. The selection is based on choosing from the list. If the process value has an active totalisers, then in the next step user decides which value or which of totaliser should be displayed. The same process value or totaliser can be displayed in different tables and even few times in the same table. A table is considered to be activated if at least one of its rows is not empty.

10.16.2 Individual screens, resolution and range of diagrams

Below the **Main Screen** submenu a list of all process values allows to be set for individual data presentation.

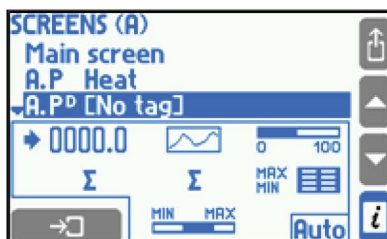
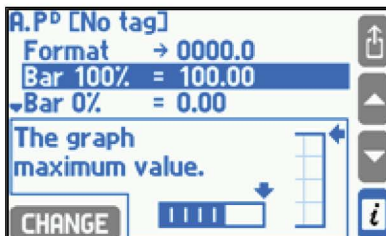
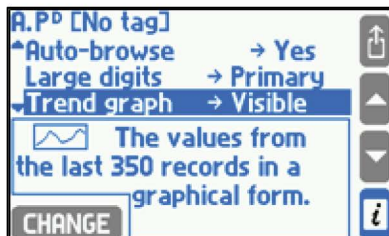

In **Format** submenu the number of decimal places of displayed and archived can be selected. A value is displayed with up to 5 digits. If all decimal places cannot be displayed they are shorted with approximation. The selected resolution does not influence on the accuracy of calculations. In **Bar 100%** and **Bar 0%** items the range of bargraph and trend screen is set.

In **Auto browse** user can determine if a given process value is to be presented during automatic scrolling. Subsequent submenu positions correspond to each available detailed screen. The totalizers positions are displayed only when the appropriate totalizer is enabled. Every process value (except density, enthalpy, pressure difference and water thermal coefficient) may be presented in form of **Large digits**, **Trend graph**, **Bar graph**, **Totalisers** (only for flow rates), **Min-Max-Avg.**, **Min-Max-Avg (bar)**. User can choose which screens are to be **Visible** and which are **Hidden**. One screen may be set to **Primary** – it means that it will always be displayed as a first one when this value is reached. If no screen is selected as default one, then a screen which was viewed as the last one will be displayed at first.

10.17 Summer and winter time - automatic adjustment

The device automatically adjusts a clock between summer time (DST - daylight saving time) and standard (winter) time. It is performed on the last Sunday of October at 3:00 and on the last Sunday of March at 2:00.

Automatic time adjustment allows to maintain continuity of archiving. In each record the date and hour are marked with a letter S (summer time) or W (winter time).

```
2006-10-29;02:00:00;S
2006-10-29;02:30:00;S
2006-10-29;02:00:00;W
2006-10-29;02:30:00;W
2006-10-29;03:00:00;W

2007-03-25;01:00:00;W
2007-03-25;01:30:00;W
2007-03-25;03:00:00;S
2007-03-25;03:30:00;S
```

In particular situations when automatic clock adjustment is not required it can be deactivated in settings - DST feature.

10.18 Saving to and loading settings from a file

Full set of settings can be saved to a file using the external USB Flash Memory (pendrive) by selecting in the main menu **Load or save settings** function and then submenu **Save**.

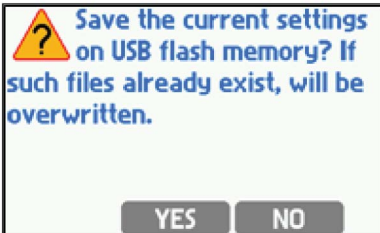
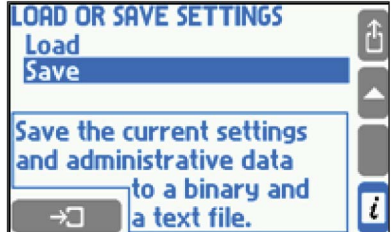
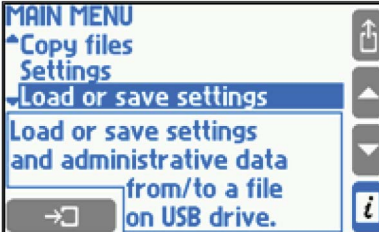

Two files (text and binary) will be created. Text file (extension .txt) allows to read settings on a PC computer using a typical text editor. Binary file (extension .set) enables to load settings to the same or the other device in the future. File name are generated automatically and contains device's RS-485 network address, e.g.: 'sett_01.txt' and 'sett_01.set'. If files with these names already exist, they are overwritten. Files names created automatically can be changed only in PC computer.

Together with settings are saved data from administrator menu about users with passwords (see Section 5.7.3) and databases for other media and user characteristics (see Section 10.4.1.3. Other liquid media). Contents of databases are saved only in a binary file.

To download settings from a file into the device user has to select Load function from menu **Load or save settings** and then choose a relevant file.

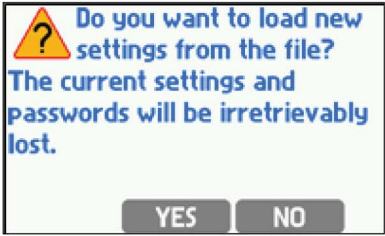
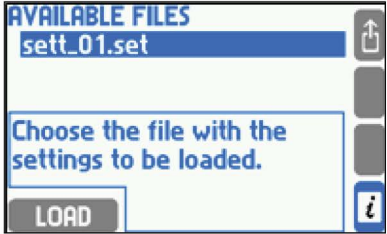
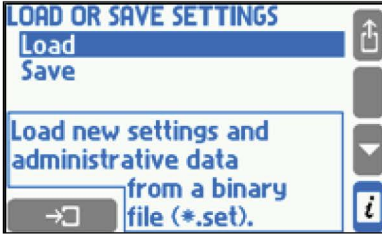

Files with extension '.set' are displayed on the list. All information from binary file will be loaded including administrator menu, passwords and databases. The previous data will be deleted irretrievably. Loading settings from a file is available only to the administrator.

Only setting from the device with the same hardware configuration may be downloaded to another device

10.19 M850 flow computer commissioning using PC software for quick start-up

The M850 flow computer can be commissioned via the key pad on the front panel of the unit itself, or via separate PC software. For quick start commissioning the PC software is used and illustrated in this manual.

The quick start commissioning assumes that the M850 will be used with either Spirax Sarco ILVA, Gilflo or M410 (Orifice plate) flowmeters that all use a differential pressure cell. The quickstart guide will show you how to set up the inputs from the DP Cell and pressure and temperature sensors as a stand-alone system only.

1. Download the commissioning software supplied with the product onto your PC.
2. 'Click' on the icon.
3. Select the language you wish the software to use (English, French, German, Spanish, Portuguese or Polish). 'Click' OK.



4. A grey screen will appear. 'Click' on File/New Settings and select either imperial or metric units.

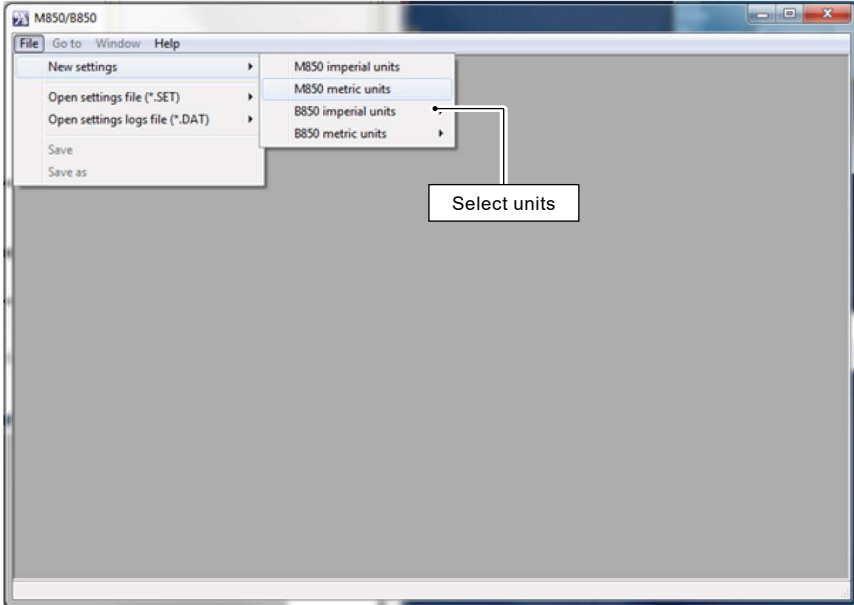

5. Type in a name that you wish to identify the flowmeter into application A, i.e. Boiler house. 'Click' on 'Configure the installation'.

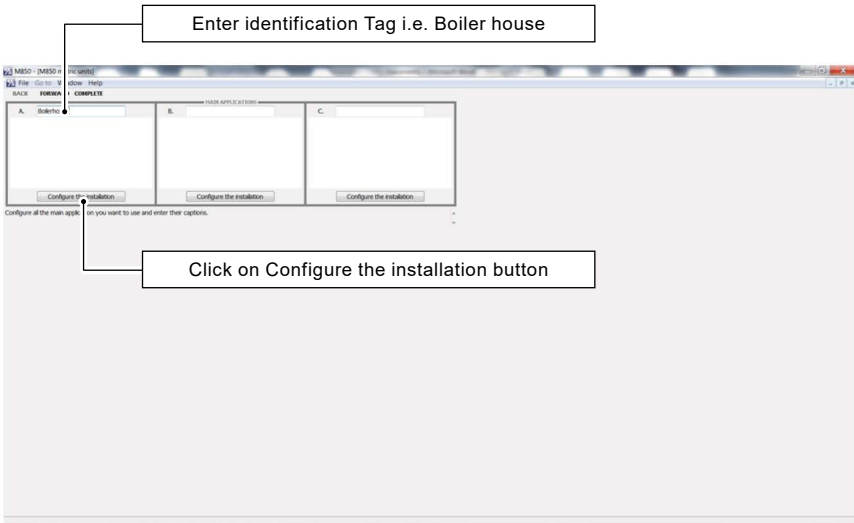

6. Select 'The flow of steam' and 'Next'.

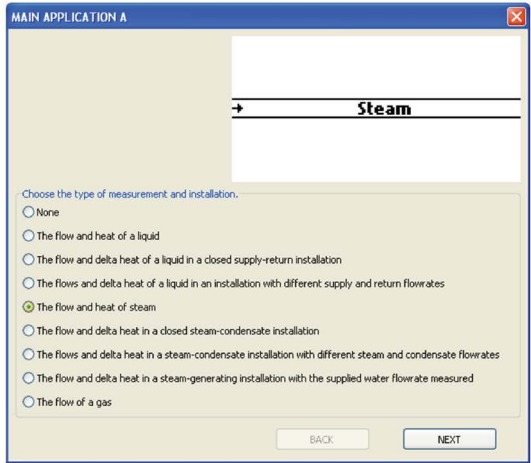

7. Select the option that you require.

To measure saturated steam either a pressure sensor or temperature sensor can be used.

If Superheated steam is being measured both pressure and temperature sensors will be required to calculate density compensation.

We have used pressure for this sample installation.

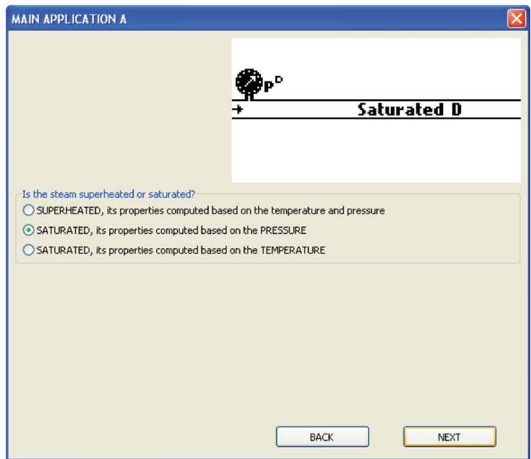

8. Select a differential pressure device and 'Click' on 'Complete'.

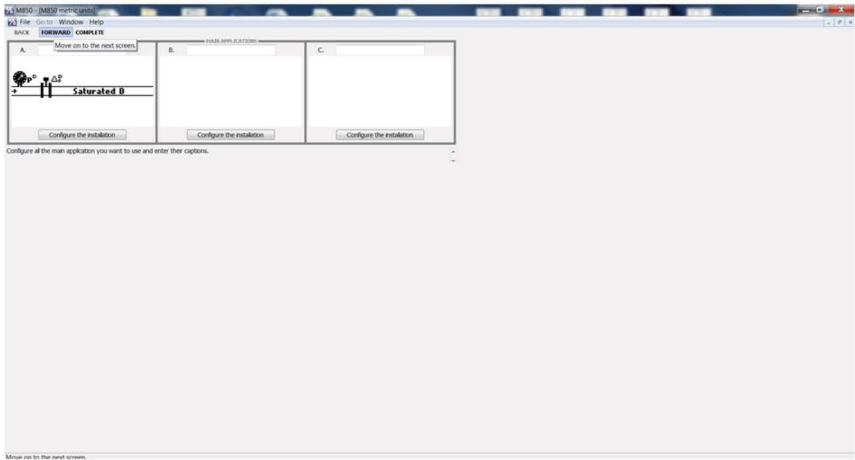
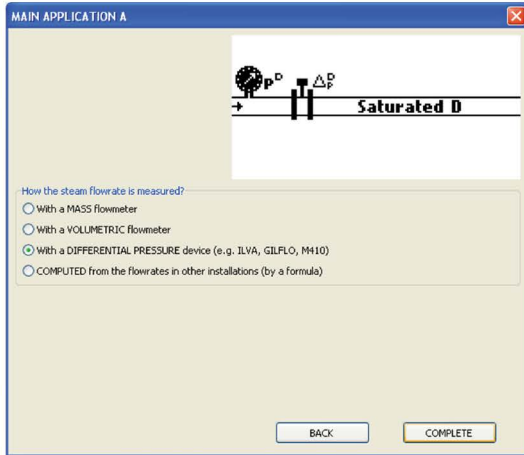

9. Forward through the next two main application screens.

10. Choose the flowmeter type and size you are using from the drop down menu (ILVA, Gilflo or Orifice flange taps (M410)). Enter the MAX F and V-Z coefficients from the flowmeter calibration certificate supplied with the flowmeter (ILVA and Gilflo). Or the information from the Orifice plate tab. 'Click' Forward.

ILVA/Gilflo

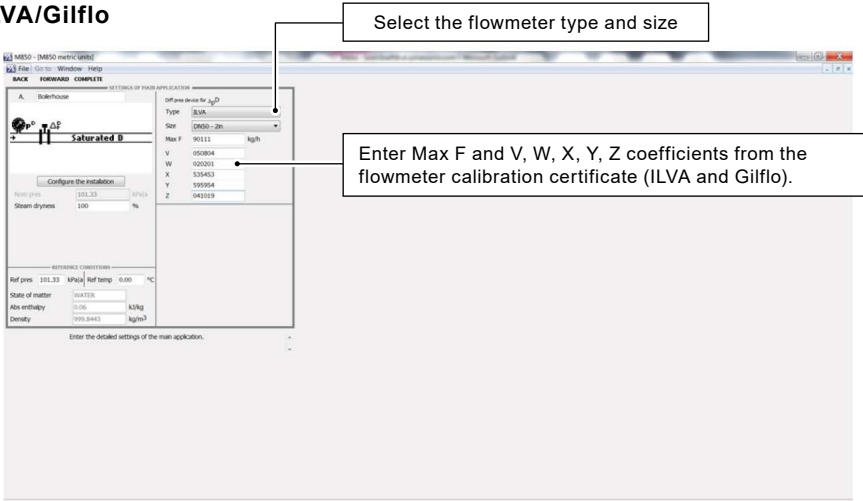

Orifice plate (M410)

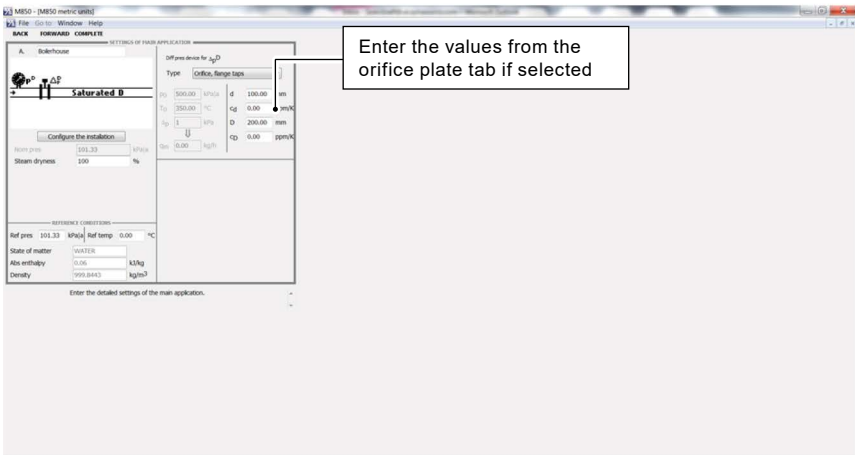

11. Forward through the next screen (pD computed value).
12. Forward through the next screen (qmD computed value).
13. Forward through the next screen (qvD computed value).
14. At next screen pD measured value (this is your pressure sensor) add a title i.e.: line pressure and assign an input between 2-6.
Change the units to bar g.
Set pressure range to suit sensor i.e. 4 mA = 0 bar g and 20 mA = 10 bar g.
15. Forward through the next screen (TcD computed value).

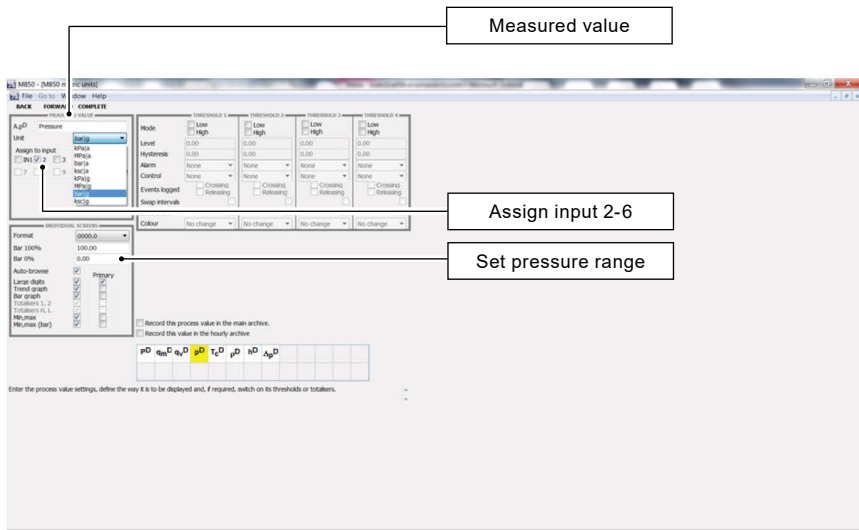

16. Forward through the next screen (pD computed value).
17. Forward through the next screen (hD computed value).
18. At next screen Pd measured value (this is your DP Cell), add a title i.e. 'Differential Pressure', select mbar units and assign to input 1.
19. Forward through the next screen (Assignment) - **Note:** The pressure range must be set.
20. Forward through the next screen (main archive).

21. At the next screen (main screen for Application A), 'Click' on the 'Mass flowrate' icon. The button will turn yellow.

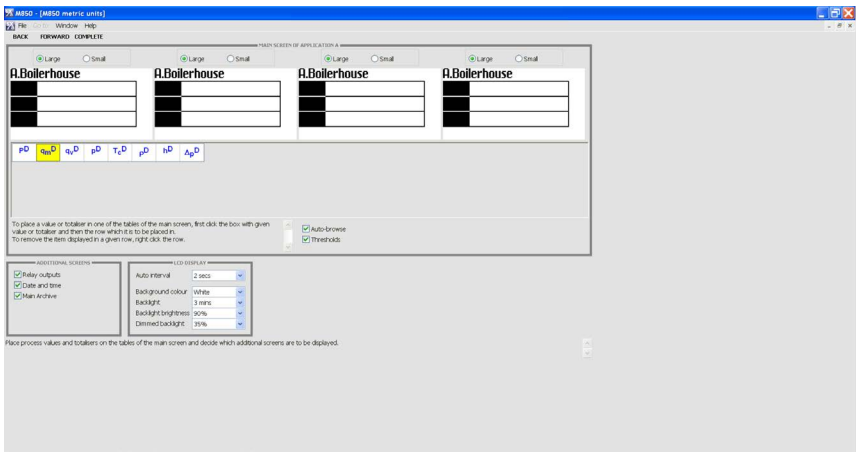

22. 'Click' on the top line of table A. The mass flowrate will show in the table.

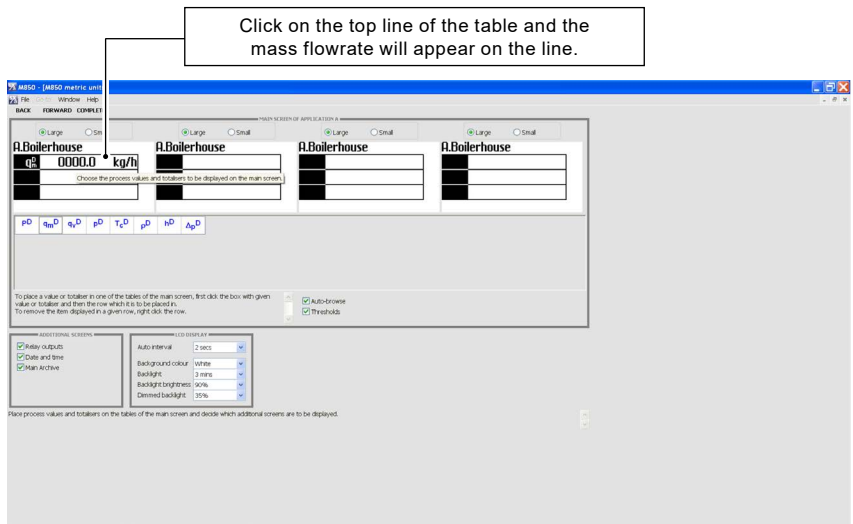

23. Repeat Step 22 for the pressure.

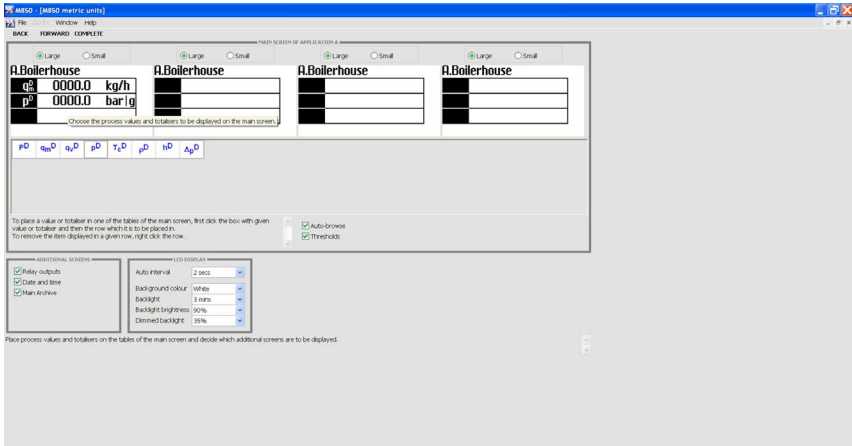

24. Forward through the next screen (4-20 mA outputs).

25. At next screen (media manager) 'Click' on 'Complete'.

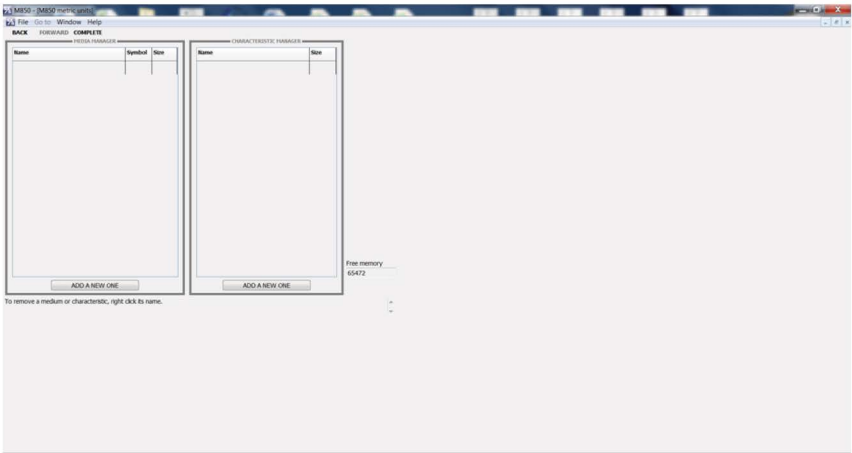

The configuration is now complete.

Save the file to your PC, and copy to a USB stick (memory stick), to enable you to download the file to the M850 flow computer.

Quickstart commissioning flowchart

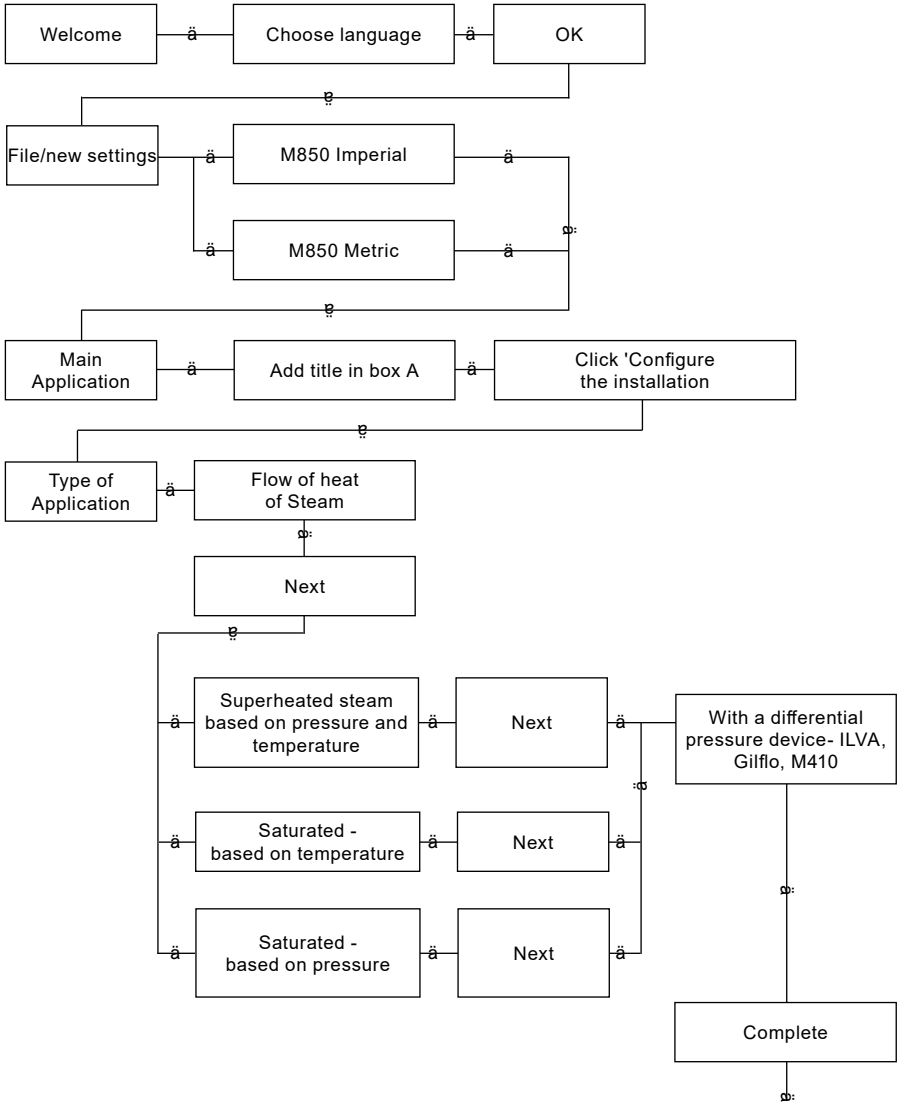

Continued on next page

Continued from previous page

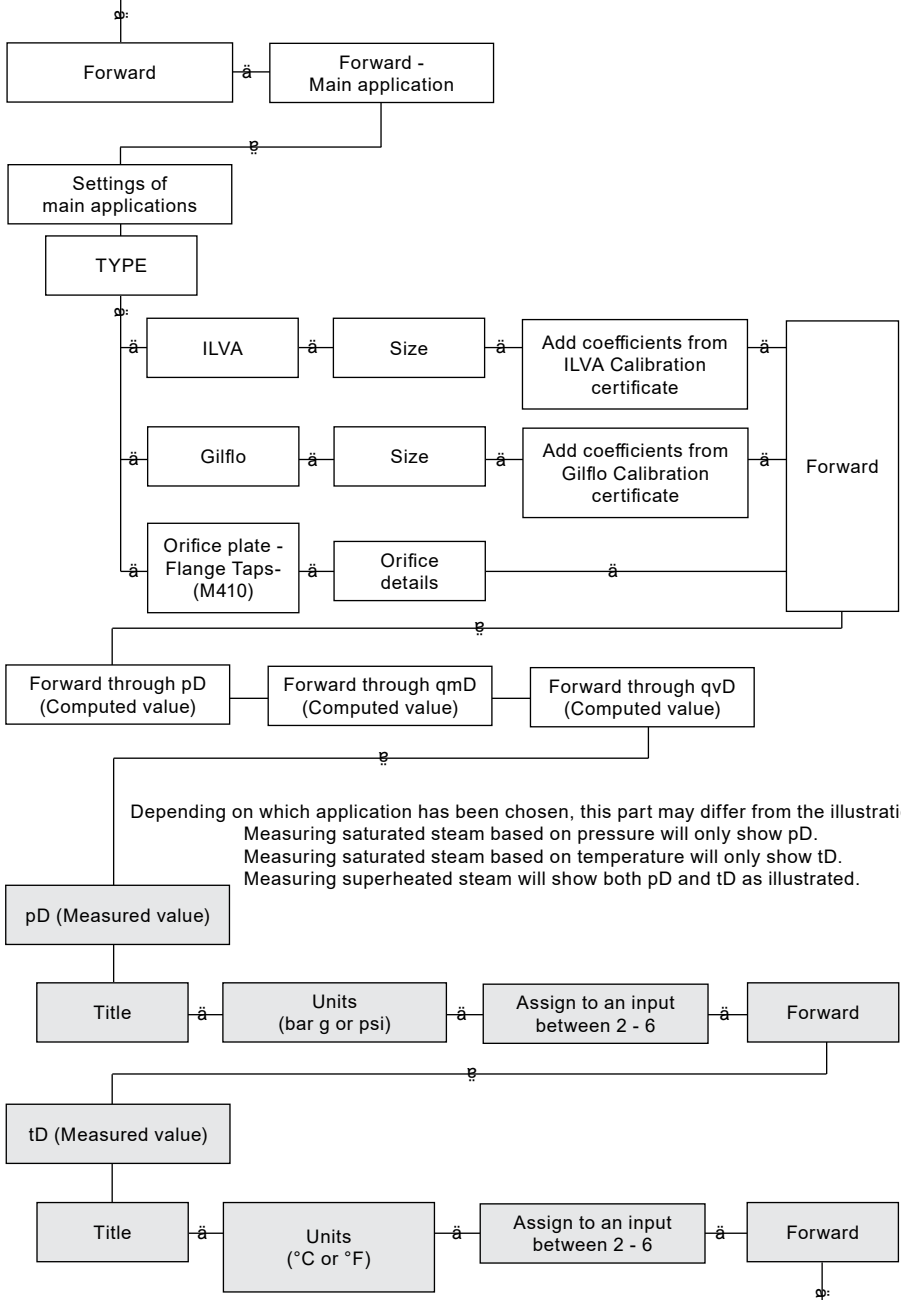

Continued on next page

Continued from previous page

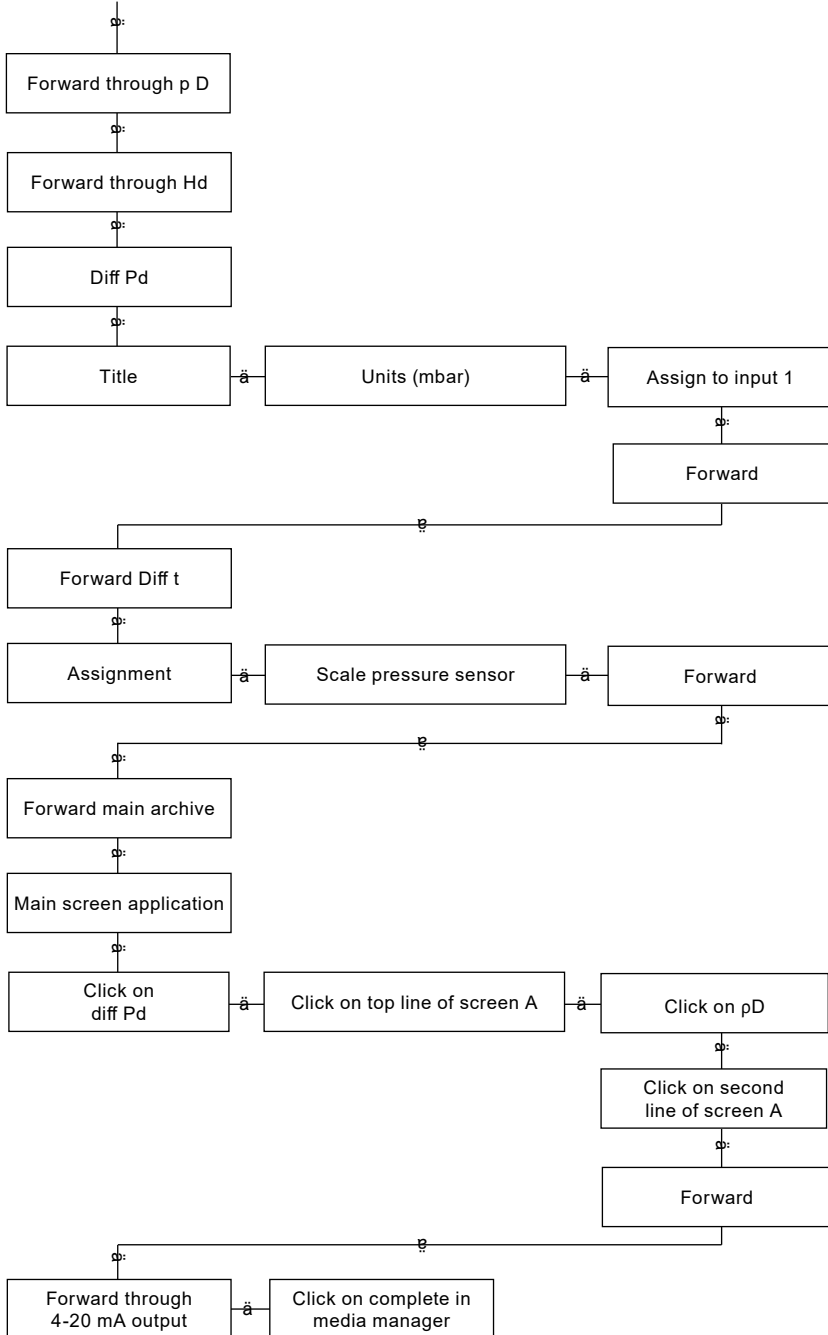

11. Functions only available to the administrator

11.1 Changing the Administrator Password

Changing the administrator password, see Section 5.7.1.

11.2 Administrator menu

The administrator decides which functions of the instrument should be password protected. Creates new users, give them names, and generates a password (number codes). 'ADMIN' also defines permissions for each user to perform password protected activities.

During the first configuration of the device, protected activity should be defined at first and then users accounts and permission assignment.

 → MAIN MENU → ADMINISTRATIVE DATA

ADMINISTRATIVE DATA
PROTECTED COMMANDS [1]

Archiving commands → No (Yes, No) [2]

Copy files → No (Yes, No) [3]

Resetting min, max → No (Yes, No) [4]

Adjusting clock → No (Yes, No) [5]

Resetting totalisers → No (Yes, No) [6]

Main settings → No (Yes, No) [7]

Threshold settings → No (Yes, No) [8]

Screen settings → No (Yes, No) [9]



Archiving settings → No (Yes, No) [10]

USERS AND ENTITLEMENTS [11]

LOG OUT AFTER → 5 mins (30 secs, 1, 2, 3, 5, 10 mins) [12]

MIN PASS LENGTH → 3digs. (3, 4, 5) [13]

Explanations:

- [1]: Actions are divided into groups. Each of them, may require entering a username and password. Thus, depending on the main application, it can be opt out completely of entering passwords (which always require additional operations on the keypad). It also allowed to select only specific operations that require passwords (e.g. changing the settings of the device), or to secure all possible actions (particularly when the recorded measurements are a document, and many people have access to the device). Selecting Yes means that the activities group will require a password.
- [2]: **Archiving commands** includes stopping (), and resuming () recording and setting up a new archive file, if this action does not erase another archive located in the internal memory.
- [3]: **Copying files** include copy/move/delete operations of any file stored in the internal memory.
- [4]: **Resetting min, max** relates to the function of resetting maximum, minimum and average values stored and viewed on screens.
- [5]: **Adjust clock** refers to the entitlements to change the time and date clock (date and time is recorded in the archive along with the results of measurements).
- [6]: **Resetting the totalisers.**
- [7]: **Main settings** includes the addition of user's characteristics and functions of changing instrument's settings except for setting alarm and control thresholds, setting displaying screens and the settings of archiving.
- [8]: **Thresholds settings** - setting of alarm and control thresholds.
- [9]: **Screen settings** refers to setting of displaying of the results – main screens, additional screens and detailed screens.
- [10]: **Archiving settings** – setting frequency, process values and operating mode.
- [11]: In the **Users and entitlements** menu, the administrator defines users and gives them entitlements (selecting group of functions that the user will be able to perform after entering a password). After creating a new user device generates the numeric password. The instrument does not allow to change the password to a very simple one (e.g. 11111). Each user has a separately defined entitlements. ADMIN can choose only those activities that had previously been declared as a password protected activities. In this menu, the administrator can also change a user's name and password or remove user.
- [12]: **Log out after** -- defines idle time after which the device automatically logs out. This function is to prevent accidentally leaving the device in logged mode, and to make changes by unAuthorised persons.
- [13]: **Minimum password length** prevents users from changing password on too short. The longer the password is, the stronger it is, but more digits must be enter when logging on.

11.3 New firmware



A brand new flow computer has all functions deactivated – it does not execute any measurements or calculations. As the first step user has to choose language and set the units, metric or imperial. Then the device may be configured. Used language may be changed later in settings menu. In order to change the units the device has to be reseted to the factory state.

The device firmware can be changed to a newer version or to the version with other features and possibilities. Substitution may be performed only by ADMIN user. This operation, if necessary, should be performed with extreme caution. The device can operate with a computer system or other devices and software change may affect it.

→ MAIN MENU → FIRMWARE AND LICENCES

FIRMWARE AND LICENCES

Load and install [1]

Licences granted [2]

Firmware version [3]

Serial number [4]

Explanations:

- [1]: Installing new firmware or license granting is done via USB flash memory. After inserting the USB into the slot on the front panel of the device in main menu select **Load and install**. The device automatically detects files with the new firmware and license. Selecting the button **INSTALL** starts the process which takes a few minutes. Some versions of the program may not be compatible with the existing version, and in that case the instrument does not allow for the installation. Programs with special functions may require purchase of additional licenses.
- [2]: A list of **licenses granted** to instrument. Some programs can be installed only in instruments with a specific license. Use of certain features may require additional licenses. (Prepared for future use, function not implemented in current firmware version.)
- [3]: **Firmware version** - information about the version of firmware installed in the instrument.
- [4]: The device in the internal non-volatile memory has inscribed its serial number. The same number is located on the nameplate of the device. This is the service information. The serial number is also stored in each archives, in order to identify the measurement data to the device.

11.4 Restoring factory settings

 → MAIN MENU → RESTORE FACTORY SETTINGS

MAIN MENU

Restore factory settings [1]

Explanation:

[1]: This function can change the settings entered by a user to the factory settings. It applies to all parameters grouped within the Settings menu, but does not change any other data stored in the device. The function should be used in special cases, for example, if user wants to set the device from the beginning, step by step.

11.5 Test of inputs and outputs

Function **Test inputs and outputs** is described in Section 12.

11.6 Functions available only for service

User with the SERVICE permissions (ADMIN after entering the service code) has an additionally access to the calibration of the device, and remove/move of Event logs and authorisation log. Both of these features can be found at the end of the main menu.



Unlike the other users, SERVICE user (ADMIN with a service code) does not log off automatically after a set period of inactivity. Administrator - SERVICE must remember to log out by himself.

12. Test functions

12.1 Test of inputs and outputs

Test inputs and outputs function are available only for the ADMIN user. It allows you to track the electrical signals of all enabled inputs, the status of all output relays and the current output. It also enable to force certain states on the outputs. Before starting the test, flow computer must be configured.

→ MAIN MENU → TEST INPUTS AND OUTPUTS



IN1	204.8 Ω	IN6	
IN2	284.6 Ω	IN7	
IN3	5.63 mA	IN8	5.75 mA
IN4	5.60 mA	IN9	Closed
IN5		IN10	0Hz
RL	O C O O	OUT1	3.60 mA
		OUT2	4.00 mA

Buttons: RL1...4, OUT1, OUT2

At the top of the screen are displayed the signals on the activated inputs. At the bottom left are showed output relays status (O = open, C = closed), and at the right current outputs 4-20 mA (---- means that the output is off). Black color of inscriptions indicates that the state is not a result of normal operation of the device, but was forced for the test. To enforce the desired states of the output relays press **RL1...4**.



IN1	204.8 Ω	IN6	
IN2	284.6 Ω	IN7	
IN3	5.63 mA	IN8	5.75 mA
IN4	5.60 mA	IN9	Closed
IN5		IN10	0Hz
RL	C C O O	OUT1	3.60 mA
		OUT2	4.00 mA

Buttons: WORK, ←, →

Using the horizontal arrows select an output, then force closing (pressing **C** button), opening (pressing **O** button) or normal work (pressing **WORK** button). The changes have an immediate effect.

To force the desire value of current output 4-20 mA press **OUT1** or **OUT2**.

Then insert the value using **+** and **-** buttons, and then press the **OK** button. To restore normal operating of 4-20 mA outputs press **OUT1** or **OUT2**.

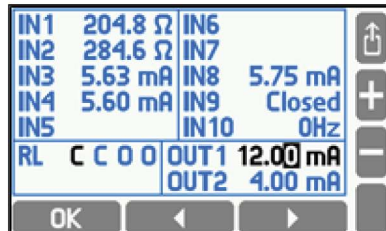

IN1	204.8 Ω	IN6	
IN2	284.6 Ω	IN7	
IN3	5.63 mA	IN8	5.75 mA
IN4	5.60 mA	IN9	Closed
IN5		IN10	0Hz
RL	C C O O	OUT1	12.00 mA
		OUT2	4.00 mA

Buttons: OK, ←, →, +, -

12.2 Port RS-485/RS-422

Function RS-485 monitor is a service function. After selecting, the ALARM LED blinks when data exchange on the RS-485 bus. To end a function, press the button **QUIT**.

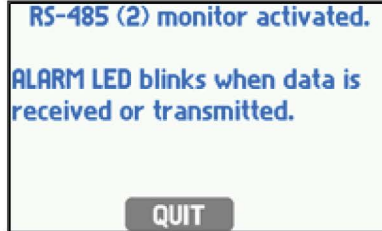

13. MODBUS protocol

Modbus RTU protocol allows for readout only of process values and totalisers. Readout uses 04 function – Read Input Register, registers with addresses starting with 3xxxx. To simplify notation in the further part only registers addresses in decimal notation are used and not their full name (3xxxx) corresponding to MODBUS protocol.

Using Modbus functions user can transfer data to computer system:

- results of measuring process,
- date and time from RTC (Real Time Clock can also be set).

There are two Modbus functions implemented:

- 04 – Read Input Registers,
- 10 – Write Multiple Registers.

Modbus RTU is available at RS-485 port and Modbus TCP is available at Ethernet port.

13.1 Serial transmission parameters and general information

- Operation mode: Modbus RTU
- Address: 001 (001, .. , 099)
- Speed: 9600 (1200, .. , 115, 2k)
- Parity EVEN (NONE, ODD, EVEN)
- Response delay (min): 50 ms (10, 20, 30, 50, 70, 100, 150, 200, 300, 400 ms).

Transmission parameters do not allow to set maximum time ('Response delay (max):') because in Modbus RTU mode response to a command is sent immediately. The maximum delay is not more than few ms. According to MODBUS standard in RTU mode a frame (transmitted information) is as follows:

Start	Address	Function	Data	CRC control	End
T1 ... T4	1 byte	1 byte	n bytes	2 bytes	T1 ... T4

Information transmitted from the master computer to the device is a query whereas the device sends a response.

13.2 Ethernet port settings for Modbus TCP

- IP (IP address assigned to M850),
- Port (typically 502),
- Mask (subnet mask, e.g. 255.255.255.0),
- Gate (e.g. 1.0.0.1),
- DHCP server (OFF for normal operation),
- Timeout (typically 60 s).

Note: Using port 502 is recommended, since it is registered for Modbus TCP. According to MODBUS standard in TCP/IP mode, the frame is as follows:

MBAP Header	Function	Data
7 bytes	1 byte	n bytes

Information transmitted from the master computer to the device is a query whereas the device sends a response.

13.3 Readout of current results and totalisers

The M850 device accepts 04 command – process values readout function (current process values and totalisers).

Readout function (query) has a form:

Function (1B)	Initial address (2B)	Number of registers (2B)
---------------	----------------------	--------------------------

Function – 04 HEX – process values and totalisers readout (input registers).

Initial address – an address of a device from which data are to be sent.

Number of registers – two-byte registers for readout.

In response the device transmits a sequence of characters in form of:

Function (1B)	Number of bytes (1B)	Data sequence (nB)
---------------	----------------------	--------------------

Function – acknowledge, in case of error 80 HEX value is added on to the command code.

Number of bytes – n bytes transmitted in response (but not number of registers).

Data sequence – n bytes of register contents.

13.4 Process values (main and auxiliary values) – Register addresses

Process values are available in floating point format.
The following table contains register addresses for main values.

Designation of system types:

W	The flow and heat of a liquid.
W-W (closed)	The flow and delta heat of a liquid in a closed supply-return installation.
W-W (different)	The flows and delta heat of a liquid in an installation with separate supply and return flowrates.
S	The flow and heat of steam.
SS-W (up to cond.)	The flow and delta heat in a closed superheated steam-condensate installation (steam condensation without further condensate cooling).
ST.S(p)-W (up to cond.)	The flows and delta heat in a closed saturated steam-condensate installation (steam condensation without further condensate cooling, pressure measurement).
ST.S(T)-W (up to cond.)	The flows and delta heat in a closed saturated steam-condensate installation (steam condensation without further condensate cooling, temperature measurement).
SS-W (closed)	The flow and delta heat in a closed superheated steam-condensate installation.
ST.S(p)-W (closed)	The flows and delta heat in a closed saturated steam-condensate installation (pressure measurement).
ST.S(T)-W (closed)	The flows and delta heat in a closed saturated steam-condensate installation (temperature measurement).
SS-W (different)	The flows and delta heat in a superheated steam-condensate installation with separate steam and condensate flowrates.
ST.S(p)-W (different)	The flows and delta heat in a saturated steam-condensate installation with separate steam and condensate flowrates (pressure measurement).
ST.S(T)-W (different)	The flows and delta heat in a saturated steam-condensate installation with separate steam and condensate flowrates (temperature measurement).
S production	The flow and delta heat in a steam-generating installation with the supplied water flowrate measured.
G	The flow of a gas.

Explanations:

1. In brackets there are given values which appear only in some configurations.
2. If water and steam pressures are equal the common pressure is marked with symbol p (or p_c). If only steam pressure is measured and water pressure is constant, then steam pressure is marked with symbol p^D (or p_c^D).
3. Upper index; D- means steam, W- water, S- supply, R - return (upper and lower indices are displayed one below another).

Designation of main and auxiliary values:

P	Heat flowrate.
qv/q_m	Volumetric/mass flowrate.
$p/p_c/\Delta p$	Pressure/pressure in saturation conditions/delta pressure (in differential pressure measurement).
$T/T_c/\Delta T$	Temperature/temperature in saturation conditions/temperature difference.
ρ	Specific density.
h	Enthalpy.
k	Thermal coefficient of water.

Register addresses for main values

Type of installation									
W	W-W (closed)	W-W (different)	S	SS-W (up to cond.)	ST.S(p)-W (up to cond.)	ST.S(T)-W (up to cond.)	SS-W (closed)	ST.S(p)-W (closed)	ST.S(T)-W (closed)
Main values									
	P	P		P	P	P	P	P	P
P^W			P^D	P^D	P^D	P^D	P^D	P^D	P^D
q_m^W	q_m	q_m^S	q_m^D	q_m	q_m	q_m	q_m	q_m	q_m
q_v^W	q_v^S	q_v^S	q_v^D	q_v^D	q_v^D	q_v^D	q_v^D	q_v^D	q_v^D
(p^W)	(p)	(p)	p^D	p	p	pc	$p^{(D)}$	$p^{(D)}$	pc $^{(D)}$
T^W	TS	TS	T^D	T^D	Tc	T	T^D	Tc^D	T^D
ρ^W	ρ^S	ρ^S	ρ^D	ρ^D	ρ^D	ρ^D	ρ^D	ρ^D	ρ^D
h^W	hS	hS	h^D	h^D	h^D	h^D	h^D	h^D	h^D
(Δp^W)	(Δp^S)	(Δp^S)	(Δp^D)	(Δp^D)	(Δp^D)	(Δp^D)	(Δp^D)	(Δp^D)	(Δp^D)
				P^W	P^W	P^W	P^W	P^W	P^W
		q_m^R							
	q_v^R	q_v^R		q_v^W	q_v^W	q_v^W	q_v^W	q_v^W	q_v^W
	T^R	T^R		T^R -cP			T^W	T^W	T^W
	ρ^R	ρ^R		ρ^W	ρ^W	ρ^W	ρ^W	ρ^W	ρ^W
	h^R	h^R		h^W	h^W	h^W	h^W	h^W	h^W
	(Δp^R)	(Δp^R)		(Δp^W)	(Δp^W)	(Δp^W)	(Δp^W)	(Δp^W)	(Δp^W)
	ΔT	ΔT							
	(kS, k ^R)								

The following table contains register addresses for auxiliary values. Auxiliary values are in sequence as they were entered during set up of the device.

Auxiliary values	Register addresses (in decimal format)					
	Application A	Application B	Application C	Application X	Application Y	Application Z
1	36, 37	88, 89	140, 141	156, 157	172, 173	188, 189
2	38, 39	90, 91	142, 143	158, 159	174, 175	190, 191
3	40, 41	92, 93	144, 145	160, 161	176, 177	192, 193
4	42, 43	94, 95	146, 147	162, 163	178, 179	194, 195
5	44, 45	96, 97	148, 149	164, 165	180, 181	196, 197
6	46, 47	98, 99	150, 151	166, 167	182, 183	198, 199
7	48, 49	100, 101	152, 153	168, 169	184, 185	200, 201
8	50, 51	102, 103	154, 155	170, 171	186, 187	202, 203

					Register addresses (in decimal format)		
SS-W (different)	ST.S(p)-W (different)	ST.S(T)-W (different)	S production	G			
					Application A	Application B	Application C
P	P	P	P		0, 1	52, 53	104, 105
P ^D	P ^D	P ^D	P ^D	qG	2, 3	54, 55	106, 107
q _m ^D	q _m ^D	q _m ^D	q _m	q _m G	4, 5	56, 57	108, 109
q _v ^D	q _v ^D	q _v ^D	q _v ^D	q _v G	6, 7	58, 59	110, 111
p ^(D)	p ^(D)	pc ^(D)	p ^(D)	(pG)	8, 9	60, 61	112, 113
T ^D	Tc ^D	T ^D	T ^D	(TG)	10, 11	62, 63	114, 115
ρ ^D	ρ ^D	ρ ^D	ρ ^D	ρG	12, 13	64, 65	116, 117
h ^D	h ^D	h ^D	h ^D		14, 15	66, 67	118, 119
(Δp ^D)	(Δp ^D)	(Δp ^D)	(Δp ^D)	(ΔpG)	16, 17	68, 69	120, 121
P ^W	P ^W	P ^W	P ^W		18, 19	70, 71	122, 123
q _m ^W	q _m ^W	q _m ^W			20, 21	72, 73	124, 125
q _v ^W	q _v ^W	q _v ^W	q _v ^W		22, 23	74, 75	126, 127
T ^W	T ^W	T ^W	T ^W		24, 25	76, 77	128, 129
ρ ^W	ρ ^W	ρ ^W	ρ ^W		26, 27	78, 79	130, 131
h ^W	h ^W	h ^W	h ^W		28, 29	80, 81	132, 133
(Δp ^W)	(Δp ^W)	(Δp ^W)			30, 31	82, 83	134, 135
					32, 33	84, 85	136, 137
					34, 35	86, 87	138, 139

13.4.1 Process value format

All process values (main values and auxiliary values) are in floating point format requiring two Modbus RTU registers (4 bytes) according to IEEE-754 standard for 32-bit numbers.

IEEE-754 standard for 32-bit floating point single number of single precision :

Register	30002 (address 0001)				30001 (address 0000)	
Byte	4		3		2	1
Bit	31	30..24	23	22..16	15..08	07..00
IEEE-754	S	E (8b)	M (23b, only fraction part)			

Where:

- M (mantissa): is a normalised value within the interval [1;2)- right side open interval. Only fraction part of mantissa is noted (e.g. for binary number 1,1011101 mantissa equals to 1011101, more precisely in notation on 23 bits:10111010000000000000000).
- E (exponent): exponent value is shifted by 127 (bias).
- S (sign): 0 – positive number, 1 – negative number.

The number value can be calculated from the formula:

$$x = (-1)^S * M * 2^{(E-bias)} ; \text{ where bias: } 127$$

For example a sequence of response characters (HEX):

01 04 04 9E E4 43 1C A4 A2 (read from the device)

- Acknowledgment of an address (01) and function (04), number of bytes (04).
- Value 9E E4 43 1C, in sequence register 0000 and 0001.
- CRC (A4 A2).

Presenting the value in appropriate sequence (0001 and 0000): 43 1C 9E E4

and in binary form:

01000011 00011100 10011110 11100100

one can read

- Mantissa: 1,0011100 10011110 11100100 (in decimal notation: approx. 1,22265625)
- Exponent: 10000110 – 01111111 = 00000111 (in decimal notation: 7)
- Sign: 0

what gives a decimal result: $(-1)^0 * 1.22265625 * 2^7 = 156.5$

13.5 Totalisers

For each flowrate or heat flowrate value up to 4 totalisers may be active:

- Main totaliser ($\Sigma 1$).
- Auxiliary totaliser ($\Sigma 2$).
- Overrange totaliser (ΣH).
- Underrange totaliser (ΣL).

Totalisers are available in two formats: floating point and integer number.

Note: Totalisers values in Modbus RTU registers are updated every 5 sec.

13.5.1 Register addresses for totalisers in floating point format

Each totaliser value is 4 registers long (8 bytes).

The following table contains register addresses for totalisers of the main values.

Note: Symbols established in following table corresponds with the table in Section 13.4.

Register addresses for totalisers of the main values (in 64-bit floating point double format).

Type of installation									
W	W-W (closed)	W-W (different)	S	SS-W (up to cond.)	ST.S(p)-W (up to cond.)	ST.S(T)-W (up to cond.)	SS-W (closed)	ST.S(p)-W (closed)	ST.S(T)-W (closed)
Main values									
	P	P		P	P	P	P	P	P
P^W			P^D	P^D	P^D	P^D	P^D	P^D	P^D
q_m^W	q_m	q_m^S	q_m^D	q_m	q_m	q_m	q_m	q_m	q_m
q_v^W	q_v^S	q_v^S	q_v^D	q_v^D	q_v^D	q_v^D	q_v^D	q_v^D	q_v^D
				P^W	P^W	P^W	P^W	P^W	P^W
		q_m^R							
	q_v^R	q_v^R		q_v^W	q_v^W	q_v^W	q_v^W	q_v^W	q_v^W

SS-W (different)	ST.S(p)-W (different)	ST.S(T)-W (different)	S production	G	Totaliser type	Register addresses (in decimal format)		
						Application A	ApplicationB	Application C
P	P	P	P		1	256...259	496...499	736...739
					2	260...263	500...503	740...743
					H	264...267	504...507	744...747
					L	268...271	508...511	748...751
P ^D	P ^D	P ^D	P ^D	q ^G	1	272...275	512...515	752...755
					2	276...279	516...519	756...759
					H	280...283	520...523	760...763
					L	284...287	524...527	764...767
q _m ^D	q _m ^D	q _m ^D	q _m	q _m ^G	1	288...291	528...531	768...771
					2	292...295	532...535	772...775
					H	296...299	536...539	776...779
					L	300...303	540...543	780...783
q _v ^D	q _v ^D	q _v ^D	q _v ^D	q _v ^G	1	304...307	544...547	784...787
					2	308...311	548...551	788...791
					H	312...315	552...555	792...795
					L	316...319	556...559	796...799
P ^W	P ^W	P ^W	P ^W		1	320...323	560...563	800...803
					2	324...327	564...567	804...807
					H	328...331	568...571	808...811
					L	332...335	572...575	812...815
q _m ^W	q _m ^W	q _m ^W			1	336...339	576...579	816...819
					2	340...343	580...583	820...823
					H	344...347	584...587	824...827
					L	348...351	588...591	828...831
q _v ^W	q _v ^W	q _v ^W	q _v ^W		1	352...355	592...595	832...835
					2	356...359	596...599	836...839
					H	360...363	600...603	840...843
					L	364...367	604...607	844...847

M850-W and M850-P Flow Computers

The following table contains register addresses for totalisers of the auxiliary values. Auxiliary values, as well as their totalisers are in sequence as they were entered during set up of the device.

**Register addresses for totalisers of auxiliary values
(in 64-bit floating point double format).**

Auxiliary values	Totaliser type	Register addresses (in decimal format)					
		Application A	Application B	Application C	Application X	Application Y	Application Z
1	1	368...371	608...611	848...851	976...979	1104...1107	1232...1235
	2	372...375	612...615	852...855	980...983	1108...1111	1236...1239
	H	376...379	616...619	856...859	984...987	1112...1115	1240...1243
	L	380...383	620...623	860...863	988...991	1116...1119	1244...1247
2	1	384...387	624...627	864...867	992...995	1120...1123	1248...1251
	2	388...391	628...631	868...871	996...999	1124...1127	1252...1255
	H	392...395	632...635	872...875	1000...1003	1128...1131	1256...1259
	L	396...399	636...639	876...879	1004...1007	1132...1135	1260...1263
3	1	400...403	640...643	880...883	1008...1011	1136...1139	1264...1267
	2	404...407	644...647	884...887	1012...1015	1140...1143	1268...1271
	H	408...411	648...651	888...891	1016...1019	1144...1147	1272...1275
	L	412...415	652...655	892...895	1020...1023	1148...1151	1276...1279
4	1	416...419	656...659	896...899	1024...1027	1152...1155	1280...1283
	2	420...423	660...663	900...903	1028...1031	1156...1159	1284...1287
	H	424...427	664...667	904...907	1032...1035	1160...1163	1288...1291
	L	428...431	668...671	908...911	1036...1039	1164...1167	1292...1295
5	1	432...435	672...675	912...915	1040...1043	1168...1171	1296...1299
	2	436...439	676...679	916...919	1044...1047	1172...1175	1300...1303
	H	440...443	680...683	920...923	1048...1051	1176...1179	1304...1307
	L	444...447	684...687	924...927	1052...1055	1180...1183	1308...1311
6	1	448...451	688...691	928...931	1056...1059	1184...1187	1312...1315
	2	452...455	692...695	932...935	1060...1063	1188...1191	1316...1319
	H	456...459	696...699	936...939	1064...1067	1192...1195	1320...1323
	L	460...463	700...703	940...943	1068...1071	1196...1199	1324...1327
7	1	464...467	704...707	944...947	1072...1075	1200...1203	1328...1331
	2	468...471	708...711	948...951	1076...1079	1204...1207	1332...1335
	H	472...475	712...715	952...955	1080...1083	1208...1211	1336...1339
	L	476...479	716...719	956...959	1084...1087	1212...1215	1340...1343
8	1	480...483	720...723	960...963	1088...1091	1216...1219	1344...1347
	2	484...487	724...727	964...967	1092...1095	1220...1223	1348...1351
	H	488...491	728...731	968...971	1096...1099	1224...1227	1352...1355
	L	492...495	732...735	972...975	1100...1103	1228...1231	1356...1359

13.5.2 Floating point format for totalisers

According to IEEE-754 standard for 64-bit floating point double (8 byte value or 4 register in Modbus RTU):

Register	30214 (address 0213)				30213		30212		30211	
Byte	8		7		6	5	4	3	2	1
Bit	63	62..56	55..52	51..48	47..40	39..32	31..24	23..16	15..8	7..0
IEEE	S	E (11b)	M (52b, fraction part only)							

Where:

- M (mantissa): is a normalised value within the interval [1;2)- right side open interval. Only fraction part of mantissa is noted.
- E (exponent): exponent value is biased by 1023 (bias).
- S (character): 0 – positive number, 1 – negative number.

The number value can be calculated from the formula:

$$x = (-1)^S * M * 2^{(E-bias)}$$

Where bias: 1023

13.5.3 Register addresses for totalisers in integer format

The totaliser values are also available in double integer (4 byte) format. Only not rounded integer part of the totaliser value is available in this format in range from -999 999 999 to 999 999 999. Each totaliser value is 2 registers long (4 bytes).

The following table contains register addresses for totalisers of the main values.

Note! Symbols established in following table corresponds with the table in Section 13.4.

Register addresses for totalisers of the main values (in integer format).

Type of installation									
W	W-W (closed)	W-W (different)	S	SS-W (up to cond.)	ST.S(p)-W (up to cond.)	ST.S(T)-W (up to cond.)	SS-W (closed)	ST.S(p)-W (closed)	ST.S(T)-W (closed)
Main values									
	P	P		P	P	P	P	P	P
P^W			P^D	P^D	P^D	P^D	P^D	P^D	P^D
q_m^W	q_m	q_m^S	q_m^D	q_m	q_m	q_m	q_m	q_m	q_m
q_v^W	q_v^S	q_v^S	q_v^D	q_v^D	q_v^D	q_v^D	q_v^D	q_v^D	q_v^D
				P^W	P^W	P^W	P^W	P^W	P^W
		q_m^R							
	q_v^R	q_v^R		q_v^W	q_v^W	q_v^W	q_v^W	q_v^W	q_v^W

SS-W (different)	ST.S(p)-W (different)	ST.S(T)-W (different)	S production	G	Totaliser type	Register addresses (in decimal format)		
						Application A	Application B	Application C
P	P	P	P		1	1408, 1409	1528, 1529	1648, 1649
					2	1410, 1411	1530, 1531	1650, 1651
					H	1412, 1413	1532, 1533	1652, 1653
					L	1414, 1415	1534, 1535	1654, 1655
P ^D	P ^D	P ^D	P ^D	q ^E	1	1416, 1417	1536, 1537	1656, 1657
					2	1418, 1419	1538, 1539	1658, 1659
					H	1420, 1421	1540, 1541	1660, 1661
					L	1422, 1423	1542, 1543	1662, 1663
q _m ^D	q _m ^D	q _m ^D	q _m	q _m ^G	1	1424, 1425	1544, 1545	1664, 1665
					2	1426, 1427	1546, 1547	1666, 1667
					H	1428, 1429	1548, 1549	1668, 1669
					L	1430, 1431	1550, 1551	1670, 1671
q _v ^D	q _v ^D	q _v ^D	q _v ^D	q _v ^G	1	1432, 1433	1552, 1553	1672, 1673
					2	1434, 1435	1554, 1555	1674, 1675
					H	1436, 1437	1556, 1557	1676, 1677
					L	1438, 1439	1558, 1559	1678, 1679
P ^W	P ^W	P ^W	P ^W		1	1440, 1441	1560, 1561	1680, 1681
					2	1442, 1443	1562, 1563	1682, 1683
					H	1444, 1445	1564, 1565	1684, 1685
					L	1446, 1447	1566, 1567	1686, 1687
q _m ^W	q _m ^W	q _m ^W			1	1448, 1449	1568, 1569	1688, 1689
					2	1450, 1451	1570, 1571	1690, 1691
					H	1452, 1453	1572, 1573	1692, 1693
					L	1454, 1455	1574, 1575	1694, 1695
q _v ^W	q _v ^W	q _v ^W	q _v ^W		1	1456, 1457	1576, 1577	1696, 1697
					2	1458, 1459	1578, 1579	1698, 1699
					H	1460, 1461	1580, 1581	1700, 1701
					L	1462, 1463	1582, 1583	1702, 1703

M850-W and M850-P Flow Computers

The following table contains register addresses for totalisers of the auxiliary values. Auxiliary values, as well as their totalisers are in sequence as they were entered during set up of the device.

Register addresses for totalisers of the auxiliary values (in integer format)

Auxiliary values	Totaliser type	Register addresses (in decimal format)					
		Application A	Application B	Application C	Application X	Application Y	Application Z
1	1	1464, 1465	1584, 1585	1704, 1705	1768, 1769	1832, 1833	1896, 1897
	2	1466, 1467	1586, 1587	1706, 1707	1770, 1771	1834, 1835	1898, 1899
	H	1468, 1469	1588, 1589	1708, 1709	1772, 1773	1836, 1837	1900, 1901
	L	1470, 1471	1590, 1591	1710, 1711	1774, 1775	1838, 1839	1902, 1903
2	1	1472, 1473	1592, 1593	1712, 1713	1776, 1777	1840, 1841	1904, 1905
	2	1474, 1475	1594, 1595	1714, 1715	1778, 1779	1842, 1843	1906, 1907
	H	1476, 1477	1596, 1597	1716, 1717	1780, 1781	1844, 1845	1908, 1909
	L	1478, 1479	1598, 1599	1718, 1719	1782, 1783	1846, 1847	1910, 1911
3	1	1480, 1481	1600, 1601	1720, 1721	1784, 1785	1848, 1849	1912, 1913
	2	1482, 1483	1602, 1603	1722, 1723	1786, 1787	1850, 1851	1914, 1915
	H	1484, 1485	1604, 1605	1724, 1725	1788, 1789	1852, 1853	1916, 1917
	L	1486, 1487	1606, 1607	1726, 1727	1790, 1791	1854, 1855	1918, 1919
4	1	1488, 1489	1608, 1609	1728, 1729	1792, 1793	1856, 1857	1920, 1921
	2	1490, 1491	1610, 1611	1730, 1731	1794, 1795	1858, 1859	1922, 1923
	H	1492, 1493	1612, 1613	1732, 1733	1796, 1797	1860, 1861	1924, 1925
	L	1494, 1495	1614, 1615	1734, 1735	1798, 1799	1862, 1863	1926, 1927
5	1	1496, 1497	1616, 1617	1736, 1737	1800, 1801	1864, 1865	1928, 1929
	2	1498, 1499	1618, 1619	1738, 1739	1802, 1803	1866, 1867	1930, 1931
	H	1500, 1501	1620, 1621	1740, 1741	1804, 1805	1868, 1869	1932, 1933
	L	1502, 1503	1622, 1623	1742, 1743	1806, 1807	1870, 1871	1934, 1935
6	1	1504, 1505	1624, 1625	1744, 1745	1808, 1809	1872, 1873	1936, 1937
	2	1506, 1507	1626, 1627	1746, 1747	1810, 1811	1874, 1875	1938, 1939
	H	1508, 1509	1628, 1629	1748, 1749	1812, 1813	1876, 1877	1940, 1941
	L	1510, 1511	1630, 1631	1750, 1751	1814, 1815	1878, 1879	1942, 1943
7	1	1512, 1513	1632, 1633	1752, 1753	1816, 1817	1880, 1881	1944, 1945
	2	1514, 1515	1634, 1635	1754, 1755	1818, 1819	1882, 1883	1946, 1947
	H	1516, 1517	1636, 1637	1756, 1757	1820, 1821	1884, 1885	1948, 1949
	L	1518, 1519	1638, 1639	1758, 1759	1822, 1823	1886, 1887	1950, 1951
8	1	1520, 1521	1640, 1641	1760, 1761	1824, 1825	1888, 1889	1952, 1953
	2	1522, 1523	1642, 1643	1762, 1763	1826, 1827	1890, 1891	1954, 1955
	H	1524, 1525	1644, 1645	1764, 1765	1828, 1829	1892, 1893	1956, 1957
	L	1526, 1527	1646, 1647	1766, 1767	1830, 1831	1894, 1895	1958, 1959

13.6 Clock read out and setting

Current time is read using 04 command.

Registers' addresses of clock

Registers' addresses (in DEC format)	Format	Description	
		High byte	Low byte
1020	Time	Year	Month
1021	Time	Day	Hour
1022	Time	Minute	Second

Note:

For instance, for 2 byte number AB:

B – low 8 bits (low byte),

A – high 8 bits (high byte).

Year, month, Day, hour, minute, second should be entered in HEX format. In the following table is an example for date 2009-12-25 and time 15:40:00:

Registers' addresses (dec)	Number
1020	090C
1021	190F
1022	2800

To adjust clock's settings user should use 10 command. This command have to contain strictly all three registers. In another time will be rejected with error code 02.

13.7 Error code

If an error message is sent as a response, a value of 80 (hex) is added onto the command code value.

Error codes possible for the device are:

- 01 HEX – incorrect function (in case of diagnostics also impermissible subfunction).
- 02 HEX – incorrect initial address.
- 03 HEX – incorrect number of points.

Queries are not confirmed by a response in case of:

- Parity error.
- CRC errors.
- Address error.

14. BACnet communications

BACnet functionality in the M850

BACnet (Building Automation and Control Network) is the open data communications protocol which has been developed by ASHRAE.

14.1 BACnet Objects

BACnet defines a standard set of Objects, each of which has a standard set of Properties. Properties describe the Object, present values, units, description, device type etc.

14.2 BACnet Services

Services are commands sent to another device to perform some actions. Most often it is the reading of Object properties or device status.

14.3 List of supported services in the M850

BACnet service	BACnet MSTP		BACnet IP	
	Initiate	Execute	Initiate	Execute
ReadProperty		x		X
ReadPropertyMultilpe		x		x
WriteProperty*		x		X
TimeSynchronization		x		X
Who-Is				X
I-Am			X	
Who-Has				X
I-Have			X	

* The service is supported, but the M850 does not have any values to write.

14.4 List of supported BACnet Objects in the M850

Bacnet Object	BACnet MSTP	BACnet IP
Device	x	x
AnalogInput	x	x
AnalogValue	x	x
LargeAnalogValue	x	x

14.5 Addressing BACnet Objects in the M850

The number of objects that are available in the BACnet network depends on the configuration of the M850. All measurement values read from physical inputs are AnalogInput object. The computed by M850 (e.g. Enthalpy) are AnalogValue object. Totalizers are assigned to LargeAnalogValue object.

The tables in the following Sections show the value of object instances, depending on the selected measurement systems.

14.6 Instance numbers for main values

Type of installation									
W	W-W (closed)	W-W (different)	S	SS-W (up to cond.)	ST.S(p)-W (up to cond.)	ST.S(T)-W (up to cond.)	SS-W (closed)	ST.S(p)-W (closed)	ST.S(T)-W (closed)
Main values									
	P	P		P	P	P	P	P	P
p^W			p^D	p^D	p^D	p^D	p^D	p^D	p^D
q_m^W	q_m	q_m^S	q_m^D	q_m	q_m	q_m	q_m	q_m	q_m
q_v^W	q_v^S	q_v^S	q_v^D	q_v^D	q_v^D	q_v^D	q_v^D	q_v^D	q_v^D
(p^W)	(p)	(p)	p^D	p	p	p_C	$p^{(D)}$	$p^{(D)}$	$p_C^{(D)}$
T^W	T^S	T^S	T^D	T^D	T_C	T	T^D	T_C^D	T^D
ρ^W	ρ^S	ρ^S	ρ^D	ρ^D	ρ^D	ρ^D	ρ^D	ρ^D	ρ^D
h^W	h^S	h^S	h^D	h^D	h^D	h^D	h^D	h^D	h^D
(Δp^W)	(Δp^S)	(Δp^S)	(Δp^D)	(Δp^D)	(Δp^D)	(Δp^D)	(Δp^D)	(Δp^D)	(Δp^D)
				p^W	p^W	p^W	p^W	p^W	p^W
		q_m^R							
	q_v^R	q_v^R		q_v^W	q_v^W	q_v^W	q_v^W	q_v^W	q_v^W
	T^R	T^R		T_C^P			T^W	T^W	T^W
	ρ^R	ρ^R		ρ^W	ρ^W	ρ^W	ρ^W	ρ^W	ρ^W
	h^R	h^R		h^W	h^W	h^W	h^W	h^W	h^W
	(Δp^R)	(Δp^R)		(Δp^W)	(Δp^W)	(Δp^W)	(Δp^W)	(Δp^W)	(Δp^W)
	ΔT	ΔT							
	(k^S, k^R)								

					Register addresses (in decimal format)		
SS-W (different)	ST.S(p)-W (different)	ST.S(T)-W (different)	S production	G			
P	P	P	P		0	52	104
p^D	p^D	p^D	p^D	q^G	2	54	106
q_m^D	q_m^D	q_m^D	q_m	q_m^G	4	56	108
q_v^D	q_v^D	q_v^D	q_v^D	q_v^G	6	58	110
$p^{(D)}$	$p^{(D)}$	$p_c^{(D)}$	$p^{(D)}$	(p^G)	8	60	112
T^D	T_c^D	T^D	T^D	(T^G)	10	62	114
ρ^D	ρ^D	ρ^D	ρ^D	ρ^G	12	64	116
h^D	h^D	h^D	h^D		14	66	118
(Δp^D)	(Δp^D)	(Δp^D)	(Δp^D)	(Δp^G)	16	68	120
p^W	p^W	p^W	p^W		18	70	122
q_m^W	q_m^W	q_m^W			20	72	124
q_v^W	q_v^W	q_v^W	q_v^W		22	74	126
T^W	T^W	T^W	T^W		24	76	128
ρ^W	ρ^W	ρ^W	ρ^W		26	78	130
h^W	h^W	h^W	h^W		28	80	132
(Δp^W)	(Δp^W)	(Δp^W)			30	82	134
					32	84	136
					34	86	138

14.7 Instance numbers for totalizers of the main values

Type of installation									
W	W-W (closed)	W-W (different)	S	SS-W (up to cond.)	ST.S(p)-W (up to cond.)	ST.S(T)-W (up to cond.)	SS-W (closed)	ST.S(p)-W (closed)	ST.S(T)-W (closed)
Main values									
	P	P		P	P	P	P	P	P
P^W			P^D	P^D	P^D	P^D	P^D	P^D	P^D
q_m^W	q_m	q_m^S	q_m^D	q_m	q_m	q_m	q_m	q_m	q_m
q_v^W	q_v^S	q_v^S	q_v^D	q_v^D	q_v^D	q_v^D	q_v^D	q_v^D	q_v^D
				P^W	P^W	P^W	P^W	P^W	P^W
		q_m^R							
	q_v^R	q_v^R		q_v^W	q_v^W	q_v^W	q_v^W	q_v^W	q_v^W

					Totalizer type	Register addresses (in decimal format)		
SS-W (different)	ST.S(p)-W (different)	ST.S(T)-W (different)	S production	G		Application A	ApplicationB	Application C
P	P	P	P		1	256	496	736
					2	260	500	740
					H	264	504	744
					L	268	508	748
P ^D	P ^D	P ^D	P ^D	q ^G	1	272	512	752
					2	276	516	756
					H	280	520	760
					L	284	524	764
q _m ^D	q _m ^D	q _m ^D	q _m	q _m ^G	1	288	528	768
					2	292	532	772
					H	296	536	776
					L	300	540	780
q _v ^D	q _v ^D	q _v ^D	q _v ^D	q _v ^G	1	304	544	784
					2	308	548	788
					H	312	552	792
					L	316	556	796
P ^w	P ^w	P ^w	P ^w		1	320	560	800
					2	324	564	804
					H	328	568	808
					L	332	572	812
q _m ^w	q _m ^w	q _m ^w			1	336	576	816
					2	340	580	820
					H	344	584	824
					L	348	588	828
q _v ^w	q _v ^w	q _v ^w	q _v ^w		1	352	592	832
					2	356	596	836
					H	360	600	840
					L	364	604	844

M850-W and M850-P Flow Computers

14.8 Instance numbers of auxiliary values

Auxiliary values	Register addresses (in decimal format)					
	Application A	Application B	Application C	Application X	Application Y	Application Z
1	36	88	140	156	172	188
2	38	90	142	158	174	190
3	40	92	144	160	176	192
4	42	94	146	162	178	194
5	44	96	148	164	180	196
6	46	98	150	166	182	198
7	48	100	152	168	184	200
8	50	102	154	170	186	202

14.9 Instance numbers for totalizers of auxiliary values

Auxiliary values	Totalizer type	Register addresses (in decimal format)					
		Application A	Application B	Application C	Application X	Application Y	Application Z
1	1	368	608	848	976	1104	1232
	2	372	612	852	980	1108	1236
	H	376	616	856	984	1112	1240
	L	380	620	860	988	1116	1244
2	1	384	624	864	992	1120	1248
	2	388	628	868	996	1124	1252
	H	392	632	872	1000	1128	1256
	L	396	636	876	1004	1132	1260
3	1	400	640	880	1008	1136	1264
	2	404	644	884	1012	1140	1268
	H	408	648	888	1016	1144	1272
	L	412	652	892	1020	1148	1276
4	1	416	656	896	1024	1152	1280
	2	420	660	900	1028	1156	1284
	H	424	664	904	1032	1160	1288
	L	428	668	908	1036	1164	1292
5	1	432	672	912	1040	1168	1296
	2	436	676	916	1044	1172	1300
	H	440	680	920	1048	1176	1304
	L	444	684	924	1052	1180	1308
6	1	448	688	928	1056	1184	1312
	2	452	692	932	1060	1188	1316
	H	456	696	936	1064	1192	1320
	L	460	700	940	1068	1196	1324
7	1	464	704	944	1072	1200	1328
	2	468	708	948	1076	1204	1332
	H	472	712	952	1080	1208	1336
	L	476	716	956	1084	1212	1340
	1	480	720	960	1088	1216	1344
	2	484	724	964	1092	1220	1348
	H	488	728	968	1096	1224	1352
L	492	732	972	1100	1228	1356	

14.10 Setting BACnet MSTP communication in the M850

BACnet MSTP works on RS-485 port.

To set communication in BACnet MSTP:

1. Enter RS-485 port configuration menu
2. Change protocol to BACnet
3. Enter Device ID from 1 to 254
4. Select baud rate from 9600 to 115200 bps
5. Enter Dev instance from 1 to 4194303
6. Enable or disable Time Synchronization over BACnet network

14.11 Setting BACnet IP communication in the M850

BACnet IP works on Ethernet port.

To set communication in BACnet IP:

1. Enter Ethernet port configuration menu
2. Enter IP address
3. Enter port in from 47808 to 47823
4. Enter network Mask
5. Enter Dev instance from 1 to 4194303
6. Enable or disable Time Synchronization over BACnet network

