

M33F ISO, M33S ISO and M33V ISO Ball Valves

Installation and Maintenance Instructions

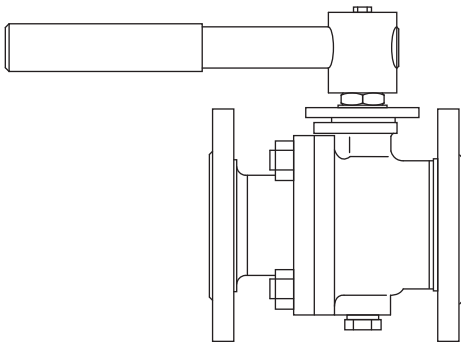

1. Safety information
2. General product information
3. Installation
4. Commissioning
5. Operation
6. Maintenance
7. Spare parts

1. Safety information

Safe operation of these products can only be guaranteed if they are properly installed, commissioned, used and maintained by qualified personnel (see Section 1.11) in compliance with the operating instructions. General installation and safety instructions for pipeline and plant construction, as well as the proper use of tools and safety equipment must also be complied with.

1.1 Intended use

Referring to the Installation and Maintenance Instructions, name-plate and Technical Information Sheet, check that the product is suitable for the intended use/application.

The products listed below comply with the requirements of the Pressure Equipment Directive (PED) and carry the  mark when so required. The products fall within the following Pressure Equipment Directive categories:

Product	Size	Group 1 Gases	Group 2 Gases	Group 1 Liquids	Group 2 Liquids
M33F ISO, M33S ISO and M33V ISO	DN50	2	1	2	SEP
	DN65	2	1	2	SEP
	DN80	2	1	2	SEP
	DN100	2	1	2	SEP
	DN150	2	2	2	SEP
	DN200	2	2	2	SEP

- i) The product has been specifically designed for use on steam, compressed air, water and other industrial fluids that are in Group 2 of the above mentioned Pressure Equipment Directive.
- ii) Check material suitability, pressure and temperature and their maximum and minimum values. If the maximum operating limits of the product are lower than those of the system in which it is being fitted, or if malfunction of the product could result in a dangerous overpressure or overtemperature occurrence, ensure a safety device is included in the system to prevent such over-limit situations.
- iii) Determine the correct installation situation and direction of fluid flow.
- iv) Spirax Sarco products are not intended to withstand external stresses that may be induced by any system to which they are fitted. It is the responsibility of the installer to consider these stresses and take adequate precautions to minimise them.
- v) Remove protection covers from all connections and protective film from all name-plates, where appropriate, before installation on steam or other high temperature applications.

1.2 Access

Ensure safe access and if necessary a safe working platform (suitably guarded) before attempting to work on the product. Arrange suitable lifting gear if required.

1.3 Lighting

Ensure adequate lighting, particularly where detailed or intricate work is required.

1.4 Hazardous liquids or gases in the pipeline

Consider what is in the pipeline or what may have been in the pipeline at some previous time. Consider: flammable materials, substances hazardous to health, extremes of temperature.

1.5 Hazardous environment around the product

Consider: explosion risk areas, lack of oxygen (e.g. tanks, pits), dangerous gases, extremes of temperature, hot surfaces, fire hazard (e.g. during welding), excessive noise, moving machinery.

1.6 The system

Consider the effect on the complete system of the work proposed. Will any proposed action (e.g. closing isolation valves, electrical isolation) put any other part of the system or any personnel at risk? Dangers might include isolation of vents or protective devices or the rendering ineffective of controls or alarms. Ensure isolation valves are turned on and off in a gradual way to avoid system shocks.

1.7 Pressure systems

Ensure that any pressure is isolated and safely vented to atmospheric pressure. Consider double isolation (double block and bleed) and the locking or labelling of closed valves. Do not assume that the system has depressurised even when the pressure gauge indicates zero.

1.8 Temperature

Allow time for temperature to normalise after isolation to avoid danger of burns.

If parts made from PTFE have been subjected to a temperature approaching 260 °C (500 °F) or higher, they will give off toxic fumes, which if inhaled are likely to cause temporary discomfort. It is essential for a no smoking rule to be enforced in all areas where PTFE is stored, handled or processed as persons inhaling the fumes from burning tobacco contaminated with PTFE particles can develop 'polymer fume fever'.

1.9 Tools and consumables

Before starting work ensure that you have suitable tools and/or consumables available. Use only genuine Spirax Sarco replacement parts.

1.10 Protective clothing

Consider whether you and/or others in the vicinity require any protective clothing to protect against the hazards of, for example, chemicals, high/low temperature, radiation, noise, falling objects, and dangers to eyes and face.

1.11 Permits to work

All work must be carried out or be supervised by a suitably competent person.

Installation and operating personnel should be trained in the correct use of the product according to the Installation and Maintenance Instructions.

Where a formal 'permit to work' system is in force it must be complied with. Where there is no such system, it is recommended that a responsible person should know what work is going on and, where necessary, arrange to have an assistant whose primary responsibility is safety.

Post 'warning notices' if necessary.

1.12 Handling

Manual handling of large and/or heavy products may present a risk of injury. Lifting, pushing, pulling, carrying or supporting a load by bodily force can cause injury particularly to the back. You are advised to assess the risks taking into account the task, the individual, the load and the working environment and use the appropriate handling method depending on the circumstances of the work being done.

1.13 Residual hazards

In normal use the external surface of the product may be very hot. If used at the maximum permitted operating conditions the surface temperature of these products may reach temperatures of 260 °C (500 °F).

These products are not self-draining. Take due care when dismantling or removing the product from an installation (refer to 'Maintenance instructions').

1.14 Freezing

Provision must be made to protect products which are not self-draining against frost damage in environments where they may be exposed to temperatures below freezing point.

1.15 Disposal

Unless otherwise stated in the Installation and Maintenance Instructions, this product is recyclable and no ecological hazard is anticipated with its disposal providing due care is taken, with the exception of PTFE.

PTFE:

- Can only be disposed of by approved methods, not incineration.
- Keep PTFE waste in a separate container, do not mix it with other rubbish, and consign it to a landfill site.

1.16 Returning products

Customers and stockists are reminded that under EC Health, Safety and Environment Law, when returning products to Spirax Sarco they must provide information on any hazards and the precautions to be taken due to contamination residues or mechanical damage which may present a health, safety or environmental risk. This information must be provided in writing including Health and Safety data sheets relating to any substances identified as hazardous or potentially hazardous.

2. General product information

2.1 General description

The full bore two-piece body ball valves that are covered in this document have a floating ball as standard and are produced in accordance with API 6D. They have been designed for use as isolating valves, not control valves.

ISO mounting

As standard, all the valves in this document have an integral ISO body mounting which allows the valve to be automated without losing seal integrity, as the body does not require disassembly. Manual to remote control may therefore be easily accomplished by fitting a BVA300 series pneumatic actuator available from Spirax Sarco. For further details contact Spirax Sarco.

Available types and applications

M33F2 ISO	Has an API 607 firesafe design, zinc plated carbon steel body and PDR 0.8 seats (for high temperatures)
M33F3 ISO	Has an API 607 firesafe design, stainless steel body and PDR 0.8 seats (for high temperatures)
API 607 firesafe design - In normal working conditions, the ball rests against two PDR 0.8 seats ensuring total closure. When the valve is submitted to temperature above the limits the seats can withstand, the seat becomes deformed and renders to extrusion. When the seats have been totally destroyed, the ball will come to rest firmly against the metal seat in the cap, producing a metal-to-metal closing. This secondary seat in the valve cap ensures the valve will operate to international API 607 standards.	
Applications	Designed for use with the majority of industrial fluids on applications, which include steam, condensate, water, oil, gases, and other fluids within its operating range.
M33S2 ISO	Zinc plated carbon steel body and PDR 0.8 seats (for high temperatures)
M33S3 ISO	Stainless steel body and PDR 0.8 seats (for high temperatures)
Applications	Designed for use with the majority of industrial fluids on applications, which include steam, condensate, water, oil, gases, and other fluids within its operating range.
M33V2 ISO	Zinc plated carbon steel body and PTFE seats
M33V3 ISO	Stainless steel body and PTFE seats
Applications	Designed for use on applications at low temperatures which use natural gas and most of the hydrocarbon fluids in the OPC refinery sites.

Standards

This product fully complies with the requirements of the Pressure Equipment Directive (PED) and carries the  mark when so required.

Certification

These products are available with material certification to EN 10204 3.1.

Note: All certification/inspection requirements must be stated at the time of order placement.

2.2 Sizes and pipe connections

DN50, DN65, DN80, DN100, DN150 and DN200.

Standard flange ASME B 16.5 Class 150 and 300 with face-to-face dimensions according to B 16.10.

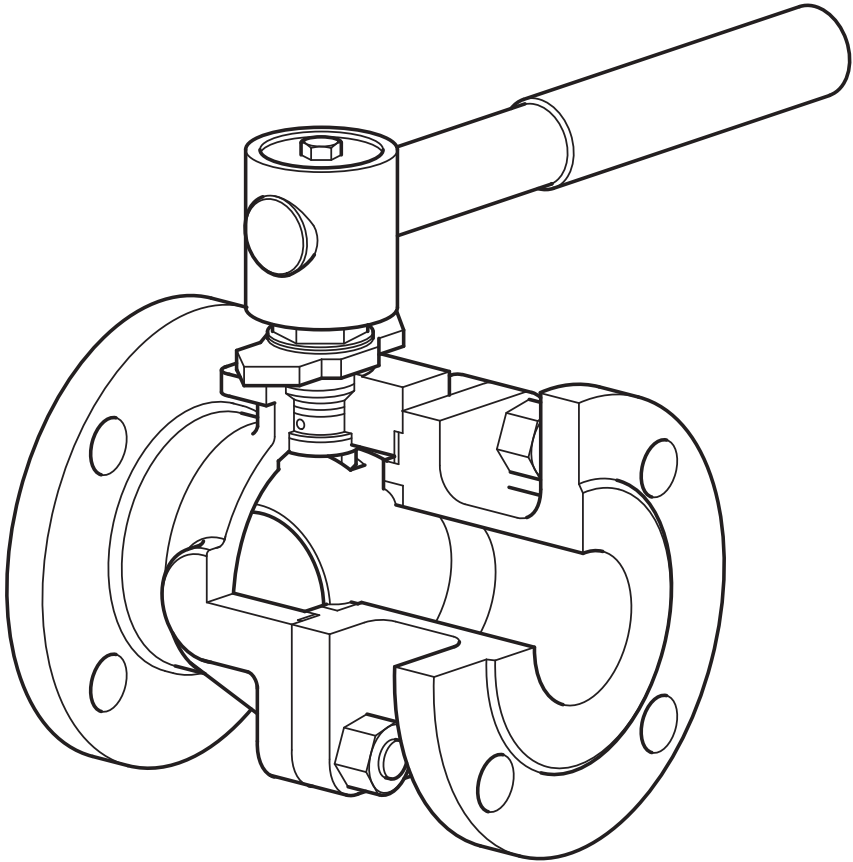
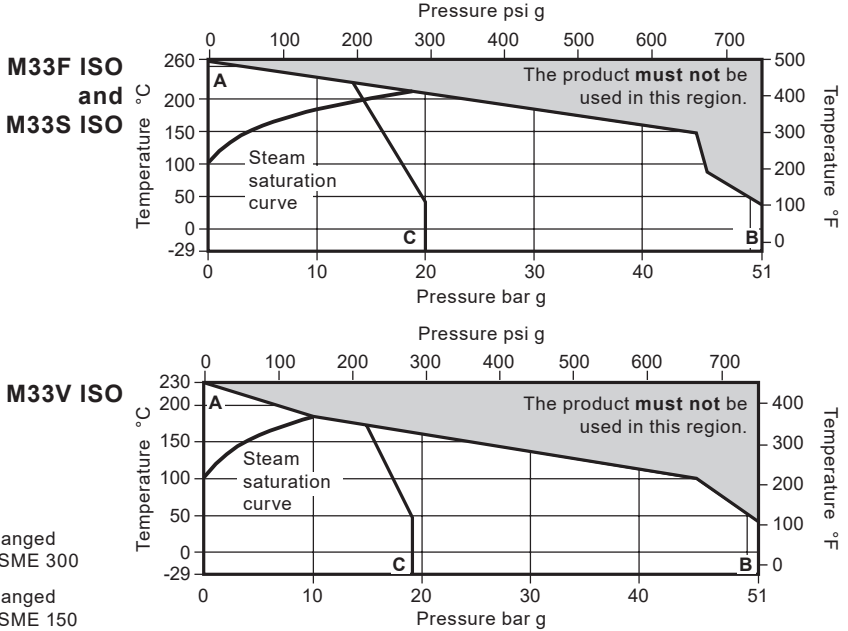

Fig. 1 M33_ ISO

2.3 Pressure/temperature limits



Body design conditions		ASME B 16.34	
PMA	Maximum allowable pressure	M33V ISO	ASME 150 19 bar g @ 38 °C 275 psi g @ 100 °F
		M33F ISO and M33S ISO	ASME 300 51 bar g @ 45 °C 740 psi g @ 113 °F
		M33F ISO and M33S ISO	ASME 150 20 bar g @ 38 °C 290 psi g @ 100 °F
		M33F ISO and M33S ISO	ASME 300 51 bar g @ 38 °C 740 psi g @ 100 °F
TMA	Maximum allowable temperature	M33V ISO	230 °C @ 0 bar g 446 °F @ 0 psi g
		M33F ISO and M33S ISO	260 °C @ 0 bar g 500 °F @ 0 psi g
Minimum allowable temperature		-29 °C	-20 °F
PMO	Maximum operating pressure for saturated steam service	M33V ISO	10 bar g 145 psi g
		M33F and M33S ISO	17.5 bar g 254 psi g
TMO	Maximum operating temperature	M33V ISO	230 °C @ 0 bar g 446 °F @ 0 psi g
		M33F ISO and M33S ISO	260 °C @ 0 bar g 500 °F @ 0 psi g
Minimum operating temperature		-29 °C	-20 °F
ΔPMX	Maximum differential pressure is limited to the PMO		
Designed for a maximum cold hydraulic test pressure of:	ASME 150	28.5 bar g	413 psi g
	ASME 300	76.5 bar g	1109 psi g

3. Installation

Note: Before actioning any installation observe the 'Safety information' in Section 1.

Although the valve has great structural integrity, severe misalignment and/or the pulling effect of incorrect pipe length will have a detrimental effect on the valve and must be avoided. Particular attention should be paid to correct pipe alignment such that the inlet pipework and valve are all on the same axis.

Valves are for on/off applications and may be operated manually. Wherever practicable, valves should be installed where there is adequate space available so that they can be conveniently operated and maintained.

Before installing a valve, check to ensure that size, pressure rating, materials of construction, end connections, etc. are suitable for the service conditions of the particular application.

Care must be taken to ensure that all dirt which may have accumulated in the valve during storage is removed before installation, maintain cleanliness during installation since the introduction of dirt can result in damage to the valve seats and operating mechanism.

To minimise the danger of abrasive particles damaging the seats, pipeline strainers should be fitted upstream of the valves.

Install the valve with the handle in a suitable position. The preferred position is with the spindle vertical. The valve can be installed in any position for gas service (see Figure 3 below).

When used on steam services:

- 1. Fit a trapped drain pocket upstream of the valve.
- 2. Open valve slowly to prevent the risk of waterhammer damage.

Do not mount the valve upside down for liquid service (Figure 2).

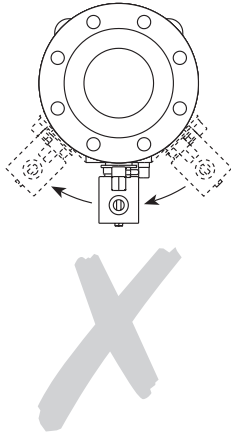

Fig. 2 Incorrect installation for liquid service

Valves should be installed into the pipeline in the fully closed position.

Always open valves slowly to avoid system shocks.

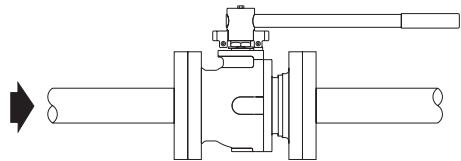
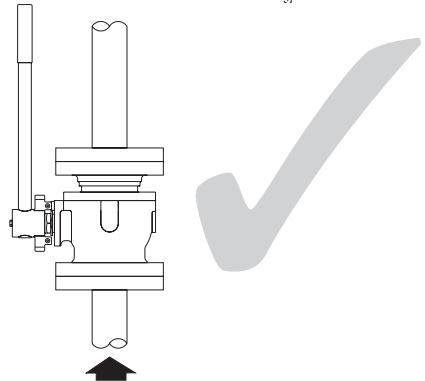
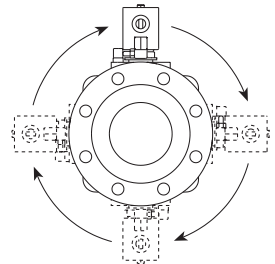

Fig. 3 Correct installation for gas service

4. Commissioning

After installation or maintenance ensure that the system is fully functioning. Carry out tests on any alarms or protective devices.

5. Operation

The valve is operated manually by a handle. Special care must be taken to ensure that the movement is made in the correct direction.

The valve can be used as an on/off valve, and can be operated fully open, or fully closed.

6. Maintenance

Note: Before actioning any maintenance programme observe the 'Safety information' in Section 1.

6.1 General information

As with all mechanical devices, regular maintenance is the most efficient means of ensuring continued operational efficiency.

Regular scheduled inspection of all valves is essential, especially on valves which are operated only occasionally.

6.2 General maintenance

Isolate the unit - Before removing the M33 ISO ball valve from the pipeline to action any maintenance work, isolate it both upstream and downstream and wait for the unit to reach ambient temperature before handling. The complete body assembly can then be removed and any new parts fitted - See Section 7.

6.3 How to replace the stem seats:

- Remove the ball valve from the pipeline observing the 'Safety information' in Section 1.
Warning: Isolate the ball valve both upstream and downstream and wait for the unit to reach ambient temperature before handling.
- Remove the nuts (20) from the studs (19) and split the main body (1) from the insert (2).
- Remove the seats (4) and the ball (3).
- Withdraw the stem (6) and replace the lower stem seal (7) and the 'O' ring (8).
- Reassemble the unit using a new body gasket (5). The nuts and studs (19, 20) and gland nut (13) should be tightened to the recommended torque, see Table 1, page 12.

Please note - When the seats and lower stem seal have been replaced and the valve has been reassembled it is advisable to conduct a cold hydraulic test to the valve body as follows:

- ASME 150 28.5 bar g (410 psi g)
- ASME 300 76.5 bar g (1010 psi g)

It is also advisable to conduct a seat leakage test using compressed air at 7 bar g (101 psi g).

After 24 hours in service, retighten nuts (20 and 13) and check for leaks.

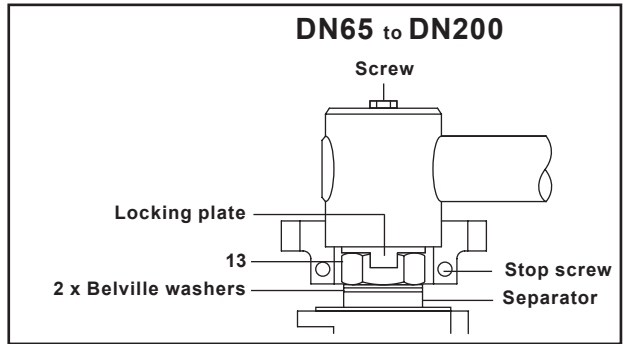

DN50 shown for the main illustration

Fig. 4 M33_ISO

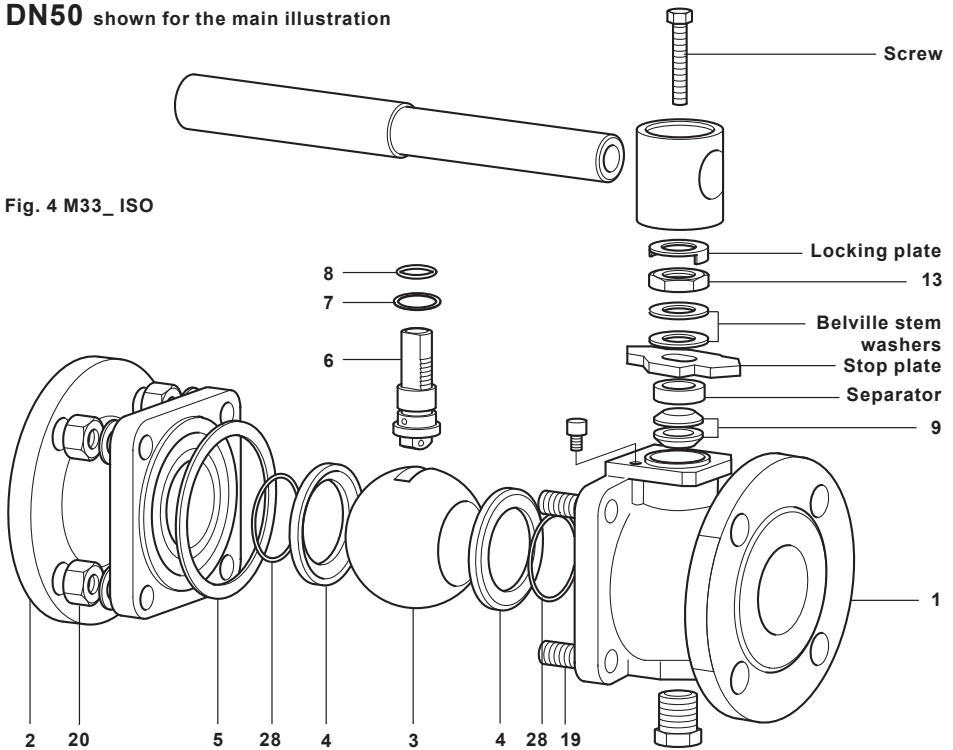

6.4 How to replace the upper stem packing:

- Observe the 'Safety information' in Section 1.
Warning: Isolate the ball valve both upstream and downstream and wait for the unit to reach ambient temperature before handling.
- Remove the gland nut (13).
- Replace the upper stem packing (9).
- Reassemble the unit and tighten the gland nut (13) to the recommended torque, see Table 1.

Please note - If leakage is observed through the stem, after 24 hours in service, it may be stopped by retightening the gland nut (13) to the recommended torque, see Table 1.

Table 1 Recommended tightening torques

Part	Size	N m		(lbf ft)	
		ASME 150	ASME 300	ASME 150	ASME 300
Studs (19) and Nuts (20)	DN50	60	140	44	103
	DN65	60	220	44	162
	DN80	60	220	44	162
	DN100	140	140	103	103
	DN150	140	220	103	162
	DN200	350	350	258	258
Gland nut (13)	DN50	30 - 40		22 - 30	
	DN65	54 - 61		40 - 45	
	DN80	54 - 61		40 - 45	
	DN100	76 - 90		56 - 66	
	DN150	196 - 216		145 - 159	
	DN200	196 - 216		145 - 159	

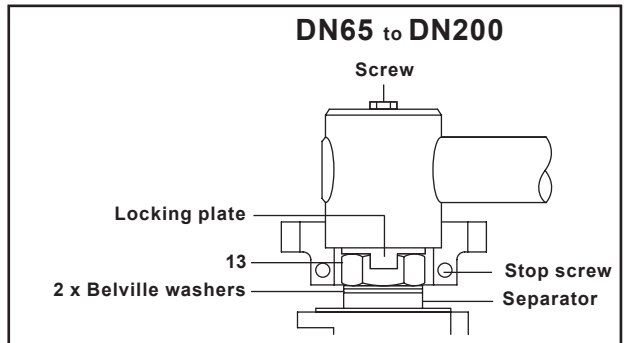

DN50 shown for the main illustration

Fig. 5 M33_ ISO

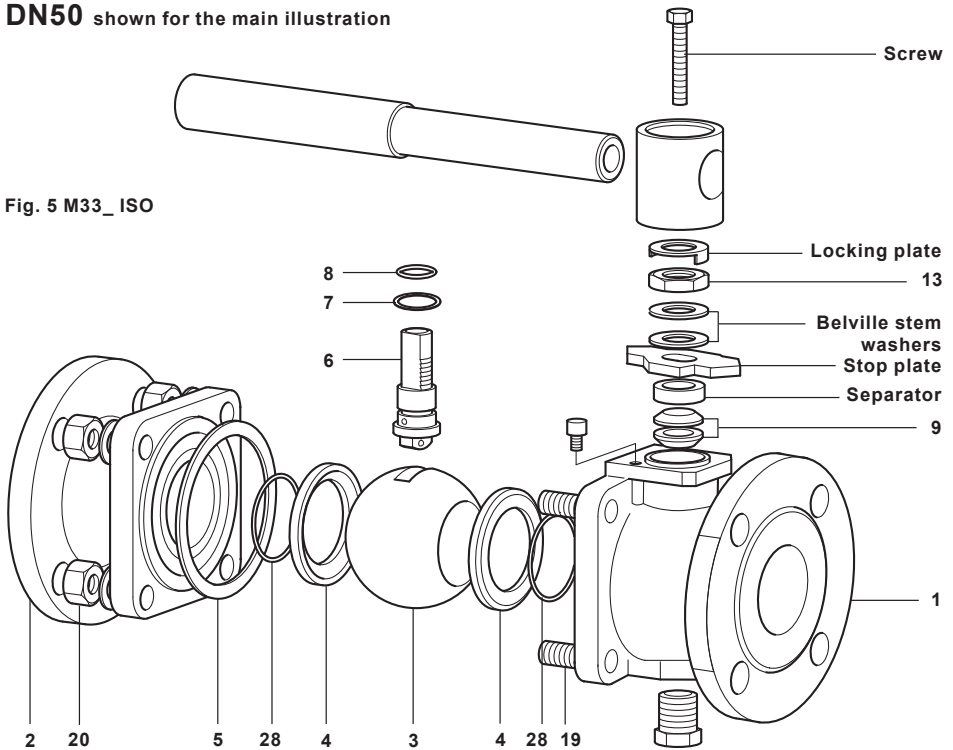

7. Spare parts

The spare parts available are shown in solid outline. Parts drawn in a grey line are not supplied as spares:

Seats, body gasket, stem seals, stem 'O' ring and seat 'O' ring set

4, 5, 7, 8, 9, 28

How to order spares

Always order spares by using the description given in the column headed 'Available spares' and state the size and type of ball valve.

Example: 1 - Seats, body gasket, stem seals and stem 'O' ring set for a Spirax Sarco DN80 flanged ASME 150 M33SV2 ISO ball valve.

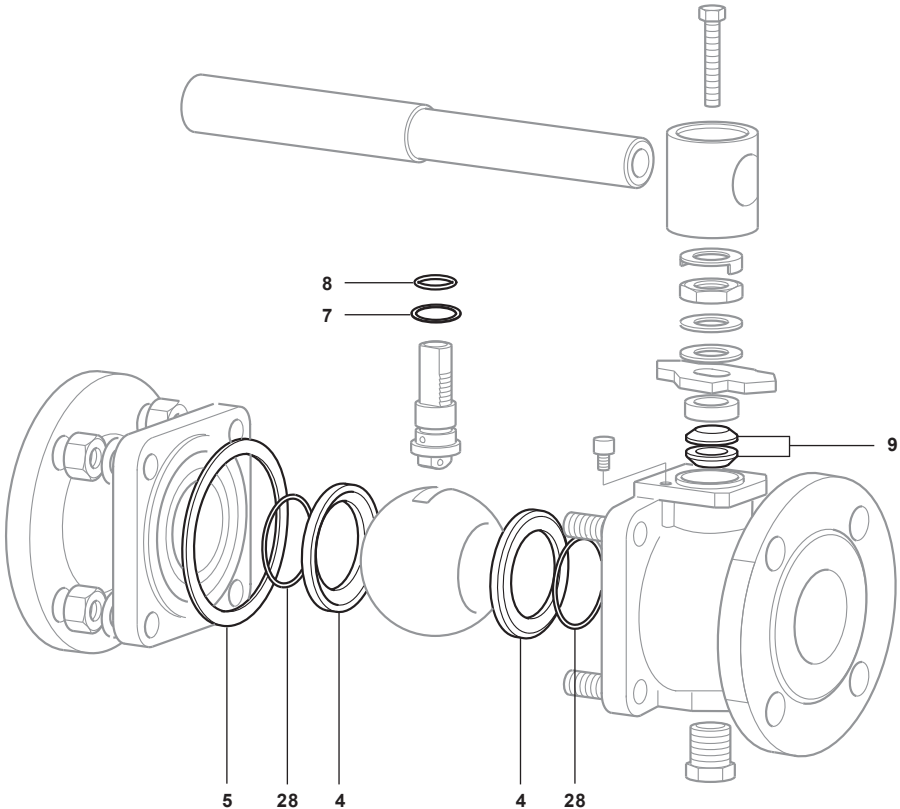

Fig. 6 M33_ ISO

