

M31 ISO Ball Valve

Installation and Maintenance Instructions

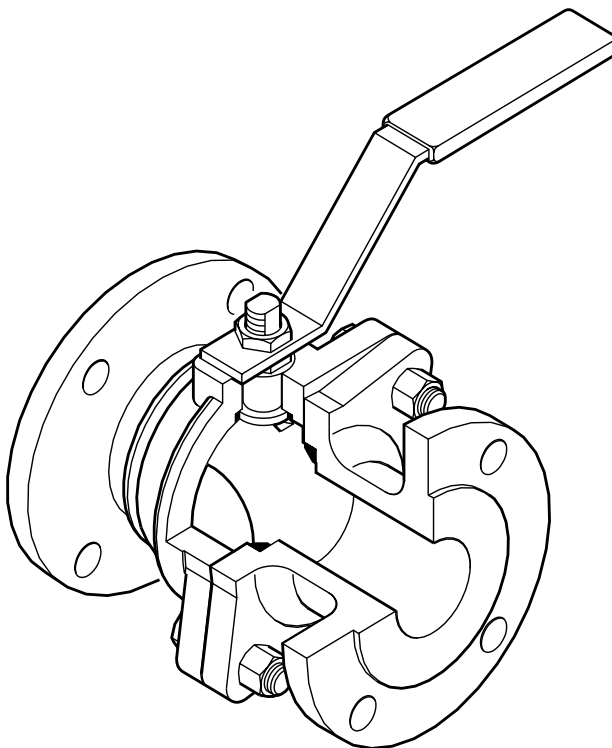

Safety information

Before commencing any dismantling work ensure that no flow is taking place in the pipeline; that the line is isolated elsewhere, or that the flow of the fluid is discontinued. Any fluid remaining in the line should be drained off before dismantling the valve.

Installation

Although the valve has great structural integrity, severe misalignment and/or the pulling effect of incorrect pipe length will have a detrimental effect on the valve and must be avoided. Particular attention should be paid to correct pipe alignment such that the inlet pipework and valve are all on the same axis.

Valves are for on/off applications and may be installed with flow in either direction. When used on steam services:

1. Fit a trapped drain pocket upstream of the valve.
2. Open the valve slowly to prevent the risk of waterhammer damage.

Maintenance

General

When seats are replaced and the valve is reassembled it is advisable to conduct a hydraulic test to the valve body as follows:

- PN16 24.0 bar g
- ANSI 150 28.5 bar g
- ANSI 300 76.5 bar g

It is also advisable to conduct a seat leakage test using compressed air at 7 bar g.

How to replace the main stem seats

WARNING:

If the old body gasket has been subjected to a temperature approaching 315°C or higher then it may have decomposed and formed hydrofluoric acid. Avoid skin contact and inhalation of any fumes as the acid will cause deep skin burns and damage the respiratory system.

1. Remove the valve from the line (see Safety information).
2. Remove the bolts (13) and split the main body and body connector (see Warning above).
3. Remove the seats (5) and the ball (3). Withdraw the stem and replace the main stem seal (7a).
4. Reassemble using a new body gasket (6). (See Warning above).
5. The bolts and nuts (13, 14) should be tightened to the torques shown in the Table opposite.

How to replace the secondary stem seals

1. Remove nuts (10)
2. Replace stem seals (7)

Note: If leakage is observed through the stem it may be stopped by tightening gland nut (10) without having to replace the stem seals. The gland nut (10) should be tightened to the torques shown in the Table opposite.

Spares

The spare parts available are shown in heavy outline. Parts drawn in broken line are not supplied as spares.

Available spares

Seat, body gasket and stem seal set **5, 6, 7, 7a**

How to order spares

Always order spares by using the description given in the column headed 'Available spares' and state the size and type of ball valve required.

Example: 1 - Seat, body gasket and stem seal set for DN80 M31V2 ISO ball valve.

Recommended tightening torques

Bolts and nuts

Item	Size	N m	
		PN16 ANSI 150	ANSI 300
13 and 14	DN50	175	445
	DN65	175	500
	DN80	175	500
	DN100	295	445
	DN150	445	445
	DN200	445	500

Gland nuts

Item	Size	N m
10	DN50	18 - 21
	DN65	54 - 61
	DN80	54 - 61
	DN100	76 - 90
	DN150	196 - 216
	DN200	375 - 415

