

M15 ISO Ball Valve
Screwed, SW, BW and flanged versions
Installation and Maintenance Instructions

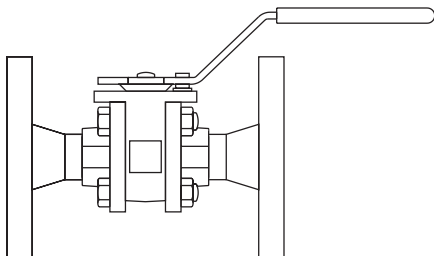

1. *General safety information*
2. *General product information*
3. *Installation*
4. *Commissioning*
5. *Operation*
6. *Maintenance*
7. *Spare parts*

— 1. *General safety information* —

Safe operation of the unit can only be guaranteed if it is properly installed, commissioned and maintained by a qualified person (see Section 11 of the attached Supplementary Safety Information) in compliance with the operating instructions. General installation and safety instructions for pipeline and plant construction, as well as the proper use of tools and safety equipment must also be complied with.

Isolation

Consider whether closing isolating valves will put any other part of the system or personnel at risk. Dangers might include; isolation of vents and protective devices or alarms. Ensure isolation valves are turned off in a gradual way to avoid system shocks.

Pressure

Before attempting any maintenance consider what is or may have been in the pipeline. Ensure that any pressure is isolated and safely vented to atmospheric pressure before attempting to maintain the product, this is easily achieved by fitting Spirax Sarco depressurisation valves type DV (see separate literature for details). Do not assume that the system is depressurised even when a pressure gauge indicates zero.

Temperature

Allow time for temperature to normalise after isolation to avoid the danger of burns and consider whether protective clothing (including safety glasses) is required.

Disposal

The product is recyclable. No ecological hazard is anticipated with the disposal of this product providing due care is taken.

— 2. General product information —

2.1 General description

M15 ISO is a three piece body ball valve design with metal seats. This makes it suitable for working with: Fluids that contain solids in suspension, high temperature fluids and flow control applications.

ISO mounting

The integral ISO body mounting allows the valve to be automated without losing seal integrity, as the body does not require disassembly. Manual to remote control may therefore be safely and easily accomplished by the ISO range of Spirax Sarco ball valves.

Available types

Note: The nomenclature will be followed with either **FB** (full bore) or **RB** (reduced bore) i.e. M153KRB ISO.

M152V__ISO Zinc plated carbon steel body, Viton 'O' ring.

M152K__ISO Zinc plated carbon steel body, Kalrez 'O' ring.

M153V__ISO Stainless steel body, Viton 'O' ring.

M153K__ISO Stainless steel body, Kalrez 'O' ring.

M154V__ISO Complete stainless steel, Viton 'O' ring.

M154K__ISO Complete stainless steel, Kalrez 'O' ring.

Note: For additional information see Technical Information Sheet, TI-P133-34.

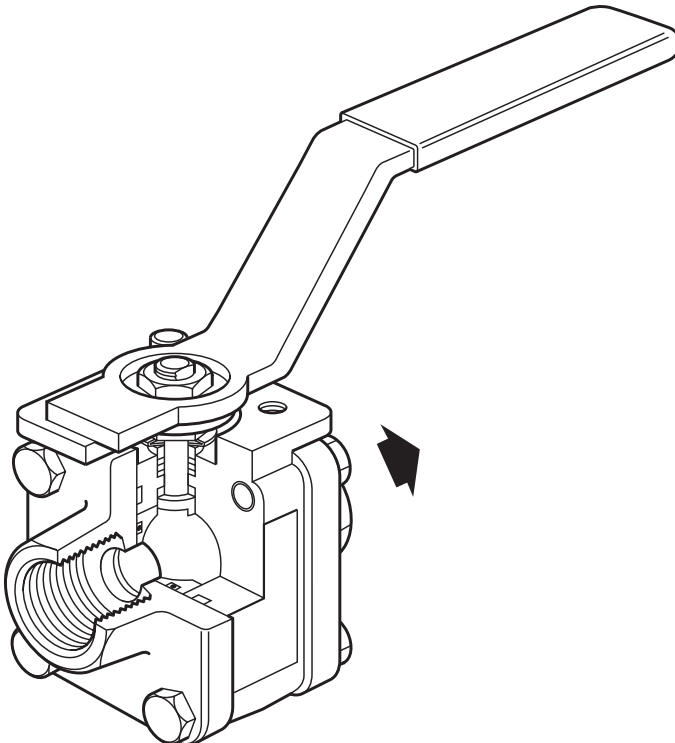

Fig. 1 M15 ISO ball valve

2.2 Sizes and pipe connections

1/4", 3/8", 1/2", 3/4", 1", 1 1/4", 1 1/2", 2", (2 1/2" only available with reduced bore).

Screwed BSP, BSPT, NPT, SW, BW full bore and reduced bore.

DN15 - 50 (DN65 only available with reduced bore).

Flanged ANSI 150 and ANSI 300, full bore and reduced bore.

Flanged DIN PN40, full bore and reduced bore.

2.3 Limiting conditions

Maximum operating temperature	M15V	220°C @ 21 bar g
	M15K	300°C @ 21 bar g
Maximum operating pressure	M15V	21 bar g @ 220°C
	M15K	21 bar g @ 300°C
Maximum saturation steam pressure		21 bar g
Designed for a maximum cold hydraulic test pressure of:		32 bar g

2.4 Operating range

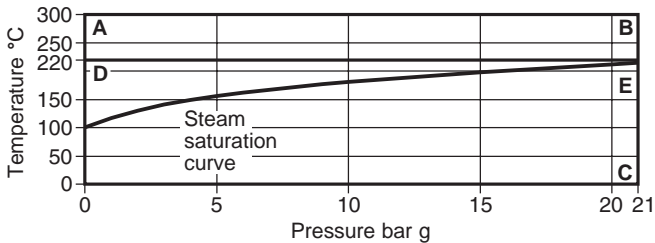

A - B - C M15_K using Kalrez 'O' ring.

D - E - C M15_V using Viton 'O' ring.

3. Installation

Note: Before actioning any installation observe the 'Safety information' in Section 1.

Although the valve has great structural integrity, severe misalignment and/or the pulling effect of incorrect pipe length will have a detrimental effect on the valve and must be avoided. Particular attention should be paid to correct pipe alignment such that the inlet pipework and valve are all on the same axis.

Valves are for both on/off and control applications and may be installed with flow in either direction. Wherever practicable, valves should be installed where there is adequate space available so that they can be conveniently operated and maintained.

Before installing a valve, check to ensure that size, pressure rating, materials of construction, end connections, etc. are suitable for the service conditions of the particular application.

Care must be taken to ensure that all dirt which may have accumulated in the valve during storage is removed before installation, maintain cleanliness during installation since the introduction of dirt can result in damage to the valve seats and operating mechanism.

To minimise the danger of abrasive particles damaging the seats, pipeline strainers should be fitted upstream of the valves.

Install the valve with the handle in a suitable position. The preferred position is with the spindle vertical. The valve can be installed from the vertical to the horizontal plane (see Fig. 2 below).

Do not mount the valve upside down (Fig. 3).



Fig. 3 Incorrect installation

When installed on steam systems a suitable steam trap should be fitted immediately upstream of the isolation valve. This will ensure drainage of the pipe when the valve is closed, and will prevent damage of the valve due to waterhammer. The drain trap should be either a ball float (FT) or thermodynamic (TD) type. Correct condensate drainage of all upstream pipework is also vital.

Valves should be installed into the pipeline in the fully closed position. Prior to welding into the pipeline, it will be necessary to:

1. Dismantle the end caps from the body.
2. Remove the stainless steel seat.
3. Weld each end cap to the pipeline.
4. Replace the stainless steel seats.
5. Reassemble.

Always open valves slowly to avoid system shocks.

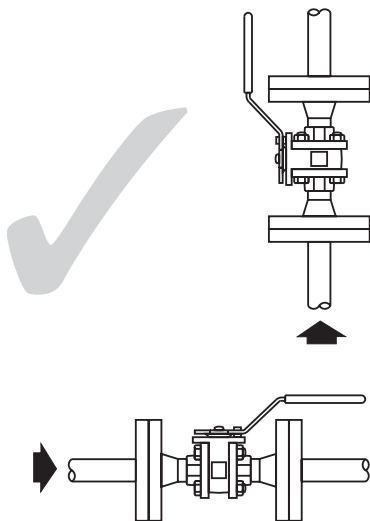

Fig. 2 Correct installation

4. Commissioning

After installation or maintenance ensure that the system is fully functioning. Carry out tests on any alarms or protective devices.

5. Operation

The valve is operated manually by a handle, or automatically by an actuator. Special care must be taken to ensure that the movement is made in the correct direction.

The valve can be used as an on/off valve or a modulation flow control valve, and can be operated fully open, fully closed, or any point in between.

6. Maintenance

Note: Before actioning any maintenance programme observe the 'Safety information' in Section 1.

6.1 General information

As with all mechanical devices, regular maintenance is the most efficient means of ensuring continued operational efficiency.

Regular scheduled inspection of all valves is essential especially on valves which are operated only occasionally.

6.2 General maintenance

Maintenance work can be carried out without removing the complete ball valve from the pipeline. Remove the four nuts (17) and bolts (16). The complete body assembly can then be removed and any new parts fitted.

Whenever the valve is dismantled, the graphite body gaskets (15) must be replaced before reassembly.

Flanged valves: To proceed with maintenance work, the complete flanged valve requires removal from the pipeline. Remove the four nuts (17) and withdraw the four bolts (16). The complete body assembly can now be removed and the new parts fitted.

6.3 To replace seats (5)

- Remove the body as described in Section 6.2.
- With body removed, remove seats (5).
- Fit new seats (5) and seat 'O' rings (14), pushing them into the body recesses.

6.4 To replace the ball

- With body and seats removed, remove the ball (3).
- Fit the new ball into the valve body.
- Fit the new seats and seat seals as described in 6.3, above.

6.5 To replace stem seals (6, 6A and 7)

- Remove body as described in Section 6.2.
- Remove nuts (10, 10A), and two Belleville washers (9).
- Replace stem seals (6, 6A and 7).

6.6 To replace body gasket (15)

- With body removed, remove the body gasket (15).
- Fit new body gaskets (15), pushing them into the body recesses.

6.7 Reassembly

Reassemble in reverse order to instructions given above. The securing bolts and nuts (16, 17) should be tightened to the recommended torques shown in Table 1 opposite.

After 24 hours in service, retighten body bolts.

7. Spare parts

The spare parts available are shown in heavy outline. Parts drawn in broken line are not supplied as spares.

Available spares

Ball	3
Seat, seals, 'O' ring and body gasket set	5, 6 and 6A, 7, 14, 15

How to order spares

Always order spares by using the description given in the column headed 'Available spares' and state the size and type of ball valve.

Example: 1 - Seat, seals, 'O' ring and body gasket set for a ½" M152VFB ISO ball valve.

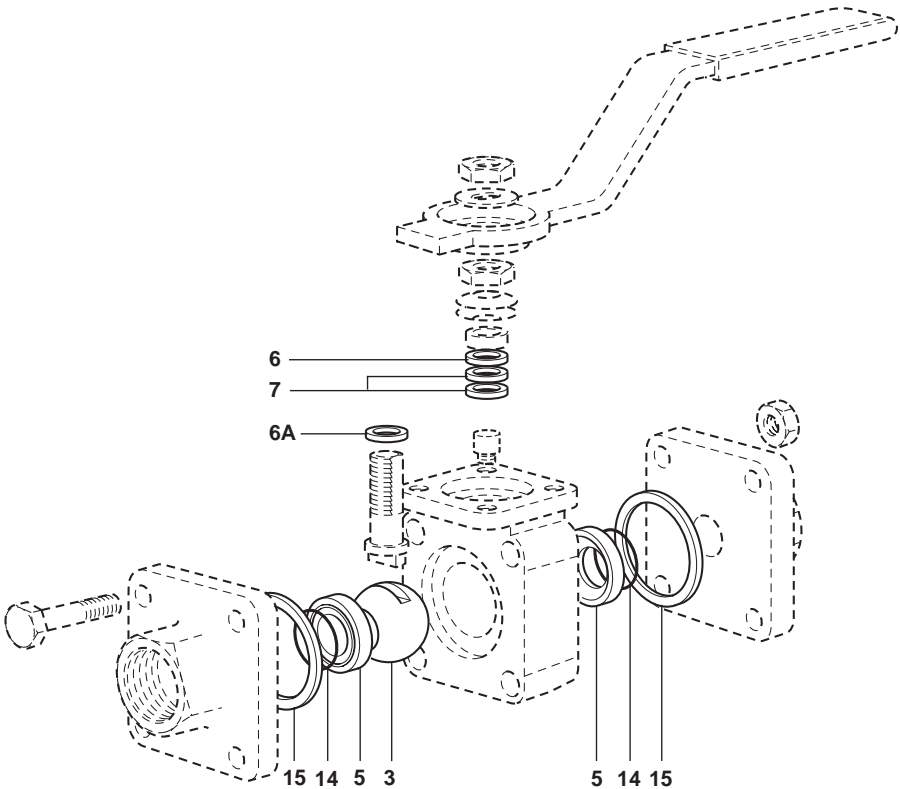

Fig. 5 ¼" - ¾" shown