

M10F and M10F ISO Ball Valve Screwed, SW and BW Versions Installation and Maintenance Instructions

The Spirax Sarco M10F and M10F ISO ball valves are a three piece design comprising of: Body and two end caps.

M10F
screwed version shown.

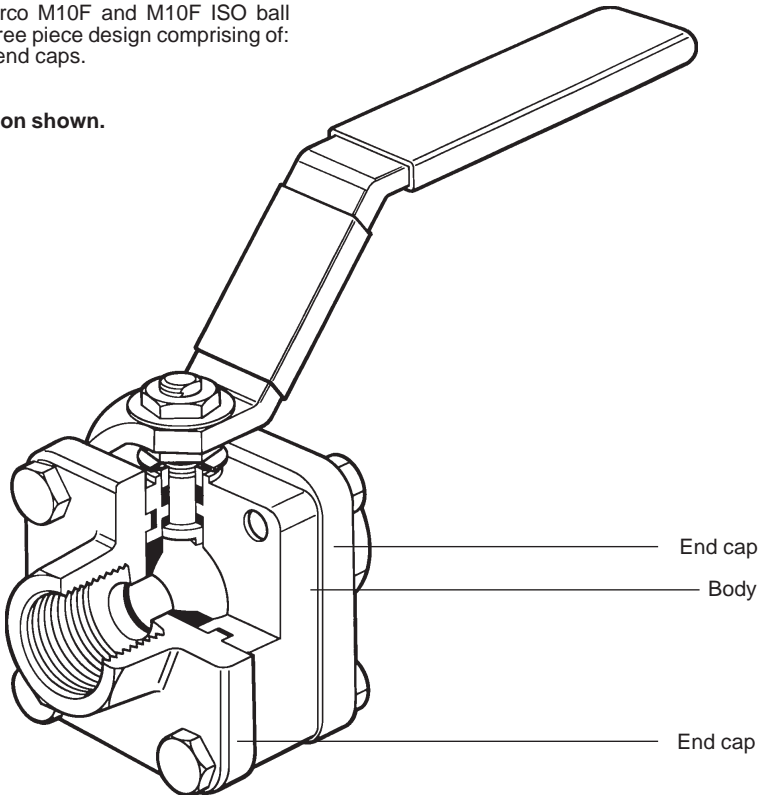

Installation

Although the valve has great structural integrity, severe misalignment and / or the pulling effect of incorrect pipe length will have a detrimental effect on the valve and must be avoided. Particular attention should be paid to correct pipe alignment such that the inlet pipework and valve are all on the same axis.

Valves are for on/off applications and may be installed with flow in either direction. When used on steam services:

1. Fit a trapped drain pocket upstream of the valve.
2. Open valve slowly to prevent the risk of waterhammer damage.

Socket and butt weld valves

Prior to any welding it will be necessary to:

1. Dismantle the end caps from the body.
2. Remove the R-PTFE seats.
3. Weld each end cap to the pipeline.
4. Replace the R-PTFE seats.
5. Reassemble.

Safety note

Before commencing any dismantling work ensure that no flow is taking place in the pipeline; that the line is isolated elsewhere, or that the flow of the fluid is discontinued. Any fluid remaining in the line should be drained off before dismantling the valve.

Maintenance

General

To fit new parts, remove the valve from the pipeline, and remove the eight coupling bolts (15). Remove the valve body and fit parts.

Whenever the valve is dismantled, the graphite stem seal and body gaskets (16, 17) must be replaced before reassembling.

To replace seats

1. Remove the body as described above.
2. With body removed, remove seats (5).
3. Fit new seats, pushing them into body recesses.

To replace stem seals

1. Remove body as described above.
2. Remove nuts (11) and (9), and two Belleville washers (8).
3. Replace stem seals (6, 16).

To replace body gasket

1. With body removed, just remove the body gaskets (17).
2. Fit new body gaskets, pushing them into body recesses.

Reassembly

Reassemble in reverse order to instructions given above. The securing bolts (15) should be tightened to the torques shown in the table opposite.

Spare parts

The spare parts available are shown in heavy outline. Parts drawn in broken line are not supplied as spares.

Available spare

Seat, stem seal set and body gaskets	5, 6, 16, 17
--------------------------------------	--------------

How to order spares

Always order spares by using the description given in the column headed Available Spare and stating the size and type of ball valve required.

Example: 1 - Seat, seat seal set and body gaskets for 1/2" M10F2FB ISO ball valve.

Recommended tightening torques Securing bolts

Item	Size	N m
15	1/4", 3/8", 1/2" RB	13
	1/2" FB, 3/4" RB	13
	3/4" FB, 1" RB	55
	1" FB, 1 1/4" RB	55
	1 1/4" FB, 1 1/2" RB	55
	1 1/2" FB, 2" RB	60
	2" FB, 2 1/2" RB	70

Stem nut

Item	Size	N m
9	1/4", 3/8", 1/2" RB	5.4 - 8.1
	1/2", 3/4" RB	5.4 - 8.1
	3/4" FB, 1" RB	10.8 - 13.5
	1" FB, 1 1/4" RB	17.5 - 20.3
	1 1/4" FB, 1 1/2" RB	17.5 - 20.3
	1 1/2" FB, 2" RB	17.5 - 20.3
	2" FB, 2 1/2" RB	40 - 47

