

LSB31, LSB32, LSB33, LSB34, LSB71, LSB72, LSB73 and LSB74 Limit Switch Boxes for BVA300 Series Actuators Installation and Maintenance Instructions

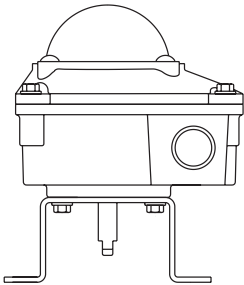

LSB31, LSB32, LSB33 and LSB34

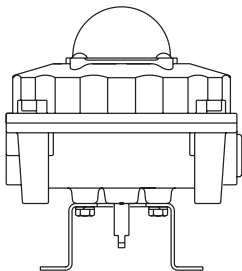

LSB71, LSB72, LSB73 and LSB74

1. Safety information
2. General product information
3. Installation
4. Wiring
5. Commissioning
6. Operation
7. Maintenance
8. Spare parts

1. Safety information

Safe operation of this product can only be guaranteed if it is properly installed, commissioned, used and maintained by qualified personnel (see Section 1.11) in compliance with the operating instructions. General installation and safety instructions for pipeline and plant construction, as well as the proper use of tools and safety equipment must also be complied with. Isolate the mains supply before carrying out any work on the switch box.

1.1 Intended use

Referring to the Installation and Maintenance Instructions, name-plate and Technical Information Sheet, check that the product is suitable for the intended use/application. These products comply with the requirements of the Pressure Equipment Directive (PED) and carry the  mark when so required.

- i) Verify the limit switch box name plate to insure the respective unit has the correct mechanical, inductive or pneumatic sensors. This is important as different switch boxes have different internals.
- ii) Check material suitability, pressure and temperature and their maximum and minimum values. If the maximum operating limits of the product are lower than those of the system in which it is being fitted, or if malfunction of the product could result in a dangerous overpressure or overtemperature occurrence, ensure a safety device is included in the system to prevent such over-limit situations.
- iii) Spirax Sarco products are not intended to withstand external stresses that may be induced by any system to which they are fitted. It is the responsibility of the installer to consider these stresses and take adequate precautions to minimise them.
- iv) Remove protection covers from all connections and protective film from all name-plates, where appropriate, before installation on steam or other high temperature applications.

1.2 Access

Ensure safe access and if necessary a safe working platform (suitably guarded) before attempting to work on the product. Arrange suitable lifting gear if required

1.3 Lighting

Ensure adequate lighting, particularly where detailed or intricate work is required.

1.4 Hazardous liquids or gases in the pipeline

Consider what is in the pipeline or what may have been in the pipeline at some previous time. Consider: flammable materials, substances hazardous to health, extremes of temperature.

1.5 Hazardous environment around the product

Consider: explosion risk areas, lack of oxygen (e.g. tanks, pits), dangerous gases, extremes of temperature, hot surfaces, fire hazard (e.g. during welding), excessive noise, moving machinery.

1.6 The system

Consider the effect on the complete system of the work proposed. Will any proposed action (e.g. closing isolation valves, electrical isolation) put any other part of the system or any personnel at risk?

Dangers might include isolation of vents or protective devices or the rendering ineffective of controls or alarms. Ensure isolation valves are turned on and off in a gradual way to avoid system shocks.

1.7 Pressure systems

Ensure that any pressure is isolated and safely vented to atmospheric pressure. Consider double isolation (double block and bleed) and the locking or labelling of closed valves. Do not assume that the system has depressurised even when the pressure gauge indicates zero.

1.8 Temperature

Allow time for temperature to normalise after isolation to avoid danger of burns.

1.9 Tools and consumables

Before starting work ensure that you have suitable tools and / or consumables available. Use only genuine Spirax Sarco replacement parts.

1.10 Protective clothing

Consider whether you and/or others in the vicinity require any protective clothing to protect against the hazards of, for example, chemicals, high / low temperature, radiation, noise, falling objects, and dangers to eyes and face.

1.11 Permits to work

All work must be carried out or be supervised by a suitably competent person.

Installation and operating personnel should be trained in the correct use of the product according to the Installation and Maintenance Instructions.

Where a formal 'permit to work' system is in force it must be complied with. Where there is no such system, it is recommended that a responsible person should know what work is going on and, where necessary, arrange to have an assistant whose primary responsibility is safety.

Post 'warning notices' if necessary.

1.12 Handling

Manual handling of large and/or heavy products may present a risk of injury. Lifting, pushing, pulling, carrying or supporting a load by bodily force can cause injury particularly to the back. You are advised to assess the risks taking into account the task, the individual, the load and the working environment and use the appropriate handling method depending on the circumstances of the work being done.

1.13 Residual hazards

In normal use the external surface of the product may be very hot. If used at the maximum permitted operating conditions the surface temperature of this product may reach temperatures of 100 °C (212 °F).

This product is not self-draining. Take due care when dismantling or removing the product from an installation (refer to 'Maintenance instructions').

1.14 Freezing

Provision must be made to protect products which are not self-draining against frost damage in environments where they may be exposed to temperatures below freezing point.

1.15 Disposal

Unless otherwise stated in the Installation and Maintenance Instructions, this product is recyclable and no ecological hazard is anticipated with its disposal providing due care is taken.

1.16 Returning products

Customers and stockists are reminded that under EC Health, Safety and Environment Law, when returning products to Spirax Sarco they must provide information on any hazards and the precautions to be taken due to contamination residues or mechanical damage which may present a health, safety or environmental risk. This information must be provided in writing including Health and Safety data sheets relating to any substances identified as hazardous or potentially hazardous.

2. General product information

2.1 General description

LSB limit switch boxes are normally used for indicating valve open or valve closed position. They also allow switching points to be adjustable over the full range of actuators. There is an open/closed valve position indicator mounted at the end of the switch box axis, at the top of the cover. LSB's include a stainless steel linkage kit for direct mounting to BVA300 series actuators.

Available limit switch boxes:

LSB31	Contact switches (2 x SPDT)
LSB71	Contact switches (2 x SPDT) Explosion proof Exd IIC T6
LSB32	10 - 30 Vdc 3-wire proximity sensors (2 x Autonics PS17-5DNU, NPN)
LSB72	10 - 30 Vdc 3-wire proximity sensors (2 x Autonics PS17-5DNU, NPN) Explosion proof Exd IIC T6
LSB33	8 Vdc 2-wire proximity sensors (2 x P&F NJ2-V3-N; intrinsically safe)
LSB73	8 Vdc 2-wire proximity sensors (2 x P&F NJ2-V3-N; intrinsically safe) Explosion proof Exd IIC T6
LSB34	5 - 60 Vdc 2-wire proximity sensors (2 x P&F NBB3-V3-Z4)
LSB74	5 - 60 Vdc 2-wire proximity sensors (2 x P&F NBB3-V3-Z4) Explosion proof Exd IIC T6

Note: For further information on this product see Technical Information sheet TI-P372-26.



Fig. 1 LSB31, LSB32, LSB33 and LSB34

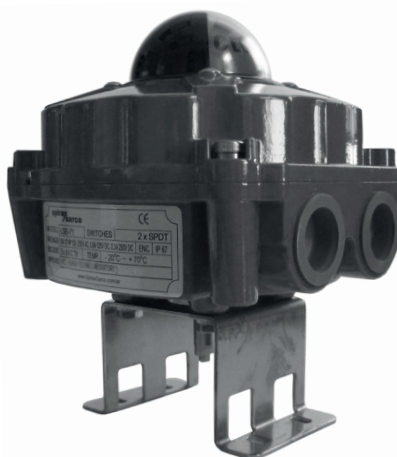

Fig. 2 LSB71, LSB72, LSB73 and LSB74

LSB31, LSB32, LSB33, LSB34, LSB71, LSB72, LSB73 and LSB74 Limit Switch Boxes for BVA300 Series Actuators

2.2 Technical data

	Standard	Optional
Protection	LSB3_ IP67	IP68
	LSB7_ Explosion proof Exd IIC T6, IP67	IP68
Outer cover	Epoxy - polyester	Nylon
Room temperature	-20 °C to +80 °C	-40 °C to +100 °C
Connection socket	8 terminals	
Position indicator	0° to 90° dome type	3-way L-port, T-port
Mounting kit	NAMUR, SS1 or SS2 stainless steel	SS3, MT1
Switch sensor	Mechanical 2-SPDT	LSB3_ Proximity sensors - P&F Autonics, Magnetic
		Magnetic sensor
Switch sensor	Mechanical 2-SPDT	DPDT switches
		LSB7_ Proximity sensors - P&F Autonics, Magnetic
Switch sensor	Mechanical 2-SPDT	Magnetic sensors
		Position transmitter (output 0-1 Kohm, 4-20 mA dc)
Case	Cast aluminum	Stainless steel 316L *
Nomenclature	LSB3_	LSB7_S
	LSB7_	LSB7_S

* Stainless Steel case not available for LSB3_

3. Installation

Note: Before actioning any installation observe the 'Safety information' in Section 1.

3.1 General installation

The box is supplied with a stainless steel mounting bracket, which may be mounted on any actuator having a NAMUR VDI/VDE 3845 interface.

- Manually turn the box shaft to align it with the actuator before engaging the drive shaft.
- Fasten the box to the actuator using the bolts provided.

3.2 Cam adjustment - If required

All units are supplied with 0° - 90° cam adjustment:

- Loosen the 4 cover screws and remove the cover.
- Readjust the cams to the position required.

4. Wiring

Caution - The following instructions must be carried out carefully to maintain the validity of the IP rating:

- Remove the cover to introduce the cable through the gland and connect the wires to the terminal strip according to the electrical wiring sticker on the external side of the LSB unit.
- Reassemble the lid after carefully placing the gasket between the cover and the box enclosure.
- Tighten the gland closer.

Mechanical switch

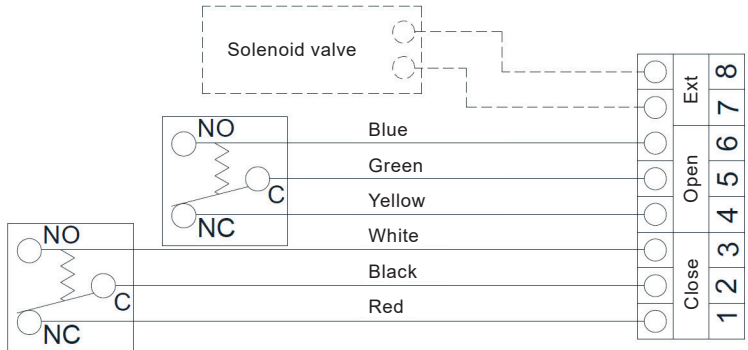
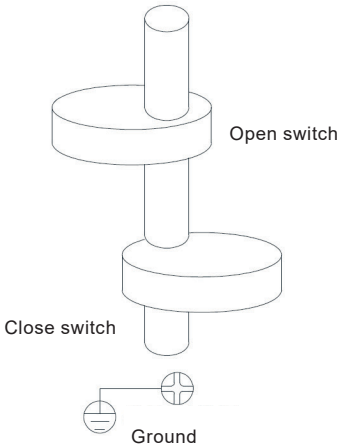

Fig. 3 LSB31
(for other sensors contact Spirax Sarco)

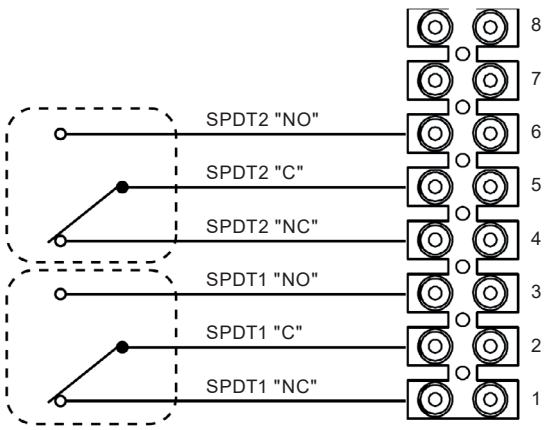
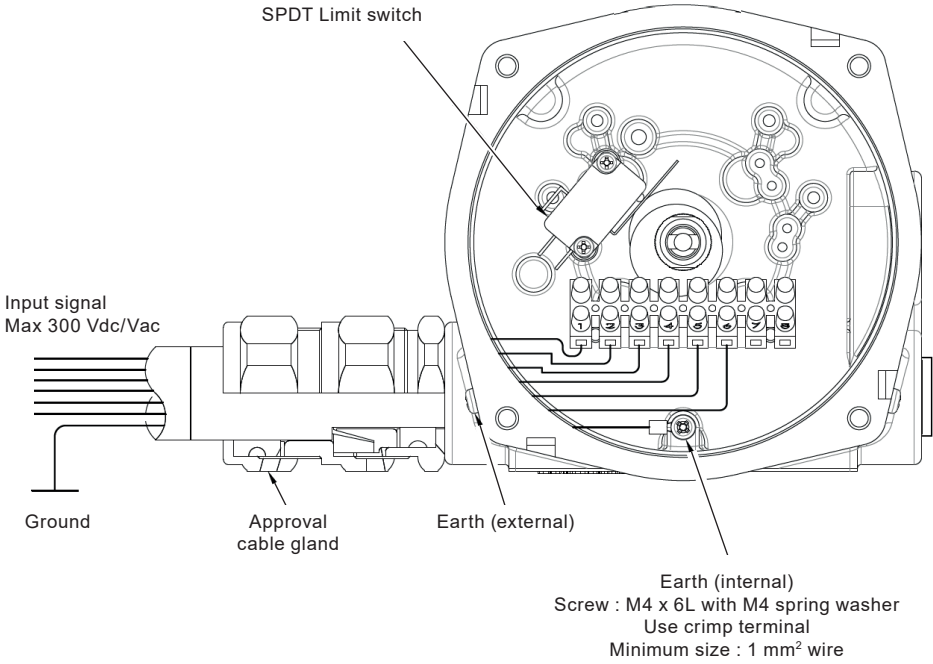

Fig. 4 LSB71
(for other sensors contact Spirax Sarco)

5. Commissioning

After installation or maintenance ensure that the system is fully functioning. Carry out tests on any alarms or protective devices.

6. Operation

LSB limit switch boxes are normally used for indicating valve open or valve closed position. They also allow switching points to be adjustable over the full range of actuators.

7. Maintenance

No maintenance is required. Switch setting can be checked periodically.

8. Spare parts

There are no available spare parts for these units.

