

## Type LRV2 Pressure Reducing Valve for Liquids Installation and Maintenance Instructions

### Sizes and pipe connections

½", ¾", 1" Screwed BSP (BS 21 Rp) or NPT.

LRV2B - Gunmetal body, screwed connections, with phosphor bronze / brass bellows.

LRV2S - Gunmetal body, screwed connections, with stainless steel bellows.

### Limiting conditions

Maximum upstream conditions 14 bar g.

Maximum downstream pressure 8.6 bar g.

The Spirax Sarco LRV2 liquid pressure reducing valve is supplied with one of three colour coded spring ranges:

Grey 0.35 - 1.7 bar g

Green 1.40 - 4.0 bar g

Orange 3.50 - 8.6 bar g

This information is located on the adjustment knob coloured insert (Q). Check that the LRV2 has the correct spring range for your application.

### Recommended Installation

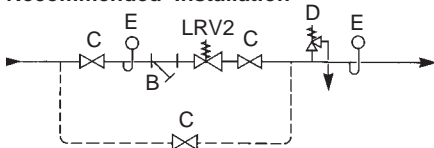

### Installation

The unit should always be fitted in a horizontal pipeline, but the adjustment head may be vertically above or below the valve. Isolating valves, upstream and downstream, should be installed with a clear run of 8 -10 diameters on either side of the LRV2. It is important that line stresses, caused by expansion or inadequate pipe support, are not imposed on the valve body. The piping on both the inlet and outlet connections of the valve must be of ample size to avoid creating undue pressure drop in the line. Fitting a strainer in the upstream supply will give additional protection to the valve. A pressure gauge is essential in the downstream pipework to allow setting of the operating pressure, and it is an advantage to have a similar gauge on the upstream side of the valve as well.

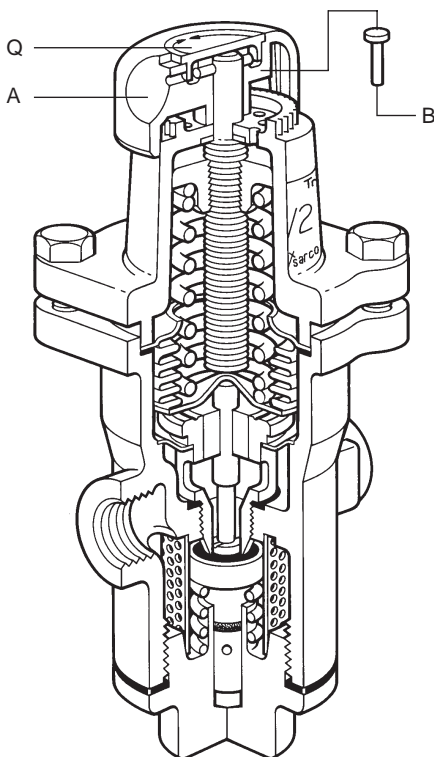

### Adjustment

Pressure changes are made by turning the adjustment knob (A) clockwise to increase pressure, and anti-clockwise to reduce pressure. (Before changing pressure ensure that the Tamper-proof Pin (B) has not been fitted, see section on Fitting Spares.

### Setting pressure

Slacken off the adjustment by turning the knob fully anti-clockwise. Open the isolating valves. The downstream pressure should be set with the normal running load passing through the valve. Turn the adjustment knob clockwise until the required pressure is obtained. Under reduced flow conditions the downstream pressure will rise, but will control at a pressure slightly higher than that set under the 'normal running load'.

## Safety note

Care should be exercised when handling gaskets since the stainless steel reinforcing strip can easily inflict cuts.

### Maintenance

The valve and seat must be kept clean. Any strainer fitted upstream of the LRV2, and the inbuilt strainer screen, should be cleaned regularly so that the flow through the valve is not restricted.

### Fitting spares

Before carrying out any work on the valve, ensure that it is fully isolated.

#### To clean strainer.

Release adjustment spring pressure by turning adjustment knob (A) fully anti-clockwise. Remove bottom cap (W) using 32mm A/F spanner. This will release piston assembly and screen. Clean screen. If piston face (nitrile) needs cleaning, use a soft cloth (non-abrasive). Reassemble, using new cap gasket (S) and tighten to 65/75 Nm.

#### To fit new valve seat and piston assembly.

Release adjustment spring pressure by turning knob fully anti-clockwise. Remove spring housing and main control spring, by undoing 4 hexagon bolts (G). Lift out bellows assembly (E) and gasket (F). Using 30mm A/F socket spanner, unscrew seat (L) with gasket (M) and bulkhead plate (R). Remove bottom cap (as for cleaning strainer above). Replace new seat assembly and gasket, and bulkhead plate, with the sensing hole towards the valve inlet port. Tighten the seat assembly to 108/132 Nm. Replace the bellows assembly, with a new gasket. Replace the main control spring and springing housing, and tighten the 4 bolts to 18/24 Nm. Fit new screen, piston and 'O' ring and return spring. Replace cap and new gasket(S) and tighten cap to 65/75 Nm.

**Note:** When refitting or replacing the piston or the 'o' ring these items should be lubricated with a non-toxic, non-melting water resistant silicone grease (e.g. ROCOL MX22).

#### To fit replacement pressure adjustment spring.

Release adjustment spring pressure by turning knob (A) fully anti-clockwise. Remove spring housing by undoing 4 bolts (G). Replace spring and spring housing, replace bolts and tighten to Nm 18/24.

#### To fit new bellows.

Release adjustment spring pressure by turning knob fully anti-clockwise. Remove spring housing by unscrewing 4 bolts. Lift out bellows assembly and gasket (F).

Replace bellows gasket and bellows, adjustment spring and spring housing and replace and tighten bolts to Nm 18/24.

#### To make LRV2 tamper-proof.

When the required set pressure has been achieved, lift out the coloured (Grey, Green or Orange) adjustment knob insert (Q), using a small screwdriver blade under the edge of the insert. A small loose pin (B) will be found in the recess in the adjustment knob (A). This pin is inserted into the locking hole (C) and into one of a ring of 10 matching holes in the top of the spring housing. Replace the adjustment knob insert, which will lock the pin in position.

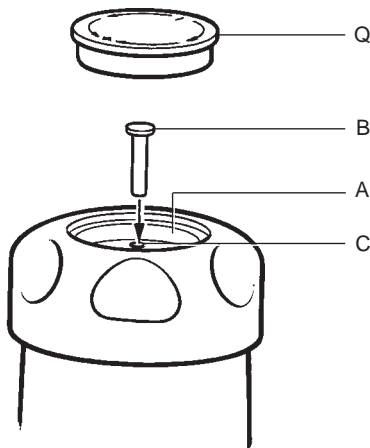

## Spare Parts

The spare parts available are shown in heavy outline. Parts drawn in broken outline are not supplied as spares.

### AVAILABLE SPARES

* Pressure adjustment spring			
Grey	0.35 - 1.7 bar g	D,Q	
Green	1.40 - 4.0 bar g	D,Q	
Orange	3.50 - 8.6 bar g	D,Q	
* Bellows assembly - phosphor bronze E,F (Stainless steel optional 316 Ti/316L)			
* Spring housing bolts (set of 4)			G
Piston and seat assembly			
1/2"	F,K,L,M,R,S,T,U,V		
3/4" & 1"	F,K,L,M,R,S,T,U,V		
* Gasket set		F,M,S	
* Screen		T	
* Common to all sizes			

### How to order

Always order spares by using the description given in the column headed Available Spares and stating the size, type and pressure range of the reducing valve.

**Example:1** - Pressure Adjustment Spring, pressure range 3.5/8.6 bar g (orange) for 3/4" BSP Spirax Sarco type LRV2 reducing valve.

