

**LP41**  
**High Integrity,**  
**Self-monitoring High Water Level Alarm Probe**  
Installation and Maintenance Instructions

---

---

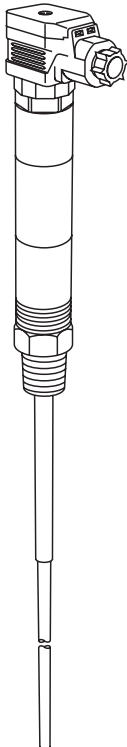

1. Safety information
2. General product information
3. Installation
4. Wiring
5. Maintenance
6. Technical assistance



# 1. Safety information

Your attention is drawn to any National or local regulations.

The product is designed and constructed to withstand the forces encountered during normal use. Use of the product for any other purpose, or failure to install the product in accordance with these Installation and Maintenance Instructions, could cause damage to the product and may cause injury or fatality to personnel.

The LP41 level probe and LCS3051 level switch comply with the requirements of the Pressure Equipment Directive (PED) and carry the  mark. They are classed as Safety Accessories and therefore fall within Category 4 of the Directive.

## Warning

If this product is not used in the manner specified by this IMI, then the protection provided may be impaired.

### 1.1 Intended use

The Level probe LP41 is designed for use in conjunction with the Spirax Sarco high water level switch LCS3051 and level switch LCS1350. If used in conjunction with other controllers then a safety power supply unit that delivers a Safety Extra Low Voltage (SELV) must be used to supply the controller/probe.

- i) The products have been specifically designed for use on steam and water, which are in Group 2 of the above mentioned Pressure Equipment Directive. The products' use on other fluids may be possible but, if this is contemplated, Spirax Sarco should be contacted to confirm the suitability of the product for the application being considered.
- ii) Check material suitability, pressure and temperature and their maximum and minimum values. If the maximum operating limits of the product are lower than those of the system in which it is being fitted, or if malfunction of the product could result in a dangerous overpressure or overtemperature occurrence, ensure a safety device is included in the system to prevent such over-limit situations.
- iii) Determine the correct installation situation and direction of fluid flow.
- iv) Spirax Sarco products are not intended to withstand external stresses that may be induced by any system to which they are fitted. It is the responsibility of the installer to consider these stresses and take adequate precautions to minimise them.
- v) Remove protection covers from all connections and protective film from all name-plates, where appropriate, before installation on steam or other high temperature applications.

### 1.2 Access

Ensure safe access and if necessary a safe working platform (suitably guarded) before attempting to work on the product. Arrange suitable lifting gear if required.

### 1.3 Lighting

Ensure adequate lighting, particularly where detailed or intricate work is required.

## 1.4 Hazardous liquids or gases in the pipeline

Consider what is in the pipeline or what may have been in the pipeline at some previous time. Consider: flammable materials, substances hazardous to health, extremes of temperature.

## 1.5 Hazardous environment around the product

Consider: explosion risk areas, lack of oxygen (e.g. tanks, pits), dangerous gases, extremes of temperature, hot surfaces, fire hazard (e.g. during welding), excessive noise, moving machinery.

## 1.6 The system

Consider the effect on the complete system of the work proposed. Will any proposed action (e.g. closing isolation valves, electrical isolation) put any other part of the system or any personnel at risk? Dangers might include isolation of vents or protective devices or the rendering ineffective of controls or alarms. Ensure isolation valves are turned on and off in a gradual way to avoid system shocks.

## 1.7 Pressure systems

Ensure that any pressure is isolated and safely vented to atmospheric pressure. Consider double isolation (double block and bleed) and the locking or labelling of closed valves. Do not assume that the system has depressurised even when the pressure gauge indicates zero.

## 1.8 Temperature

Allow time for temperature to normalise after isolation to avoid danger of burns.

## 1.9 Tools and consumables

Before starting work ensure that you have suitable tools and/or consumables available. Use only genuine Spirax Sarco replacement parts.

## 1.10 Protective clothing

Consider whether you and/or others in the vicinity require any protective clothing to protect against the hazards of, for example, chemicals, high/low temperature, radiation, noise, falling objects, and dangers to eyes and face.

## 1.11 Permits to work

All work must be carried out or be supervised by a suitably competent person. Installation and operating personnel should be trained in the correct use of the product according to the Installation and Maintenance Instructions. Where a formal 'permit to work' system is in force it must be complied with. Where there is no such system, it is recommended that a responsible person should know what work is going on and, where necessary, arrange to have an assistant whose primary responsibility is safety. Post 'warning notices' if necessary.

## 1.12 Handling

Manual handling of large and/or heavy products may present a risk of injury. Lifting, pushing, pulling, carrying or supporting a load by bodily force can cause injury particularly to the back. You are advised to assess the risks taking into account the task, the individual, the load and the working environment and use the appropriate handling method depending on the circumstances of the work being done.

### 1.13 Residual hazards

In normal use the external surface of the product may be very hot. Many products are not self-draining. Take due care when dismantling or removing the product from an installation.

### 1.14 Freezing

Provision must be made to protect products which are not self-draining against frost damage in environments where they may be exposed to temperatures below freezing point.

### 1.15 Safety information - Product specific for level control and level limit switch/alarm products in steam boilers

Products/systems must be selected, installed, operated, and tested in accordance with:

- Local or National standards and regulations.
- Guidance Notes, (Health and Safety Executive BG01 and INDG436 in the UK).
- The requirements of Approvals Authorities.
- Boiler Insurance Bodies.
- Boiler manufacturer's specifications.

The boiler must be depressurised and vented to atmosphere before installation of the probe.

Two low water level probes must be installed on steam boilers. The controller alarm relays must disconnect the boiler heat supply at low alarm status. Low level probes must be installed in separate protection tubes/chambers, with sufficient clearance between the tips, and earth ( $\geq 14$  mm). A combination of low water level probe and a level probe or high water level probe together in one protection tube/chamber is possible as well (check local regulations).

A high water alarm may be part of the water level control, or a separate system. An independent high water alarm system must be fitted if it is considered a safety requirement. In this case, the relays must simultaneously isolate the feedwater supply and the boiler heat supply at high alarm status. All boiler water limit switches alarms require regular functional testing.

Under certain circumstances the water level in a boiler can be different to that shown in the gauge glass.

Separate literature is available from Spirax Sarco on this subject.

Do not install the probe outdoors without additional weather protection.

Drain/vent holes must be kept clear - do not cover.

A suitable water treatment regime must be used to ensure continuous safe and correct operation of the control and alarm systems. Consult the above authorities and a competent water treatment company.

### 1.16 Disposal

Unless otherwise stated in the Installation and Maintenance Instructions, this product is recyclable and no ecological hazard is anticipated with its disposal providing due care is taken.

## 1.17 Returning products

Customers and stockists are reminded that under EC Health, Safety and Environment Law, when returning products to Spirax Sarco they must provide information on any hazards and the precautions to be taken due to contamination residues or mechanical damage which may present a health, safety or environmental risk. This information must be provided in writing including Health and Safety data sheets relating to any substances identified as hazardous or potentially hazardous.

Safe operation of these products can only be guaranteed if they are properly installed, commissioned, used and maintained by qualified personnel (see Section 1.11) in compliance with the operating instructions. General installation and safety instructions for pipeline and plant construction, as well as the proper use of tools and safety equipment must also be complied with.

The boiler must be depressurised and vented to atmosphere before installation of the probe.

Wherever possible the boiler manufacturer should be consulted for advice on the working and alarm water levels.

Under certain circumstances the water level in a boiler can be different to that shown in the gauge glass.

Separate literature is available from Spirax Sarco on this subject.

Do not install the probe outdoors without additional weather protection.

Drain/vent holes must be kept clean - do not cover.

## 2. General product information

### 2.1 General description

The Spirax Sarco LP41 is designed for use with an LCS3051 level limit switch to provide a high-integrity, self-monitoring alarm for high water levels in steam boilers and other vessels.

The probe is supplied in three nominal tip lengths, and is cut to the exact length required prior to installation.

The LP41 can also be used as a simple (non self-monitoring) high or low level probe with a suitable level switch.

### 2.2 Available tip lengths mm (in)

500 (19.7), 1000 (39.4) and 1500 (59).

**Please note** that the probe is normally installed vertically, but for probe tip lengths of up to 500 mm (20") it may be inclined by up to 45° from the vertical.

### 2.3 Limiting conditions

Maximum boiler pressure	32 bar g	(464 psi g)
Maximum temperature	239 °C	(462 °F)
Maximum ambient temperature	70 °C	(158 °F)
Maximum probe cable length	See level switch IMI	
Degree of protection	IP54	

### 2.4 How the LP41 works

#### LP41 used as a high water alarm with a LCS3051 level limit switch:

In normal operation as a high level alarm probe:

- The tip is above the water level.
- There is a high resistance path to earth.

**If the water level rises to touch the probe tip:**

- The resistance path to earth becomes low.
- The alarm relays in the level limit switch are de-energised.
- The high alarm sounds.

The integrity of the LP41 and its wiring are monitored by the LCS3051 limit switch, and an alarm is signalled if a fault occurs. The LP41 can also be used as a simple (non self-monitoring) high or low level probe with an LCS1350 level switch.

The LP41 connected to LCS1350 works in the same way, (low resistance in water, high resistance out of water), **but its integrity is not monitored.**

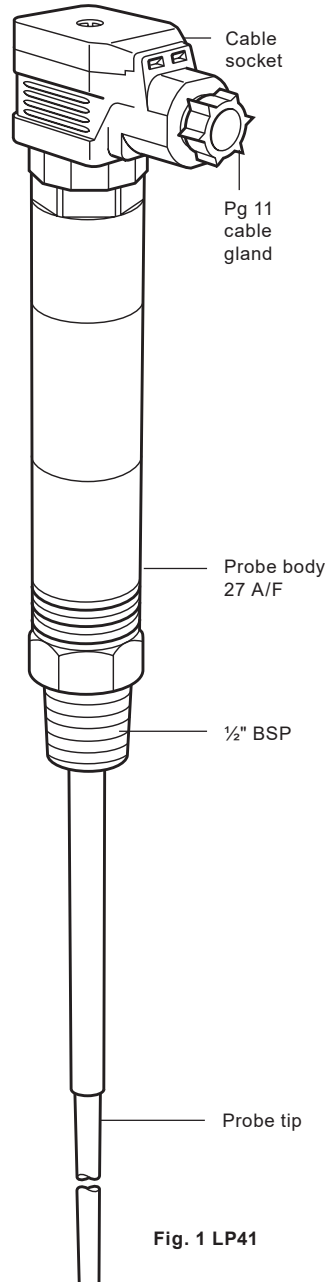

Fig. 1 LP41

LP41 High Integrity, Self-monitoring High Water Level Alarm Probe

# 3. Installation

**Before proceeding with any installation or maintenance read Section 1, 'General safety information'.**

The probe is normally installed directly in the boiler shell, in a protection tube of at least 80 mm (3") diameter, but can be mounted in an external chamber if regulations permit. The switching level is at the extreme end of the tip. See installation examples in Figures 2 and 3.

A DIN 43650 cable socket is supplied with each unit and is provided with a Pg 11 cable gland.

In most shell boilers the water will 'swell' when it is firing, such that the actual water level will be higher than the level shown in the gauge glass. In practice this can be up to 50 mm (2") in very large boilers, reducing to about 10 mm (1") in smaller ones. This difference in levels needs to be taken into consideration when cutting the probe tip to length.

When the probe is to be installed in the boiler, ensure it is positioned at least 1 metre (39") from any safety valve or steam take-off, as increased localised water levels may occur. Please note that the probe is normally installed vertically, but for probe tip lengths of up to 500 mm (20") it may be inclined by up to 45° from the vertical.

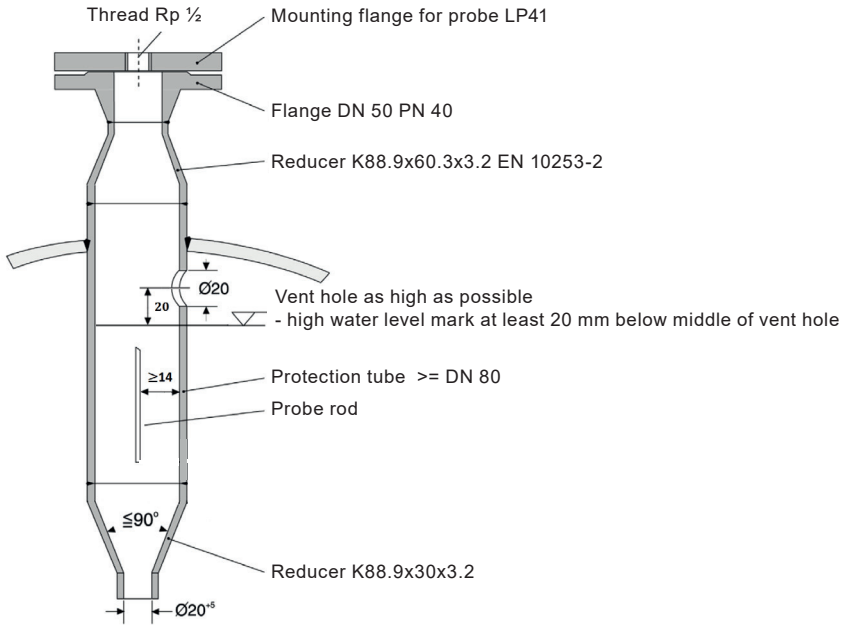

**Fig. 2 Installation example 1: Inside the boiler with protection tube provided by the customer**



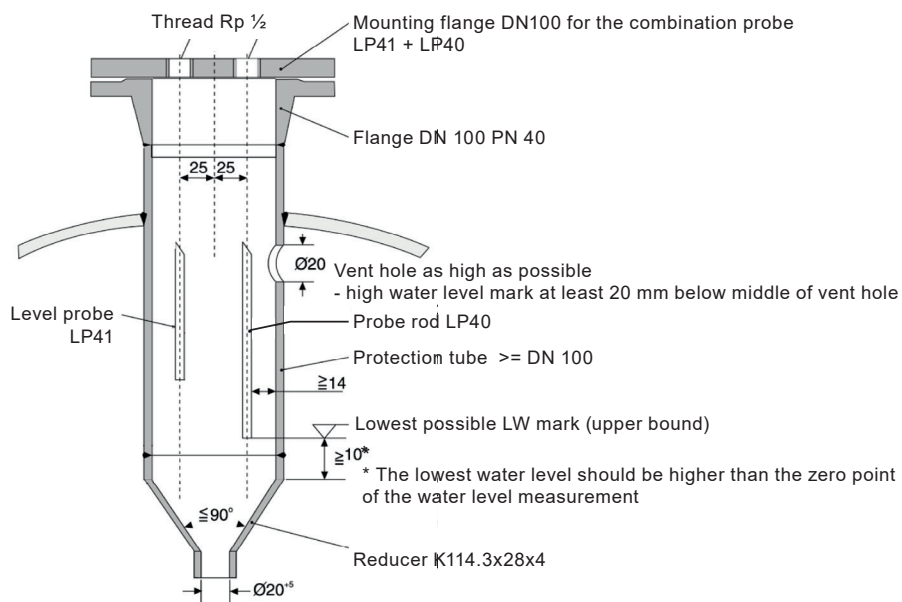

Fig. 3 Installation example 2: Combination with water level limiter probe LP40

## 3.1 Procedure

### 3.1.1 Caution:

It is essential that the PTFE probe tip sleeving is not damaged during probe tip cutting.

- Ensure the water is at the required alarm level, including any increase in level due to 'swelling'.
- Mark a metal rod with a water soluble felt pen, and dip the boiler to find the depth from the top of the probe mounting flange to the water level. Alternatively, obtain this depth by transferring the level from the gauge glass.
- Measuring from the underside of the probe body, cut the probe tip to 15 mm (½") less than the dipped length with a fine hacksaw and de-burr the end. See Figure 4. This takes the thread engagement into account.

**Note:** The minimum sleeved probe length is 30 mm (1 1/2"), and the minimum exposed tip length 40 mm (1 1/2"). Install the probe in a ½" BSP female connection.

### 3.1.2 Install the probe as follows:

- Ensure both male and female threads are in good condition.
- Use up to three turns (no more) of PTFE thread sealing tape on the probe thread.
- **WARNINGS: Do not use excessive tape. Do not use paste type jointing compound.**
- Fit and tighten the probe by hand initially - use a suitable spanner to tighten the probe. Under no circumstances use a pipe wrench.
- Due to the nature of a taper/parallel joint it is not possible to recommend tightening torque figures.
- Do not overtighten - there should always be visible thread on the probe.
- **Note:** The probe thread will not 'bottom out' (i.e. probe body hexagon contacts the face of the female screwed connection), unless there is excessive wear or an out-of-tolerance female thread, in which case it will be necessary to replace or re-work the flange or connection.

### 3.1.3 Subsequent removal and refitting:

**WARNING: Ensure boiler or vessel is de-pressurised and vented to atmosphere before attempting to unscrew or remove the probe.**

- Always use the correct size spanner - not a pipe wrench.
- Inspect male and female threads for signs of damage, which may have occurred through overtightening, leading to torn threads or even localised cold welding (galling/picking up).
- If damage has occurred replace the probe.

Fig. 4 Installation

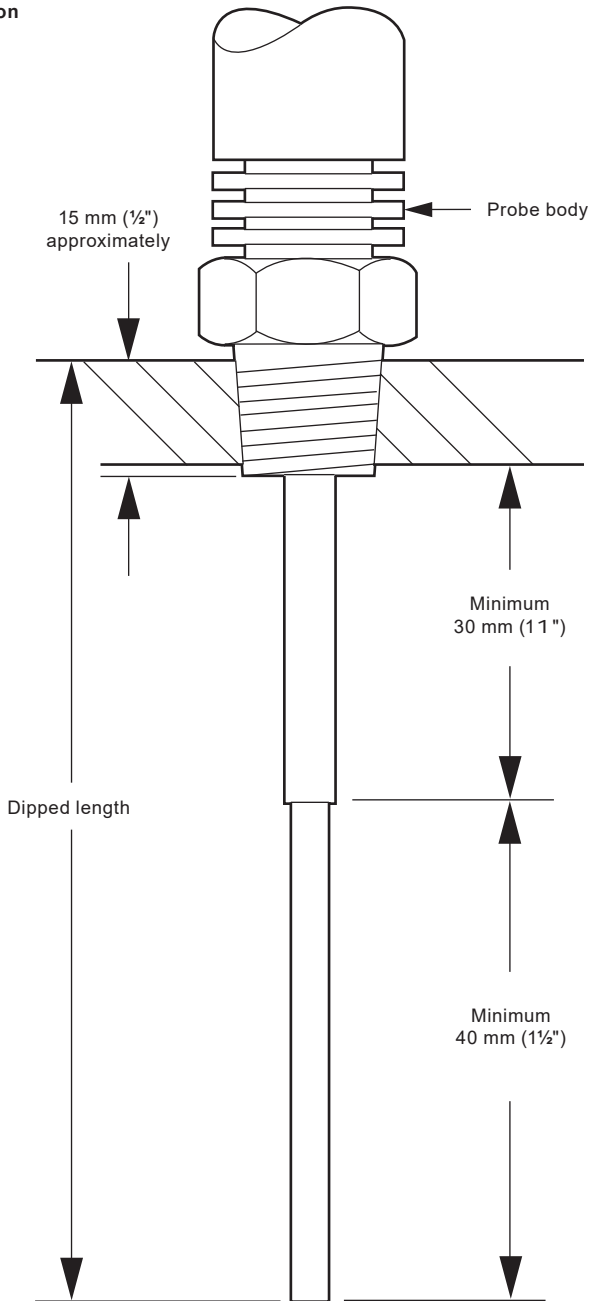

LP41 High Integrity, Self-monitoring High Water Level Alarm Probe

## 4. Wiring

Refer to the relevant level limit switch documentation/wiring diagram for full details.

Cabling should be installed in accordance with BS 6739 - Instrumentation in Process Control Systems: Installation design and practice or local equivalent. For the US and Canadian installations the probe must be wired in accordance with the National and Local Electrical Code (NEC) or the Canadian Electrical Code (CEC). The connector accepts wires with conductor cross section of 0.5 - 1.5 mm<sup>2</sup> (20 - 16 AWG). See controller IMI for details.

Ensure that sufficient cable length is provided to allow removal of the cable socket and to ensure that no strain is placed on the unit.

To unplug the cable socket, remove the central screw.

**Note: To provide environmental protection the probe is supplied with a gasket between the cable socket and the probe connector. To maintain environmental integrity, ensure gasket is always present when reconnecting cable socket and all contact surfaces are clean and undamaged.**

To gain access to the connector block within the cable socket, remove the central screw and withdraw the hinged cover.

**The connector block on the LP41 maybe rotated in 90° steps to facilitate wiring:**

- Remove the retaining screw and withdraw the socket.
- Remove connector block and reposition as required.

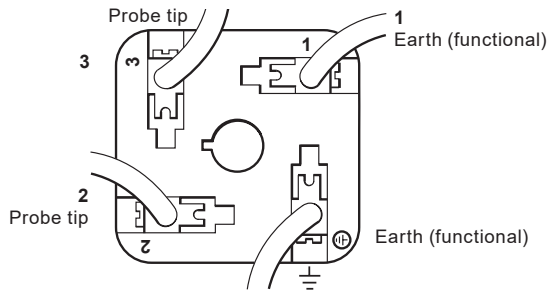
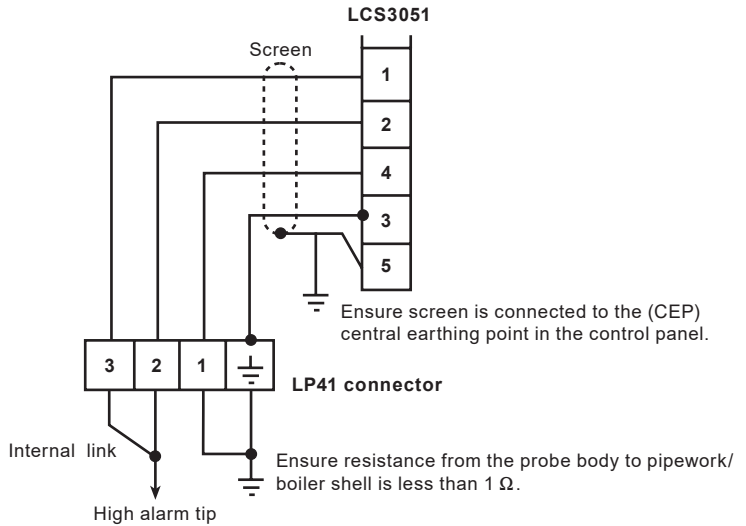
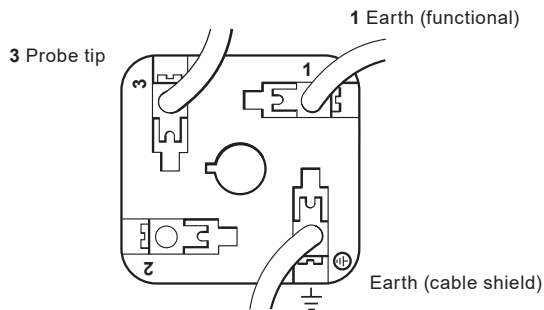

Fig. 5

**Connector block removed from cable connector. Wired for use with an LCS3051 level limit switch as a high integrity, self-monitoring high level probe.**



**Fig. 6**  
LCS3051 level limit switch



**Fig. 7**  
Connector block removed from cable connector. Wired for use as a simple (non-self monitoring) high or low level probe (e.g. LCS1350 level controller)

# 5. Maintenance

**Probe body cleaning instructions** - Use a cloth dampened with tap/de-ionised water or isopropyl alcohol. Use of other cleaning materials could damage the product and invalidate the warranty.

**Frequent maintenance of the probe should not be necessary.** However steam boiler water level controls do require regular testing in accordance with National and Regional regulations, and in the UK, Guidance Notes published by the Health and Safety Executive.

The UK Health and Safety Executive recommends that boiler controls should be inspected at least at quarterly intervals. We recommend that this frequency is also followed outside the UK unless National or Regional regulations state otherwise.

Where regular tests are carried out properly in a well run boiler house with good water treatment, it may be that only an annual inspection of the probe is required.

This is a matter, however, for the user to decide in liaison with the boiler inspector in order to determine a sensible inspection programme to suit the individual boiler plant.

**We recommend that the inspection is carried out as follows:**

- Depressurise and vent boiler/vessel, - observe safety precautions.
- Disconnect the electrical supply to level limit switch.
- Remove probe upper housing and inspect for dirt or moisture.
- Disconnect wiring and remove probe.
- Clean housing if necessary.
- Check condition of probe.
- Clean probe tips and insulation if necessary with a cloth or soft bristle brush - **do not** use abrasive or conductive products such as steel wool.

## **WARNING**

**If scale is present on the probe, it will also be forming on the boiler, and a competent water treatment specialist must be consulted as soon as possible.**

- Check that all extension connector lock-nuts are tight.
- Inspect the probe limit switch wiring, and the limit switch supply wiring.
- Check the limit switch for damage.
- Reassemble and carry out a full functional check of the equipment.

**For specific testing instruction for Spirax Sarco systems please see separate literature.**

## 6. Technical assistance

Contact your local Spirax Sarco representative. Details can be found on accompanying order/delivery documentation or on our web site:

**[www.spiraxsarco.com](http://www.spiraxsarco.com)**

### **Returning faulty equipment**

Return all items to your local Spirax Sarco representative. Ensure all items are suitably packed for transit (preferably in the original cartons).

### **Please provide the following information with any equipment being returned:**

1. Your name, company name, address and telephone number, order number and invoice and return delivery address.
2. Description and serial number of equipment being returned.
3. Full description of the fault or repair required.
4. If the equipment is being returned under warranty, please indicate:
  - a. Date of purchase.
  - b. Original order number.

**Spirax Sarco Ltd**  
Runnings Road  
Cheltenham  
GL51 9NQ  
United Kingdom

**[www.spiraxsarco.com](http://www.spiraxsarco.com)**

---

LP41 High Integrity, Self-monitoring High Water Level Alarm Probe