

KBV21i and KBV40i

Key Operated Boiler Blowdown Valves

Installation and Maintenance Instructions

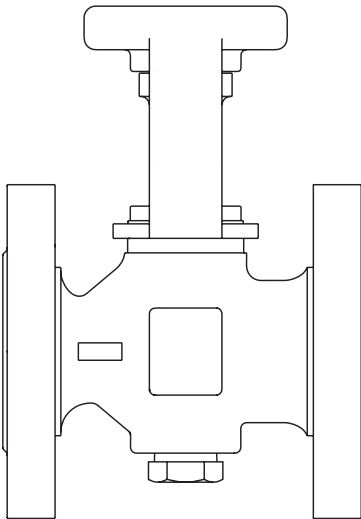

1. Safety information
2. General product information
3. Installation
4. Commissioning
5. Operation
6. Maintenance
7. Spare parts

1. Safety information

Safe operation of this product can only be guaranteed if it is properly installed, commissioned, used and maintained by qualified personnel (see Section 1.11) in compliance with the operating instructions. General installation and safety instructions for pipeline and plant construction, as well as the proper use of tools and safety equipment must also be complied with.

WARNINGS

Before commencing any dismantling work on a boiler, depressurise, drain, and vent the boiler to atmosphere.

Pipelines must be adequately isolated, depressurised, and drained. Isolation valves must be turned on and off gradually to avoid system shocks.

Ball valves can trap pressurised media in the body, so make sure there is no pressure to the valve body, or any pressure remaining in the body, before loosening or removing the flange bolts.

Maximum supply pressure	8 bar g (116 psi g)
-------------------------	---------------------

1.1 Intended use

Referring to the Installation and Maintenance Instructions, name-plate and Technical Information Sheet, check that the product is suitable for the intended use / application.

The products listed below comply with the requirements of the European Pressure Equipment Directive 2014/68/EU and carry the  mark when so required.

The products fall within the following Pressure Equipment Directive categories:

Product	Group 2 Gases	Group 2 Liquids	
DN25	SEP	SEP	
DN32	SEP	SEP	
KBV21i and KBV40i	KBV21i	1	SEP
	KBV40i	1	SEP
DN40 - DN50	1	SEP	
DN65	1	SEP	

- i) The products have been specifically designed for use on steam, compressed air, water and other industrial fluids that are in Group 2 of the above mentioned Pressure Equipment Directive. The products' use on other fluids may be possible but, if this is contemplated, Spirax Sarco should be contacted to confirm the suitability of the product for the application being considered.
- ii) Check material suitability, pressure and temperature and their maximum and minimum values. If the maximum operating limits of the product are lower than those of the system in which it is being fitted, or if malfunction of the product could result in a dangerous overpressure or overtemperature occurrence, ensure a safety device is included in the system to prevent such over-limit situations.
- iii) Determine the correct installation situation and direction of fluid flow.
- iv) Spirax Sarco products are not intended to withstand external stresses that may be induced by any system to which they are fitted. It is the responsibility of the installer to consider these stresses and take adequate precautions to minimise them.
- v) Remove protection covers from all connections and protective film from all name-plates, where appropriate, before installation on steam or other high temperature applications.

1.2 Access

Ensure safe access and if necessary a safe working platform (suitably guarded) before attempting to work on the product. Arrange suitable lifting gear if required.

1.3 Lighting

Ensure adequate lighting, particularly where detailed or intricate work is required.

1.4 Hazardous liquids or gases in the pipeline

Consider what is in the pipeline or what may have been in the pipeline at some previous time. Consider: flammable materials, substances hazardous to health, extremes of temperature.

1.5 Hazardous environment around the product

Consider: explosion risk areas, lack of oxygen (e.g. tanks, pits), dangerous gases, extremes of temperature, hot surfaces, fire hazard (e.g. during welding), excessive noise, moving machinery.

1.6 The system

Consider the effect on the complete system of the work proposed. Will any proposed action (e.g. closing isolation valves, electrical isolation) put any other part of the system or any personnel at risk?

Dangers might include isolation of vents or protective devices or the rendering ineffective of controls or alarms. Ensure isolation valves are turned on and off in a gradual way to avoid system shocks.

1.7 Pressure systems

Ensure that any pressure is isolated and safely vented to atmospheric pressure. Consider double isolation (double block and bleed) and the locking or labelling of closed valves. Do not assume that the system has depressurised even when the pressure gauge indicates zero.

1.8 Temperature

Allow time for temperature to normalise after isolation to avoid danger of burns.

1.9 Tools and consumables

Before starting work ensure that you have suitable tools and / or consumables available. Use only genuine Spirax Sarco replacement parts.

1.10 Protective clothing

Consider whether you and/or others in the vicinity require any protective clothing to protect against the hazards of, for example, chemicals, high / low temperature, radiation, noise, falling objects, and dangers to eyes and face.

1.11 Permits to work

All work must be carried out or be supervised by a suitably competent person. Installation and operating personnel should be trained in the correct use of the product according to the Installation and Maintenance Instructions.

Where a formal 'permit to work' system is in force it must be complied with. Where there is no such system, it is recommended that a responsible person should know what work is going on and, where necessary, arrange to have an assistant whose primary responsibility is safety.

Post 'warning notices' if necessary.

1.12 Handling

Manual handling of large and /or heavy products may present a risk of injury. Lifting, pushing, pulling, carrying or supporting a load by bodily force can cause injury particularly to the back. You are advised to assess the risks taking into account the task, the individual, the load and the working environment and use the appropriate handling method depending on the circumstances of the work being done.

1.13 Residual hazards

In normal use the external surface of the product may be very hot. If used at the maximum permitted operating conditions the surface temperature of these products may reach temperatures of 260 °C (500 °F).

These products are not self-draining. Take due care when dismantling or removing them from an installation (refer to 'Maintenance instructions').

1.14 Freezing

Provision must be made to protect products which are not self-draining against frost damage in environments where they may be exposed to temperatures below freezing point.

1.15 Safety information - Product specific

Hydraulic locking

Ball valves are prone to lock-up when used on certain heating / cooling applications where both steam and liquid will pass through the valve. This is caused by liquid trapped in the ball during closure being heated to create a high hydraulic pressure inside the ball cavity. To prevent this, during manufacture, a minute hole is drilled in the ball, so, that in the closed position, any excess pressure will be relieved. Spirax Sarco ball valves for these applications are clearly marked to allow the valve to be correctly installed, such that, when closed, the hole is facing the steam source.

1.16 Disposal

Unless otherwise stated in the Installation and Maintenance Instructions, this product is recyclable and no ecological hazard is anticipated with its disposal providing due care is taken.

1.17 Returning products

Customers and stockists are reminded that under EC Health, Safety and Environment Law, when returning products to Spirax Sarco they must provide information on any hazards and the precautions to be taken due to contamination residues or mechanical damage which may present a health, safety or environmental risk. This information must be provided in writing including Health and Safety data sheets relating to any substances identified as hazardous or potentially hazardous.

2. General product information

2.1 General description

The key operated boiler blowdown valve consists of a carbon steel reduced bore ball valve with carbon reinforced PTFE seats and a key operated mechanism in stainless steel. Two types of key are sold as optional extras and are available as follows:

- **Standard length key.**
- **Extended length 'T' bar type key** for use where access to the valve is limited.

To ensure compliance with boiler regulations the key cannot be removed when the valve is open.

Note: The standard length key and extended length 'T' bar type key are sold separately. It is recommended that an extended length 'T' bar type key is purchased for valve sizes DN50 and DN65.

Product availability

Valve type	Valve size	Optional extras
KBV21i and KBV40i	DN25	The following are available as optional extras for all valve sizes: Standard length key * or Extended length 'T' bar type key *
	DN32	
	DN40	
	DN50	
	DN65	

* **Please note:** A standard length key fits valve sizes DN25 to DN50. An extended length 'T' bar type key is required for the DN65.

Standards

These products comply with the requirements of the European Pressure Equipment Directive 97 / 23 / EC and carries the  mark when so required.

ISO mounting in accordance with ISO 5211.

Antistatic device complying with ISO 7121 and BS 5351.

Certification

These products are available with certification to EN 10204 3.1.

Note: All certification / inspection requirements must be stated at the time of order placement.

Note:

For additional product data see the following Technical Information Sheet: TI-P405-47.

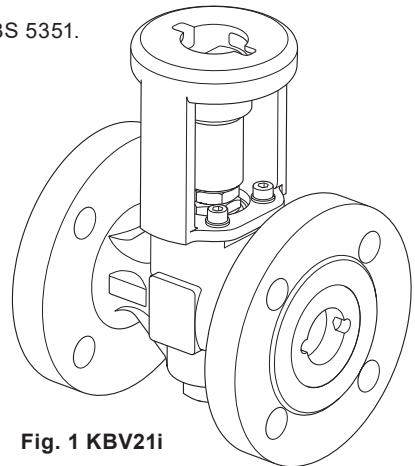

Fig. 1 KBV21i

2.2 Sizes and pipe connections

DN25, DN32, DN40, DN50 and DN65

Flanged:

- PN40 (F4), PN40 (BS) or
- ASME B 16.5 Class 300.

Available flange options:

Flange	Face-to-face	Flange thickness
PN40 (F4)	DIN 3002 F4	EN 1092 Part 1
PN40 (BS)	BS 2080	EN 1092 Part 1
ASME 300	ASME B 16.10	ASME B 16.5

2.3 KBV21i - Pressure / temperature limits

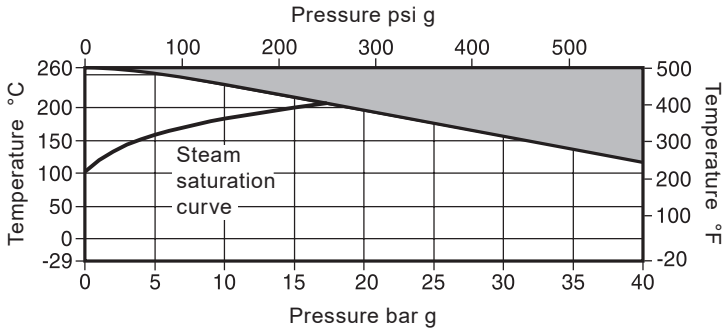

The product **must not** be used in this region.

Body design conditions		PN40
PMA	Maximum allowable pressure	40 bar g @ 120 °C (580 bar g @ 248 °F)
TMA	Maximum allowable temperature	260 °C @ 0 bar g (500 °F @ 0 psi g)
Minimum allowable temperature		-29 °C (-20 °F)
PMO	Maximum operating pressure for saturated steam service	17.25 bar g @ 208 °C (250 psi g at 406 °F)
TMO	Maximum operating temperature	260 °C @ 0 bar g (500 °F @ 0 psi g)
Minimum operating temperature		-29 °C (-20 °F)
Note: For lower operating temperatures consult Spirax Sarco		
ΔPMX	Maximum differential pressure is limited to the PMO	
Designed for a maximum cold hydraulic test pressure of:		60 bar g (870 psi g)

2.4 KBV40i - Pressure / temperature limits

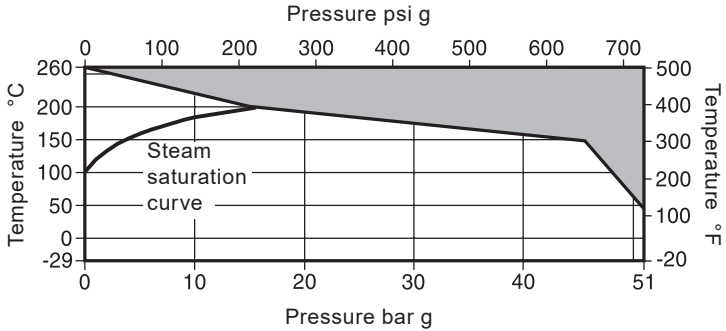

The product **must not** be used in this region.

Body design conditions		ASME 300
PMA	Maximum allowable pressure	51 bar g @ 38 °C (739 bar g @ 100 °F)
TMA	Maximum allowable temperature	260 °C @ 0 bar g (500 °F @ 0 psi g)
	Minimum allowable temperature	-29 °C (-20 °F)
PMO	Maximum operating pressure for saturated steam service	17.25 bar g @ 208 °C (250 psi g at 406 °F)
TMO	Maximum operating temperature	260 °C @ 0 bar g (500 °F @ 0 psi g)
	Minimum operating temperature	-29 °C (-20 °F)
Note: For lower operating temperatures consult Spirax Sarco		
ΔPMX Maximum differential pressure is limited to the PMO		
Designed for a maximum cold hydraulic test pressure of:		76.5 bar g (1 109 psi g)

3. Installation

Note: Before actioning any installation read the 'Safety information' in Section 1.

Although the valve has great structural integrity, severe misalignment and/or the pulling effect of incorrect pipe length will have a detrimental effect on the valve and must be avoided. Particular attention should be paid to correct pipe alignment such that the inlet pipework and valve are all on the same axis.

Wherever practicable, valves should be installed where there is adequate space available so that they can be conveniently operated and maintained.

Before installing a valve, check to ensure that size, pressure rating, materials of construction, end connections, etc. are suitable for the service conditions of the particular application. Care must be taken to ensure that all dirt which may have accumulated in the valve during storage is removed before installation, maintain cleanliness during installation since the introduction of dirt can result in damage to the valve seats and operating mechanism. To minimise the danger of abrasive particles damaging the seats, pipeline strainers should be fitted upstream of the valves.

Install the valve with the lever housing uppermost. The preferred position is with the stem vertical.

4. Commissioning

After installation or maintenance ensure that the system is fully functioning. Carry out tests on any alarms or protective devices.

5. Operation

The valve is operated with either a standard length key or extended length 'T' bar type key; both keys are supplied with a key securing nut and spring washer.

When the key orientation is at 90° to the valve body and pipework, the valve is in the closed position.

6. Maintenance

Note: Before actioning any maintenance programme observe the 'Safety information' in Section 1.

6.1 Maintenance

As with all mechanical devices, regular maintenance is the most efficient means of ensuring continued operational efficiency. Regular scheduled inspection of all valves is essential especially on valves which are operated only occasionally.

6.2 General maintenance

Remove the complete flanged valve from the pipeline. The complete body assembly can then be removed and new parts fitted.

Please note: A special tool, that is only available from Spirax Sarco, is required in order to remove the insert (2) - See Section 7, Available spares. When the seats have been replaced and the valve has been reassembled it is recommended that the following tests are conducted before commissioning back into service:

- Cold hydraulic test to the KBV21i body at 60 bar g (870 psi g), and the KBV40i body at 76.5 bar g (1 109 psi g).
- Seat leakage test using compressed air at 7 bar g.

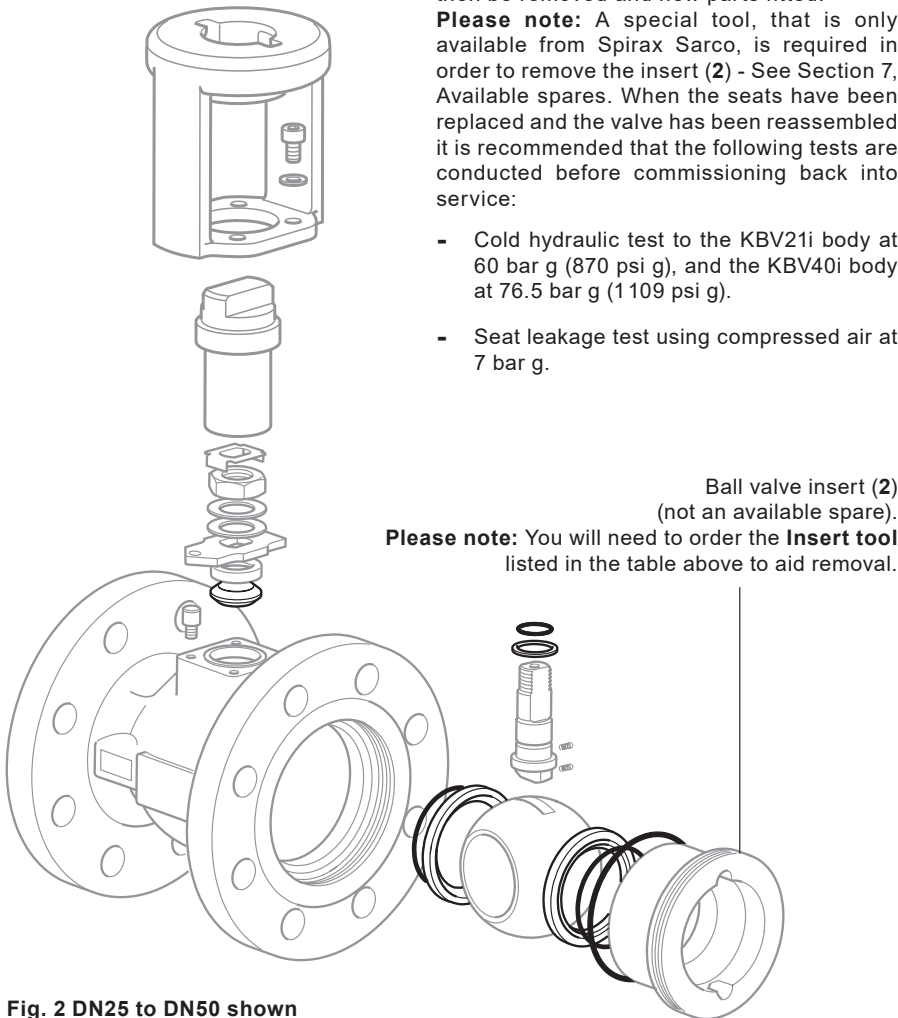

Fig. 2 DN25 to DN50 shown

6.3 How to replace the seats (5):

- Remove the key, the key housing and the body as described in Section 6.2.
- With the body removed, remove the seats (5) and 'O' ring (6).
- Fit new seats (5) pushing them into the body chamber.
- Insert a new 'O' ring (6) replace the ball valve insert (2) and tighten to the recommended torque - See Table 1.

6.4 How to replace the stem seals (9 and 10):

- Remove the body as described in Section 6.2.
- Remove the nut (15).
- Replace the stem seals (9 and 10).
- Insert a new 'O' ring (6) replace the ball valve insert (2) and tighten to the recommended torque - See Table 1.

6.5 Reassembly

Reassemble in reverse order to instructions given above. The stem nut (15) and the ball valve insert (2) should be tightened to the recommended torques shown in Table 1. Ensure that the flow direction arrow on top of the key housing corresponds with the arrow direction on the valve body.

Table 1 Recommended tightening torques

Item no.	Part	Size	N m	lbf ft
2	Insert	DN25 and DN32	108 - 135	80 - 100
		DN40	135 - 160	100 - 120
		DN50	215 - 245	160 - 180
		DN65	245 - 270	180 - 200
15	Nut	DN25	17.5 - 20.3	13 - 15
		DN32, DN40, DN50 and DN65	34 - 40	25 - 30
Key securing nut (not shown)		DN25	17.5 - 20.3	13 - 15
		DN32, DN40, DN50 and DN65	34 - 40	25 - 30

6.6 Testing:

- Ensure that the stem can rotate freely, without undue friction.
- Carry out seat leakage and body hydraulic testing as appropriate:

Seat leakage test at	6 bar g (87 psi g) (air under water)
Cold hydraulic test at	78 bar g (1 131 psi g) (Class 300)

6.7 Assembly:

- Refit the key assembly ensuring that the valve is fully closed before attempting to locate the drive adapter.

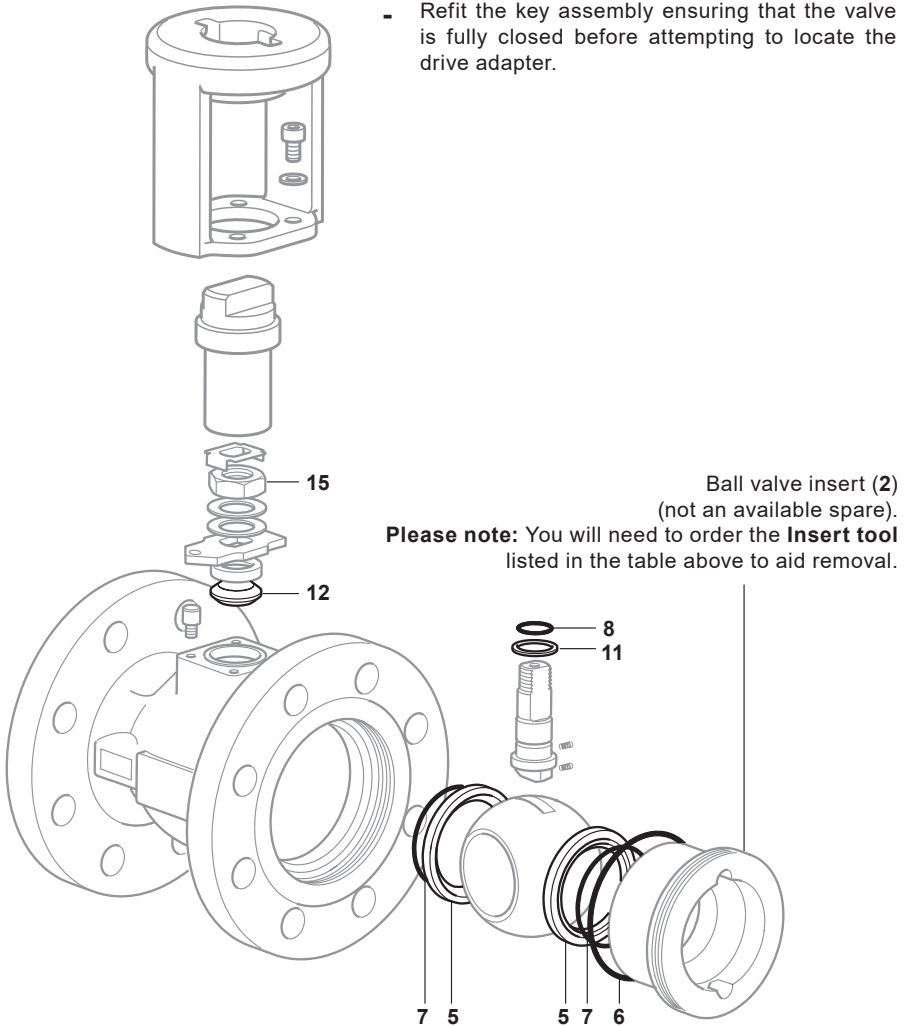

Fig. 3 DN25 to DN50 shown

7. Spare parts

7.1 DN25 to DN50 Spare parts

The spare parts available are shown in solid outline. Parts drawn in a grey line are not supplied as spares.

Available spares

Seats, insert 'O' ring and stem seals	5, 6, 9, 10
Insert tool - Required to aid the removal of the ball valve insert (2)	Not shown

Please note: Spare parts are common for both the KBV21i and KBV40i.

Caution: The ball must be installed with the vent hole on the upstream side of the valve.

How to order spares

Always order spares by using the description given in the column headed 'Available spares' and state the size and type of ball valve.

Example: 1 set of seats, insert 'O' ring and stem seals for a Spirax Sarco DN50 KBV21i boiler blowdown valve.

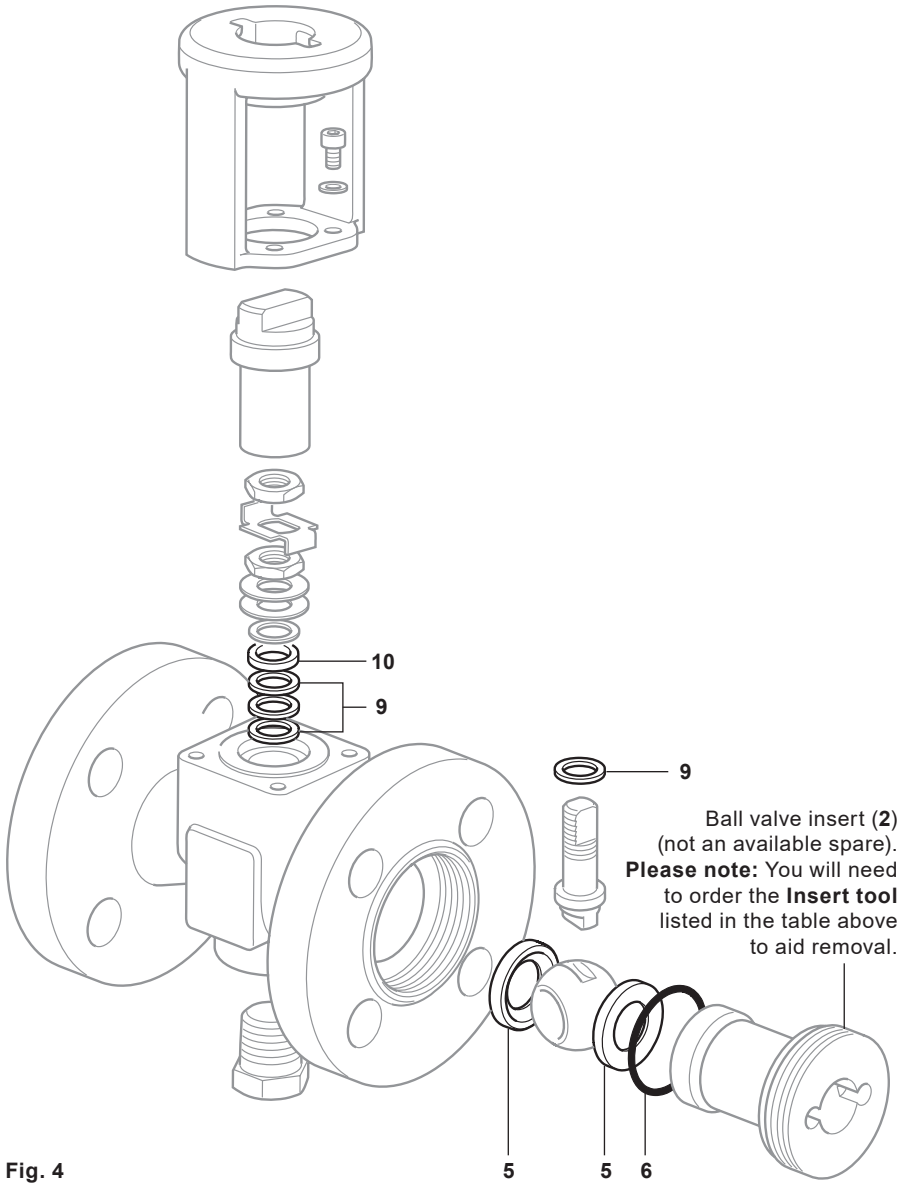

Fig. 4

7.2 DN65 Spare parts

The spare parts available are shown in solid outline. Parts drawn in a grey line are not supplied as spares.

Available spares

Seats, insert 'O' ring, seat 'O' ring, stem 'O' ring, lower stem seals and upper stem packing	5, 6, 7, 8, 11, 12
Insert tool - Required to aid the removal of the ball valve insert (2)	Not shown

Please note: Spare parts are common for both the KBV21i and KBV40i.

Caution: The ball must be installed with the vent hole on the upstream side of the valve.

How to order spares

Always order spares by using the description given in the column headed 'Available spares' and state the size and type of ball valve.

Example: 1 set of seats, insert 'O' ring, seat 'O' ring, stem 'O' ring, lower stem seals and upper stem packing for a Spirax Sarco DN50 KBV40i boiler lowdown valve.

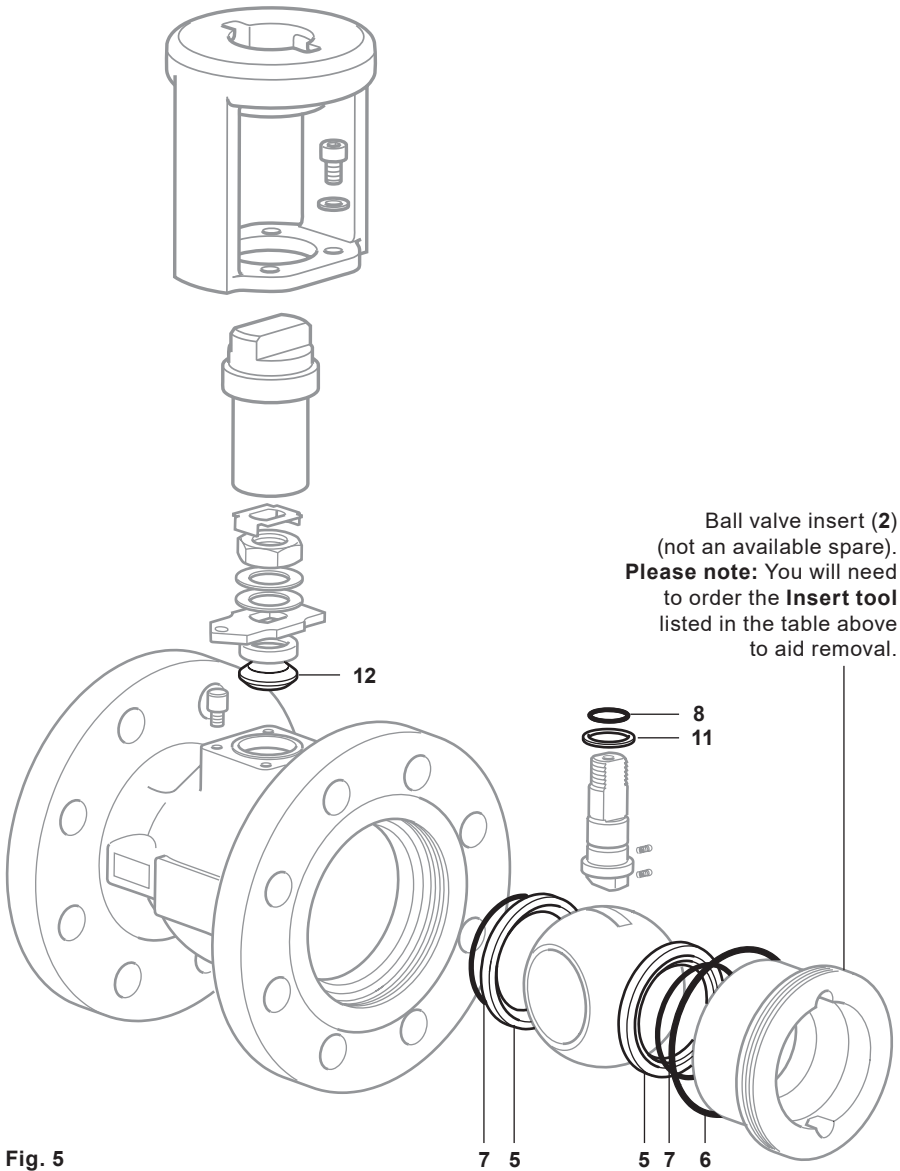

Fig. 5

