

ILVA

Flowmetering System

Installation and Maintenance Instructions

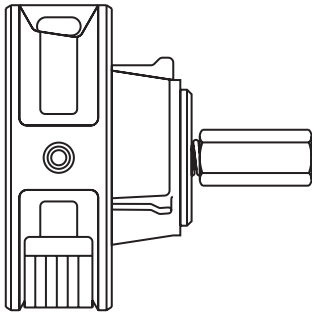

1. Safety information
2. General system information
3. General product information
4. Mechanical installation of ILVA pipeline unit
5. Impulse lines
6. Initial start-up
7. Maintenance
8. Spare parts
9. Fault finding

1. Safety information

Safe operation of these products can only be guaranteed if they are properly installed, commissioned, used and maintained by qualified personnel (see Section 1.11) in compliance with the operating instructions. General installation and safety instructions for pipeline and plant construction, as well as the proper use of tools and safety equipment must also be complied with.

1.1 Intended use

Referring to the Installation and Maintenance Instructions, name-plate and Technical Information Sheet, check that the product is suitable for the intended use/application.

The products listed below comply with the requirements of the Pressure Equipment Directive (PED) and carry the  mark when so required. The products fall within the following Pressure Equipment Directive categories:

	Product	Group 1 Gases	Group 2 Gases	Group 1 Liquids	Group 2 Liquids
ILVA pipeline unit	DN50 and DN80	2	1	-	SEP
	DN100 and DN150	3	3	-	SEP
	DN200, DN250 and DN300	3	3	-	1

- i) The products have been specifically designed for use on steam, air or condensate which are in Group 2 of the above mentioned Pressure Equipment Directive. It can also be used on propane or methane gases which are in Group 1 of the above mentioned Pressure Equipment Directive. The products' use on other fluids may be possible but, if this is contemplated, Spirax Sarco should be contacted to confirm the suitability of the product for the application being considered.
- ii) Check material suitability, pressure and temperature and their maximum and minimum values. If the maximum operating limits of the product are lower than those of the system in which it is being fitted, or if malfunction of the product could result in a dangerous overpressure or overtemperature occurrence, ensure a safety device is included in the system to prevent such over-limit situations.
- iii) Determine the correct installation situation and direction of fluid flow.
- iv) Spirax Sarco products are not intended to withstand external stresses that may be induced by any system to which they are fitted. It is the responsibility of the installer to consider these stresses and take adequate precautions to minimise them.
- v) Remove protection covers from all connections and protective film from all name-plates, where appropriate, before installation on steam or other high temperature applications.

1.2 Access

Ensure safe access and if necessary a safe working platform (suitably guarded) before attempting to work on the product. Arrange suitable lifting gear if required.

1.3 Lighting

Ensure adequate lighting, particularly where detailed or intricate work is required.

1.4 Hazardous liquids or gases in the pipeline

Consider what is in the pipeline or what may have been in the pipeline at some previous time. Consider: flammable materials, substances hazardous to health, extremes of temperature.

1.5 Hazardous environment around the product

Consider: explosion risk areas, lack of oxygen (e.g. tanks, pits), dangerous gases, extremes of temperature, hot surfaces, fire hazard (e.g. during welding), excessive noise, moving machinery.

1.6 The system

Consider the effect on the complete system of the work proposed. Will any proposed action (e.g. closing isolation valves, electrical isolation) put any other part of the system or any personnel at risk?

Dangers might include isolation of vents or protective devices or the rendering ineffective of controls or alarms. Ensure isolation valves are turned on and off in a gradual way to avoid system shocks.

1.7 Pressure systems

Ensure that any pressure is isolated and safely vented to atmospheric pressure.

Consider double isolation (double block and bleed) and the locking or labelling of closed valves. Do not assume that the system has depressurised even when the pressure gauge indicates zero.

1.8 Temperature

Allow time for temperature to normalise after isolation to avoid danger of burns.

1.9 Tools and consumables

Before starting work ensure that you have suitable tools and/or consumables available. Use only genuine Spirax Sarco replacement parts.

1.10 Protective clothing

Consider whether you and/or others in the vicinity require any protective clothing to protect against the hazards of, for example, chemicals, high/low temperature, radiation, noise, falling objects, and dangers to eyes and face.

1.11 Permits to work

All work must be carried out or be supervised by a suitably competent person.

Installation and operating personnel should be trained in the correct use of the product according to the Installation and Maintenance Instructions.

Where a formal 'permit to work' system is in force it must be complied with. Where there is no such system, it is recommended that a responsible person should know what work is going on and, where necessary, arrange to have an assistant whose primary responsibility is safety.

Post 'warning notices' if necessary.

1.12 Handling

Manual handling of large and/or heavy products may present a risk of injury. Lifting, pushing, pulling, carrying or supporting a load by bodily force can cause injury particularly to the back. You are advised to assess the risks taking into account the task, the individual, the load and the working environment and use the appropriate handling method depending on the circumstances of the work being done.

Safe lifting of Spirax Sarco products

Please note that the Spirax Sarco DN250 and DN300 ILVA are supplied with the provision for eyebolts to BS 4278 (to be supplied by others), with tapped holes located in the body, which may be used for lifting purposes at the sole risk and responsibility of the purchaser.

The purchaser is responsible for the use of the correct eyebolt or shackle combination and is, in whole, responsible for all lifting operations and operator competency at their location.

Spirax Sarco will accept no responsibility for loss or damage real or imagined, caused by incorrect or inappropriate lifting of our products.

Spirax Sarco will also carry out in conjunction with a third party, a test on a sample of each product so provided and make available a copy of the test procedure and test certificate on request.

Furthermore and without obligation Spirax Sarco will attach to each product provided with such holes, threaded or otherwise, a disclaimer affixed to the product explaining the purchaser's duty under the LOLER regulations for safe off-loading and lifting of the product at their premises.

1.13 Residual hazards

In normal use the external surface of the product may be very hot. If used at the maximum permitted operating conditions the surface temperature of some products may reach temperatures of 450 °C (842 °F).

Many products are not self-draining. Take due care when dismantling or removing the product from an installation (refer to 'Maintenance instructions').

1.14 Freezing

Provision must be made to protect products which are not self-draining against frost damage in environments where they may be exposed to temperatures below freezing point.

1.15 Disposal

Unless otherwise stated in the Installation and Maintenance Instructions, this product is recyclable and no ecological hazard is anticipated with its disposal providing due care is taken.

1.16 Returning products

Customers and stockists are reminded that under EC Health, Safety and Environment Law, when returning products to Spirax Sarco they must provide information on any hazards and the precautions to be taken due to contamination residues or mechanical damage which may present a health, safety or environmental risk. This information must be provided in writing including Health and Safety data sheets relating to any substances identified as hazardous or potentially hazardous.

2. General system information

2.1 Introduction

This booklet gives full details of the recommended procedures for the installation and maintenance of the Spirax Sarco ILVA flowmeter. Abbreviated details of how to install the M610 or Multi-variable transmitter assembly (MVT), EL2600 pressure transmitter and EL2271 temperature transmitter are also given. (Full details are supplied with the equipment).

Initial start-up procedures as well as fault finding guidelines are also included.

2.2 The Spirax Sarco ILVA flowmetering system consists of three major elements:

2.2.1 The ILVA pipeline unit

This is installed in the line where the flow is to be measured. Using impulse pipework, this is connected to:

2.2.2 The M610 or MVT assemblies

The M610 measures the differential pressure across the ILVA pipeline unit and converts it to a 4-20 mA output signal for onward transmission to other equipment.

The MVT measures the differential pressure and static pressure across the ILVA pipeline unit and converts this to a 4-20 mA output signal proportional to mass flow.

2.2.3 Readout equipment

This can be either an M850 flow computer (steam) or an M750 display unit for non density compensated applications on steam, liquids or gases. Note that all these items of equipment are used to linearise the output signal from the ILVA pipeline unit.

Caution: MVT steam mass flow transmitters are uniquely configured at the factory to work with a single, specific ILVA flowmeter. For correct operation the configured transmitter must always be installed with its allocated flowmeter. Labels on the packaging give the serial numbers of the matched products.

2.3 Additional equipment (not required for the compact stem versions)

2.3.1 F50C isolation valves which are installed close to the ILVA unit to provide primary isolation.

2.3.2 EL2600 pressure transmitter which is connected to the impulse lines using a 'T' piece in the high pressure (upstream) impulse line. This gives a 4-20 mA output signal proportional to line pressure and is used where density compensation based on pressure is required.

2.3.3 EL2271 temperature transmitter which is installed directly in the pipework upstream of the ILVA pipeline unit. This gives a 4-20 mA signal proportional to line temperature and is used where density compensation based on temperature is required.

Standard installation

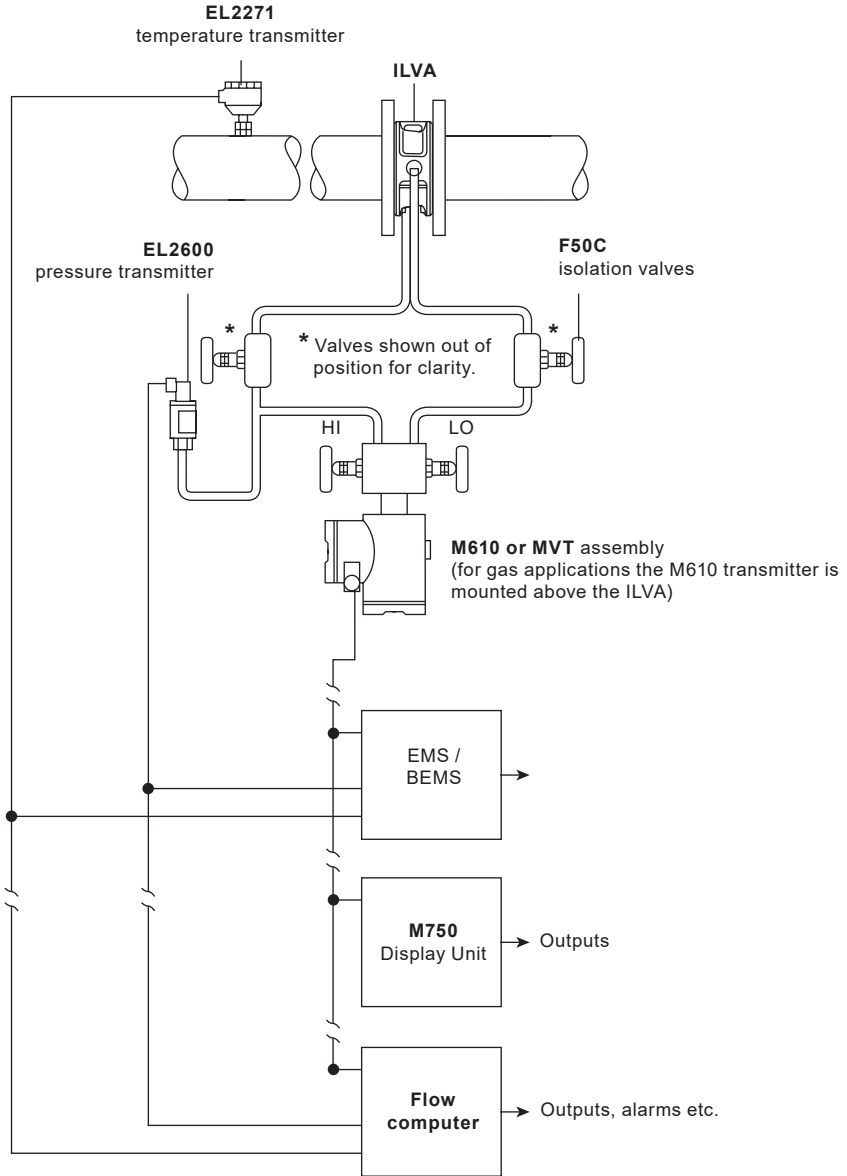

Fig. 1 (Schematic only) See Figure 15 for details

3. General product information

3.1 Description

The ILVA flowmeter operates on the spring loaded variable area principle and produces a differential pressure proportional to the instantaneous rate of flow. It can be used with most industrial fluids, gases and both saturated and superheated steam.

3.2 Sizes and pipe connections

ILVA: DN50, DN80, DN100, DN150, DN200, DN250 and DN300.

Suitable for fitting between the following flanges:

EN 1092 PN16, PN25, and PN40.

BS 10 Table H.

ASME B 16.5 class 150, 300 and 600.

Japanese Industrial Standard JIS 20.

Korean Standard KS 20.

3.3 Materials

Body	Austenitic stainless steel S316
Internals	431 S29/S303/S304/S316
Spring	Inconel X750 or equivalent

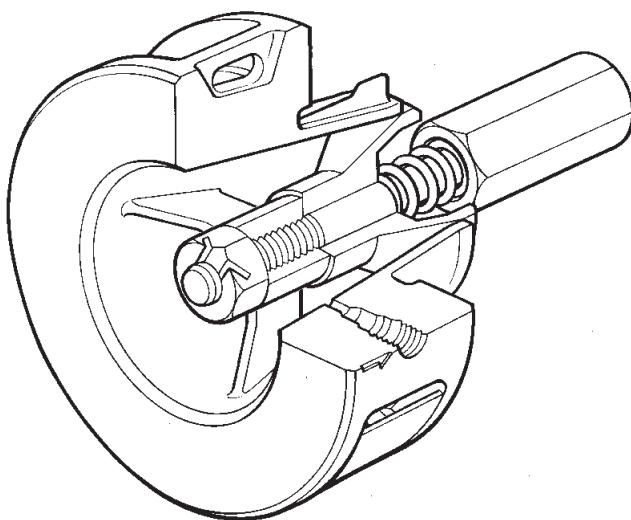
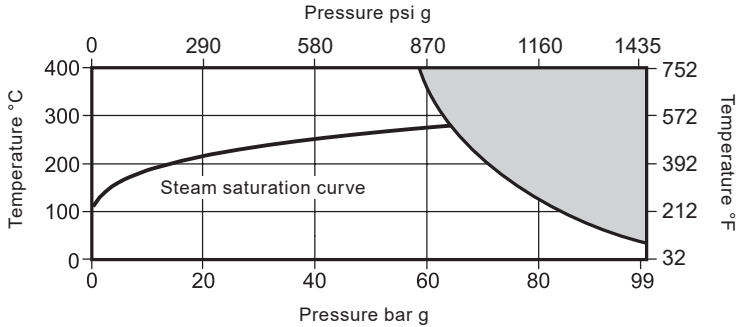



Fig. 2 ILVA (DN200 shown)

3.4 Pressure/temperature limits



 The product **must not** be used in this region.

Body design conditions		ASME 600	
PMA	Maximum allowable pressure	99.3 bar g @ 38 °C	(1440 psi g @ 100 °C)
TMA	Maximum allowable temperature	400 °C @ 58.9 bar g	(752 °F @ 854 psi g)
	Minimum allowable temperature	-29 °C	(-20 °F)
PMO	Maximum operating pressure	99.3 bar g @ 38 °C	(1440 psi g @ 100 °C)
	Minimum operating pressure	0.6 bar g	(8.7 psi g)
TMO	Maximum operating temperature	400 °C @ 58.9 bar g	(752 °F @ 854 psi g)
	Minimum operating temperature	-29 °C	(-20 °F)
Note: For lower operating temperatures consult Spirax Sarco.			
	Maximum viscosity	30 centipoise	
ΔPMX	Maximum differential pressure	498 m bar	
Designed for a maximum cold hydraulic test pressure of:		149 bar g	(2162 psi g)

3.5 Pressure drop

The pressure drop across the ILVA pipeline unit is nominally 498 m bar (200 ins water gauge) at maximum rated flow.

3.6 Dimensions / weights (approximate) in mm and kg

ILVA pipeline unit DN50 - DN300

Size	A	B	C	D	E	F	Weight
DN50	35	163	140	103	17.5		2.0
DN80	45	178	150	138	22.5		3.9
DN100	61.5	103	205	162	37.5		8.3
DN150	75	134	300	218	37.5		14.2
DN200	85	161	360	273	42.5		23.6
DN250	104	204	444	330	34.5	35	41.5
DN300	120	250	530	385	42.5	35	67.0

Note:- Pressure tapplings are threaded 1/4" NPT.

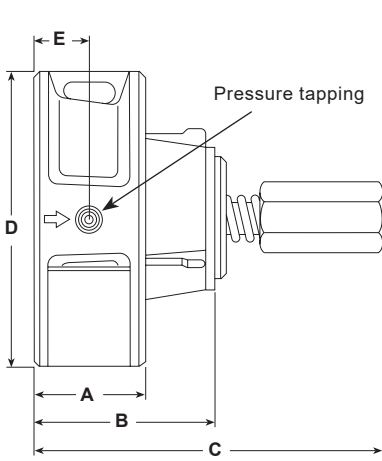

Fig. 3 ILVA DN50 – DN200

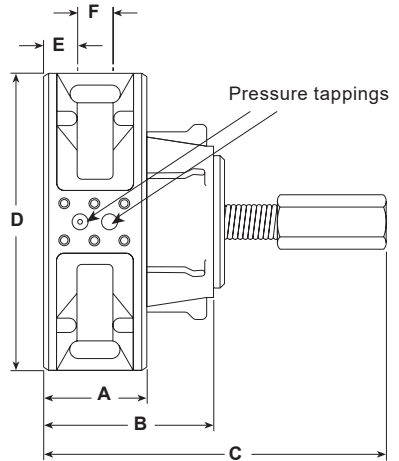

Fig. 4 ILVA DN250 – DN300

4. Mechanical installation of ILVA pipeline unit

Caution: In order for the ILVA flowmeter to meet its specified accuracy and performance, it is essential that the following guidelines for installation are followed carefully. For steam flow measurement, good basic steam engineering practices should be followed as detailed in Section 6.1.

4.1 Orientation

The ILVA should be installed in a horizontal line. As it has been calibrated in a horizontal attitude, mounting it in a vertical line (flow downwards) may introduce a small flow measurement error. If installation with flow vertically downwards is unavoidable, please consult Spirax Sarco for advice. The flowmeter should not be installed with flow vertically upwards (see Figure 5).

The pressure tappings should be horizontal and located as shown in Figure 6.

The ILVA is clearly marked with a direction of flow arrow.

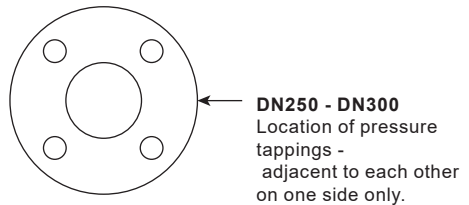
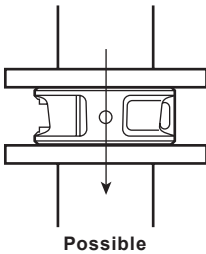
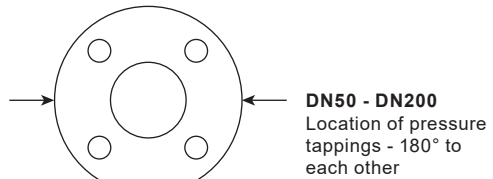
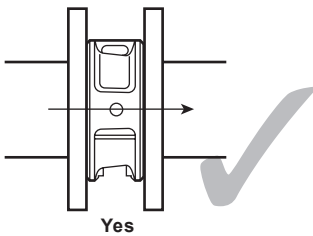

Fig. 6

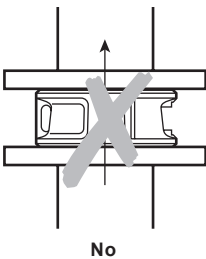

Fig. 5

4.2 Upstream/downstream pipework

The ILVA flowmeter should be installed in pipework manufactured to BS 1600 or ASME B 36.10 Schedule 40, which corresponds to the following pipeline internal diameters.

Nominal diameter	Nominal internal diameter
50 mm	52 mm
80 mm	77 mm
100 mm	102 mm
150 mm	154 mm
200 mm	202 mm
250 mm	254 mm
300 mm	303 mm

For different pipe standards/schedules, if the flowmeter is being operated at the extreme of its published maximum range, downstream spool pieces manufactured from BS 1600 or ASME B 36.10 Schedule 40 should be used. If this is not possible, please contact Spirax-Sarco Ltd.

It is important that the internal upstream and downstream diameters of pipe are smooth. Ideally seamless pipes should be used and there should be no intrusive weld beads on the internal diameter. It is recommended that slip-on flanges be used to avoid any intrusive weld beads on the internal diameter of the pipe.

The ILVA normally only requires a minimum of 6 pipe diameters upstream and 3 downstream of clear straight pipe. These dimensions assume a measurement from a single 90° bend. See Figure 7.

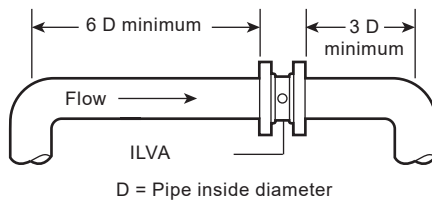

Fig. 7

If any of the following configurations are present upstream of the ILVA, then it is recommended that the minimum upstream clear pipework is doubled to 12 diameters.

- Two right angled bends in two planes.
- Pressure reducing valve.
- Partly open valve.
- Pipe diameter cross sectional area changes.

Avoid installing the ILVA flowmeter downstream of an actuated valve as rapid cycling of the valve could give rise to inaccurate results or damage the flowmeter. See Figure 8.

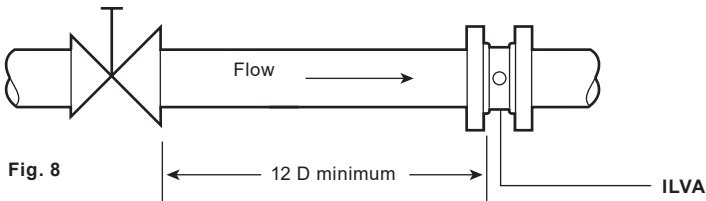
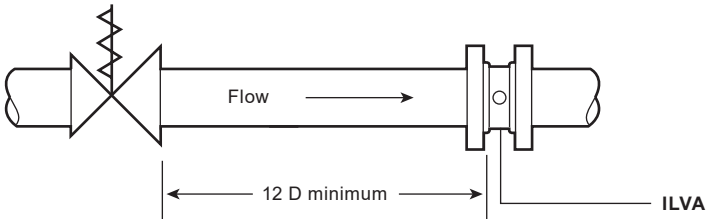
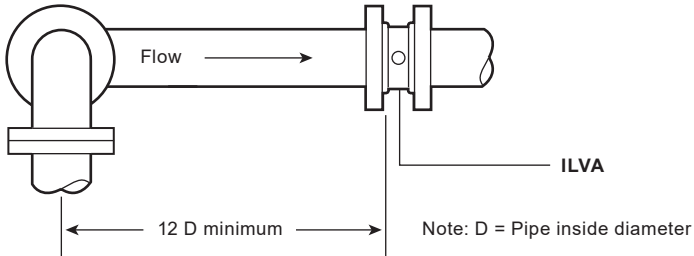

Fig. 8

We recommend that a spool piece is used to aid installation and removal (see opposite).

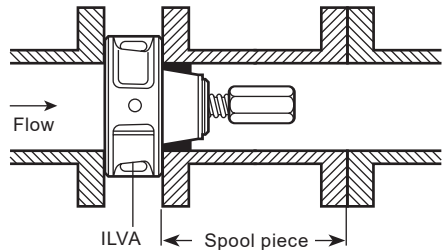
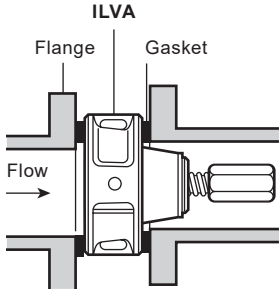

Fig. 9

4.3 Location in pipework

Bolt ring gaskets having the same internal diameter of the pipework are recommended. This will prevent possible inaccuracies being created by the gasket protruding into the pipe.



✗
Eccentricity

It is important that the ILVA is located centrally in the pipework as any eccentricity may cause inaccurate readings. The ILVA has been designed with integral centering webs which locate on the internal diameter of the pipework. In applications where large pipe schedule has been used, it is possible to remove some of the material from these webs to fit the pipework. This should be done with utmost care to prevent any contamination or damage to the flowmeter.

Note: material should be removed from all three webs equally to ensure that the flowmeter remains concentric to the pipe.

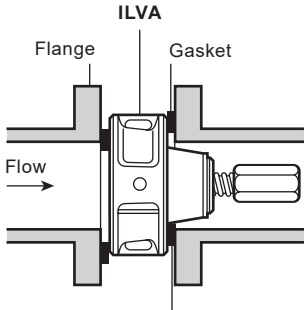

Gaskets protruding into line

✗

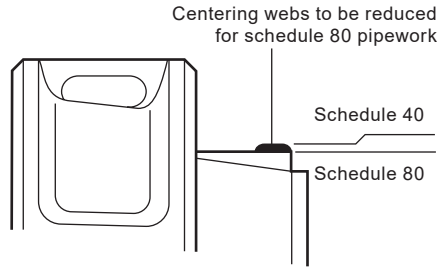

Fig. 11

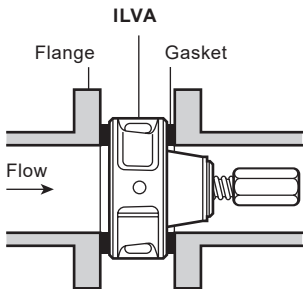

Fig. 10

✓

4.4 Pressure tappings

The ILVA has integral pressure tappings for connection to the M610/MVT transmitter assembly using impulse lines. These are threaded 1/4" NPT and are clearly marked HI (upstream) and LO (downstream). Care should be taken to ensure that these are correctly connected.

5. Impulse lines

5.1 Versions with standard impulse lines

The standard ILVA installation has two impulse lines, a high pressure side and a low pressure side. These are supplied separately from the ILVA and DP cell, by the installer.

- 5.1.1 These should be of a suitable pressure rating and be as short as possible. However, for high temperature applications they should be long enough to prevent damage to the M610 or MVT through excessive temperature (85 °C (185 °F) maximum).
- 5.1.2 Recommended minimum inside diameter is 9.5 mm (0.375").
- 5.1.3 Lines should run vertically downwards for steam and liquids applications and upwards for gases wherever possible but in no case should a gradient less than 1 in 12 be permitted.
- 5.1.4 Lines should run over the same route (preferably clipped together) to avoid temperature differentials.
- 5.1.5 Consideration should be given to allowing the impulse lines to be blown through or 'rodded' to remove excessive build-up of dirt or sludge.
- 5.1.6 If impulse lines are filled with water and may be subject to freezing, trace heating or use of antifreeze is recommended.
- 5.1.7 The orientation of the impulse lines and M610/MVT assembly depends on the service application. See Figures 13 to 17.

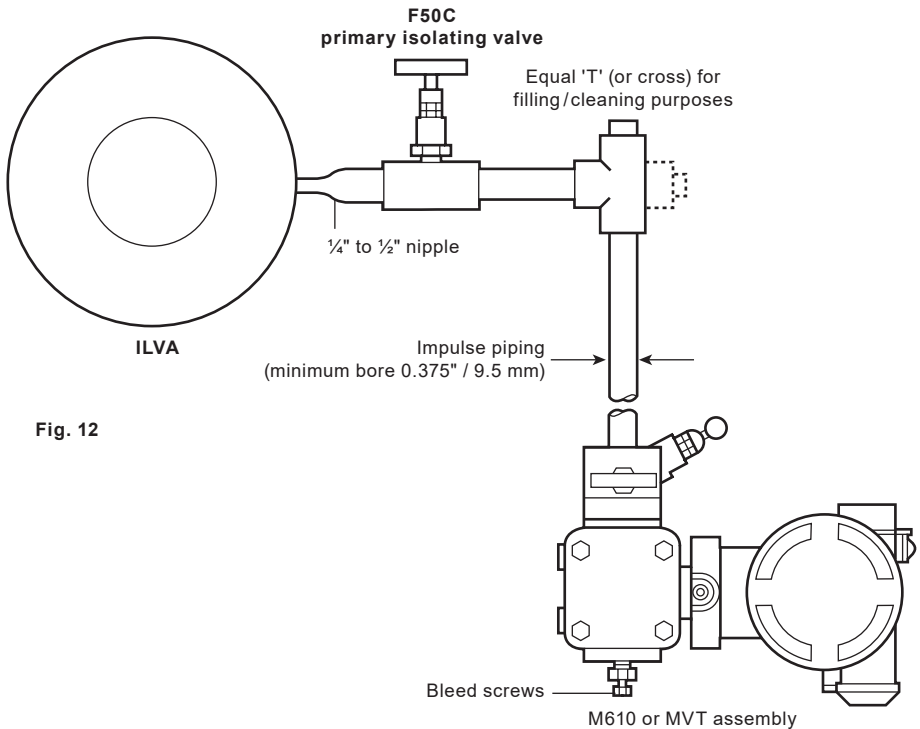

Fig. 12

Fig. 13 Liquids, vapours, steam

For liquids, vapours and steam where the ILVA is installed in a horizontal line, the M610/MVT should be mounted as shown opposite.

Note: The MVT is for saturated steam applications only.

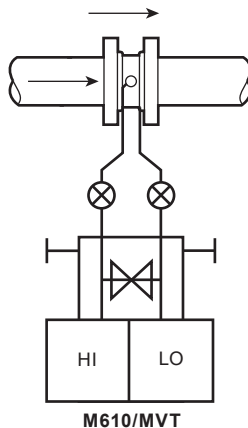

Fig. 14 Saturated Steam only

DN250 and DN300 versions with compact stem must be fitted with the stem and MVT below the ILVA.

Note: The MVT is for saturated steam applications only.

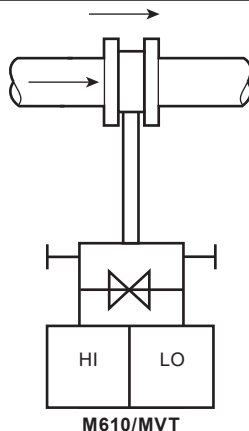

Fig. 15 Liquids, vapours, steam

If for space limitations, the configuration described in Figure 17 is not possible then the arrangement shown opposite should be used (with vented gas collecting chambers at A for liquids).

Note: The MVT is for saturated steam applications only.

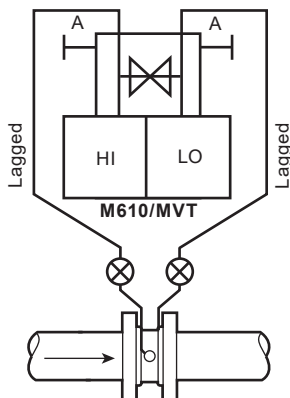

Fig. 16 Gases

For gases where the ILVA is installed in a horizontal line, the M610 should be mounted above the ILVA as shown opposite.

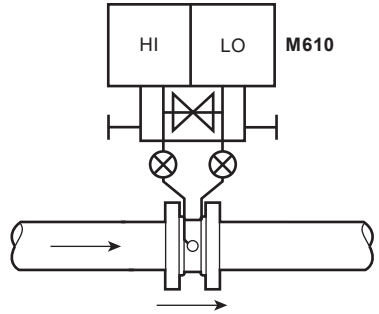
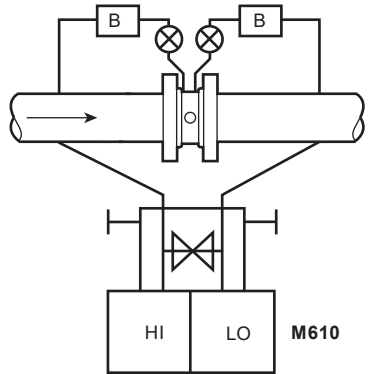

Fig. 17 Gases

If, for space limitations the configuration described in Figure 16 is not possible, then the arrangement shown opposite should be used. The condensate pots shown at B are only required if the gas is wet.



6. Initial start-up

After all mechanical and electrical work has been completed, the initial start-up procedures should be followed.

Standard installation

6.1 Steam systems, vapour systems and all applications where the impulse lines must be filled with water

- 6.1.1 Close both F50C isolation valves adjacent to the ILVA pipeline unit.
- 6.1.2 Open all the valves on the 3-way manifold on the M610/MVT assembly.
- 6.1.3 Fill both impulse lines with water (with antifreeze if required) through the equal 'T' (Figure 12).
- 6.1.4 Ensure that no air bubbles are trapped in the impulse lines by using the bleed screws on the M610/MVT.
- 6.1.5 Where an EL2600 pressure transmitter is fitted to the system, remove the pressure transmitter and fill the vertical cooling leg with water. Refit the pressure transmitter and ensure that its isolation valve is open.
- 6.1.6 Reassemble all impulse pipework (if applicable).
- 6.1.7 Close the LO valve on the 3-way manifold.
- 6.1.8 Open both F50C isolation valves. Adjust zero on M610/MVT to read 4.00 mA (see Sections 7.2 and 7.3).
- 6.1.9 Close the central equalisation valve on the 3-way manifold.
- 6.1.10 Open LO valve on the 3-way manifold.

The system is now operational.

Note: To commission the flow computer, the 'ILVA commissioning option' should be chosen on the flow computer, and coefficients 'VWXYZ' should be used.

For flow computers without the 'ILVA commissioning option', (M200 version flow computers with software version V905 - 12.00 and below), the 'ABCDE' coefficients should be used in the 'Commissioning option'.

Please refer to separate literature and the ILVA calibration pack supplied with the flowmeter.

6.2 Liquids, gases and all applications where the impulse lines are filled with the fluid/gas being metered

Note: for all applications where the working fluid is above 85 °C (185 °F), care should be taken to avoid subjecting the M610 to excessive temperatures as this could result in permanent damage. The impulse line configuration shown in Figure 17 is suitable.

- 6.2.1** Close both F50C isolation valves adjacent to the ILVA pipeline unit.
- 6.2.2** Close the LO valve on the 3-way manifold.
- 6.2.3** Open the central equalisation valve and HI valve on the 3-way manifold.
- 6.2.4** Open both the F50C isolation valves adjacent to the ILVA pipeline unit.
- 6.2.5** Slowly bleed the air/gases from the system using the bleed screws on the M610. Adjust zero on M610 to read 4.00 mA (see Section 7.2).
- 6.2.6** Close the central equalisation valve on the 3-way manifold.
- 6.2.7** Open the LO valve on the 3-way manifold.
- 6.2.8** Where an EL2600 pressure transmitter is being used for density compensation, ensure that its isolation valve is open.

The system is now operational.

Note: To commission the flow computer, the 'ILVA commissioning option' should be chosen on the flow computer, and coefficients 'VWXYZ' should be used.

For flow computers without the 'ILVA commissioning option', (M200 version flow computers with software version V905 - 12.00 and below), the 'ABCDE' coefficients should be used in the 'Commissioning option'.

Please refer to separate literature and the ILVA calibration pack supplied with the flowmeter.

7. Maintenance

There are several basic checks that should be carried out on a regular basis:

7.1 Impulse lines

We at Spirax Sarco recommend periodic cleaning of the impulse lines to prevent excessive build-up of sludge or deposits.

7.2 M610 DP transmitter

Zero and span checks on the DP transmitter should be carried out on a regular basis (ideally every 6 months). The 3-way manifold that forms part of the M610 assembly makes this easy. The procedure for checking the DP transmitter without removing it from site or shutting down the flow is as follows:

- 7.2.1** Ensure that the DP transmitter is powered up.
- 7.2.2** Close the F50C primary isolation valves adjacent to the ILVA flowmeter.
- 7.2.3** Open all the valves on the 3-way manifold. This will allow the pressure in the two impulse lines to equalise.
- 7.2.4** Using a suitable milliammeter, check that the output of the DP transmitter is 4.00 mA across terminals CK+ and CK- as shown in Figure 16. (If a flow display is being used, it should read zero.) Set the mode switch (SW1) to the 'zero' position and adjust the zero output using the output adjustment until a value of exactly 4.00 mA is achieved.
- 7.2.5** Open central equalisation valve on 3-way manifold.
- 7.2.6** Remove both bleed plug assemblies on the DP transmitter.
- 7.2.7** Close central equalisation valve on 3-way manifold.
- 7.2.8** Using a suitable precision pressure source attached to the HI pressure port of the DP transmitter as shown in Figure 24, apply a pressure corresponding to the set pressure of the unit. (For ILVA flowmeters, this is normally factory set to 498 mbar/200 inches water gauge).
- 7.2.9** Set the mode switch (SW1) to the 'span' position and adjust the span output using the output adjustment until a value of exactly 20.00 mA is achieved.
- 7.2.10** Remove pressure source, open the central equalisation valve and then refit and tighten the bleed plug assemblies.
- 7.2.11** Close the LO valve on the 3-way manifold.
- 7.2.12** Open both the F50C isolation valves adjacent to the ILVA pipeline unit.
- 7.2.13** Close the central equalisation valve on the 3-way manifold.
- 7.2.14** Open the LO valve on the 3-way manifold.
- 7.2.15** Where an EL2600 pressure transmitter is being used for density compensation, ensure that its isolation valve is open.
- 7.2.16** Remove test leads and replace all covers on the M610 transmitter.

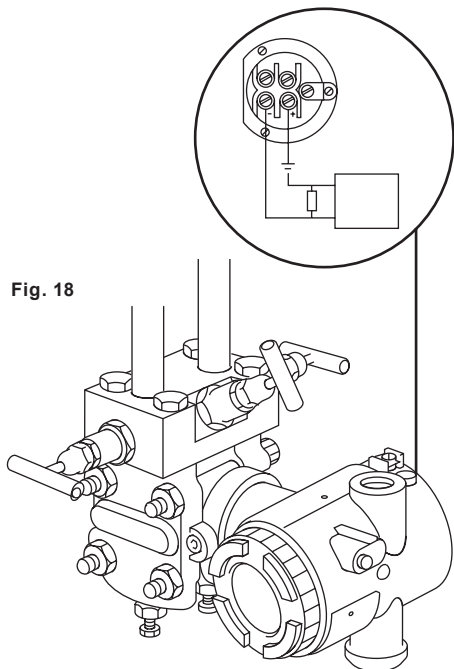

Fig. 18

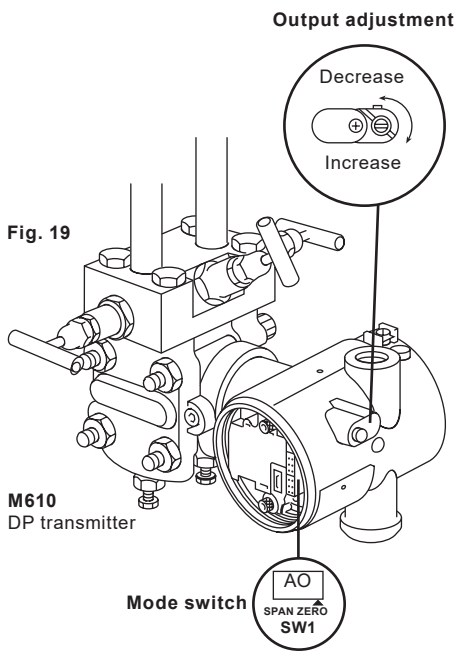
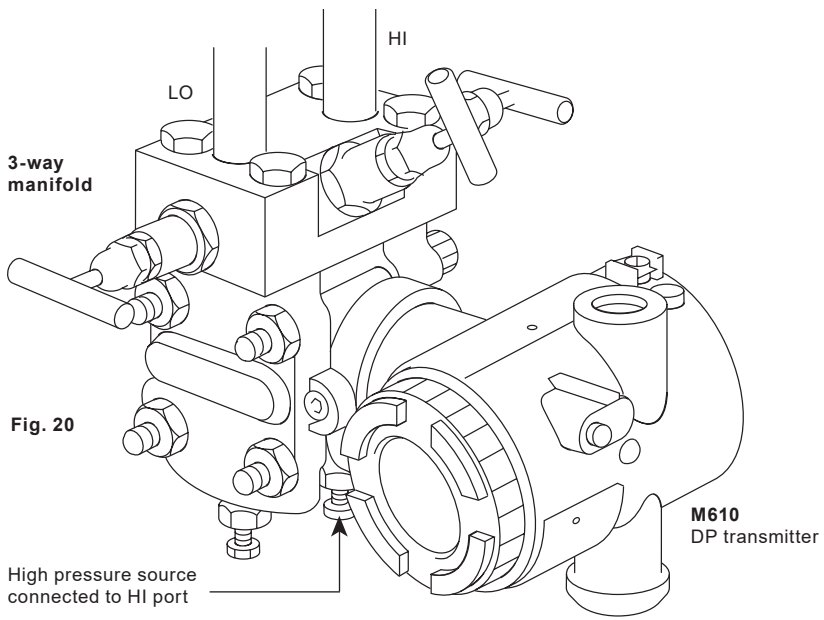

Fig. 19

M610 DP transmitter

Mode switch



3-way manifold

Fig. 20

High pressure source connected to HI port

M610 DP transmitter

7.3 Multi-variable transmitter (MVT)

See the product specific Installation and Maintenance Instructions for details.

7.4 Optional 5-way manifold

An optional 5-way manifold is available with two additional isolating valves. These can be used as impulse line/compact stem drain/blow down points. The outlet ports must be hard piped to a safe area, as line pressure will be discharged.

7.4.1 To blow down the impulse lines close the Hi, Lo and bypass valves.

7.4.2 Slowly open either of the vent isolation valves for few seconds until dirt/sludge has cleared.

7.4.3 Close the vent isolation valve and repeat the process (Section 7.5.2) on the other side.

7.4.4 Refill the impulse lines as per Section 6. For the version with compact stem allow time for the compact stem to refill with condensate before continuing.

7.4.5 Zero the M610 or MVT following instructions as per Sections 7.2 to 7.4.

7.5 ILVA pipeline unit

It is also possible to carry out some simple checks on the ILVA flowmeter on site to confirm its correct operation. To do this, it is necessary to remove the unit from the line.

Checks possible:

1. Cone free to move on shaft.
2. DP tapings clear.

7.5.1 Cone free on shaft

With the ILVA positioned vertically as shown in Figure 25, check that the cone is free to move up and down the shaft against the resistance of the spring.

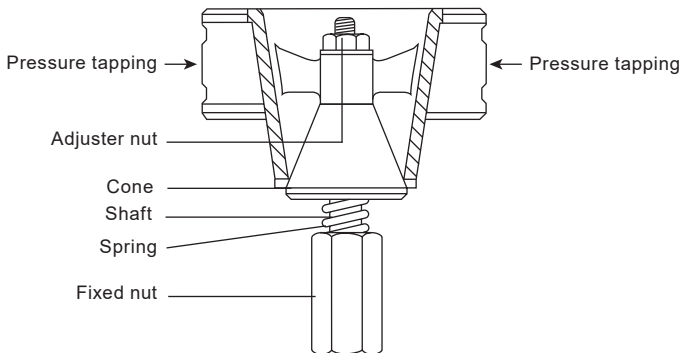

Fig. 21

8. Spare parts

Please note: There are no available spare parts for the ILVA.

9. Fault finding

Symptom	Possible cause	Action
1. With flow in line, system reads zero	Primary isolation valves adjacent to the ILVA closed	Commission system (see Section 6)
	Isolation valves on 3-way manifold closed	
	Equalisation valve on 3-way manifold open	
	M610/MVT incorrectly wired	Check wiring (see flow computer IMI)
	Impulse line(s) blocked	Clear lines and commission system (see Section 6)
2. With no flow in line, system does not read zero	Impulse lines reversed (HI to LO, LO to HI)	Rectify and commission system (see Section 6)
	ILVA unit fitted the wrong way round	
	M610/MVT out of calibration	See Section 7
	Zero drift on M610/MVT	
	Dirt / air in impulse lines	Clear lines and commission system (see Section 6)
Impulse lines blocked	Clear lines and commission system (see Section 6)	
3. System appears to read incorrectly	Any one or combination of the above causes	See relevant actions above
	Damaged / jammed ILVA pipeline unit	Remove and check (see Section 7)

