

---

---

**IF2M, IF2AM and IF2DM**  
**Monnier International Compressed Air Filters**  
Installation and Maintenance Instructions

---

---



1. Safety information
2. General product information
3. Installation and commissioning
4. Operation
5. Spare parts and maintenance

# 1. Safety information

Safe operation of these products can only be guaranteed if they are properly installed, commissioned, used and maintained by qualified personnel (see Section 1.11) in compliance with the operating instructions. General installation and safety instructions for pipeline and plant construction, as well as the proper use of tools and safety equipment must also be complied with.

## 1.1 Intended use

Referring to the Installation and Maintenance Instructions, name-plate and Technical Information Sheet, check that the product is suitable for the intended use/application. The products comply with the requirements of the European Pressure Equipment Directive 2014/68/EU and fall within the category 'SEP'.

It should be noted that products within this category are required by the Directive not to carry the  mark.

- i) The products have been specifically designed for use on compressed air, which is in Group 2 of the above mentioned Pressure Equipment Directive. The products' use on other fluids may be possible but, if this is contemplated, Spirax Sarco should be contacted to confirm the suitability of the product for the application being considered.
- ii) Check material suitability, pressure and temperature and their maximum and minimum values. If the maximum operating limits of the product are lower than those of the system in which it is being fitted, or if malfunction of the product could result in a dangerous overpressure or overtemperature occurrence, ensure a safety device is included in the system to prevent such over-limit situations.
- iii) Determine the correct installation situation and direction of fluid flow.
- iv) Spirax Sarco products are not intended to withstand external stresses that may be induced by any system to which they are fitted. It is the responsibility of the installer to consider these stresses and take adequate precautions to minimise them.
- v) Remove protection covers from all connections and protective film from all name-plates, where appropriate, before installation on steam or other high temperature applications.

## 1.2 Access

Ensure safe access and if necessary a safe working platform (suitably guarded) before attempting to work on the product. Arrange suitable lifting gear if required.

## 1.3 Lighting

Ensure adequate lighting, particularly where detailed or intricate work is required.

## 1.4 Hazardous liquids or gases in the pipeline

Consider what is in the pipeline or what may have been in the pipeline at some previous time. Consider: flammable materials, substances hazardous to health, extremes of temperature.

## 1.5 Hazardous environment around the product

Consider: explosion risk areas, lack of oxygen (e.g. tanks, pits), dangerous gases, extremes of temperature, hot surfaces, fire hazard (e.g. during welding), excessive noise, moving machinery.

## 1.6 The system

Consider the effect on the complete system of the work proposed. Will any proposed action (e.g. closing isolation valves, electrical isolation) put any other part of the system or any personnel at risk? Dangers might include isolation of vents or protective devices or the rendering ineffective of controls or alarms. Ensure isolation valves are turned on and off in a gradual way to avoid system shocks.

## 1.7 Pressure systems

Ensure that any pressure is isolated and safely vented to atmospheric pressure. Consider double isolation (double block and bleed) and the locking or labelling of closed valves. Do not assume that the system has depressurised even when the pressure gauge indicates zero.

## 1.8 Temperature

Allow time for temperature to normalise after isolation to avoid danger of burns.

## 1.9 Tools and consumables

Before starting work ensure that you have suitable tools and/or consumables available. Use only genuine Spirax Sarco replacement parts.

## 1.10 Protective clothing

Consider whether you and/or others in the vicinity require any protective clothing to protect against the hazards of, for example, chemicals, high/low temperature, radiation, noise, falling objects, and dangers to eyes and face.

## 1.11 Permits to work

All work must be carried out or be supervised by a suitably competent person.

Installation and operating personnel should be trained in the correct use of the product according to the Installation and Maintenance Instructions.

Where a formal 'permit to work' system is in force it must be complied with. Where there is no such system, it is recommended that a responsible person should know what work is going on and, where necessary, arrange to have an assistant whose primary responsibility is safety.

Post 'warning notices' if necessary.

## 1.12 Handling

Manual handling of large and/or heavy products may present a risk of injury. Lifting, pushing, pulling, carrying or supporting a load by bodily force can cause injury particularly to the back. You are advised to assess the risks taking into account the task, the individual, the load and the working environment and use the appropriate handling method depending on the circumstances of the work being done.

## 1.13 Residual hazards

In normal use the external surface of the product may be very hot. If used at the maximum permitted operating conditions the surface temperature of some products may reach temperatures of 90 °C (194 °F).

Many products are not self-draining. Take due care when dismantling or removing the product from an installation (refer to 'Maintenance instructions').

## 1.14 Freezing

Provision must be made to protect products which are not self-draining against frost damage in environments where they may be exposed to temperatures below freezing point.

## 1.15 Disposal

Unless otherwise stated in the Installation and Maintenance Instructions, this product is recyclable and no ecological hazard is anticipated with its disposal providing due care is taken.

Please visit the Spirax Sarco product compliance web pages

<https://www.spiraxsarco.com/product-compliance>

for up to date information on any substances of concern that may be contained within this product.

Where no additional information is provided on the Spirax Sarco product compliance web page, this product may be safely recycled and/or disposed providing due care is taken. Always check your local recycling and disposal regulations.

## 1.16 Returning products

Customers and stockists are reminded that under EC Health, Safety and Environment Law, when returning products to Spirax Sarco they must provide information on any hazards and the precautions to be taken due to contamination residues or mechanical damage which may present a health, safety or environmental risk. This information must be provided in writing including Health and Safety data sheets relating to any substances identified as hazardous or potentially hazardous.

## 2. General product information

### 2.1 General description

The IF Monnier international range of filters provides high quality compressed air (free from liquid and solid contaminants) for general purpose pneumatic systems.

#### Available types

---

**IF2M** Only available with a metal bowl and having a manual drain.

---

**IF2AM** Having a pilot operated automatic drain.

---

**IF2DM** Having a semi-automatic dump valve with quick action manual override.

---

#### Principal features:

- Internal and external high quality black anodised finish.
- Large filter element for long life and low pressure drop.
- Shrouded whirl disc for efficient separation.
- 5 micron large surface area element.
- Options of metal bowl with sight level.

#### Optional extras

For further data regarding the following options see Technical Information sheet TI-P504-11:

- Metal bowl with /without sight glass.
- Bowl guard.

### 2.2 Sizes and pipe connections

¼", ⅜" and ½" screwed BSP T Rp (ISO 7-1).

### 2.3 Operating limits

---

<b>Maximum working pressure</b>	Polycarbonate bowl	10 bar g @ 50 °C	(145 psi g @ 122 °F)
	Metal bowl	17 bar g @ 80 °C	(246.5 psi g @ 176 °F)
<b>Maximum working temperature</b>	Polycarbonate bowl	50 °C @ 10 bar g	(122 °F @ 145 psi g)
	Metal bowl	80 °C @ 17 bar g	(176 °F @ 246.5 psi g)

---

---

IF2M, IF2AM and IF2DM Monnier International Compressed Air Filters

## 2.4 Materials

Part	Material
Bowl	Polycarbonate or aluminium (anodised)
Head	Anodised aluminium
Element 5 µm	Melamine impregnated cellulose
'O' rings	Nitrile rubber
Auto-drain	Plastic



Fig. 1 IF2M, IF2AM and IF2DM Monnier international compressed air filter

# 3. Installation and commissioning

**Note:** Before actioning any installation observe the 'Safety information' in Section 1.

Referring to the Installation and Maintenance Instructions, name-plate and Technical Information Sheet, check that the product is suitable for the intended installation.

## 3.1 Specific product safety information

Polycarbonate bowls may be attacked by phosphate ester based fluids, solvents, chemical cleaners, carbon tetrachloride, etc. These and any other substances should not be allowed to come into contact with this component. Certain compressor lubricating oils also contain additives harmful to polycarbonate. Where there is any doubt we recommend, in the interests of personal safety, that bowl guards or metal bowls be fitted.

## 3.2 Installation

- 3.3.1** The unit should be fitted in horizontal pipework with the bowl vertically downwards.
- 3.3.2** Adequate space should be provided around the unit to allow easy access for routine servicing requirements (see TI-P504-11 for withdrawal distances).
- 3.3.3** Connect the unit so that the airflow is in the direction indicated by the arrow on the body.
- 3.3.4** The unit should be installed as close as possible to the equipment it is serving.
- 3.3.5** Do not overload the filter cartridge (see Section 4 - Operating principals) or there will be a reduction in its efficiency and/or life. On heavily contaminated systems, it is advisable to fit a conventional pneumatic filter (Monnier International or Miniature) immediately in front of the unit for maximum efficiency and life cycle.
- 3.3.6** The polycarbonate bowl may be fitted with a bowl guard.

## 4. Operation

### 4.1 Principle of operation

Monnier air line filters are built to ensure solid and liquid contaminants are removed from compressed air. All Monnier filters are engineered with the exclusive Whirl-Away design which creates high centrifugal force with low pressure drop. The whirling action forces all liquids and solids against the bowl wall causing them to run down below the quiet-zone baffle where they can be drained out. The air then flows through the element where the smaller particles are removed and the filtered air passes downstream. The leak proof drain valve has an 'O' ring seal that can be opened and closed without tools.

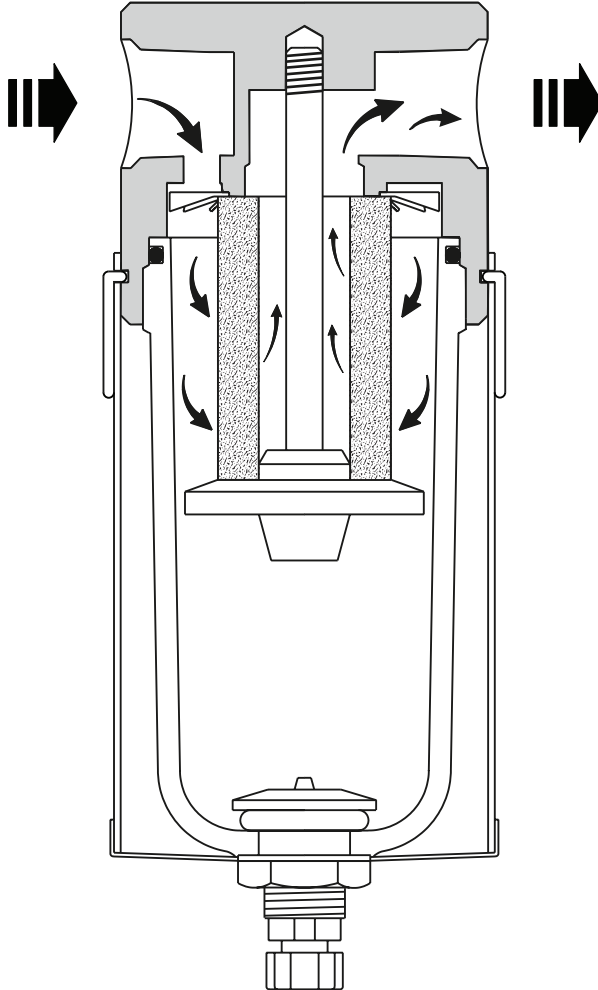



## 4.2 Performance selection (with primary pressure 10 bar)

For any specified primary filtration pressure, there is a maximum recommended air flowrate. Keeping within this, will ensure that the element performance maintains the stated high efficiency levels, particularly for the removal of oil and water contaminants.

## 4.3 Capacities

5 µm element

1/4"

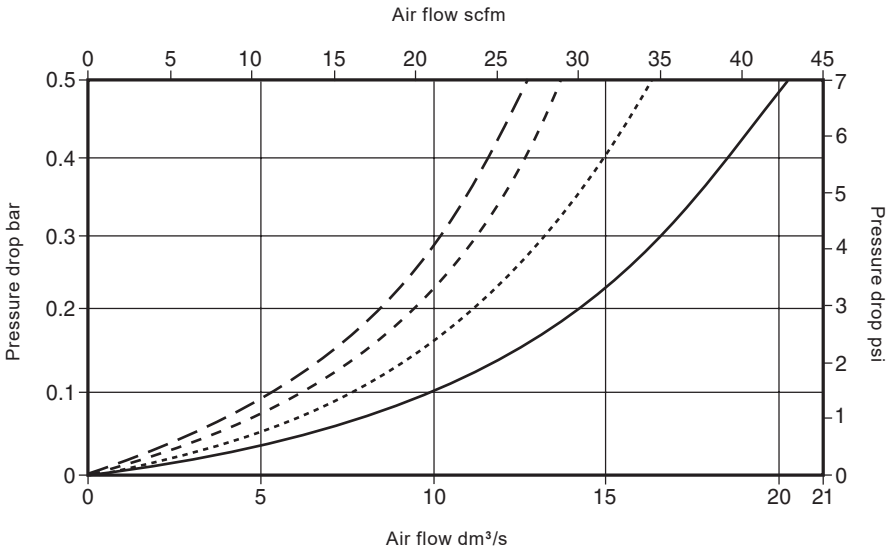
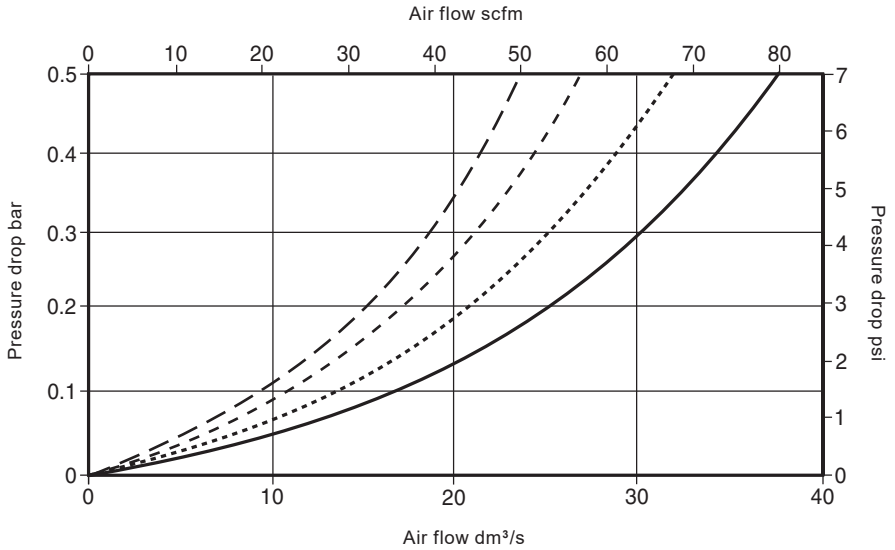

Fig. 2 IF2DM shown



3/8"



**Key for chart**

— — — — — 1.6 bar g (23 psi g)  
- - - - - 2.5 bar g (36 psi g)

..... 4.0 bar g (58 psi g)  
————— 6.3 bar g (91 psi g)

1/2"

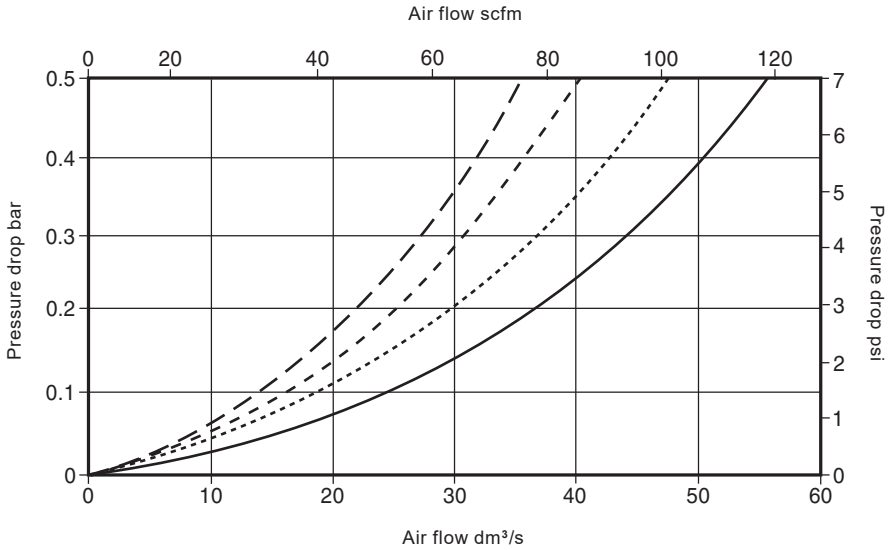

**Key for chart**

— — — — — 1.6 bar g (23 psi g)  
- - - - - 2.5 bar g (36 psi g)

..... 4.0 bar g (58 psi g)  
————— 6.3 bar g (91 psi g)

# 5. Spare parts and maintenance

## 5.1 Spare parts

The spare parts available are detailed below. No other parts are supplied as spares.

### Available spares

Bowl assembly including the appropriate drain - state polycarbonate or metal (with or without sight level)	A, B
Element set (packet of 3 of each) 5 µm	B, C
Auto-drain (IF2AM only)	Not shown

**Note:** In the interests of safety Spirax Sarco recommend that a bowl guard (an optional extra) should be fitted to polycarbonate bowls.

### How to order spares

Always order spares by using the description given in the column headed 'Available spares' and state the size and type of unit.

**Example:** 1 off Polycarbonate bowl assembly for a 1/2" IF2DM Monnier international compressed air filter.

## 5.2 Maintenance

To service the filter (no tools required):

- Isolate the main air supply.
- Remove the bowl guard if fitted.
- Release the pressure by opening the manual drain or gently unscrewing the bowl (A) until the pressure relieves.
- Remove the bowl (A) and unscrew the element retaining nut and withdraw the filter assembly (C).
- Clean the bowl (A) using soap and water only (do not use solvents or proprietary cleaners) and wipe dry with a lint free cloth.
- Reassemble in reverse order using a new element (C), ensuring that the element 'O' ring (B) is fitted.
- The bowl should be firmly hand tightened.

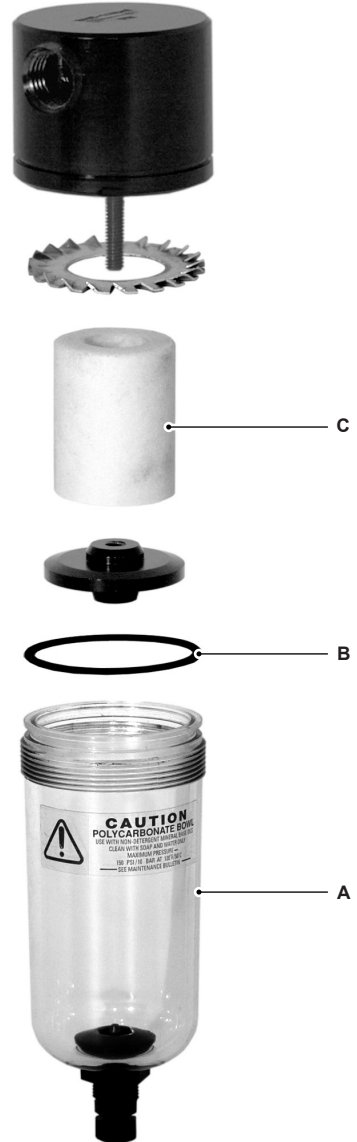

Fig. 3 Spare parts