

HP45
Bimetallic Steam Trap
Installation and Maintenance Instructions

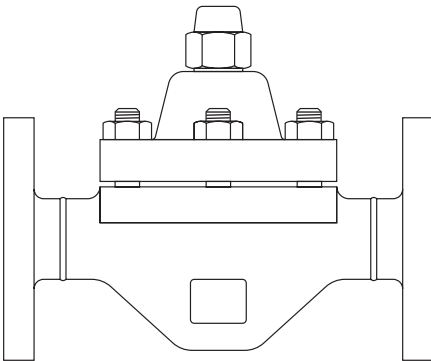

- 1. Safety information*
- 2. General product information*
- 3. Installation*
- 4. Commissioning*
- 5. Operation*
- 6. Maintenance*
- 7. Spare parts*
- 8. Fault finding*

1. Safety information

Safe operation of this product can only be guaranteed if it is properly installed, commissioned, used and maintained by qualified personnel (see Section 1.11) in compliance with the operating instructions. General installation and safety instructions for pipeline and plant construction, as well as the proper use of tools and safety equipment must also be complied with.

1.1 Intended use

Referring to the Installation and Maintenance Instructions, name-plate and Technical Information Sheet, check that the product is suitable for the intended use/application. The product listed below complies with the requirements of the European Pressure Equipment Directive 97/23/EC and carries the CE mark when so required. The product falls within the following Pressure Equipment Directive categories:

Product	Group 2 Gases	Group 2 Liquids
HP45	SEP	SEP

- i) The product has been specifically designed for use on steam, air or water/condensate which are in Group 2 of the above mentioned Pressure Equipment Directive. The products' use on other fluids may be possible but, if this is contemplated, Spirax Sarco should be contacted to confirm the suitability of the product for the application being considered.
- ii) Check material suitability, pressure and temperature and their maximum and minimum values. If the maximum operating limits of the product are lower than those of the system in which it is being fitted, or if malfunction of the product could result in a dangerous overpressure or overtemperature occurrence, ensure a safety device is included in the system to prevent such over-limit situations.
- iii) Determine the correct installation situation and direction of fluid flow.
- iv) Spirax Sarco products are not intended to withstand external stresses that may be induced by any system to which they are fitted. It is the responsibility of the installer to consider these stresses and take adequate precautions to minimise them.
- v) Remove protection covers from all connections before installation.

1.2 Access

Ensure safe access and if necessary a safe working platform (suitably guarded) before attempting to work on the product. Arrange suitable lifting gear if required.

1.3 Lighting

Ensure adequate lighting, particularly where detailed or intricate work is required.

1.4 Hazardous liquids or gases in the pipeline

Consider what is in the pipeline or what may have been in the pipeline at some previous time. Consider: flammable materials, substances hazardous to health, extremes of temperature.

1.5 Hazardous environment around the product

Consider: explosion risk areas, lack of oxygen (e.g. tanks, pits), dangerous gases, extremes of temperature, hot surfaces, fire hazard (e.g. during welding), excessive noise, moving machinery.

1.6 The system

Consider the effect on the complete system of the work proposed. Will any proposed action (e.g. closing isolation valves, electrical isolation) put any other part of the system or any personnel at risk?

Dangers might include isolation of vents or protective devices or the rendering ineffective of controls or alarms. Ensure isolation valves are turned on and off in a gradual way to avoid system shocks.

1.7 Pressure systems

Ensure that any pressure is isolated and safely vented to atmospheric pressure. Consider double isolation (double block and bleed) and the locking or labelling of closed valves. Do not assume that the system has depressurised even when the pressure gauge indicates zero.

1.8 Temperature

Allow time for temperature to normalise after isolation to avoid danger of burns.

1.9 Tools and consumables

Before starting work ensure that you have suitable tools and/or consumables available. Use only genuine Spirax Sarco replacement parts.

1.10 Protective clothing

Consider whether you and/or others in the vicinity require any protective clothing to protect against the hazards of, for example, chemicals, high/low temperature, radiation, noise, falling objects, and dangers to eyes and face.

1.11 Permits to work

All work must be carried out or be supervised by a suitably competent person. Installation and operating personnel should be trained in the correct use of the product according to the Installation and Maintenance Instructions.

Where a formal 'permit to work' system is in force it must be complied with. Where there is no such system, it is recommended that a responsible person should know what work is going on and, where necessary, arrange to have an assistant whose primary responsibility is safety.

Post 'warning notices' if necessary.

1.12 Handling

Manual handling of large and/or heavy products may present a risk of injury. Lifting, pushing, pulling, carrying or supporting a load by bodily force can cause injury particularly to the back. You are advised to assess the risks taking into account the task, the individual, the load and the working environment and use the appropriate handling method depending on the circumstances of the work being done.

1.13 Residual hazards

In normal use the external surface of the product may be very hot. If used at the maximum permitted operating conditions the surface temperature of some products may reach temperatures in excess of 425°C (797°F).

Many products are not self-draining. Take due care when dismantling or removing the product from an installation (refer to 'Maintenance instructions').

1.14 Freezing

Provision must be made to protect products which are not self-draining against frost damage in environments where they may be exposed to temperatures below freezing point.

1.15 Disposal

Unless otherwise stated in the Installation and Maintenance Instructions, this product is recyclable and no ecological hazard is anticipated with its disposal providing due care is taken.

1.16 Returning products

Customers and stockists are reminded that under EC Health, Safety and Environment Law, when returning products to Spirax Sarco they must provide information on any hazards and the precautions to be taken due to contamination residues or mechanical damage which may present a health, safety or environmental risk. This information must be provided in writing including Health and Safety data sheets relating to any substances identified as hazardous or potentially hazardous.

— 2. General product information —

2.1 General description

The Spirax Sarco HP45 bimetallic steam trap is made of forged steel, and designed for draining high pressure, high temperature steam lines and processes.

This steam trap is specially designed for HP steam and has a reinforced stainless steel insert within the body and can be repaired inline. It operates with no loss of steam, and quickly drains air, non-condensable gases and large quantities of cold water on start-up. Normally open in the event of failure, it has a check valve, a built-in strainer screen and an external device for adjusting the discharge temperature of the condensate.

Standards

This product fully complies with the requirements of the European Pressure Equipment Directive 97/23/EC.

Certification

This product is available with certification to EN 10204 3.1 **Note:** All certification/inspection requirements must be stated at the time of order placement.

Note:

For additional information see Technical Information Sheet TI-P623-02.

2.2 Sizes and pipe connections

½", ¾" and 1"

screwed BSP/NPT, socket weld ends to ANSI B 16.11 and butt weld ends to ANSI B 16.25.
DN15, DN20 and DN25 flanged PN63, PN100 and ANSI 600.

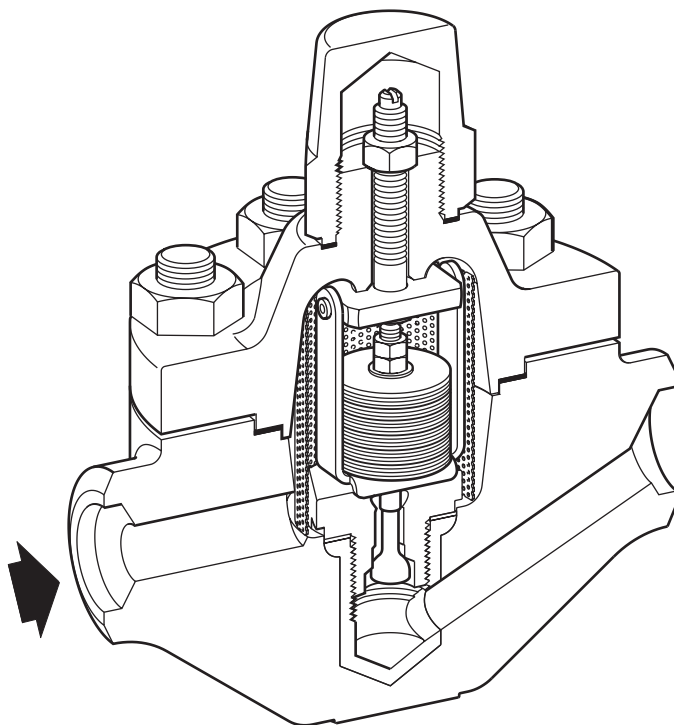
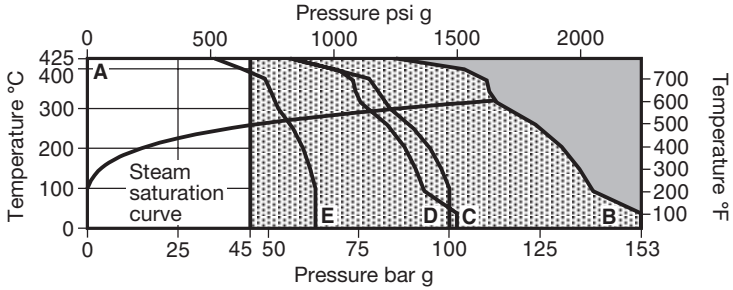



Fig. 1

2.3 Pressure / temperature limits



 The product **must not** be used in this region.

 The product should not be used in this region or beyond its operating range as damage to the internals may occur.

- A - B Screwed BSP/NPT, socket weld and butt weld ends.
- A - C Flanged ANSI 600.
- A - D Flanged PN100.
- A - E Flanged PN63.

Body design conditions	PN150, Class 900 to ANSI B 16.34	
PMA Maximum allowable pressure	153 bar g @ 38°C	(2 219 psi g @ 100°F)
TMA Maximum allowable temperature	425°C @ 86 bar g	(797°F @ 1 247 psi g)
Minimum allowable temperature	0°C	(32°F)
PMO Maximum operating pressure	45 bar g @ 425°C	(653 psi g @ 797°F)
TMO Maximum operating temperature	425°C @ 45 bar g	(797°F @ 653 psi g)
Minimum operating temperature	0°C	(32°F)
Note: For lower temperatures consult Spirax Sarco		
Minimum inlet pressure for satisfactory operation	15 bar g	(218 psi g)
ΔPMX Backpressure for correct operation must not exceed 90% of the upstream pressure		
Designed for a maximum cold hydraulic test pressure of:	229 bar g	(3 321 psi g)

3. Installation

Note: Before actioning any installation observe the 'Safety information' in Section 1.

Referring to the Installation and Maintenance Instructions, name-plate and Technical Information Sheet, check that the product is suitable for the intended installation:

- 3.1** Check materials, pressure and temperature and their maximum values. If the maximum operating limit of the product is lower than that of the system in which it is being fitted, ensure that a safety device is included in the system to prevent overpressurisation.
- 3.2** Determine the correct installation situation and the correct direction of fluid flow.
- 3.3** Remove protective covers from all connections and protective film from all name-plates, where appropriate, before installation on steam or other high temperature applications.
- 3.4** Install the steam trap downstream of the equipment to be drained, ensuring that it is easily accessible for inspection and maintenance.
- 3.5** The steam trap may be installed in any position, except discharge flowing vertically upward.
- 3.6** Before installing the trap, ensure all connecting pipework is clean and free of debris.
- 3.7** Mount the steam trap with the arrow on the body pointing in the direction of the flow of the liquid.
- 3.8** The steam trap can be welded onto the pipework without removing the internal components. If line freeze-up is a possibility, the axis of the bonnet should be installed horizontally. For socket welded traps, observe qualified welding procedures. It is not necessary to remove the trap internals when welding, but avoid excessive heat.
- 3.9** The steam trap is factory set.

Note: If the trap is to discharge to atmosphere ensure it is to a safe place, the discharging fluid may be at a temperature of 100°C (212°F).

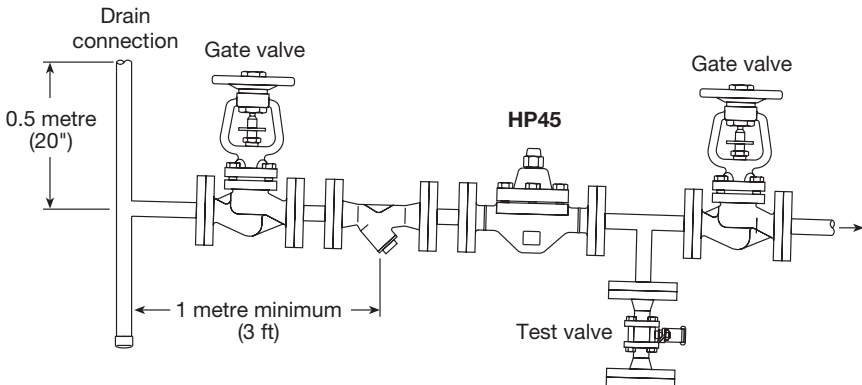

Fig. 3 Recommended installation - Note: pipework to fall in the direction of flow.

4. Commissioning

After installation or maintenance ensure that the system is fully functioning. Carry out tests on any alarms or protective devices.

5. Operation

The Spirax Sarco HP45 is a bimetallic steam trap.

This trap operates on the basis of two opposing forces acting on the valve - an opening force created by system pressure, and a closing force resulting from the condensate temperature acting on the bimetallic elements.

The HP45 steam trap operates with no loss of steam and automatically and quickly drains air, non-condensable gases and large quantities of cold water on start-up.

6. Maintenance

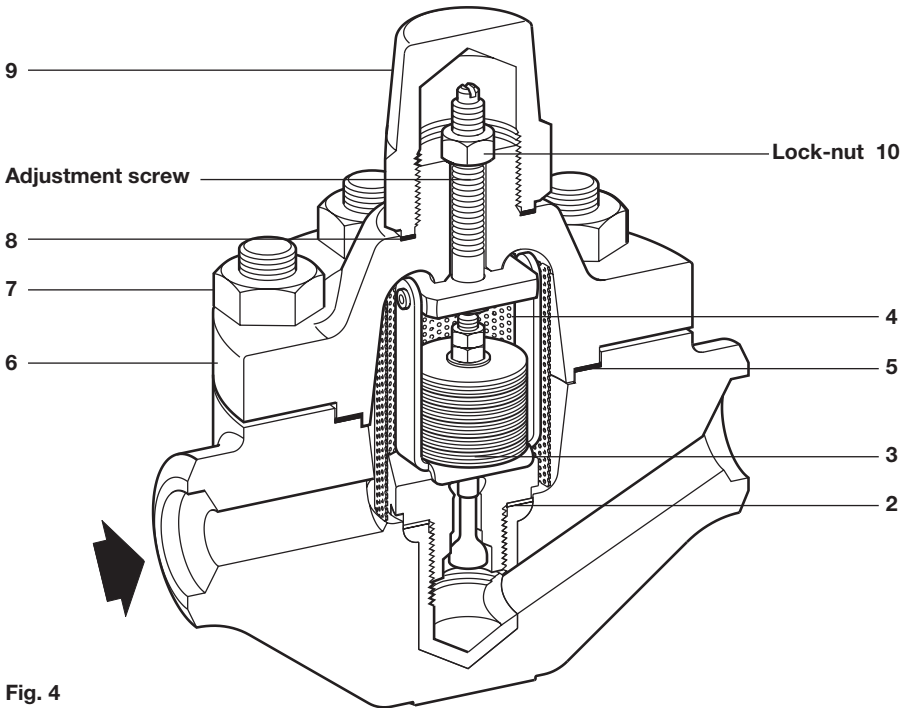



Fig. 4

Table 1 Spanners to be used and recommended tightening torques

Item	Part	 or  mm	N m	(lbf ft)
3	Bimetallic element - pipe spanner	36 A/F	120	(88)
7	Cover nut	22 A/F	80	(59)
9	Blind nut	29 A/F	50 - 55	(37 - 41)
10	Lock-nut on adjustment screw	13 A/F		

Note:

Before actioning any maintenance programme observe the 'Safety information' in Section 1.

Safety note:

These traps are installed in high pressure steam lines. Personnel doing the adjustment work should wear heavy gloves, long sleeve shirt, and other safety equipment designed to protect the wearer (goggles, face shield, etc.) in the event of a leak.

The equipment needed to proceed with any maintenance programme is listed in Table 1. The HP45 trap has an external adjustment screw which permits flushing the trap seat and setting the discharge temperature of the condensate in the inlet line.

Maintenance can be completed with the trap in the pipeline, once the safety procedures have been observed. It is recommended that new gaskets and spares are used whenever maintenance is undertaken. Ensure that the correct tools and necessary protective equipment are used at all times. When maintenance is complete open isolation valves slowly and check for leaks.

6.1 Trap seat flushing during operation

To clean the steam trap during operation or adjust it, it is advisable to close the upstream isolation valve before turning the adjustment screw, and proceed as follows: (in a closed return system, close the discharge line and open the test valve):

- Remove the blind nut (9) and loosen the lock-nut (10) on the adjustment screw.
- Using a screwdriver, tighten the adjustment screw a few turns, clockwise. This completely disengages the valve inlet.
- Open the upstream isolation valve slightly. This causes a strong purging action, which removes any impurities that may have been deposited in the steam trap.
- Move the adjustment screw up (turning it anticlockwise) until the valve comes into contact with the valve seat.

6.2 Discharge temperature adjustment:

- Remove the blind nut (9) and loosen the lock-nut (10) on the adjustment screw.
- The discharge temperature of the condensate is adjusted by moving the adjustment screw up a greater or lesser amount from the point where the valve is in contact with the valve seat (**standard adjustment, turn the screw an additional ¼ to ½ turn anticlockwise**).
- Tighten the lock-nut (10) on the adjustment screw when the adjustment has been completed.
- Replace the blind nut (9) and gasket (8) and tighten to the specified torque (see Table 1).
- Shut the test valve and open the discharge line valve. In a closed return system, a test tee and valve must be used to observe trap operation. The trap should modulate the condensate discharge depending on inlet temperature and pressure.
- Open the upstream isolation valve fully when the adjustment has been completed.

6.3 Replacing the bimetallic element

Spares available to repair (See Section 7).



6.3.1 Dismantling the steam trap:

- Isolate the steam trap.
- Remove the blind nut (9), the lock-nut (10) on the adjustment screw and the cover nuts (7) on the cover (6).
- Tighten the adjustment screw on the unit to disengage it from the cover using a screwdriver (maximum blade diameter 7 mm in order to insert it into the thread on the cover).
- Remove the strainer screen (4).
- Dismantle the bimetallic element (3) using a pipe spanner. For this operation it is advisable to use a special purpose 36 mm A/F pipe spanner.
- Insert the bimetallic element in the pipe spanner. Remove the internals (3) by unscrewing the seat from the body using a 17/16" (36 mm) hex spanner.
- Inspect all parts, particularly gasket and sealing surfaces.

6.3.2 Reassembling the steam trap:

- It is essential to use the new gaskets supplied in the spares replacement kit (see Section 7).
- Grease the threads on the valve seat, adjustment screw and valve seat gasket seating surfaces.
- Position the valve seat gasket (2) in the valve casing.
- Screw in the bimetallic element (3) using the pipe spanner and tighten it to the recommended torque (See Table 1).
- Place the strainer screen (4) and the cover gasket (5) in position.
- Screw the cover onto the adjustment screw using the screwdriver inserted in the cover and move the adjustment screw anticlockwise until it is above the cover.
- Grease the cover nuts (7) and replace them onto the cover studs. Then tighten the nuts to the recommended torque (see Table 1).
- **Place the lock-nut (10) in position on the adjustment screw, then proceed to make the final adjustment. (See Section 6.3.3).**

Table 1 Spanners to be used and recommended tightening torques

Item	Part	 or  mm	N m	(lbf ft)
3	Bimetallic element - pipe spanner	36 A/F	120	(88)
7	Cover nut	22 A/F	80	(59)
9	Blind nut	29 A/F	50 - 55	(37 - 41)
10	Lock-nut on adjustment screw	13 A/F		

6.3.3 Adjustment:

- In a closed return system, close the discharge line and open the test valve.
- Open the upstream isolation valve slightly.
- Tighten the adjustment screw a few turns clockwise, and wait a few moments for the steam trap to reach the required temperature and for steam to be present.
- Move the adjustment screw up (anticlockwise) until the valve comes into contact with the valve seat.
- The condensate discharge temperature is adjusted by moving the adjustment screw up a greater or lesser amount from the point at which the valve and the valve seat are in contact (**standard adjustment, turn the screw an additional $\frac{1}{4}$ to $\frac{1}{2}$ turn anticlockwise**).
- Tighten the lock-nut (10) onto the adjustment screw once the adjustment has been completed.
- Replace the blind nut (9) and gasket (8) and tighten to the specified torque (see Table 1).
- Shut the test valve and open the discharge line valve. In a closed return system, a test tee and valve must be used to observe trap operation. The trap should modulate the condensate discharge depending on inlet temperature and pressure.
- Open the upstream isolation valve fully once the adjustment has been completed.

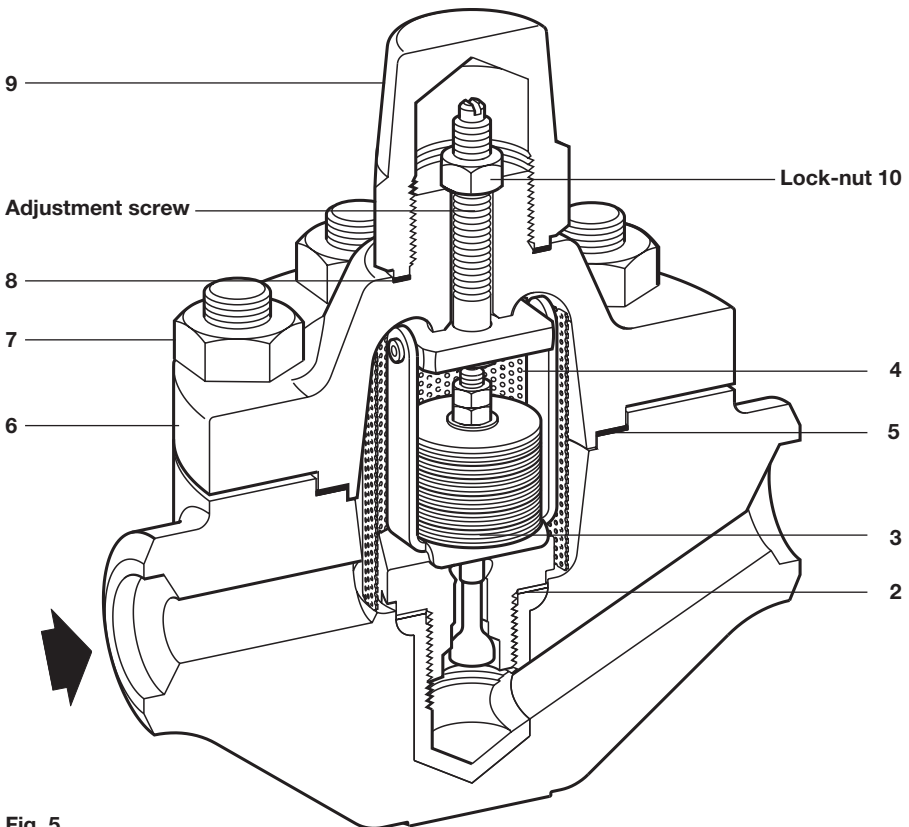

Fig. 5

7. Spare parts

The spare parts available are detailed below. No other parts are supplied as spares.

Available spares

Bimetallic assembly kit

2, 3, 4, 5, 8

How to order spares

Always order spares by using the description in the column headed 'Available spares' and state the size and model of the bimetallic steam trap.

Example: 1 - Bimetallic assembly kit for a Spirax Sarco DN20 HP45 bimetallic steam trap.

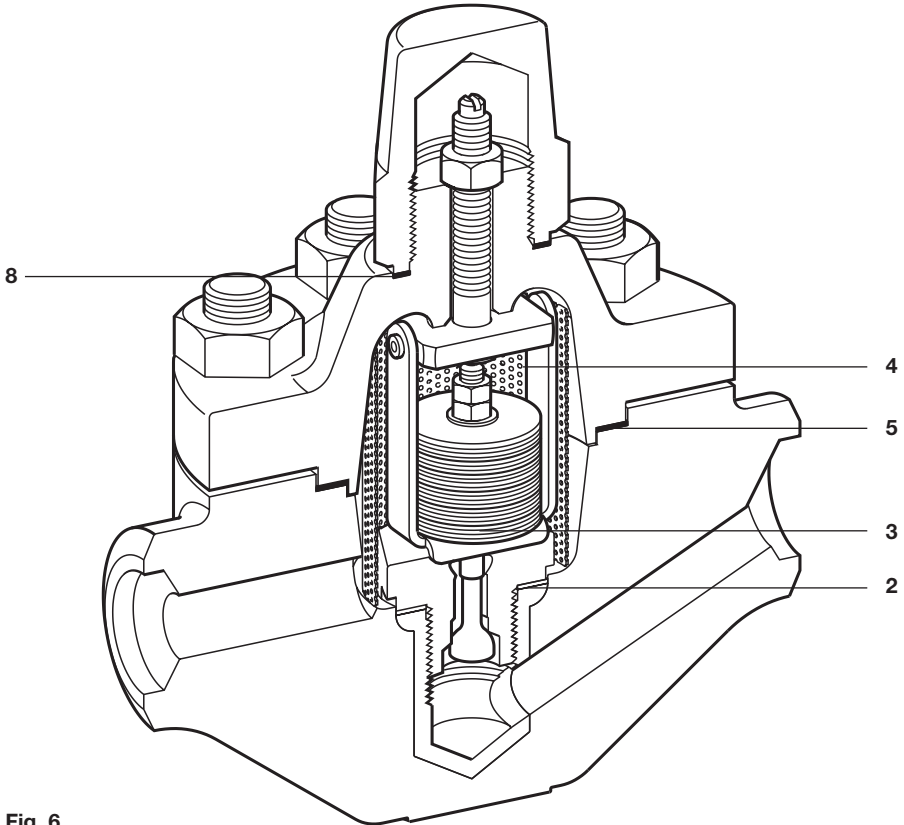

Fig. 6

8. *Fault finding*

Trap fails to pass condensate	<ol style="list-style-type: none">1. Make sure upstream and downstream valves are open.2. Check external strainers for clogging; blowdown or dismantle and clean.3. Backpressure too high. Downstream system must be corrected. Backpressure will also lower the discharge temperature.4. Valve port clogged with dirt. Follow 'Trap seat flushing' procedure (See Section 6.1).5. Bimetallic element improperly adjusted. Adjust as described under 'Discharge temperature adjustment' (See Section 6.2).6. Dismantle and inspect internals. See 'Dismantling the steam trap' (See Section 6.3.1).
Trap blows live steam	<ol style="list-style-type: none">1. Dirt on seating surface. Flush as described in 'Trap seat flushing' procedure (See Section 6.1).2. Bimetallic element improperly adjusted. Adjust as described under 'Discharge temperature adjustment' (See Section 6.2).3. Worn valve seat. Dismantle, inspect and replace if necessary.



