

FTGS14HC

**Ball Float Steam Trap
(1" screwed)**

Installation and Maintenance Instructions

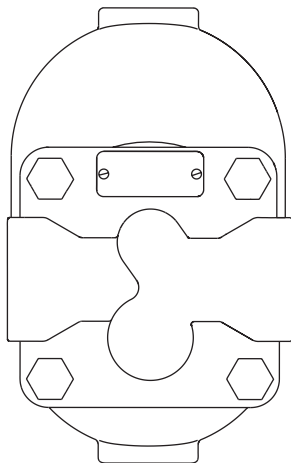

1. Safety information
2. General product information
3. Installation
4. Commissioning
5. Operation
6. Maintenance
7. Spare parts

FTGS14HC Ball Float Steam Trap (1" screwed)



1. Safety information

Safe operation of this product can only be guaranteed if it is properly installed, commissioned, used and maintained by qualified personnel (see Section 1.11) in compliance with the operating instructions. General installation and safety instructions for pipeline and plant construction, as well as the proper use of tools and safety equipment must also be complied with.

Warning

The cover gasket contains a thin stainless steel support ring which may cause physical injury if not handled and disposed of carefully.

1.1 Intended use

Referring to the Installation and Maintenance Instructions, name-plate and Technical Information Sheet, check that the product is suitable for the intended use/application. The product listed below complies with the requirements of the European Pressure Equipment Directive 2014/68/EU and falls within category 'SEP'.

It should be noted that products within this category are required by the Directive not to carry the  mark.

- i) The product has been specifically designed for use on steam, air or water/condensate which is in Group 2 of the above mentioned Pressure Equipment Directive. The products' use on other fluids may be possible but, if this is contemplated, Spirax Sarco should be contacted to confirm the suitability of the product for the application being considered.
- ii) Check material suitability, pressure and temperature and their maximum and minimum values. If the maximum operating limits of the product are lower than those of the system in which it is being fitted, or if malfunction of the product could result in a dangerous overpressure or overtemperature occurrence, ensure a safety device is included in the system to prevent such over-limit situations.
- iii) Determine the correct installation situation and direction of fluid flow.
- iv) Spirax Sarco products are not intended to withstand external stresses that may be induced by any system to which they are fitted. It is the responsibility of the installer to consider these stresses and take adequate precautions to minimise them.
- v) Remove protection covers from all connections and protective film from all name-plates, where appropriate, before installation on steam or other high temperature applications.

1.2 Access

Ensure safe access and if necessary a safe working platform (suitably guarded) before attempting to work on the product. Arrange suitable lifting gear if required.

1.3 Lighting

Ensure adequate lighting, particularly where detailed or intricate work is required.

1.4 Hazardous liquids or gases in the pipeline

Consider what is in the pipeline or what may have been in the pipeline at some previous time. Consider: flammable materials, substances hazardous to health, extremes of temperature.

1.5 Hazardous environment around the product

Consider: explosion risk areas, lack of oxygen (e.g. tanks, pits), dangerous gases, extremes of temperature, hot surfaces, fire hazard (e.g. during welding), excessive noise, moving machinery.

1.6 The system

Consider the effect on the complete system of the work proposed. Will any proposed action (e.g. closing isolation valves, electrical isolation) put any other part of the system or any personnel at risk?

Dangers might include isolation of vents or protective devices or the rendering ineffective of controls or alarms. Ensure isolation valves are turned on and off in a gradual way to avoid system shocks.

1.7 Pressure systems

Ensure that any pressure is isolated and safely vented to atmospheric pressure. Consider double isolation (double block and bleed) and the locking or labelling of closed valves. Do not assume that the system has depressurised even when the pressure gauge indicates zero.

1.8 Temperature

Allow time for temperature to normalise after isolation to avoid danger of burns.

1.9 Tools and consumables

Before starting work ensure that you have suitable tools and/or consumables available. Use only genuine Spirax Sarco replacement parts.

1.10 Protective clothing

Consider whether you and/or others in the vicinity require any protective clothing to protect against the hazards of, for example, chemicals, high/low temperature, radiation, noise, falling objects, and dangers to eyes and face.

1.11 Permits to work

All work must be carried out or be supervised by a suitably competent person.

Installation and operating personnel should be trained in the correct use of the product according to the Installation and Maintenance Instructions.

Where a formal 'permit to work' system is in force it must be complied with. Where there is no such system, it is recommended that a responsible person should know what work is going on and, where necessary, arrange to have an assistant whose primary responsibility is safety.

Post 'warning notices' if necessary.

1.12 Handling

Manual handling of large and/or heavy products may present a risk of injury. Lifting, pushing, pulling, carrying or supporting a load by bodily force can cause injury particularly to the back. You are advised to assess the risks taking into account the task, the individual, the load and the working environment and use the appropriate handling method depending on the circumstances of the work being done.

1.13 Residual hazards

In normal use the external surface of the product may be very hot. If used at the maximum permitted operating conditions the surface temperature of some products may reach temperatures in excess of 250 °C (482 °F).

Many products are not self-draining. Take due care when dismantling or removing the product from an installation (refer to 'Maintenance instructions').

1.14 Freezing

Provision must be made to protect products which are not self-draining against frost damage in environments where they may be exposed to temperatures below freezing point.

1.15 Disposal

Unless otherwise stated in the Installation and Maintenance Instructions, this product is recyclable and no ecological hazard is anticipated with its disposal providing due care is taken.

Please visit the Spirax Sarco product compliance web pages

<https://www.spiraxsarco.com/product-compliance>

for up to date information on any substances of concern that may be contained within this product. Where no additional information is provided on the Spirax Sarco product compliance web page, this product may be safely recycled and/or disposed providing due care is taken. Always check your local recycling and disposal regulations.

1.16 Returning products

Customers and stockists are reminded that under EC Health, Safety and Environment Law, when returning products to Spirax Sarco they must provide information on any hazards and the precautions to be taken due to contamination residues or mechanical damage which may present a health, safety or environmental risk. This information must be provided in writing including Health and Safety data sheets relating to any substances identified as hazardous or potentially hazardous.

2. General product information

2.1 General description

The FTGS14HC ball float steam trap has an austenitic stainless steel body, stainless steel working internals and integral automatic air venting facility. The SG iron cover is electroless nickel-plated offering increased resistance to erosion. This trap is supplied with horizontal screwed connections and can be maintained without disturbing the pipework.

Available options

FTGS14HC (R-L)	Horizontal connections with flow from right to left
-----------------------	---

FTGS14HC (L-R)	Horizontal connections with flow from left to right
-----------------------	---

Note: If the orientation has to be changed on site - consult Spirax Sarco

Capsule

The BP99/32 capsule which is used in the FTGS14HC ball float steam trap is suitable for use on 150 °C superheat @ 0 bar g and 50 °C superheat @ 32 bar g.

Optional extras

A **manually adjustable needle valve** (designated 'C' on the nomenclature i.e. **FTGS14HC-C**) can be fitted to the trap. This option provides a **steam lock release (SLR)** feature in addition to the standard air vent. For further information please consult Spirax Sarco.

The top of the cover can be drilled and tapped $\frac{3}{8}$ " BSP T Rp (ISO 7-1) or NPT for the purpose of fitting a balance line if requested at the point of order.

The bottom of the cover can be drilled and tapped $\frac{3}{8}$ " BSP T Rp (ISO 7-1) or NPT for the purpose of fitting a drain cock if requested at the point of order.

Standards

This product fully complies with the requirements of the European Pressure Equipment Directive 2014/68/EU.

Certification

This product is available with a manufacturers Typical Test Report.

Note: All certification/inspection requirements must be stated at the time of order placement.

Note:

For further product data see the following Technical Information Sheets, TI-P145-19, TI-S02-28 and TI-S02-46.

2.2 Sizes and pipe connections

1" screwed BSP T Rp (ISO 7-1) or NPT.

FTGS14HC (L-R)

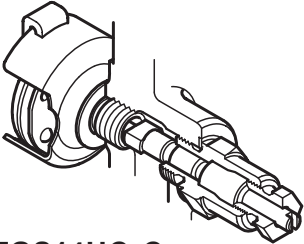
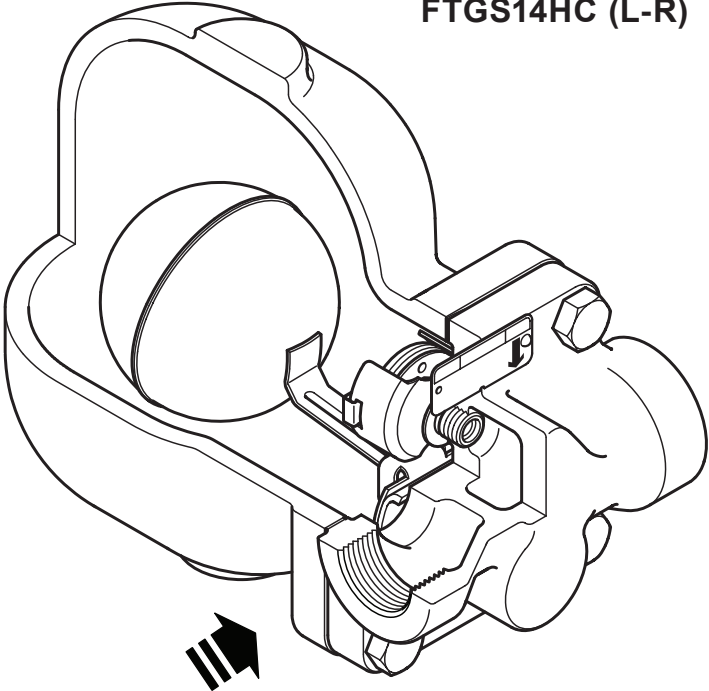
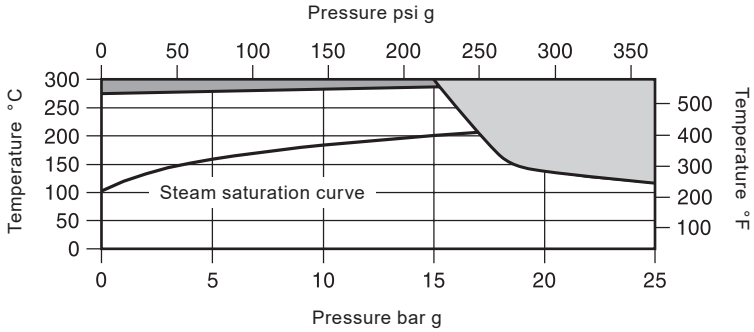

Fig. 1

FTGS14HC-C

FTGS14HC Ball Float Steam Trap (1" screwed)

2.3 Pressure /temperature limits



- The product **must not** be used in this region.
- The product should not be used in this region or beyond its operating range as damage to the internals may occur.

Body design conditions			PN25
PMA	Maximum allowable pressure	25 bar g @ 120 °C	(362 psi g @ 248 °F)
TMA	Maximum allowable temperature	300 °C	(572 °F)
	Minimum allowable temperature	-10 °C	(14 °F)
PMO	Maximum operating pressure for saturated steam service	17 bar g	(246 psi g)
TMO	Maximum operating temperature	288 °C @ 15 bar g	(550 °F @ 217 psi g)
	Minimum operating temperature	0 °C	(32 °F)
		FTGS14HC-4.5	4.5 bar (65 psi)
ΔPMX	Maximum differential pressure	FTGS14HC-10	10 bar (145 psi)
		FTGS14HC-14	14 bar (203 psi)
Designed for a maximum cold hydraulic test pressure of:		37.5 bar g	(544 psi g)

3. Installation

Note: Before actioning any installation observe the 'Safety information' in Section 1.

Referring to the Installation and Maintenance Instructions, name-plate and Technical Information Sheet, check that the product is suitable for the intended installation.

- 3.1** Check materials, pressure and temperature and their maximum values. If the maximum operating limit of the product is lower than that of the system in which it is being fitted, ensure that a safety device is included in the system to prevent overpressurisation.
- 3.2** Determine the correct installation situation and the direction of fluid flow.
- 3.3** Remove protection covers from all connections and protective film from all name-plates, where appropriate, before installation on steam or other high temperature applications.

- Installation notes:**
- If the trap is to discharge to atmosphere ensure it is to a safe place, the discharging fluid may be at a temperature of 100 °C (212 °F).
 - The trap must be fitted with the float arm in a horizontal plane so that it rises and falls vertically, therefore **the arrow on the name-plate must point downwards.**
 - Unless specified, traps will be supplied with horizontal left to right (L-R) connections. Right to left (R-L) connections are readily available on request but must be identified at the point of order.
 - Minimum withdrawal distance to remove the cover is 160 mm (6.3").

Installation of the manually adjustable needle valve

- 3.4** The manually adjustable needle valve is fitted to all float traps with the suffix 'C'. e.g. FTGS14-10C. 'C' = Combined steam lock release and thermostatic air vent (TV).
- 3.5** Check if the application requires the manually adjustable needle valve for correct operation. The manually adjustable needle valve should only be used to prevent 'steam locking' and therefore is designed to pass only a small amount of steam.
- 3.6** The manually adjustable needle valve will be dispatched, pre-set to a partial bleed condition. The unit should be screwed clockwise to close and anticlockwise to open. When required the manually adjustable needle valve should be used as a controlled continuous bleed, it is not recommended that the manually adjustable needle valve be left in the fully open condition as this may lead to premature trap failure and more frequent maintenance schedules.

Please consult Spirax Sarco should further information be required.

Warning: The cover gasket contains a thin stainless steel support ring which may cause physical injury if not handled and disposed of carefully.

4. Commissioning

After installation or maintenance ensure that the system is fully functioning. Carry out tests on any alarms or protective devices.

5. Operation

The float trap is a continuous discharge trap, removing condensate the instant it forms. On start-up, the thermostatic air vent allows air to bypass the main valve preventing the system air binding. Hot condensate will close the air vent tightly, but as soon as it enters the main chamber of the trap, the float rises and the lever mechanism attached to it opens the main valve - keeping the system drained of condensate at all times. When steam arrives, the float drops and closes the main valve. Float traps are renowned for their high start-up load handling capability, clean tight shut-off and resistance to waterhammer and vibration.

6. Maintenance

Note: Before actioning any maintenance programme observe the 'Safety information' in Section 1.

Warning

The cover gasket (3) contains a thin stainless steel support ring which may cause physical injury if not handled and disposed of carefully.

6.1 General information

Before undertaking any maintenance on the trap it must be isolated from both the supply line and return and any pressure allowed to safely normalise to atmosphere. The trap should then be allowed to cool. When reassembling, ensure that all joint faces are clean and that the dowel locates in the base.

6.2 How to fit the main valve assembly:

- Remove the cover from the body.
- Unscrew the support and pivot frame (9 and 10) and the valve seat (5 and 6).
- Ensure the seat/gasket faces are clean and dry.
- Fit the valve seat to the body (5 and 6 - Do not use gasket paste).
- Attach the support frame and pivot frame to the body with assembly set screws (7) but do not tighten.
- Fit the float arm (8) to the pivot frame using the pin (11) and by moving the complete assembly centre the valve head onto the seat orifice.
- Tighten the assembly set screws (7) to the recommended tightening torque (see Table 1).
- Refit the body (1) using a new gasket (3).
- Retighten the cover bolts/nuts (2) to the recommended tightening torque (see Table 1).

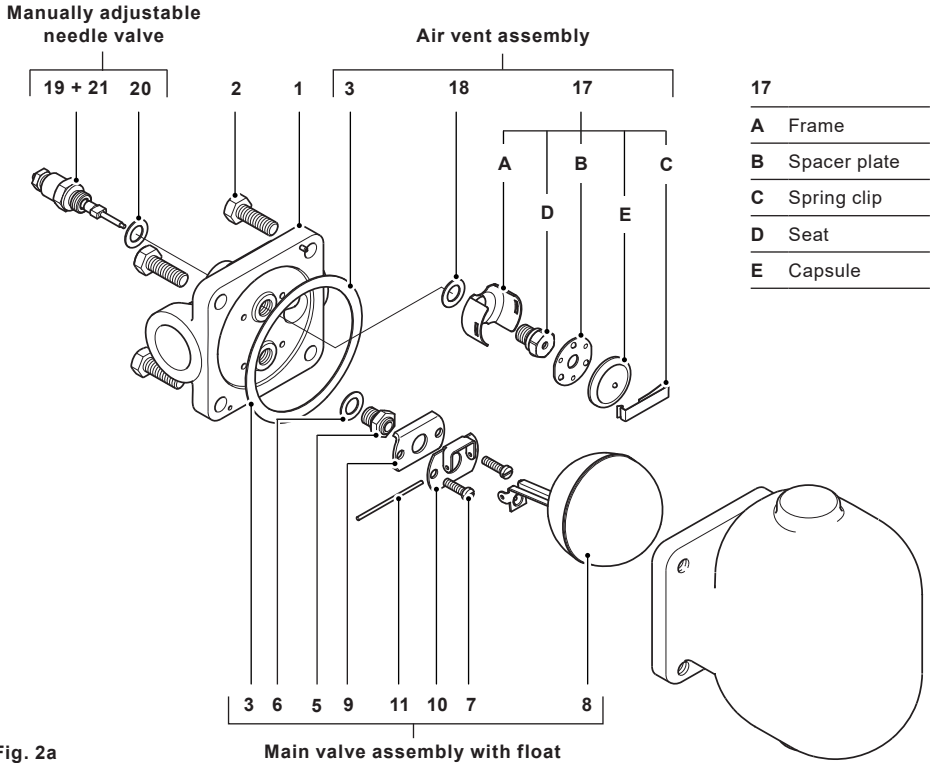



Fig. 2a

Table 1 Recommended tightening torques

Item	 or mm		N m	(lbf ft)
2	17 A/F	M10 x 30	29 - 33	(21.3 - 24.3)
5	17 A/F	-	40 - 45	(29.4 - 33.1)
7	-	M5 x 20	10 - 12	(7.3 - 8.8)
17	17 A/F	-	50 - 55	(36.8 - 40.4)
19	21 A/F	-	40 - 45	(29.4 - 33.1)

FTGS14HC Ball Float Steam Trap (1" screwed)

6.3 How to fit the air vent assembly:

- Remove the spring clip, capsule and spacer plate (17).
- Unscrew the seat.
- Fit a new gasket (18), seat and frame and tighten to the recommended tightening torque (see Table 1).
- Assemble the spacer plate and fit the capsule and clip.
- Align the complete air vent (17) horizontally so that the frame clears the cover.
- Refit the body (1) using a new gasket (3).
- Retighten the cover bolts/nuts (2) to the recommended tightening torque (see Table 1).

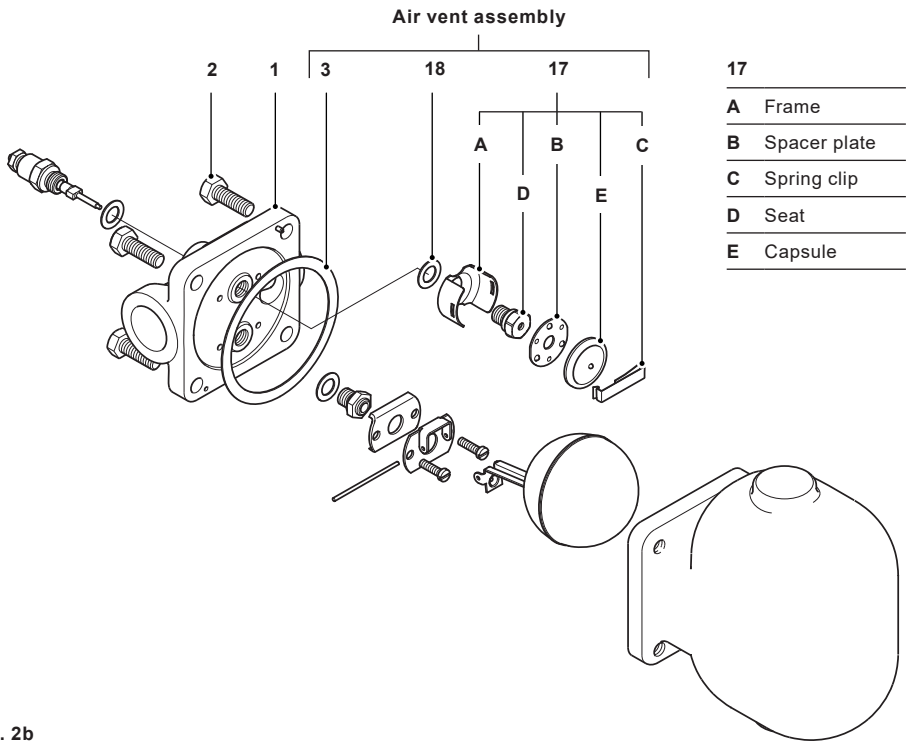

Fig. 2b

6.4 How to fit the manually adjustable needle valve (SLR assembly):

- Unscrew the complete SLR assembly (19 and 21).
- Remove the SLR gasket (20).
- Replace the SLR assembly (19 and 21) and gasket (20) with new ones.
- Tighten the SLR assembly to the recommended torque (see Table 1).
- To provide the maximum steam bleed turn the slotted SLR stem anticlockwise until the limit is reached. The amount of bleed can be adjusted by turning the SLR stem clockwise to close. The steam bleed will be fully closed within $\frac{3}{4}$ of a turn from fully open.

Manually adjustable
needle valve

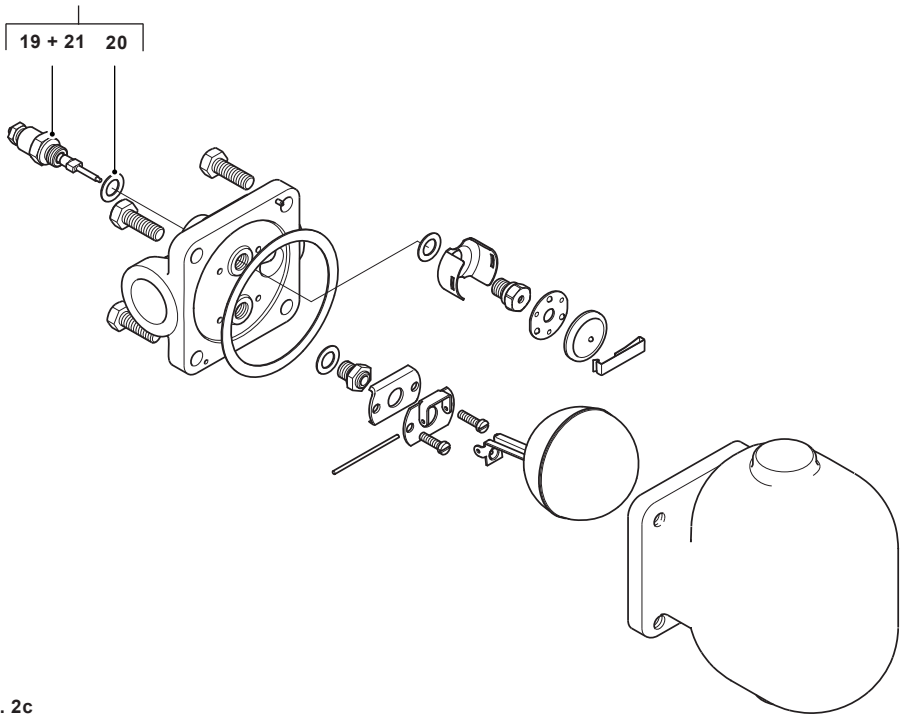

Fig. 2c

7. Spare parts

The spare parts available are shown in solid outline. Parts drawn in broken line are not supplied as spares.

Available spares

Maintenance kit	3, 5, 6, 7 (2 off), 8, 9, 10, 11, 17, 18
Main valve assembly with float	3, 5, 6, 7 (2 off), 8, 9, 10, 11
Air vent assembly	3, 17, 18
Manually adjustable needle valve (FTGS14HC-C only)	19 + 21, 20
Cover gasket (packet of 3)	3

How to order spares

Always order spares by using the description given in the column headed 'Available spares' and state the size, type of trap and pressure range.

Example: 1 - Main valve assembly with float for a Spirax Sarco 1" FTGS14HC-10 ball float steam trap.

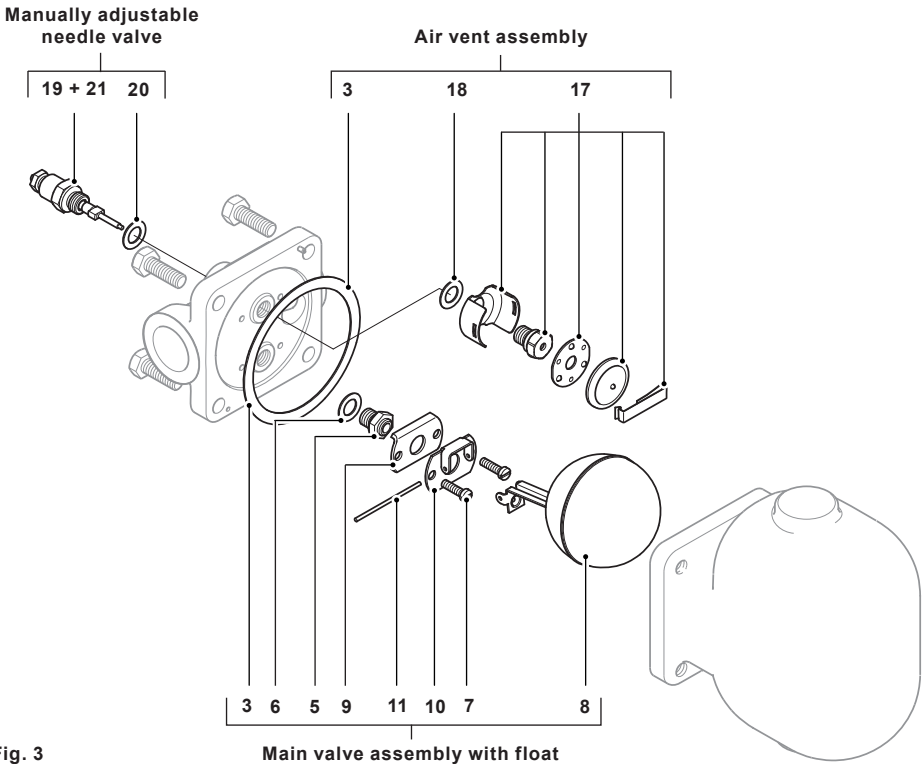

Fig. 3

FTGS14HC Ball Float Steam Trap (1" screwed)

FTGS14HC Ball Float Steam Trap (1" screwed)

FTGS14HC Ball Float Steam Trap (1" screwed)

