

FTC80

Cast Steel Ball Float Steam Trap
Installation and Maintenance Instructions

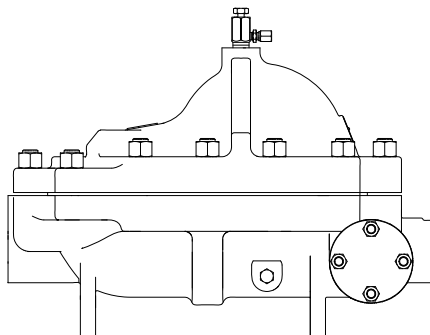

- 1. General safety information*
- 2. General product information*
- 3. Installation*
- 4. Commissioning*
- 5. Operation*
- 6. Maintenance*
- 7. Spare parts*

1. General safety information

Safe operation of this product can only be guaranteed if it is properly installed, commissioned, used and maintained by qualified personnel (see Section 1.11) in compliance with the operating instructions. General installation and safety instructions for pipeline and plant construction, as well as the proper use of tools and safety equipment must also be complied with.

1.1 Intended use

Referring to the Installation and Maintenance Instructions, name-plate and Technical Information Sheet, check that the product is suitable for the intended use/application. The FTC80 complies with the requirements of the European Pressure Equipment Directive 97/23/EC and carries the CE mark when so required. The product falls within the following Pressure Equipment Directive categories:

Product	Group 1	Group 2	Group 1	Group 2	
	Gases	Gases	Liquids	Liquids	
FTC80	DN40 (1½")	-	3	-	SEP
	DN50 (2")	-	3	-	SEP

- i) The product has been specifically designed for use on steam, air or water / condensate which is in Group 2 of the above mentioned Pressure Equipment Directive. The products' use on other fluids may be possible but, if this is contemplated, Spirax Sarco should be contacted to confirm the suitability of the product for the application being considered.
- ii) Check material suitability, pressure and temperature and their maximum and minimum values. If the maximum operating limits of the product are lower than those of the system in which it is being fitted, or if malfunction of the product could result in a dangerous overpressure or overtemperature occurrence, ensure a safety device is included in the system to prevent such over-limit situations.
- iii) Determine the correct installation situation and direction of fluid flow.
- iv) Spirax Sarco products are not intended to withstand external stresses that may be induced by any system to which they are fitted. It is the responsibility of the installer to consider these stresses and take adequate precautions to minimize them.
- v) Remove protection covers from all connections and protective film from all name-plates, where appropriate, before installation on steam or other high temperature applications.

1.2 Access

Ensure safe access and if necessary a safe working platform (suitably guarded) before attempting to work on the product. Arrange suitable lifting gear if required.

1.3 Lighting

Ensure adequate lighting, particularly where detailed or intricate work is required.

1.4 Hazardous liquids or gases in the pipeline

Consider what is in the pipeline or what may have been in the pipeline at some previous time. Consider: flammable materials, substances hazardous to health, extremes of temperature.

1.5 Hazardous environment around the product

Consider: explosion risk areas, lack of oxygen (e.g. tanks, pits), dangerous gases, extremes of temperature, hot surfaces, fire hazard (e.g. during welding), excessive noise, moving machinery.

1.6 The system

Consider the effect on the complete system of the work proposed. Will any proposed action (e.g. closing isolation valves, electrical isolation) put any other part of the system or any personnel at risk? Dangers might include isolation of vents or protective devices or the rendering ineffective of controls or alarms. Ensure isolation valves are turned on and off in a gradual way to avoid system shocks.

1.7 Pressure systems

Ensure that any pressure is isolated and safely vented to atmospheric pressure. Consider double isolation (double block and bleed) and the locking or labelling of closed valves. Do not assume that the system has depressurised even when the pressure gauge indicates zero.

1.8 Temperature

Allow time for temperature to normalise after isolation to avoid the danger of burns.

1.9 Tools and consumables

Before starting work ensure that you have suitable tools and /or consumables available. Use only genuine Spirax Sarco replacement parts.

1.10 Protective clothing

Consider whether you and /or others in the vicinity require any protective clothing to protect against the hazards of, for example, chemicals, high/low temperature, radiation, noise, falling objects, and dangers to eyes and face.

1.11 Permits to work

All work must be carried out or be supervised by a suitably competent person. Installation and operating personnel should be trained in the correct use of the product according to the Installation and Maintenance Instructions. Where a formal 'permit to work' system is in force it must be complied with. Where there is no such system, it is recommended that a responsible person should know what work is going on and, where necessary, arrange to have an assistant whose primary responsibility is safety.

Post 'warning notices' if necessary.

1.12 Handling

Manual handling of large and /or heavy products may present a risk of injury. Lifting, pushing, pulling, carrying or supporting a load by bodily force can cause injury particularly to the back. You are advised to assess the risks taking into account the task, the individual, the load and the working environment and use the appropriate handling method depending on the circumstances of the work being done.

1.13 Residual hazards

In normal use the external surface of the product may be very hot. If used at the maximum permitted operating conditions the surface temperature may reach temperatures of 425°C (797°F).

Many products are not self-draining. Take due care when dismantling or removing the product from an installation (refer to 'Maintenance instructions').

1.14 Freezing

Provision must be made to protect products which are not self-draining against frost damage in environments where they may be exposed to temperatures below freezing point.

1.15 Disposal

Unless otherwise stated in the Installation and Maintenance Instructions, this product is recyclable and no ecological hazard is anticipated with its disposal providing due care is taken.

1.16 Returning products

Customers and stockists are reminded that under EC Health, Safety and Environment Law, when returning products to Spirax Sarco they must provide information on any hazards and the precautions to be taken due to contamination residues or mechanical damage which may present a health, safety or environmental risk. This information must be provided in writing including Health and Safety data sheets relating to any substances identified as hazardous or potentially hazardous.

1.17 Safe lifting of Spirax Sarco products

Please note that the Spirax Sarco model FTC80 comes complete with tapped holes located in the cover, which may be used for lifting purposes at the sole risk and responsibility of the purchaser.

The purchaser is responsible for the selection and use of the correct eye-bolt or shackle combination and is, in whole, responsible for all lifting operations and operator competency at their location. Spirax Sarco will ensure that any tapped hole will have a spot face larger than the shoulder of a standard eye-bolt to allow seating down to the shoulder. However, it should not be assumed that an eye-bolt is suitable for lifting the product simply on the basis of shoulder size.

Spirax Sarco will accept no responsibility for loss or damage real or imagined, caused by incorrect or inappropriate lifting of our products.

Spirax Sarco will ensure that the tapped holes provided are clearly marked with the exact size and thread form. We will also carry out in conjunction with a third party, a test on a sample of each product so provided and make available a copy of the test procedure and test certificate on request.

Furthermore and without obligation Spirax Sarco will attach to each product provided with such holes, threaded or otherwise, a disclaimer affixed to the product explaining the purchaser's duty under the LOLER regulations for safe off loading and lifting of the product at their premises.

— 2. General product information —

2.1 Description

As standard, the FTC80 ball float steam trap is supplied with a right to left (R-L) flow configuration having horizontal connections and has provision for adding an air venting option; Please note that the unit is supplied with a 3/4" socket weld connection in the cover with a plug screwed into the fitting. It has been designed for floor mounting and is suitable for most high-pressure process and drainage applications. Its simple robust ball float mechanism ensures excellent resistance to waterhammer. All internals are easily accessible for in-line maintenance and a drain port allows full body drainage. It has a large maintainable strainer screen that extends service intervals and is located in an accessible flanged chamber.

Standard

This product fully complies with the requirements of the European Pressure Equipment Directive 97 / 23 / EC.

Certification

This product is available with certification to EN 10204 3.1 for the body, cover, fasteners, screen flange and BDV2 manual air vent. **Note:** All certification / inspection requirements must be stated at the time of order placement.

Note: For further information see the following Technical Information Sheets: TI-P179-02 for the ASTM body and TI-P179-03 for the EN body.

2.2 Sizes and pipe connections

ASTM body	1½" and 2" ASME (ANSI) B 16.11 Class 6000 socket weld.
	1½" and 2" ASME (ANSI) B 16.5 Class 600 flanges.
EN body	DN40 and DN50 socket weld BS 3799.
	DN40 and DN50 flanged EN 1092 PN100.

Note: Other connections are available upon request but may limit the operating range – Please consult Spirax Sarco for further information.

Drain plug connection is 3/8" screwed BSP or NPT as standard.

2.3 Available options

1. Factory fitted external BDV2 manual air vent having a ½" BSP or NPT screwed connection.

2. Factory fitted internal fixed bleed for continuous discharge of air and other incondensable gases.

Note: As standard the unit is supplied with a 3/4" socket weld connection in the cover with a 3/8" BSP (EN body) or NPT (ASTM body) screwed plug fitted.

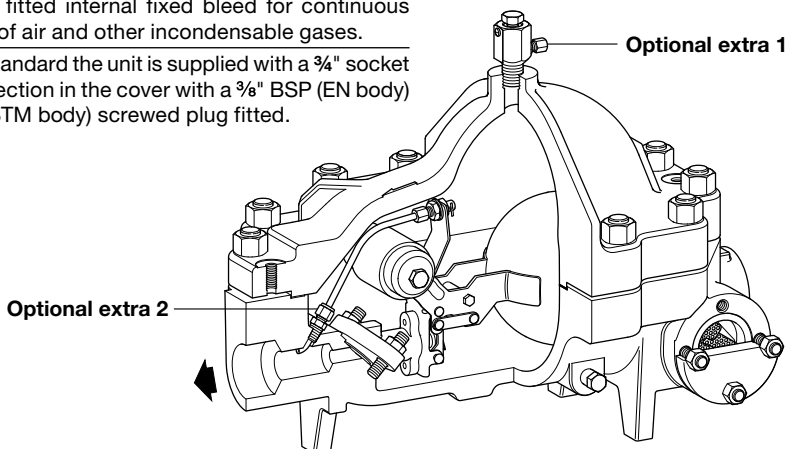
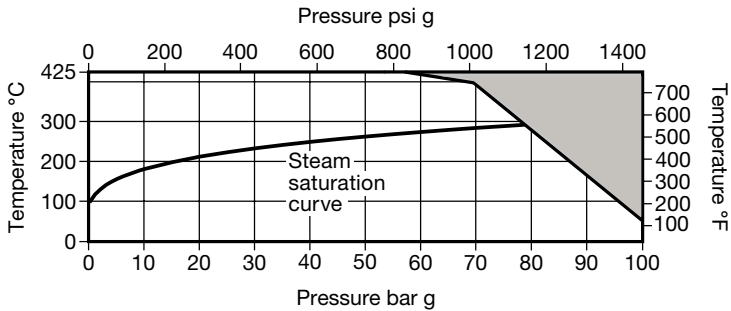

Fig. 1 1½" and 2" FTC80 (R-L) having socket weld connections

2.4 Pressure / temperature limits (ISO 6552)

ASTM body



 The product **must not** be used in this region.

Body design conditions		ASME (ANSI) 600	
PMA	Maximum allowable pressure	100 bar g @ 52°C	(1 450 psi g @ 125.5°F)
TMA	Maximum allowable temperature	425°C @ 57 bar g	(797°F @ 826.5 psi g)
Minimum allowable temperature		-29°C	(-20.2°F)
PMO	Maximum operating pressure for saturated steam service	80 bar g	(1 160 psi g)
TMO	Maximum operating temperature	425°C @ 57 bar g	(797°F @ 826.5 psi g)
Minimum operating temperature		0°C	(32°F)
ΔPMX	Maximum differential pressure	FTC80-45	45 bar (653 psi)
		FTC80-62	62 bar (899 psi)
		FTC80-80	80 bar (1 160 psi)
Designed for a maximum cold hydraulic test pressure:		150 bar g	(2 176 psi g)

EN body

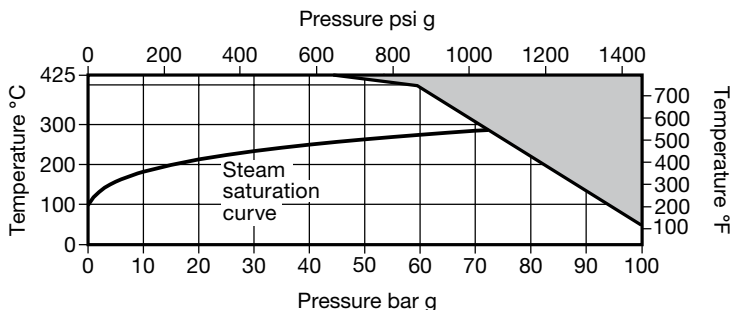

 The product **must not** be used in this region.

Body design conditions		PN100	
PMA	Maximum allowable pressure	100 bar g @ 50°C	(1 450 psi g @ 122°F)
TMA	Maximum allowable temperature	425°C @ 46 bar g	(797°F @ 667 psi g)
Minimum allowable temperature		-29°C	(-20.2°F)
PMO	Maximum operating pressure for saturated steam service	70 bar g	(1 015 psi g)
TMO	Maximum operating temperature	425°C @ 46 bar g	(797°F @ 667 psi g)
Minimum operating temperature		0°C	(32°F)
ΔPMX	Maximum differential pressure	FTC80-45	45 bar (653 psi)
		FTC80-62	62 bar (899 psi)
		FTC80-80	70 bar (1 015 psi)
Designed for a maximum cold hydraulic test pressure		150 bar g	(2 176 psi g)

3. Installation

Notes

Before conducting any maintenance activities observe the 'Safety information' in Section 1.

Referring to the Installation and Maintenance Instructions, name-plate, and Technical Information Sheet, check that the product is suitable for its intended use.

Warnings

The gaskets contained in this product incorporate a thin stainless steel support ring, which may cause physical injury if not handled and disposed of carefully.

The strainer screen is manufactured from sheared perforated sheet which may cause physical injury if not handled and disposed of carefully.

- 3.1** Check materials and maximum pressure / temperature values. If the maximum operating limit of the product is lower than that of the system in which it is being fitted, ensure that a safety device is included in the system to prevent overpressurisation. Suitable isolation valves must be installed to allow for safe maintenance / replacement.
- 3.2** Appropriate high temperature jointing compound must be used on the drain plug and air vent plug threads. Please see Section 6.7 of this document.
- 3.3** Determine the correct installation situation and direction of fluid flow. The flow direction will be clearly marked on the trap cover. A typical installation is shown in Figure 2. Where the trap discharges into a closed return system a non-return valve should be specified downstream.
- 3.4** Remove protection covers from all connections and protective film from all name-plates, where appropriate, before installation on steam or other high temperature applications.
- 3.5** The trap is provided with integral feet for floor mounting or for being supported as such. If for any reason the unit is not floor mounted then any surrounding structures need to be capable of supporting the weight of the trap and the fluid it may contain. Such structures or flooring must be level so that the float arm rises and falls vertically.
- 3.6** The trap should be fitted as close to the outlet of the plant to be drained as possible otherwise the trap can steam lock and this could lead to the system becoming waterlogged. The trap should be fitted below the outlet, with a small drop leg immediately preceding the trap, typically 150 mm (6"). See Figure 2. If no drop leg is allowed for then it may be possible (under low load conditions) for steam to flow over the condensate in the bottom of the pipe and reach the trap.
- 3.7** Where steam traps are fitted in exposed conditions, the possibility of freezing damage may be reduced by thermal insulation, draining and / or isolation. The trap is provided with a drain point, blanked off by a 3/8" hexagon headed plug.
- 3.8** When a socket weld trap is being installed the welding should be carried out to an approved procedure of a recognised standard.
- 3.9** Access and withdrawal distance for removal of the integral strainer screen and cover should be provided.
- 3.10** Access to the cover bolts should receive due consideration as the recommended torque value will require the use of a large torque wrench or torque multiplier / gear headed wrench.

Note: If the trap is to discharge to atmosphere, ensure that it is to a safe place. The discharging fluid may generate high noise levels and be at a temperature of 100°C (212°F).

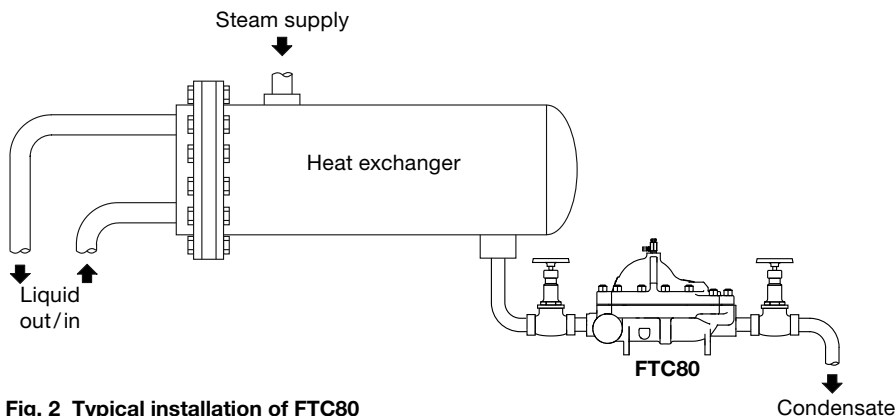

Fig. 2 Typical installation of FTC80

4. Commissioning

Commissioning with particular reference to venting air

It can take several hours or even days to bring a new system to normal operating pressure and temperature. Even if the trap has replaced another one, while the main system has remained running, it may still be necessary to vent air from the drop leg. If the trap is some distance from the upstream isolation valve it could be possible to air lock the pipework between the valve and the trap (i.e. the trap closes to air and does not readily allow steam to enter the pipework). To overcome this on start-up, as an option, the trap can be supplied either with an external operated air vent (BDV2) or with an internal fixed bleed. As standard the air vent hole is supplied with a plug fitted allowing the user to determine the method of air venting.

To commission a new or replacement installation first read the advice given in Section 5.2 on how to operate the air vent and clear an air locked trap, then proceed as follows. If an internal fixed bleed is present then manual air venting is not required. Ensure that the upstream isolation valve is closed before opening the air vent as documented in Section 5.2. With the air vent now open, slowly open the upstream valve. Note that in order to vent air from the drop leg and trap the isolation valve does not need to be opened fully. Air, steam and/or condensate will now be vented from the top of the trap. Once the air has been fully discharged close and tighten the air vent to the recommended torque (see Table 1, page 20). Once the air vent is closed the upstream valve may be slowly opened fully and the trap will begin to function normally.

After installation or maintenance always open isolation valves slowly to mitigate system shocks and check for leaks. Ensure that the system is fully functional and carry out tests on any alarms or protective devices.

The trap can be cold hydraulic tested, up to and including 150 bar g (2176 psi g) without the need to remove any internals. At pressures beyond this limit, permanent damage may occur to the float that would render the trap inoperative.

Note: After the trap has been in service at normal operating pressure and temperature for 24 hours, it is essential that the cover bolts be retightened (see Figure 5, page 13). This will ensure the correct compression of the gasket under service conditions.

5. Operation

5.1 General information

The ball float steam trap is a continuous discharge device, removing condensate the instant it forms. On start-up the external air vent or internal fixed bleed allows air to bypass the main valve preventing the system from air binding. When condensate arrives at the trap in sufficient quantity to cause the water level to rise, it generates buoyancy in the float which in turn actuates the lever mechanism and opens the main valve, keeping the system drained of condensate at all times. When the condensate level falls the float drops. This causes the main valve to close before live steam can reach it. The mechanism is balanced to retain a constant water level above the main valve at all times (unless the trap is drained or bypassed). This constant water seal is what prevents the loss of live steam. Float traps are renowned for their high start-up load handling capability, clean tight shut-off and resistance to both waterhammer and vibration. **Note:** When the fixed bleed is fitted there will be a continuous discharge of air and other incondensable gases, not just during start-up.

5.2 Air binding and steam locking

Traps can steam lock or air bind and fail closed. In both cases a gas or vapour is preventing condensate from reaching the trap with the result that the float is no longer buoyant and the trap closes. In some cases the steam may condense (and the trap open) but trapped air has no means of escape and the trap will be permanently disabled. To mitigate this problem, either an external manually operated air vent BDV2 (12) can be provided at the top of the cover for the rapid removal of air or incondensable gases. As an option, an air vent can be fitted or internal fixed bleed. The trap with the BDV2 may be vented by turning the bleed screw anticlockwise taking adequate measures (including thermal insulating gloves, safety glasses and a long handled spanner) to protect the operator from any hot discharge. The A/F dimension of the bleed screw is 17 mm and torque figures are provided in Table 1, page 20. During actuation of the bleed screw and/or while the trap is pressurised, the main body (12) of the BDV2 manual air vent (with a A/F dimension of 24 mm) should not be loosened. The bleed screw is principally provided as a manually operated air vent for use during start-up however, it could also be used to relieve steam locking. The manually operated air vent (12) has not been designed to be used as a permanent vent and should be closed tight once the blockage has been removed. To close the bleed screw, turn it clockwise. Further venting may be required if residual air in the system finds its way to the trap in sufficient quantity to prevent the float from being immersed in condensate or, on start-up after a prolonged period of shutdown. If an internal fixed bleed is present then manual air venting is not required.

Fig. 3 Manually operated air vent (BDV2)

Note: The bleed screw needs to be turned only by one half turn to one whole turn for the air vent to work. (Please see IM-P600-02).

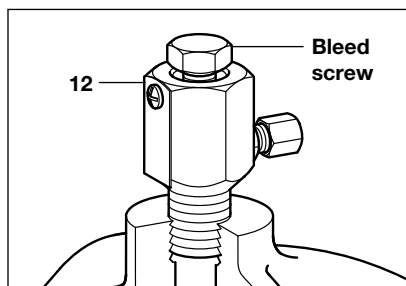

5.3 Correct sizing

It is important that the FTC80 is correctly sized to the running load of the plant being drained. See the following Technical Information Sheets for full details on capacities: TI-P179-02 for the ASTM body or TI-P179-03 for the EN body. If the trap is undersized then it will still attempt to operate correctly however condensate will back up. This could lead to a drop in plant efficiency, a greater risk of waterhammer, and failure of the trap to open if the increase in head exceeds the differential pressure of the mechanism.

5.4 How to size the condensate return line

Where high volumes of flash steam are involved, it is important to select the correct pipework downstream of a steam trap.

Incorrectly sized pipework will lead to rapid erosion of the pipework and / or product and may also generate excessive backpressure on the trap. Clearly DN40 and DN50 (1½" and 2") FTC80's condensate discharge line will need to be significantly larger than 40 mm or 50 mm when high pressures and high flowrates are involved.

The section of pipeline downstream of the steam trap will carry both condensate and flash steam at the same pressure and temperature. This is referred to as two-phase flow, and the mixture of liquid and vapor will have the characteristics of both steam and water in proportion to how much of each is present.

The two-phase fluid in the trap discharge line will have much more in common with steam than water, and it is sensible to size on reasonable steam velocities rather than use the relatively small volume of condensate as the basis for calculation. If lines are undersized, the flash steam velocity and backpressure will increase, which can cause waterhammer, reduce the trap capacity, and flood the process.

Steam lines are sized with attention to maximum velocities.

For further information refer to:

- Module 14.3 of the Steam and Condensate Loop Book (SC-GCM-01).

alternatively:

- www.spiraxsarco.com/resources/steam-engineering-tutorials/condensate-recovery/sizing-condensate-return-lines.asp

5.5 Waterhammer

Waterhammer is an impact load caused by starting and / or stopping liquid flow suddenly. Due to the immense impulse pressures generated, the results of waterhammer can be devastating. Permanent deformation or even catastrophic failure could occur to the pressure containing shell in such situations. The risk of damage from waterhammer can be mitigated by correct plant design and the slow opening or closing of isolation valves.

6. Maintenance

Note

Before conducting any maintenance activities observe the 'Safety information' in Section 1.

Warnings

The gaskets contained in this product incorporate a thin stainless steel support ring, which may cause physical injury if not handled and disposed of carefully.

The strainer screen is manufactured from sheared perforated sheet which may cause physical injury if not handled and disposed of carefully.

6.1 General information

With suitable isolation, maintenance or repairs can be completed with the trap in the pipeline once the safety procedures have been observed. In particular, prior to any maintenance ensure that the trap is isolated, that no pressure exists within the unit and that components can be handled without the risk of causing burns, either by allowing the trap time to cool or by wearing thermal insulating gloves. It is recommended that new gaskets and spares are used whenever maintenance is undertaken and that when reassembling, all joint faces are clean. Ensure that the correct tools and necessary protective equipment are used at all times and recommended torque values documented in Table 1 (page 20) are adhered to. When maintenance is complete open isolation valves slowly and check for leaks.

6.2 Recommended service intervals

If installed and maintained in accordance with these instructions the trap will give many years of trouble free operation. However, it is recommended that the trap receives an annual inspection to give early warning of any potential issues and save the plant from unscheduled interruptions.

6.3 How to access, replace or clean the strainer screen

The strainer screen (8) is located on the inlet side of the trap and is housed in a pocket which is covered by a circular strainer flange (7) and retained by 4 off strainer nuts (11).

- Ensure the trap is depressurised (see 'Section 6.1 - General information')
- Unscrew the 4 off strainer nuts (11), lift off the strainer flange (7) and remove the strainer gasket (9).
- Withdraw the strainer screen (8) by pulling it out of its pocket wearing suitable gloves to guard against physical injury.
- Clean the strainer screen (8) or replace it, as required.
- Fit the cleaned or new strainer screen (8) by pushing it back into the trap, with the opening in the screen toward the inlet.
- Clean both gasket faces, fit a new strainer gasket (9), fit the strainer flange (7) and tighten the 4 strainer nuts (11) to the recommended tightening torque (see Figure 5, page 13). The recommended bolting sequence and procedure is also given in Figure 5.

Fig. 4 Strainer screen

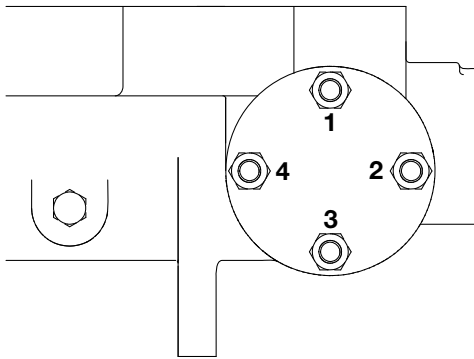
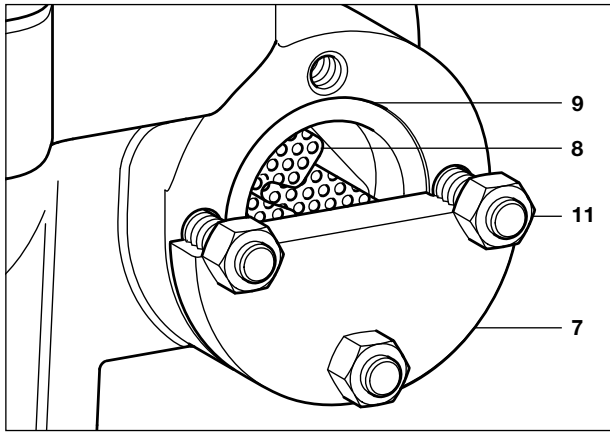

- A.** Install bolts hand tight then "snug-up" to 15 N m to 30 N m but not to exceed 20% of the target torque. Check flange gap for uniformity.
- B.** Tighten to 20% to 30% of target torque. Check flange gap for uniformity.
- C.** Tighten to 50% to 70% of target torque. Check flange gap for uniformity.
- D.** Tighten to 100% of target torque. Check flange gap for uniformity.
- E.** Continue to tighten the bolts on a rotational clockwise pattern until no further rotation occurs at the target torque.

Sequence	Recommend target torque for strainer flange	
	N m	lbf ft
A	10 - 16	7 - 12
B	16 - 24	12 - 18
C	40 - 56	29 - 41
D	80	59
E	80	59

Fig. 5 Recommended bolting sequence (1-3-2-4) and torque

6.4 How to access the mechanism assembly

To gain access to the mechanism assembly (13) the cover (2) needs to be removed. For this, and any servicing, the trap may remain in the pipeline.

- Ensure the trap is depressurised (see 'Section 6.1 - General information')
- Unscrew the 14 cover nuts (5) and remove the cover (2) and cover gasket (3). The cover (2) weighs in the region of 35 kg (77 lb) and threaded connections are provided (one at each end) for the use of M12 lifting eyes. Place the cover (2) down in such a manner as not to damage the gasket face.
- The mechanism assembly (13) will now be clearly visible. It is retained to the body by 2 off M12 assembly studs and nuts (18a and 18b), Figure 7. These are located at the opposite end to the float (14). Unscrew the 2 assembly nuts (18b) and remove the mechanism assembly (13) and assembly gasket (19).

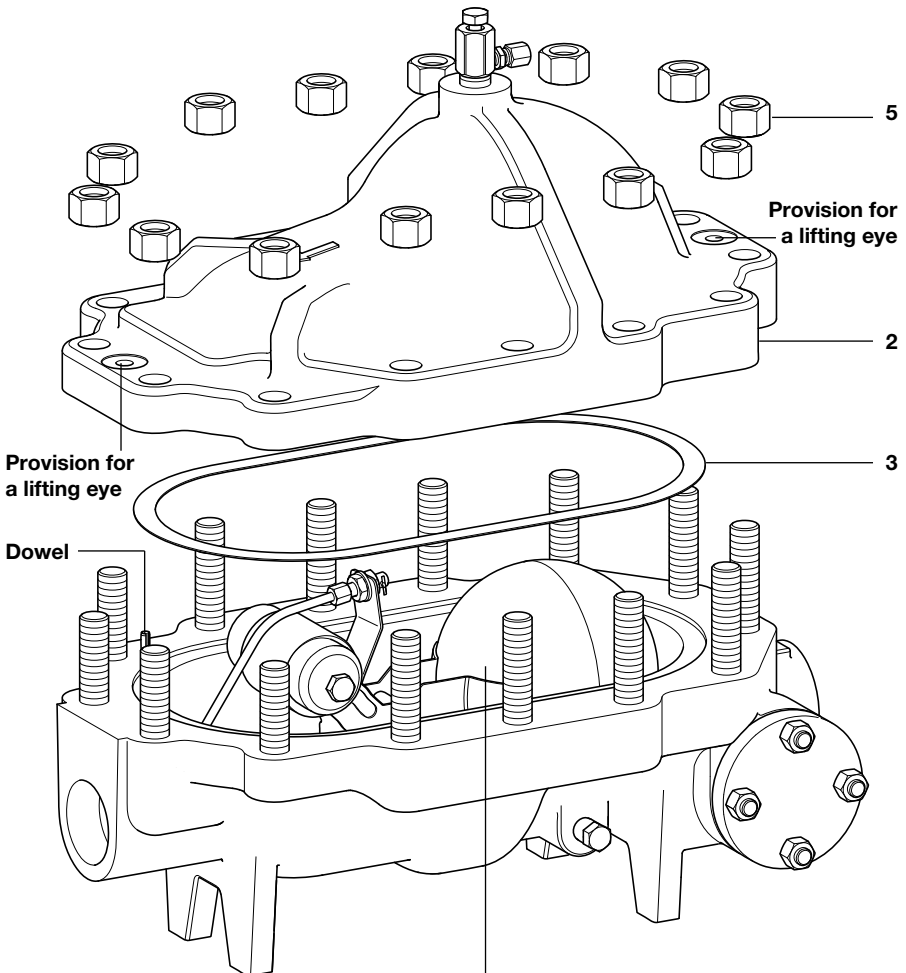

Fig. 6 Cover removal

13 and 14

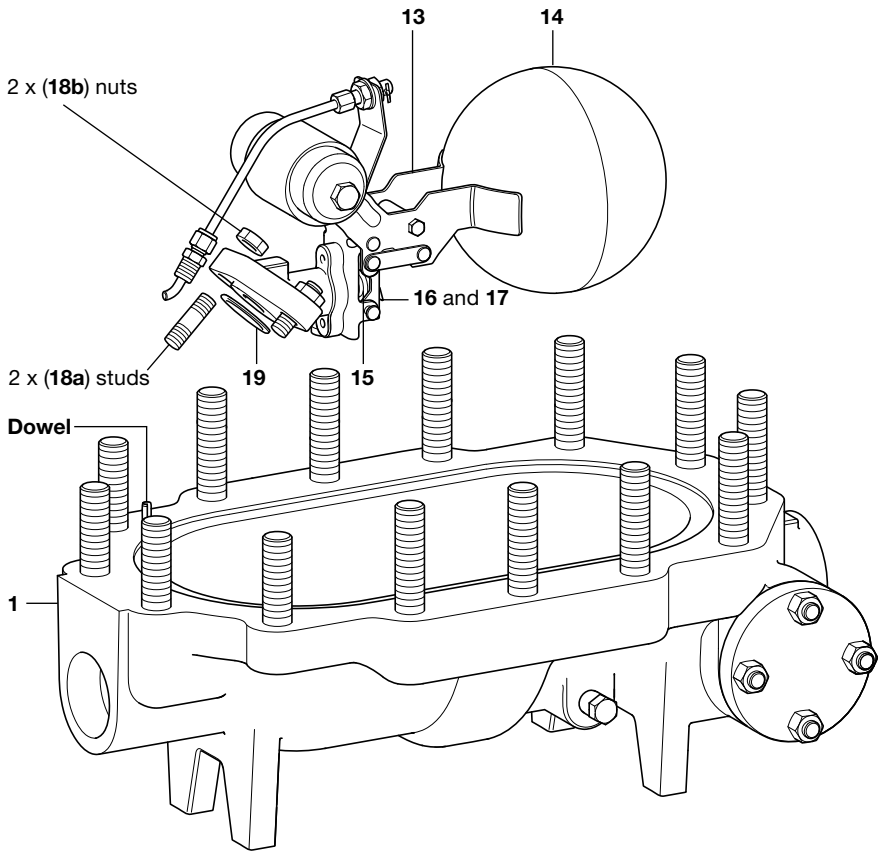
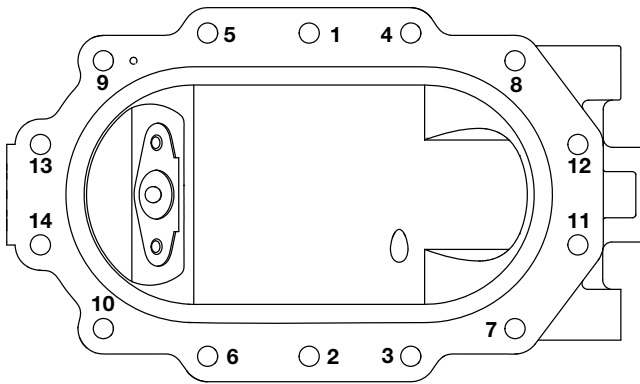
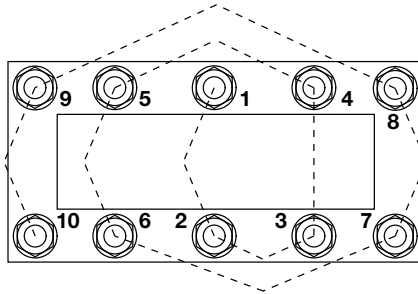

Fig. 7 Mechansim assembly removal

- The mechanism assembly (13) can now be worked upon remotely from the body (1) allowing good access to such features as the seat (15), the ball head (16), retainer (17) and the float mechanism assembly (13 and 14).
- To refit the mechanism assembly (13) back into the body (1) locate on to the two M12 assembly studs (18a) and evenly tighten the 2 off M12 assembly nuts (18b) to the recommended torque (see Table 1, page 20) having remembered to fit a new assembly gasket (19) to the cleaned gasket faces.
- Clean the gasket faces on the body (1) and the cover (2), fit a new cover gasket (3), reposition the cover (2) and tighten the 14 off cover nuts (5) to the recommended torque (see Figure 8) to reassemble the trap. The four shorter bolts should be fitted at the outlet end of the trap where the cover flange is thinnest. A dowel in the body (1) ensures that the cover (2) can only be assembled to the body (1) the correct way round.

Spiral tightening sequence starting in the middle for non-circular bolt patterns



- A.** Install bolts hand tight then "snug-up" to 15 N m to 30 N m but not to exceed 20% of the target torque. Check flange gap for uniformity.
- B.** Tighten to 20% to 30% of target torque. Check flange gap for uniformity.
- C.** Tighten to 50% to 70% of target torque. Check flange gap for uniformity.
- D.** Tighten to 100% of target torque. Check flange gap for uniformity.
- E.** Continue to tighten the bolts on a rotational clockwise pattern until no further rotation occurs at the target torque.

Sequence	Recommend target torque for studs and cover nuts	
	N m	lbf ft
A	45 - 85	33 - 63
B	85 - 127	63 - 94
C	121 - 298	89 - 220
D	425	313
E	425	313

Fig. 8 Recommended bolting sequence (1-2-3-4-5-6-7-8-9-10-11-12-13-14) and torque

6.5 Servicing the mechanism assembly (Mechanism seat (15) and ball head (16))

- Ensure the trap is depressurised (see 'Section 6.1 - General information').
- Follow the instructions under Section 6.4 to access and remove the mechanism assembly (13 and 14).
- Once removed, the mechanism assembly (13) is easily disassembled by removing each spring clip (20) at the end of each pivot pin (21). The pins may then be withdrawn.
- The valve seat (15) and ball head (16) can now be accessed and replaced if necessary.
- To replace the seat (15) unscrew the old one from the mounting bracket (22). Tighten the new seat (15) to the recommended torque (see Table 1, page 20). There is no need to remove the pressed steel pivot frame during this operation.
- To replace the ball head (16) simply remove the retainer (17). The old ball head (16) should drop out of its frame. Fit the new ball head (16) through the pivot frame and refit the retainer (17). Ensure that the ball head (16) and the tabs on the frame are on the same side as one another. The retainer (17) should be on the opposite side to the tabs on the pivot frame (as shown in Figure 9).
- Reassemble the mechanism assembly (13) as shown using the pivot pins (21) and spring clips (20). Refit the mechanism assembly as instructed under Section 6.4.

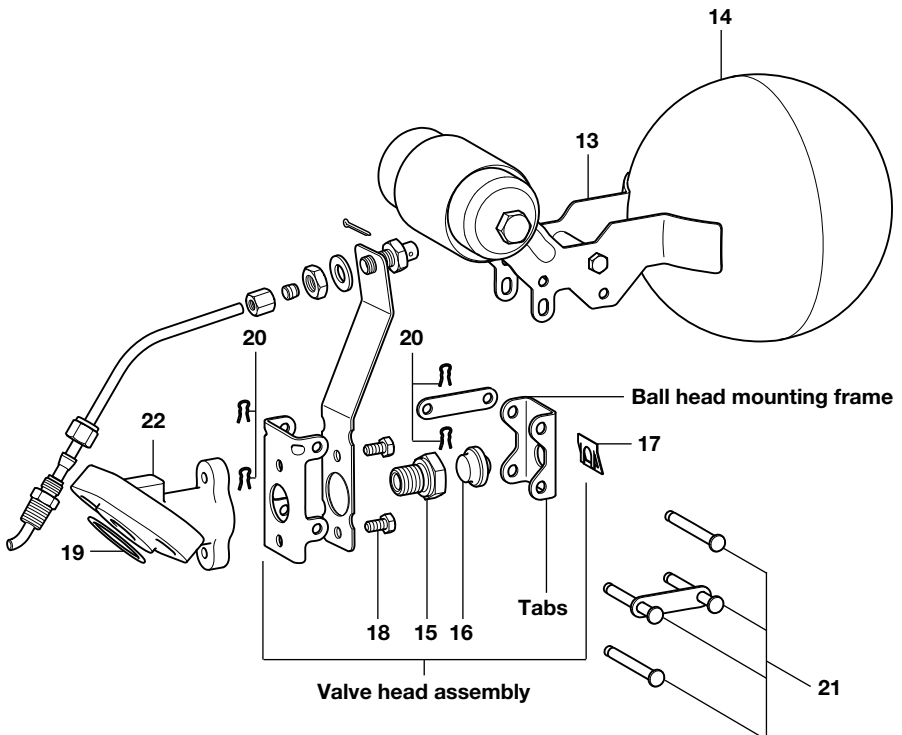

Fig. 9 Seat and ball head replacement

6.6 How to replace the fixed bleed and mechanism assembly

To gain access to the mechanism assembly (13) the cover (2) needs to be removed. For this, and any servicing, the trap may remain in the pipeline.

- Ensure the trap is depressurised (see 'Section 6.1 - General information').
- Unscrew the 14 off cover nuts (5) and remove the cover (2) and cover gasket (3). The cover (2) weighs in the region of 35 kg (77 lb) and threaded connections are provided (one at each end) for the use of M12 lifting eyes on the PN100 flanged traps and ½" UNC on socket weld and class 600 flanged traps. Place the cover (2) down in such a manner as not to damage the gasket face.
- The mechanism and fixed bleed assembly (13 and 32) will now be clearly visible. The mechanism assembly (13) is retained to the body by 2 off M12 assembly studs (18a) and nuts (18b). These are located at the opposite end to the float (14). It is also connected to the fixed bleed assembly via the pipe support (34).
- Remove the fixed bleed assembly by unscrewing nut (37) to release the compression fitting joint. Unscrew stud (40) and remove fixed bleed pipe (39) from the body (1).
- Unscrew the two assembly nuts (18b) and remove the mechanism assembly (13) and assembly gasket (19).
- To fit a new mechanism assembly (13) into the body (1) locate on to the two M12 assembly studs (18a) and evenly tighten the 2 off M12 assembly nuts (18b) to the recommended torque (see Table 1, page 20) having remembered to fit a new assembly gasket (19) to the cleaned gasket faces.
- Fit the new bleed pipe (39) to the body (1) by tightening the stud (40) (see the note at the bottom of page 20). Use a suitable joining compound on the stud (40) thread (see page 20). Do not tighten the nut (42) at this stage. Pass the nut (37), then the ferrule (38) over the end of the bleed pipe. The ferrule (38) must be located on to the pipe in the correct orientation by firstly passing the larger diameter end over the end of the pipe.
- Locate the end of the bleed pipe (39) into the bleed orifice (33).
- To affect a steam tight seal at the compression fittings tighten nut (42) and then nut (37). To ensure the downstream outlet of the bleed pipe (39) is in the correct position the pipe should be gently pulled up through the stud (40) as far as it will travel before tightening the nut (42) - See Figure 8, page 16.
- Clean the gasket faces on the body (1) and the cover (2), fit a new cover gasket (3), reposition the cover (2) and tighten the 14 off cover nuts (5) to the recommended torque (see Figure 8, page 16) to reassemble the trap. The four shorter bolts should be fitted at the outlet end of the trap where the cover flange is thinnest. A dowel in the body (1) ensures that the cover (2) can only be assembled to the body (1) the correct way round.

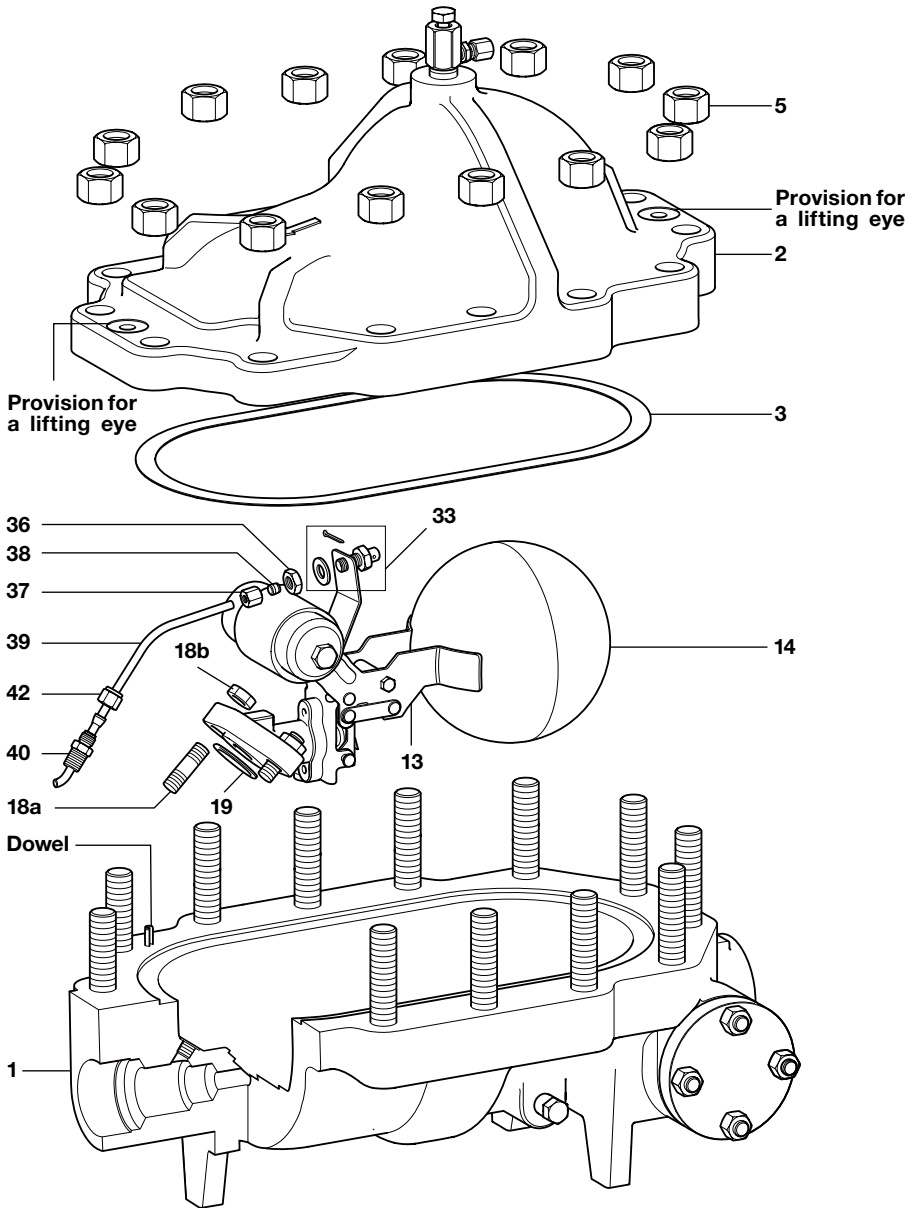

Fig. 10 Replacement fixed and mechanism assembly

6.7 How to replace the manually operated air vent BDV2

- Turn the bleed screw anticlockwise by one half or one whole turn to check that the trap is depressurised.
- Unscrew the air vent plug (12) and remove it from the trap.
- Tighten the new BDV2 air vent (12) to the recommended torque (see Table 1).

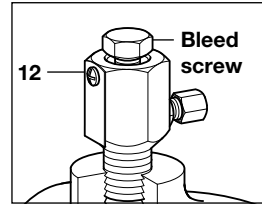



Fig. 11

Table 1 Recommended tightening torques - see Figure 12

Item	Part		or mm		Torque	
					N m	lbf ft
5	Cover nuts	30 A/F		M20	425	314
11	Strainer nuts	19 A/F		M12	80	59
12	Body	24 A/F		½" BSP or NPT	See note below	
Air vent	Bleed screw	17 A/F		M12	22 – 25	17 - 19
15	Valve seat	24 A/F		M16	60	45
18b	Assembly nuts	19 A/F		M12	80	60
27	Drain plug	22 A/F		½" BSP or NPT	See note below	

Joining compound on threads

A high temperature manganese thread jointing compound is applied to the FTC80 threads on the drain plug (as standard) air vent connection (if screwed connection is required) and fixed bleed stud (if requested). The jointing compound can be used in the temperature range of -20°C to 600°C (-4°F to 1112°F) and of a pressure up to 193 bar g (2 799 psi g). Following application, the jointing compound must be allowed to cure for 5 minutes before assembly and 24 hours before testing. It is resistant to high temperatures and pressures. It also resists vibration and thermal expansion. Hemp may be used as reinforcement, this must be fully wetted with the compound prior to assembly of the joint. It is suitable for use with high pressure steam, non potable water, compressed air, LPG, natural gas and alcohol, but it is not suitable for oils or petroleum products.

How jointing compounds are applied

Prior to applying the jointing compound, it is most important that both the male and female threads are clean i.e. all traces of cutting fluid, rust, paint, grease and any other contaminant is removed. If a joint is being remade then all traces of previous jointing compound etc must be removed before applying fresh material.

Under normal pipe fitting practice, jointing compound is applied to the male thread and is usually reinforced with a small quantity of hemp. Any excess compound which extrudes around the joint when it has been assembled should be wiped clean.

Note: The recommended procedure for tightening taper threads is to screw the connection until it is hand tight and then proceed to screw the component another 2 to 3 complete turns to effect a seal.

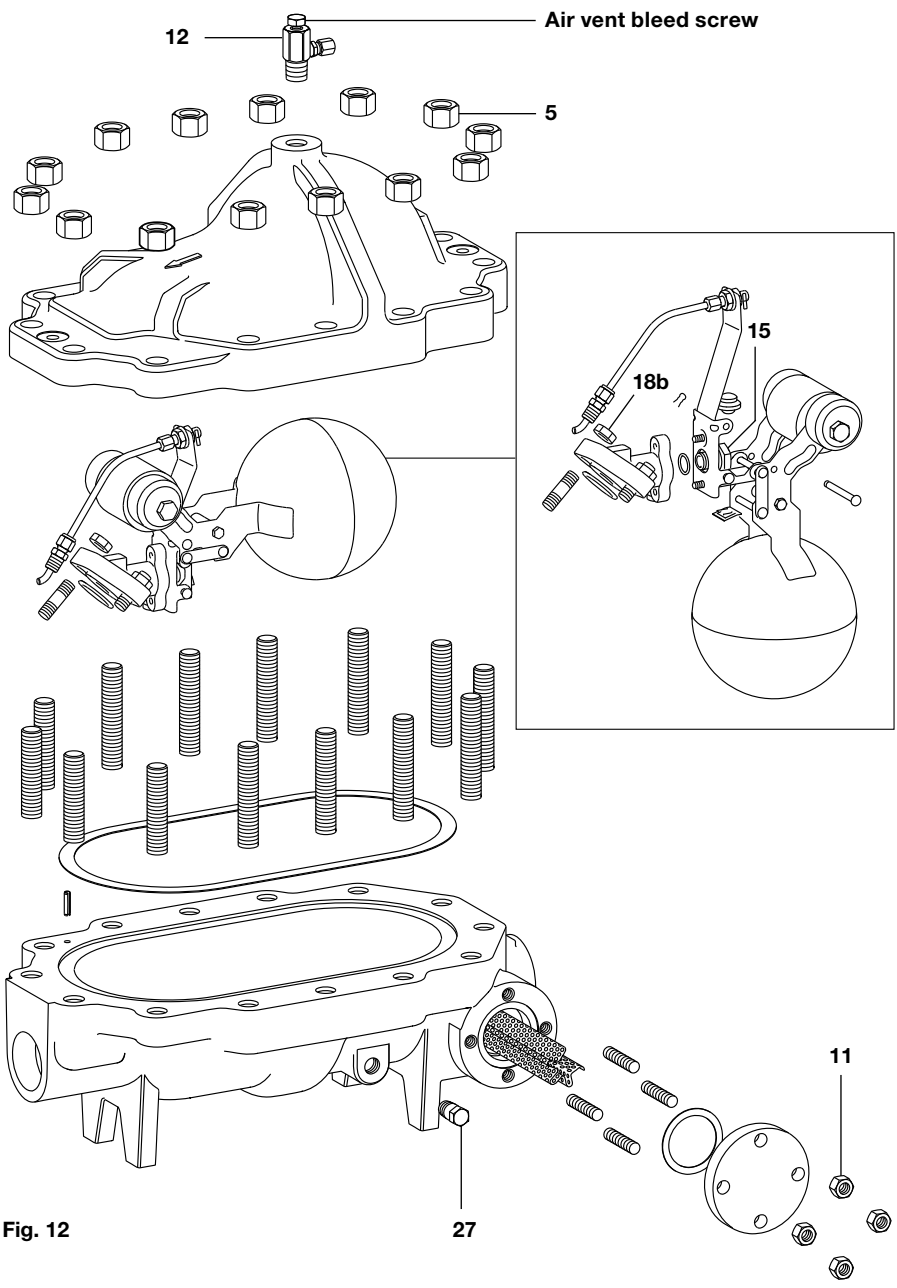

Fig. 12

7. Spare parts

The spare parts available are shown in solid outline. Parts shown in broken line are not supplied as spares. Spares do not come packaged with cover gasket (3). In order to offer the maximum flexibility in choice, cover gasket (3) needs to be ordered separately.

Available spares

Mechanism maintenance kit including float	3, 13, 18a, 18b, 19
Seat and ball head	3, 15, 16, 17, 19, 26
Cover gasket (3 off)	3
Strainer screen	8, 9
Strainer gasket (3 off)	9
Mechanism and fixed bleed maintenance kit including float.	3, 13, 18a, 18b, 19, 32

How to order spares

Always order spares by using the description given in the column headed 'Available spares' and state the size and type of trap, including pressure range.

How to order example: 1 off Seat and ball head set for a Spirax Sarco DN40 FTC80-45 ball float steam trap.

Item 12 The BDV2 air vent is an optional extra.
 For ordering this unit see
 TI-P600-01.

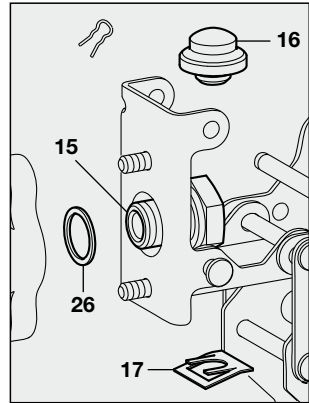
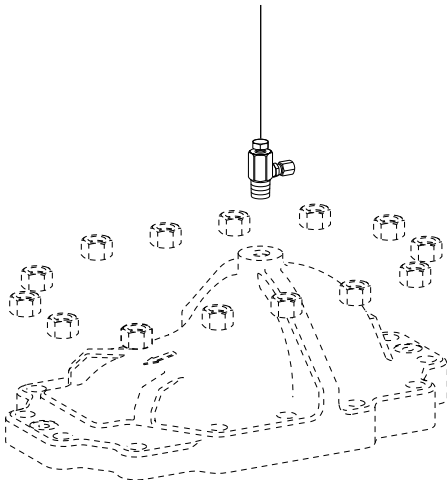

32
 (Optional - fixed
 bleed assembly)

