

FT14 and FT14HC
1"HC, 1¼", 1½" and 2" Ball Float Steam Traps
Installation and Maintenance Instructions**FT14HC 1"**
FT14 1¼"**FT14**
1½" and 2"

1. Safety information
2. General product information
3. Installation
4. Commissioning
5. Operation
6. Maintenance
7. Spare parts

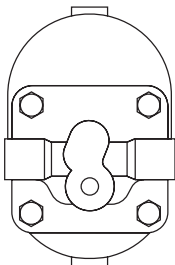
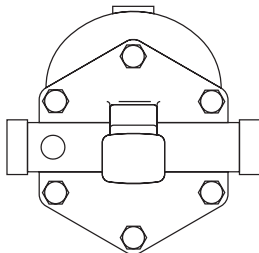

1. Safety information

Safe operation of these products can only be guaranteed if they are properly installed, commissioned, used and maintained by qualified personnel (see Section 1.11) in compliance with the operating instructions. General installation and safety instructions for pipeline and plant construction, as well as the proper use of tools and safety equipment must also be complied with.

1.1 Intended use

Referring to the Installation and Maintenance Instructions, name-plate and Technical Information Sheet, check that the product is suitable for the intended use/application. The products listed below comply with the requirements of the European Pressure Equipment Directive 97/23/EC and carry the CE mark when so required. The products fall within the following Pressure Equipment Directive categories:

	Product	Group 2 Gases	Group 2 Liquids
FT14 and FT14HC	1"HC, 1¼" and 1½"	SEP	SEP
	2"	1	SEP

- i) The products have been specifically designed for use on steam, air or water/condensate which are in Group 2 of the above mentioned Pressure Equipment Directive. The products' use on other fluids may be possible but, if this is contemplated, Spirax Sarco should be contacted to confirm the suitability of the product for the application being considered.
- ii) Check material suitability, pressure and temperature and their maximum and minimum values. If the maximum operating limits of the product are lower than those of the system in which it is being fitted, or if malfunction of the product could result in a dangerous overpressure or overtemperature occurrence, ensure a safety device is included in the system to prevent such over-limit situations.
- iii) Determine the correct installation situation and direction of fluid flow.
- iv) Spirax Sarco products are not intended to withstand external stresses that may be induced by any system to which they are fitted. It is the responsibility of the installer to consider these stresses and take adequate precautions to minimise them.
- v) Remove protection covers from all connections and protective film from all name-plates, where appropriate, before installation on steam or other high temperature applications.

1.2 Access

Ensure safe access and if necessary a safe working platform (suitably guarded) before attempting to work on the product. Arrange suitable lifting gear if required.

1.3 Lighting

Ensure adequate lighting, particularly where detailed or intricate work is required.

1.4 Hazardous liquids or gases in the pipeline

Consider what is in the pipeline or what may have been in the pipeline at some previous time. Consider: flammable materials, substances hazardous to health, extremes of temperature.

1.5 Hazardous environment around the product

Consider: explosion risk areas, lack of oxygen (e.g. tanks, pits), dangerous gases, extremes of temperature, hot surfaces, fire hazard (e.g. during welding), excessive noise, moving machinery.

1.6 The system

Consider the effect on the complete system of the work proposed. Will any proposed action (e.g. closing isolation valves, electrical isolation) put any other part of the system or any personnel at risk?

Dangers might include isolation of vents or protective devices or the rendering ineffective of controls or alarms. Ensure isolation valves are turned on and off in a gradual way to avoid system shocks.

1.7 Pressure systems

Ensure that any pressure is isolated and safely vented to atmospheric pressure. Consider double isolation (double block and bleed) and the locking or labelling of closed valves. Do not assume that the system has depressurised even when the pressure gauge indicates zero.

1.8 Temperature

Allow time for temperature to normalise after isolation to avoid danger of burns.

1.9 Tools and consumables

Before starting work ensure that you have suitable tools and/or consumables available. Use only genuine Spirax Sarco replacement parts.

1.10 Protective clothing

Consider whether you and/or others in the vicinity require any protective clothing to protect against the hazards of, for example, chemicals, high/low temperature, radiation, noise, falling objects, and dangers to eyes and face.

1.11 Permits to work

All work must be carried out or be supervised by a suitably competent person. Installation and operating personnel should be trained in the correct use of the product according to the Installation and Maintenance Instructions.

Where a formal 'permit to work' system is in force it must be complied with. Where there is no such system, it is recommended that a responsible person should know what work is going on and, where necessary, arrange to have an assistant whose primary responsibility is safety.

Post 'warning notices' if necessary.

1.12 Handling

Manual handling of large and/or heavy products may present a risk of injury. Lifting, pushing, pulling, carrying or supporting a load by bodily force can cause injury particularly to the back. You are advised to assess the risks taking into account the task, the individual, the load and the working environment and use the appropriate handling method depending on the circumstances of the work being done.

1.13 Residual hazards

In normal use the external surface of the product may be very hot. If used at the maximum permitted operating conditions the surface temperature of some products may reach temperatures in excess of 250°C (482°F).

Many products are not self-draining. Take due care when dismantling or removing the product from an installation (refer to 'Maintenance instructions').

1.14 Freezing

Provision must be made to protect products which are not self-draining against frost damage in environments where they may be exposed to temperatures below freezing point.

1.15 Disposal

Unless otherwise stated in the Installation and Maintenance Instructions, this product is recyclable and no ecological hazard is anticipated with its disposal providing due care is taken.

1.16 Returning products

Customers and stockists are reminded that under EC Health, Safety and Environment Law, when returning products to Spirax Sarco they must provide information on any hazards and the precautions to be taken due to contamination residues or mechanical damage which may present a health, safety or environmental risk. This information must be provided in writing including Health and Safety data sheets relating to any substances identified as hazardous or potentially hazardous.

1.17 Working safely with cast iron products on steam

Cast iron products are commonly found on steam and condensate systems. If installed correctly using good steam engineering practices, it is perfectly safe. However, because of its mechanical properties, it is less forgiving compared to other materials such as SG iron or carbon steel. The following are the good engineering practices required to prevent waterhammer and ensure safe working conditions on a steam system.

Safe Handling

Cast Iron is a brittle material. If the product is dropped during installation and there is any risk of damage the product should not be used unless it is fully inspected and pressure tested by the manufacturer.

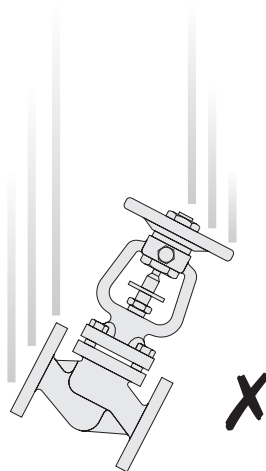

Prevention of water hammer

Steam trapping
on steam mains:

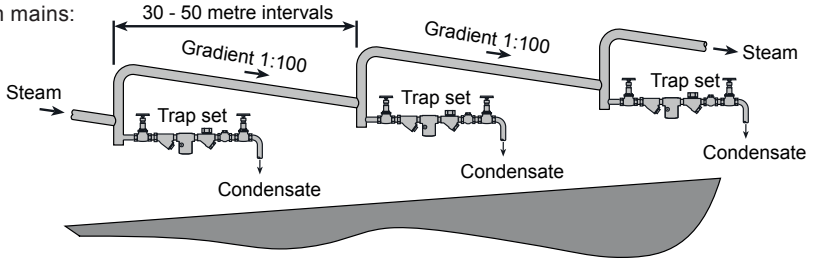

Steam Mains - Do's and Don'ts:

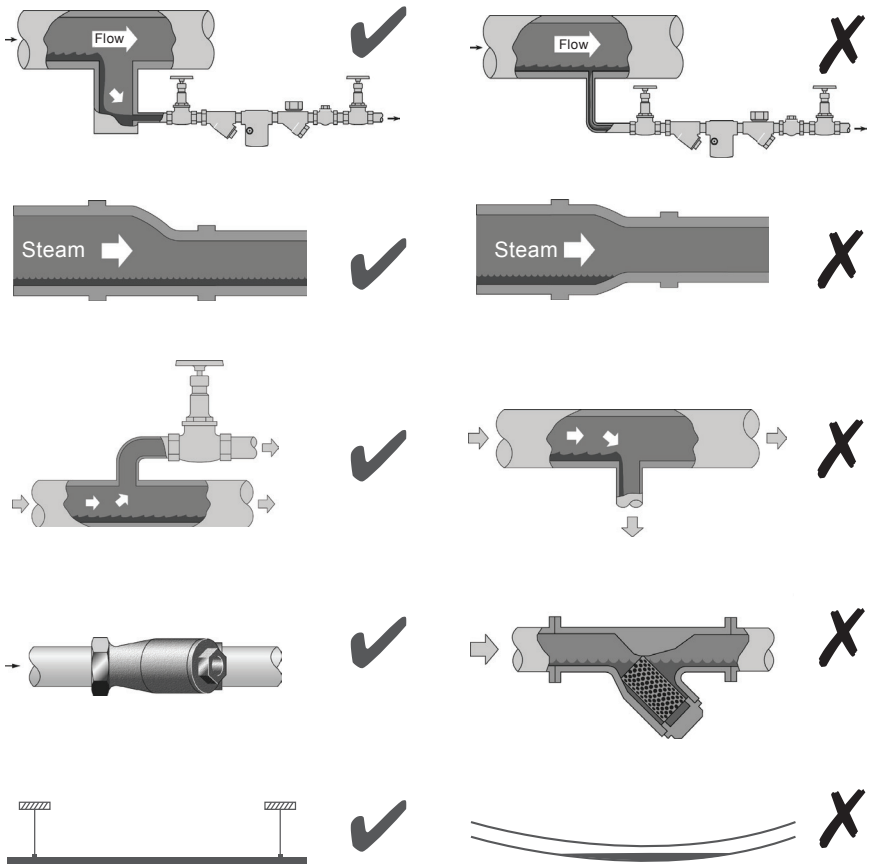

Prevention of tensile stressing

Pipe misalignment:

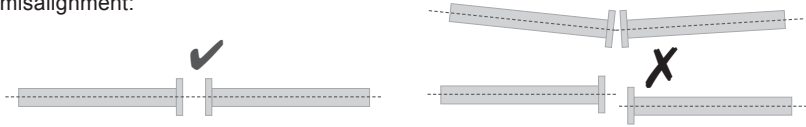

Installing products or re-assembling after maintenance:



Do not over tighten.
Use correct torque figures.

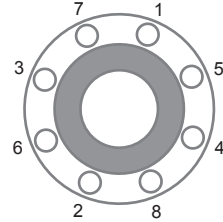
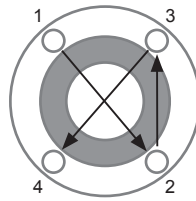

Flange bolts should be gradually tightened across diameters to ensure even load and alignment.

Thermal expansion:

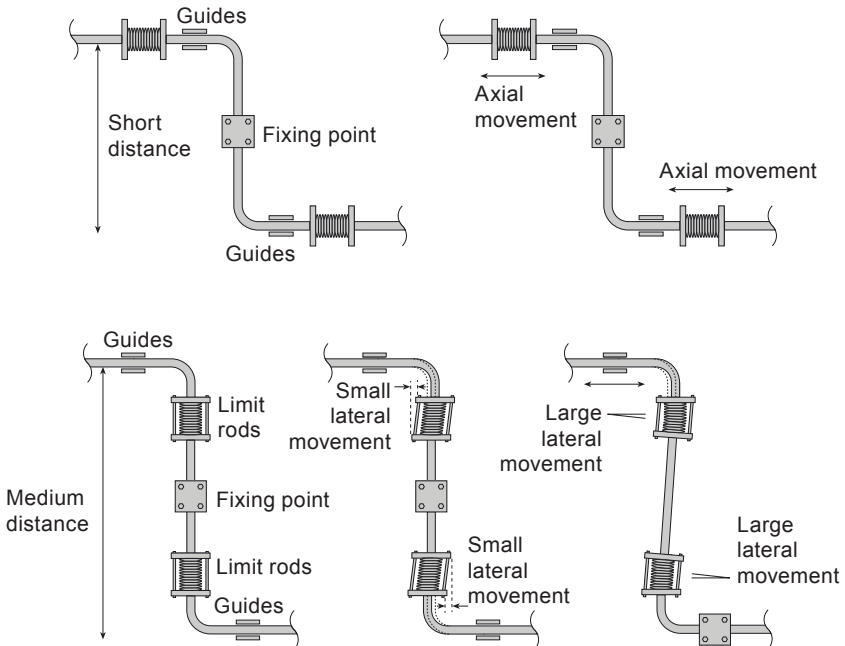

— 2. General product information —

2.1 General description

The FT14 and FT14HC are iron bodied ball float steam traps having stainless steel working internals and integral automatic air venting facility. These traps are supplied with horizontal screwed connections and can be maintained without disturbing the pipework. The flow direction is as indicated on the valve body – see Figure 1.

Capsule

The BP99/32 capsule which is used in both the FT14 and FT14HC is suitable for use on 150°C superheat @ 0 bar g and 50°C superheat @ 32 bar g.

Optional extras

A **manually adjustable needle valve** (designated 'C' on the nomenclature i.e. **FT14-C**) can be fitted to the trap. This option provides a **steam lock release (SLR)** feature in addition to the standard air vent. For further information please consult Spirax Sarco.

The **top of the cover can be drilled and tapped 3/8" BSP or NPT** for the purpose of fitting a balance line if requested at the point of order.

The **bottom of the cover can be drilled and tapped 3/8" BSP or NPT** for the purpose of fitting a drain cock if requested at the point of order.

Standards

These products fully comply with the requirements of the European Pressure Equipment Directive 97/23/EC.

Certification

The product is available with a manufacturers' Typical Test Report. **Note:** All certification/inspection requirements must be stated at the time of order placement.

Note: For further information see the following Technical Information sheets: TI-S02-27 and TI-S02-28.

2.2 Sizes and pipe connections

1" (FT14HC only), 1¼", 1½" and 2" screwed BSP and NPT.

FT14HC 1" and FT14 1¼"

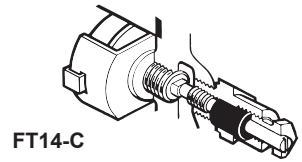
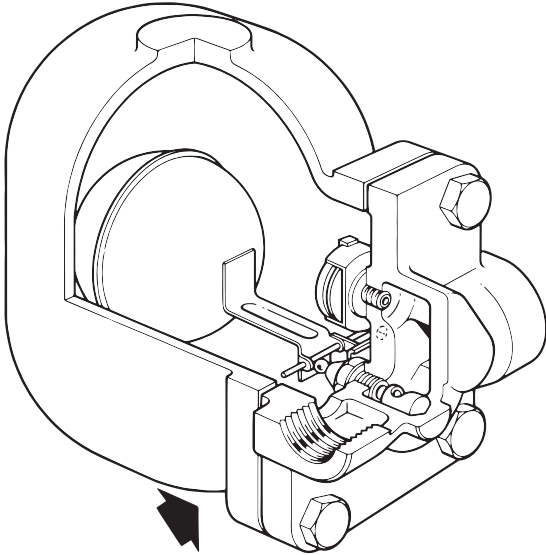

FT14 1½" and 2"

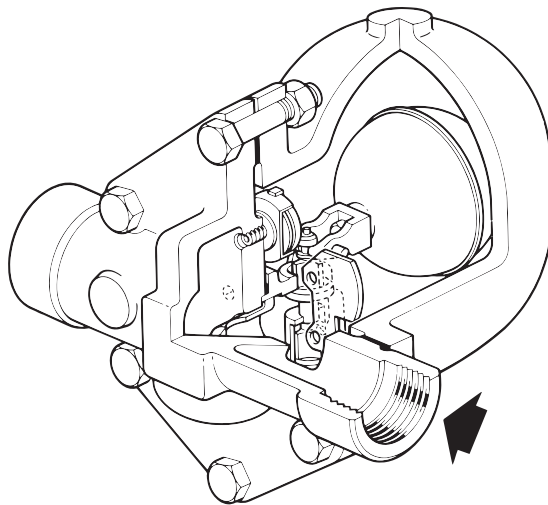
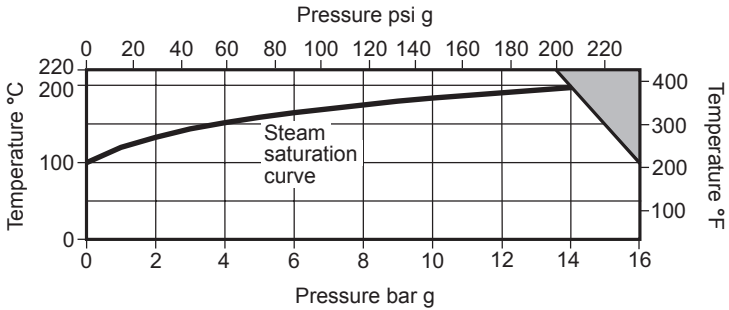



Fig. 1

2.3 FT14 1½" and FT14 2" Pressure / temperature limits





 The product **must not** be used in this region.

Body design conditions		PN16	
PMA	Maximum allowable pressure	16 bar g @ 100°C (232 psi g @ 212°F)	
TMA	Maximum allowable temperature	220°C @ 13.5 bar g (428°F @ 195 psi g)	
Minimum allowable temperature		-10°C (14°F)	
PMO	Maximum operating pressure for saturated steam service	14 bar g (203 psi g)	
TMO	Maximum operating temperature	220°C @ 13.5 bar g (428°F @ 195 psi g)	
Minimum operating temperature		0°C (32°F)	
ΔPMX	Maximum differential pressure	FT14 / FT14HC-4.5	4.5 bar g (62.25 psi g)
		FT14 / FT14HC-10	10 bar g (145 psi g)
		FT14 / FT14HC-14	14 bar g (203 psi g)
Designed for a maximum cold hydraulic test pressure of:		24 bar g (348 psi g)	

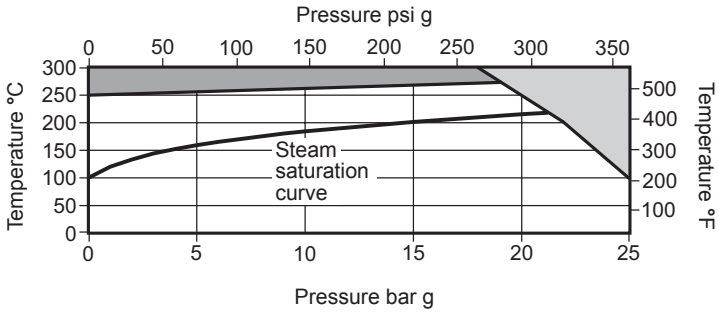
2.4 FT14 1¼" and FT14HC 1" Pressure / temperature limits



 The product **must not** be used in this region.

 The product should not be used in this region as damage to the internals may occur.

Body design conditions		PN25	
PMA	Maximum allowable pressure	25 bar g @ 100°C	(362 psi g @ 212°F)
TMA	Maximum allowable temperature	300°C @ 18 bar g	(572°F @ 261 psi g)
	Minimum allowable temperature	-10°C	(14°F)
PMO	Maximum operating pressure for saturated steam service	21 bar g	(304 psi g)
TMO	Maximum operating temperature	275°C @ 19 bar g	(527°F @ 275 psi g)
	Minimum operating temperature	0°C	(32°F)
ΔPMX	Maximum differential pressure	FT14 / FT14HC-4.5	4.5 bar g (62.25 psi g)
		FT14 / FT14HC-10	10 bar g (145 psi g)
		FT14 / FT14HC-14	14 bar g (203 psi g)
Designed for a maximum cold hydraulic test pressure of:		38 bar g	(551 psi g)

3. Installation

Note: Before actioning any installation observe the 'Safety information' in Section 1.

Referring to the Installation and Maintenance Instructions, name-plate and Technical Information Sheet, check that the product is suitable for the intended installation.

- 3.1** Check materials, pressure and temperature and their maximum values. If the maximum operating limit of the product is lower than that of the system in which it is being fitted, ensure that a safety device is included in the system to prevent overpressurisation.
- 3.2** Determine the correct installation situation and the direction of fluid flow.
- 3.3** Remove protection covers from all connections and protective film from all name-plates, where appropriate, before installation on steam or other high temperature applications.
- 3.4** The trap must be fitted with the float arm in a horizontal plane so that it rises and falls vertically with the direction of flow as indicated on the body. Note that the 1" FT14HC and 1¼" FT14 has a flow pattern from left to right when viewed from the body flange end. All other sizes are right to left.

1"HC and 1¼"	Traps require 160 mm (6.3") withdrawal distance to remove the cover
Note:	
1½" and 2"	Traps require 200 mm (7.9") withdrawal distance to remove the cover

Installation of the manually adjustable needle (SLR) valve

- 3.5** The manually adjustable needle valve is fitted to all float traps where a suffix 'C' is hard stamped on the name-plate e.g. FT14-10C.
- 3.6** Check if the application requires the SLR feature for correct operation. The manually adjustable needle valve should only be used to prevent 'steam locking' and therefore is designed to pass only a small amount of steam.
- 3.7** The manually adjustable needle valve will be dispatched, pre-set to a partial bleed condition. The unit should be screwed clockwise to close and anticlockwise to open. When required the added SLR feature should be used as a controlled continuous bleed, it is not recommended that the SLR be left in the fully open condition as this may lead to premature trap failure and more frequent maintenance schedules.

Warning

The cover gasket contains a thin stainless steel support ring which may cause physical injury if not handled and disposed of carefully.

Please consult Spirax Sarco should further information be required.

Note:

If the trap is to discharge to atmosphere ensure it is to a safe place, the discharging fluid may be at a temperature of 100°C (212°F).

4. Commissioning

After installation or maintenance ensure that the system is fully functioning. Carry out tests on any alarms or protective devices.

5. Operation

The float trap is a continuous discharge trap, removing condensate the instant it forms. On start-up, the thermostatic air vent allows air to bypass the main valve preventing the system air binding. Hot condensate will close the air vent tightly, but as soon as it enters the main chamber of the trap, the float rises and the lever mechanism attached to it opens the main valve - keeping the system drained of condensate at all times. When steam arrives, the float drops and closes the main valve. Float traps are renowned for their high start-up load handling capability, clean tight shut-off and resistance to waterhammer and vibration.

6. Maintenance

Note: Before actioning any maintenance programme observe the 'Safety information' in Section 1.

Warning

The cover gasket contains a thin stainless steel support ring which may cause physical injury if not handled and disposed of carefully.

6.1 General information

Before undertaking any maintenance on the trap it must be isolated from both the supply line and return line and any pressure allowed to safely normalise to atmosphere. The trap should then be allowed to cool. When assembling, ensure that all joint faces are clean.

6.2 How to fit the main valve assembly:

Size 1" and 1¼":

- Remove the cover (4) from the body (1).
- Unscrew the support and pivot frame (9 and 10) and the valve seat (5 and 6).
- Ensure the seat/gasket faces are clean and dry.
- Fit the valve seat to the body (5 and 6 - Do not use gasket paste).
- Attach the support frame and pivot frame to the body with assembly set screws (7) but do not tighten.
- Fit the float arm (8) to the pivot frame (10) using the pin (11) and by moving the complete assembly centre the valve head onto the seat orifice.
- Tighten the assembly set screws (7) to the recommended tightening torque (see Table 1).
- Refit the body (1) using a new gasket (3).
- Retighten the cover bolts/nuts (2) to the recommended tightening torque (see Table 1).

Sizes 1½" and 2":

- Unscrew the 4 bolts or nuts (7).
- Remove the main valve assembly (5, 6 and 7) and replace with new one.
- Tighten the bolts or nuts (7) evenly to the recommended tightening torque (see Table 1).
- Replace cover (1) and a new gasket (3) ensuring the dowel is located correctly.
- Retighten cover bolts/nuts (2) to the required torque (see Table 1).

6.3 How to fit the air vent assembly:

- Remove the spring clip, capsule and spacer plate (17).
- Unscrew the seat.
- Fit a new gasket (18), seat and frame and tighten to the recommended tightening torque (see Table 1).
- Assemble the spacer plate and fit the capsule and spring clip.

6.4 How to fit the manually adjustable needle valve (SLR):

- Unscrew the complete SLR assembly and gasket (19 and 20).
- Remove the SLR gasket (20).
- Replace the SLR assembly and gasket with new ones.
- Reset the SLR to the desired bleed rate.

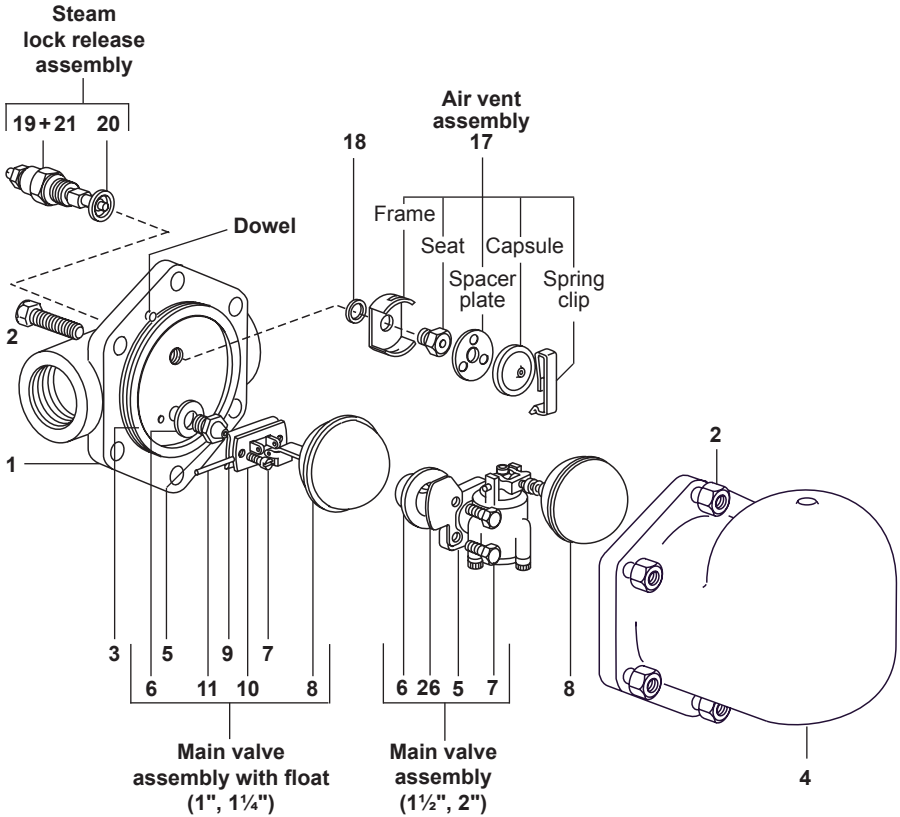



Fig. 2 (Horizontal assembly shown)

Table 1

Recommended tightening torques

*Note: Reduced A/F bolt head required

Item No.	Size		or mm		N m	(lbf ft)
2	1"	17 A/F		M10 x 30	29 - 33	(21.3 - 24.3)
	1 1/4"	14 A/F*		M10 x 30	29 - 33	(21.3 - 24.3)
	1 1/2"	19 A/F		M12 x 60	60 - 66	(44.1 - 48.5)
	2"	24 A/F		M16 x 70	80 - 88	(58.8 - 64.7)
5	1", 1 1/4"	17 A/F		-	40 - 45	(29.4 - 33.1)
7	1", 1 1/4"	-		M5 x 20	10 - 12	(7.3 - 8.8)
	1 1/2"	10 A/F		M6 x 20	10 - 12	(7.3 - 8.8)
	2"	13 A/F		M8 x 20	20 - 24	(14.7 - 17.6)
17	-	17 A/F		-	50 - 55	(36.8 - 40.4)
19	-	21 A/F		-	40 - 45	(29.4 - 33.1)

7. Spare parts

The spare parts available are shown in heavy outline. Parts drawn in broken line are not supplied as spares.

Available spares

Main valve assembly with float (1", 1¼")	5, 6, 7, 8, 9, 10, 11
Main valve assembly with erosion deflector (1½", 2")	5, 6, 7, 26
Ball float (1½", 2")	8
Air vent assembly	17, 18
Manually adjustable needle valve and air vent assembly	17, 18, 19, 20, 21
Complete set of gaskets (packet of 3 sets)	3, 6, 18, 20

Note: The erosion deflector on the 1" and 1¼" is pressed into the body during manufacture and not available as a spare.

How to order spares

Always order spares by using the description given in the column headed 'Available spares' and state the size and type of trap.

Example: 1 - Air vent assembly for 2" Spirax Sarco FT14 steam trap.

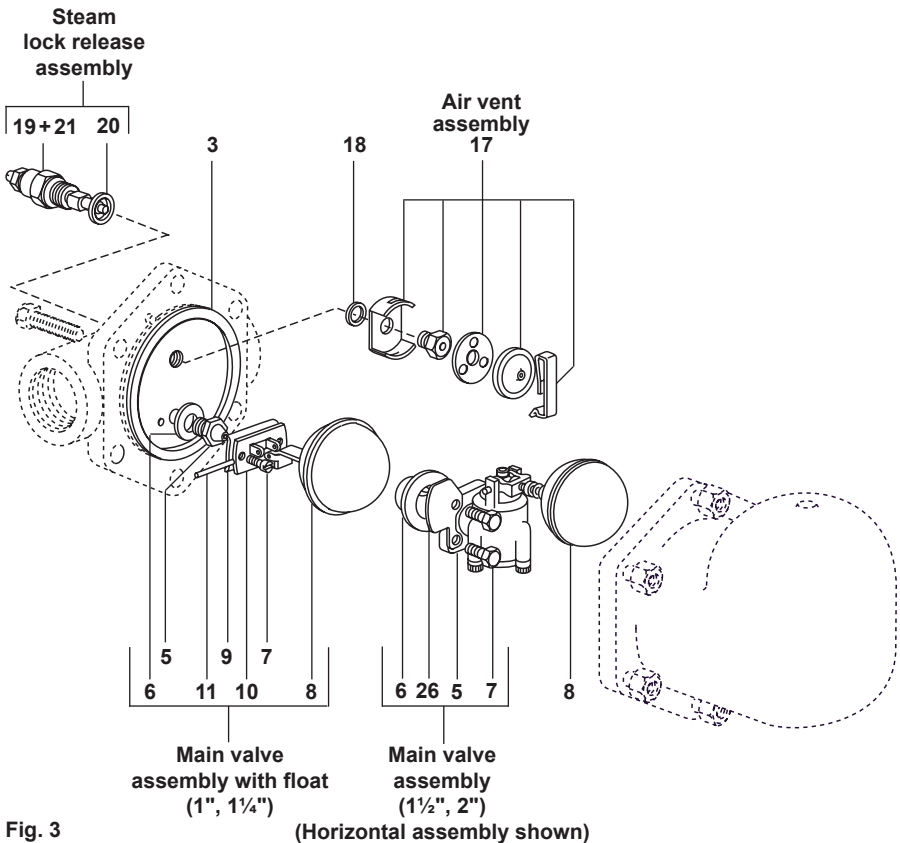

Fig. 3 (Horizontal assembly shown)