



Spira-trol™

Food+

## Two-port Control Valves

Installation and Maintenance Instructions

---

---

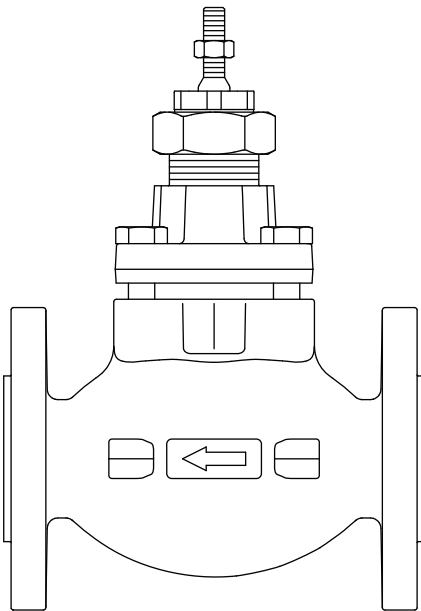

1. Safety information
2. General product information
3. Installation
4. Maintenance
5. Spare parts
6. Fault finding

# 1. Safety information

Safe operation of these products can only be guaranteed if they are properly installed, commissioned, used and maintained by qualified personnel (see Section 1.11) in compliance with the operating instructions. General installation and safety instructions for pipeline and plant construction, as well as the proper use of tools and safety equipment must also be complied with.

## Safety note - Handling precautions



### PTFE

Within its working temperature range PTFE is a completely inert material, but when heated to its sintering temperature it gives rise to gaseous decomposition products or fumes which can produce unpleasant effects if inhaled. The inhalation of these fumes is easily prevented by applying local exhaust ventilation to atmosphere as near to their source as possible.

Smoking should be prohibited in workshops where PTFE is handled because tobacco contaminated with PTFE will during burning give rise to polymer fumes. It is therefore important to avoid contamination of clothing, especially the pockets, with PTFE and to maintain a reasonable standard or personal cleanliness by washing hands and removing any PTFE particles lodged under the fingernails.

## 1.1 Intended use

Referring to the Installation and Maintenance Instructions, name-plate and Technical Information Sheet, check that the product is suitable for the intended use/application.

The products listed on pages 4 to 10 comply with the requirements of the EU Pressure Equipment Directive/UK Pressure Equipment (Safety) Regulations, and carry the  /  marks when so required and fall within the Pressure Equipment Directive categories stated.

- i) The products have been specifically designed for use with liquids and gases which are in Groups 1 and 2 of the above mentioned Pressure Equipment Directive. The products' use on other fluids may be possible but, if this is contemplated, Spirax Sarco should be contacted to confirm the suitability of the product for the application being considered.
- ii) Check material suitability, pressure and temperature and their maximum and minimum values. If the maximum operating limits of the product are lower than those of the system in which it is being fitted, or if malfunction of the product could result in a dangerous overpressure or overtemperature occurrence, ensure a safety device is included in the system to prevent such over-limit situations.
- iii) Determine the correct installation situation and direction of fluid flow.
- iv) Spirax Sarco products are not intended to withstand external stresses that may be induced by any system to which they are fitted. It is the responsibility of the installer to consider these stresses and take adequate precautions to minimise them.
- v) Remove protection covers from all connections, where appropriate, before installation on steam or other high temperature applications.

## LE valves

Product		Group 2 Gases	Group 2 Liquids
LE Food+	PN16	DN15-25	SEP
		DN32-50	SEP
		DN65-100	1

### 1.2 Storage

If the product is to be stored, it must be done so in the original packaging with protective covers in place in order to prevent the ingress of particles that could affect performance. Store in an area free from large temperature fluctuations or high humidity in order to prevent corrosion.

### 1.3 Access

Ensure safe access and if necessary a safe working platform (suitably guarded) before attempting to work on the product. Arrange suitable lifting gear if required.

### 1.4 Lighting

Ensure adequate lighting, particularly where detailed or intricate work is required.

### 1.5 Hazardous liquids or gases in the pipeline

Consider what is in the pipeline or what may have been in the pipeline at some previous time. Consider: flammable materials, substances hazardous to health, extremes of temperature.

### 1.6 Hazardous environment around the product

Consider: explosion risk areas, lack of oxygen (e.g. tanks, pits), dangerous gases, extremes of temperature, hot surfaces, fire hazard (e.g. during welding), excessive noise, moving machinery.

### 1.7 The system

Consider the effect on the complete system of the work proposed. Will any proposed action (e.g. closing isolation valves, electrical isolation) put any other part of the system or any personnel at risk?

Dangers might include isolation of vents or protective devices or the rendering ineffective of controls or alarms. Ensure isolation valves are turned on and off in a gradual way to avoid system shocks.

### 1.8 Pressure systems

Ensure that any pressure is isolated and safely vented to atmospheric pressure.

Consider double isolation (double block and bleed) and the locking or labelling of closed valves. Do not assume that the system has depressurised even when the pressure gauge indicates zero.

## 1.9 Temperature

Allow time for temperature to normalise after isolation to avoid the danger of burns and consider whether protective clothing (including safety glasses) is required.

It is recommended that the valve is insulated in order to reduce the risk of burns when used on steam or other high temperature media.



### PTFE SEALS

If seals made from PTFE have been subjected to a temperature approaching 260 °C (500 °F) or higher, they will give off toxic fumes, which if inhaled are likely to cause temporary discomfort. It is essential for a no smoking rule to be enforced in all areas where PTFE is stored, handled or processed as persons inhaling the fumes from burning tobacco contaminated with PTFE particles can develop 'polymer fume fever'.

## 1.10 Tools and consumables

Before starting work ensure that you have suitable tools and/or consumables available. Use only genuine Spirax Sarco replacement parts.

## 1.11 Protective clothing

Consider whether you and/or others in the vicinity require any protective clothing to protect against the hazards of, for example, chemicals, high/low temperature, radiation, noise, falling objects, and dangers to eyes and face.

## 1.12 Permits to work

All work must be carried out or be supervised by a suitably competent person.

Installation and operating personnel should be trained in the correct use of the product according to the Installation and Maintenance Instructions.

Where a formal 'permit to work' system is in force it must be complied with. Where there is no such system, it is recommended that a responsible person should know what work is going on and, where necessary, arrange to have an assistant whose primary responsibility is safety. Post 'warning notices' if necessary.

## 1.13 Handling

Manual handling of large and/or heavy products may present a risk of injury. Lifting, pushing, pulling, carrying or supporting a load by bodily force can cause injury particularly to the back. You are advised to assess the risks taking into account the task, the individual, the load and the working environment and use the appropriate handling method depending on the circumstances of the work being done.

## 1.14 Safe lifting practice

It is recommended to lift the complete valve assembly using the correct equipment(s) and techniques so as not to cause damage or injury. Valves should be supported under the inlet and outlet connections, not the actuator or accessories, and careful attention should be made to prevent the valve from rotating during the lift sequence. When installed, the neither the valve or its accessories should be used as a hand hold or step for access to other part of the plant.



## 1.15 Residual hazards

In normal use the external surface of the product may be very hot. If used at the maximum permitted operating conditions the surface temperature of some products may reach temperatures of 200 °C (392 °F).

Many products are not self-draining. Take due care when dismantling or removing the product from an installation (refer to 'Maintenance instructions').

## 1.16 Freezing

Provision must be made to protect products which are not self-draining against frost damage in environments where they may be exposed to temperatures below freezing point.

## 1.17 Disposal

Unless otherwise stated in the Installation and Maintenance Instructions, this product is recyclable and no ecological hazard is anticipated with its disposal providing due care is taken. However, if the valve is fitted with a Viton or PTFE component, special care must be taken to avoid potential health hazards associated with decomposition/burning of these seats.

Please visit the Spirax Sarco product compliance web pages:

[www.spiraxsarco.com/product-compliance](http://www.spiraxsarco.com/product-compliance)

for up to date information on any substances of concern that may be contained within this product.

Where no additional information is provided on the Spirax Sarco product compliance web page, this product may be safely recycled and/or disposed providing due care is taken. Always check your local recycling and disposal regulations.

### PTFE:

- Can only be disposed of by approved methods, not incineration.
- Keep PTFE waste in a separate container, do not mix it with other rubbish, and consign it to a landfill site.

Regulation (EC) No 1907/2006 - Registration, Evaluation, Authorisation and Restriction of Chemicals (REACH) Should any substances of very high concern be found within a product, details of the location will be identified within installation and maintenance instructions Section 2.4 : Materials. Further information about product compliance is available at: [www.spiraxsarco.com/product-compliance](http://www.spiraxsarco.com/product-compliance)

## 1.18 Sizing

Control valves should be correctly sized and selected for the application. Incorrect sizing can result in environmental noise limits being exceeded. Poor sizing can also lead to poor control of the process or premature failure of the valve. Please consult Spirax Sarco for guidance.

## 1.19 Returning products

Customers and stockists are reminded that under EC Health, Safety and Environment Law, when returning products to Spirax Sarco they must provide information on any hazards and the precautions to be taken due to contamination residues or mechanical damage which may present a health, safety or environmental risk. This information must be provided in writing including Health and Safety data sheets relating to any substances identified as hazardous or potentially hazardous.

## 1.20 Responsibilities of the operator and operating (including maintenance) personnel.

The operator is responsible for ensuring that safe systems of operation and practice are implemented and maintained. Only competent persons must be allowed to be able to operate and maintain these devices, and these persons must be familiar with, and comply with the applicable health and safety standards or guidelines.

The installation and maintenance instructions should form part of the standard operating procedures for maintenance and must therefore be kept in an accessible location and in a legible condition. Product identification and safety related labels must also be kept in a clean and legible condition. Identification and safety labels must be replaced if they become damaged or obscured in operation.

## 1.21 Installation and maintenance of valves in hazardous environments.

The Spira-trol™ valve is classified as out of scope for ATEX and therefore suitable for use in hazardous environments. However, the valve must be correctly insulated in accordance to any local auto-ignition temperature. Regular cleaning must be considered for areas where dust may settle. Maintenance programs must consider the correct use of non-sparking tools, and the installation must consider the potential for ignition source as a result of dissimilar metals in the pipeline.

# Prevention of waterhammer

Steam trapping on steam mains:

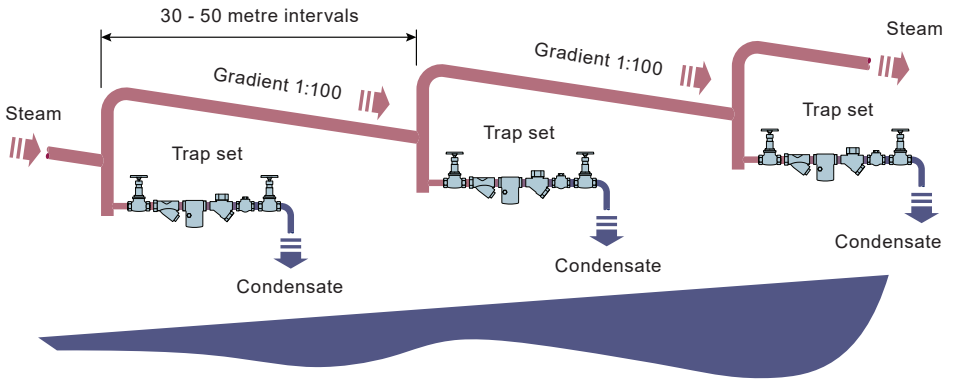

## Steam Mains - Do's and Don'ts:

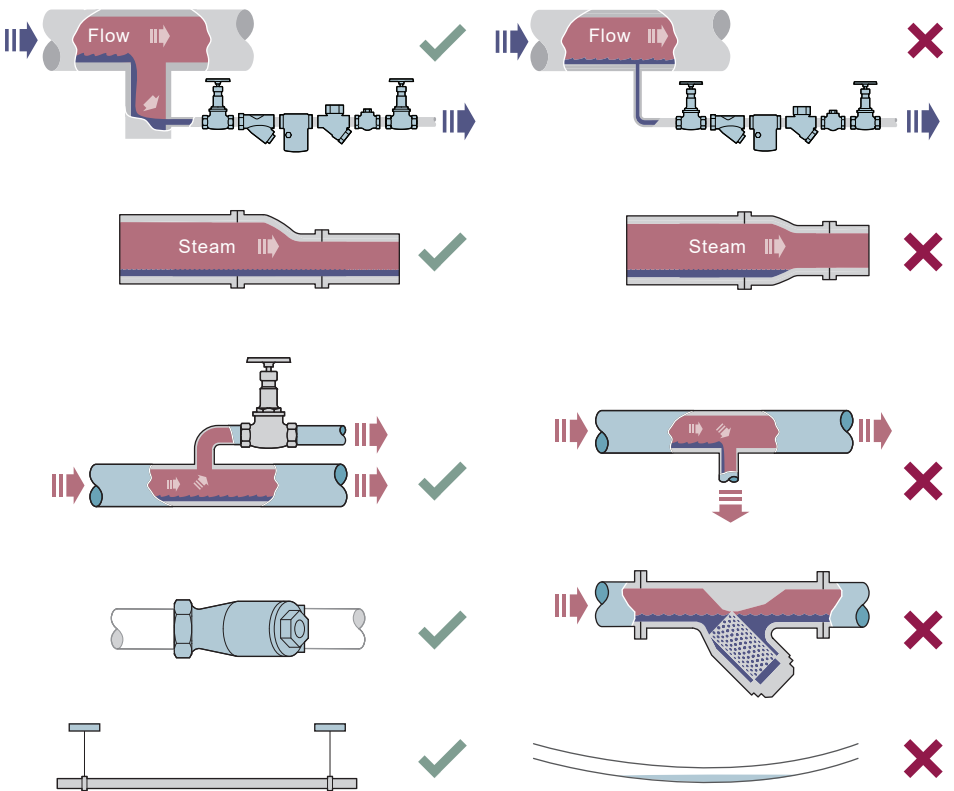

Spira-trol™ Food+ Two-port Control Valves

# Prevention of tensile stressing

Pipe misalignment:

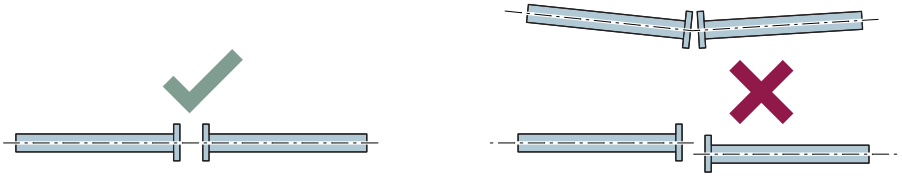

Installing products or re-assembling after maintenance:



Do not over tighten.  
Use correct torque figures.

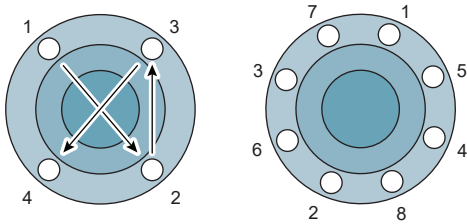

Flange bolts should be gradually tightened across diameters to ensure even load and alignment.



**Thermal expansion:**

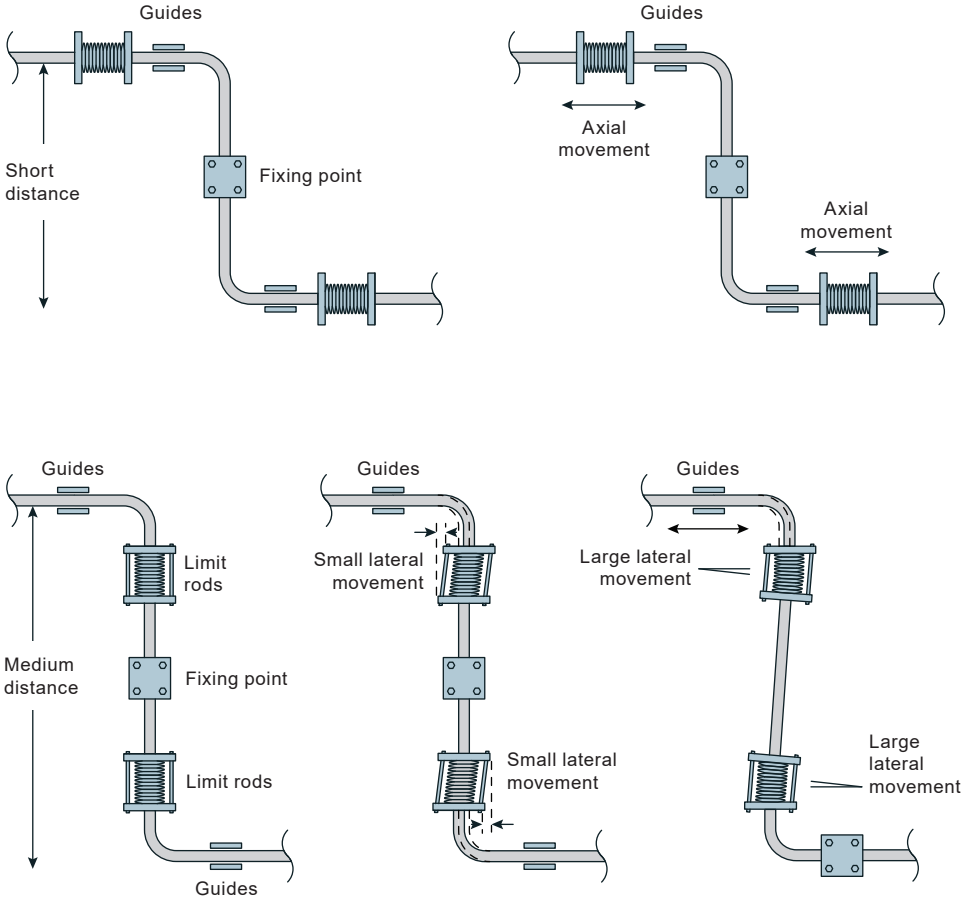

## 2. General product information

### 2.1 General description

Spira-trol™ Food+ is a range of Food Contact Material (FCM) compliant two-port single seat globe valves designed to meet the strict requirements of the Food and Beverage industry.

Designed, manufactured and approved for Steam and Condensate applications. This product complies with EC1935:2004 Food Contact Materials. It also complies with regulation EC2023:2006 (good manufacturing practice for materials and articles intended to come into contact with food). For full compliances, refer to TI-P742-01. This product is also FDA compliant (Title 21 - Food and Drugs).

Spira-trol™ Food+ products will always carry the appropriate symbol reproduced from Annex II of EC1935/2004.



This product is intended to be connected into a system that can operate a food contact compliant process. To minimise the risk of non-intentionally added substances in the system, it is essential that an appropriate CIP (cleaning in place) cycle is carried out by the end user prior to first use in a food contact application.

A list of the materials that could come directly or indirectly into contact with foodstuffs can be found in the Declaration of Compliance available for this product.

Available in EN standard DN15-100 sizes, Spira-trol™ Food+ retains the cage retained design of the standard Spira-trol™ valve for low total cost of ownership and low impact maintenance and will carry the relevant Food Safe mark on the valve and packaging.

When used in conjunction with a pneumatic or electric linear actuator the Spira-trol™ Food+ can provide characterised modulating or on / off control.

### Material Compatibility and Traceability

Material compatibility and traceability of component parts for all Spirax Sarco Food+ products is in accordance with QAS P411. Product lines are migration and organoleptic tested at component level ensuring complete FCM assurance.



All valves are marked with a serial number and carry a certification pack with the matching serial number.

**Spira-trol™ Food+ valve characteristic – options:**

Valve Type	Characteristic	Application
LE	Equal percentage	Suitable for most modulating process control applications providing good control at all flowrates
LF	Fast opening	For on/off applications only
LL	Linear	Primarily for liquid flowcontrol where the differential pressure across the valve is constant

	<p>Throughout this document, reference has been made to the standard LE control valve. With the exception of trim type, the LE, LF, and LL control valves are identical.</p>
---	--

Spira-trol™ Food+ is a modular valve based on 4 body sizes covering DN15-100 (DN15-25, DN32-50, DN65-80, and DN100) sizes in order to reduce the number of spare parts. The valves are available with a range of accessories including actuators, positioners, solenoid valves, limit switches.

**Please refer to respective data sheets:**

- For ASME version please refer to TI-P742-03
- For pneumatic actuators please refer to TI-P357-30
- For smart positioners please refer to TI-P343-34 and TI-P343-36
- For pneumatic positioners please refer to TI-P370-14
- For electro-pneumatic positioners please refer to TI-P343-43 and TI-P343-45
- For electric actuators please refer to TI-P344-02, TI-P714-01 and TI-P713-02

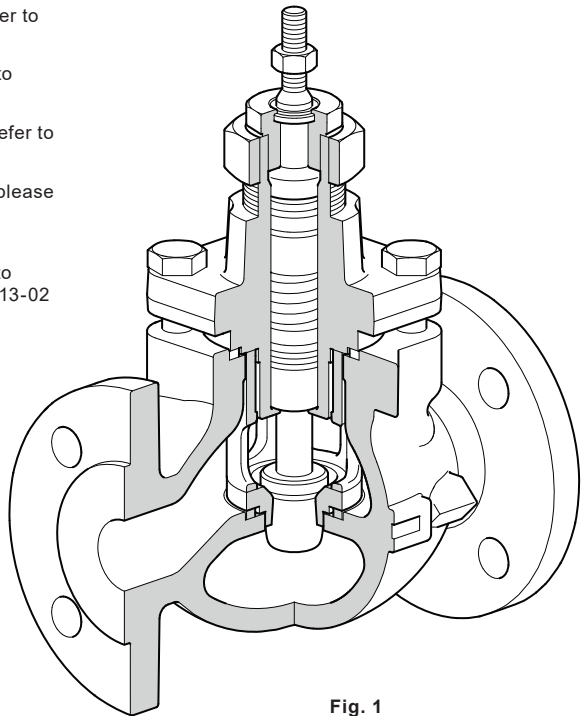
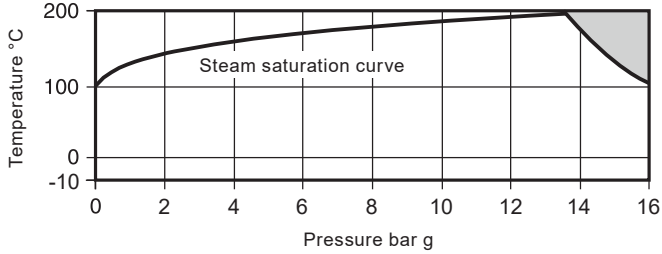

**Fig. 1**

## 2.2 Technical data

<b>Body material</b>		LE6 (316L/EN10213 : 1.4408)		
<b>Nominal pressure</b>		PN16		
<b>Connection type</b>	Flanged	PN16	DN15-100	
<b>Maximum operating pressure</b>	Flanged	PN16	16 bar @ 100 °C	
<b>Maximum operating temperature</b>	Seat Option S	316L	200 °C	
	Seat Option P	PEEK		
<b>Operating temperature range</b>		-10 °C to +200 °C		
<b>Maximum operating temperature</b>	PTFE Stem seal	Seat Option S	200 °C	
		Seat Option P		
<b>Maximum saturated steam service</b>		All options	14.3 bar g	
<b>Leakage class</b>	In accordance to IEC 60534-1	Seat Option S	Class IV	
		Seat Option P	Class VI	
<b>Characteristic</b>		Equal %	Linear	Fast Open
<b>Rangeability</b>		50 : 1	30 : 1	10 : 1
<b>Travel</b>	DN15 to DN50	20 mm		
	DN65 to DN100	30 mm		

## 2.3 Pressure/temperature limits



The product **must not** be used in this region.

Body design conditions	PN16
Maximum design pressure	16 bar g @ 100 °C
Maximum design temperatre	200 °C @ 13.4 bar g
Minimum allowable temperature	-10 °C
Maximum differential pressures	See relevant actuator Technical Information sheet
Maximum cold hydraulic test pressure of :	24 bar g



Where the process fluid temperature is sub-zero and the ambient temperature is below +5 °C (+41 °F), the external moving parts of the valve and actuator must be heat treated to maintain normal operation.

### 3. Installation



Designed, manufactured and approved for Steam and Condensate applications, the Spira-trol™ Food+ product complies with:

- EC1935:2004 Food Contact Materials
- EC2023:2006 manufacturing best practice
- (EU)10/2011 Plastic Materials and Articles Intended to come into Contact with Food
- FDA Code of Federal Regulations - title 21 - Food and Drugs

This product is intended to be connected into a system that can operate a food contact compliant process.

To minimise the risk of non-intentionally added substances in the system, it is essential that an appropriate CIP (cleaning in place) cycle is carried out by the end user prior to first use in a food contact application.



This product is supplied in a clear protective (regulation compliant) polythene bag. This facilitates identification of the valve serial number for traceability and local asset register.

The bag must remain unopened until the point of installation to minimise the risk of non-intentionally added substances entering into the system.

The bag does not remove the requirement for an appropriate CIP cycle to be carried out by the end user prior to first use in a food contact application.



In case of material passivation, Nitric acid concentration must be kept below 30% by volume for valves with full PEEK seats (seat option 'P').

## 3.1 Installation Safety Information



### Caution

Before commencement of any work to inspect, install, commission, remove or modify the Spira-trol™ valve, please read to Section 1 "Safety Information".



### Installation awareness

- Lifting and fitting of valves and actuators increases the risk of personal injury
- A working knowledge of linear control valves actuators is required
- Risk of injury by moving parts. Ensure that the control system is disabled and isolated to ensure that the valve and actuator do not move without warning.

### Crush hazard

- When actuators are to be fitted using lifting equipment always ensure that the valve (& actuator) is carefully slung in order that it cannot fall. Never attempt to remove a control valve from the line by using the actuator as the lifting point. The actuator or the lifting equipment could become damaged.
- Never stand under components that are being lifted. Head safety protection must always be worn when operating on or close to equipment where lifting operations are taking place.
- Do not place hands within the actuator yoke or on the stem of the valve or actuator when isolation of the control system has been removed.
- Do not attempt to restrict actuator stroke or movement, or increase seat load through the placing of objects within the actuator yoke.

### Muscular skeletal damage

- For small valves and actuators that do not require mechanical lifting aids, always ensure that manual lifting best practice is observed. Always use two personnel where possible and ensure that proper access is available in order to ensure a secure foothold.

### High noise

- Control valves can generate high noise under some conditions. Positioners and actuators can also vent air at elevated noise levels. Hearing protection should always be worn when working on or in the immediate vicinity of the valve.

**Note: Before actioning any installation, observe the 'Safety information' in Section 1.**

Referring to the Installation and Maintenance Instructions, name-plate and Technical Information Sheet, check that the product is suitable for the intended installation:

- 3.2 Check materials, pressure and temperature and their maximum values. **Do not exceed the performance rating of the valve.** If the maximum operating limit of the product is lower than that of the system in which it is being fitted, ensure that a safety device is included in the system to prevent overpressurisation.
- 3.3 Ensure selection and installation of all accessories plus the connections including bolting and gaskets are correctly specified and in accordance with the system design temperature and pressure limitations.
- 3.4 In case of pneumatically actuated valves ensure available air pressure available conforms to the requirements and limitation of the actuator and positioner. It is recommended to use a pneumatic filter regulator device to ensure correct conditioning of the pneumatic supply. Please refer to relevant actuator or positioner Technical Information sheet for details.
- 3.5 Remove protection covers from all connections and protective film from all name-plates, where appropriate, before installation on steam or other high temperature applications.
- 3.6 Determine the correct installation situation and the direction of fluid flow. The valve should preferably be installed along a horizontal pipeline with the valve mounted above the pipe (see Figure 3). When mounting an actuator to the valve body, the actuator Installation and Maintenance Instructions must be followed.
- 3.7 **Bypass arrangements** - It is recommended that isolating valves be fitted upstream and downstream of the control valve, together with a bypass control valve. This enables the process to be controlled manually using the bypass valve while the pneumatic valve is isolated for maintenance.
- 3.8 Support pipework should be used to prevent stresses being exerted on the valve body.
- 3.9 Ensure adequate space is provided for the removal of the actuator from the valve body for maintenance purposes.
- 3.10 Isolate connecting pipework. Ensure it is clean from dirt, scale etc. Any debris entering the valve may damage the head seal preventing the specified shut off.
- 3.11 Open isolation valves slowly, until normal operating conditions are achieved.
- 3.12 Check for leaks and correct operation.

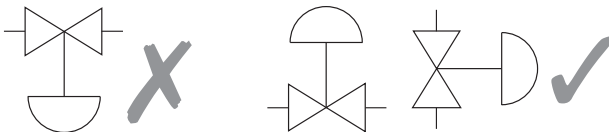

Fig. 2

\*  
Anti-vacuum valve  
recommended for  
steam installations.

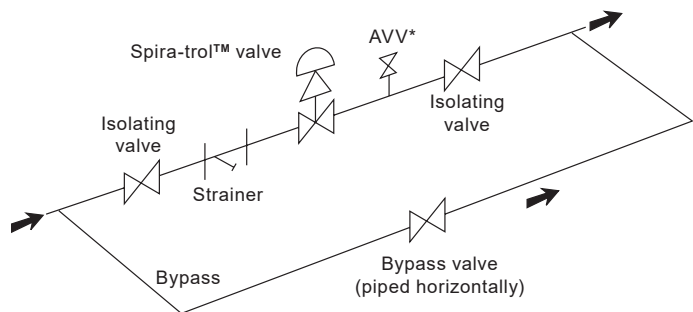

Fig. 3



# 4. Maintenance

## 4.1 Maintenance Safety Information



### Caution

Before commencement of any work to inspect or maintain the Spira-trol™ valve, please read to Section 1 "Safety Information".



### Installation Awareness

- Lifting and fitting of valves and actuators increases the risk of personal injury
- A working knowledge of linear control valves actuators is required
- Risk of injury by moving parts. Ensure that that the control system is disabled and isolated to ensure that the valve and actuator do not move without warning.

### Crush hazard

- When actuators are to be fitted using lifting equipment always ensure that the valve (& actuator) is carefully slung in order that it cannot fall. Never attempt to remove a control valve from the line by using the actuator as the lifting point. The actuator or the lifting equipment could become damaged.
- Never stand under components that are being lifted. Head safety protection must always be worn when operating on or close to equipment where lifting operations are taking place.
- Do not place hands within the actuator yoke or on the stem of the valve or actuator when isolation of the control system has been removed.
- Do not attempt to restrict actuator stroke or movement, or increase seat load through the placing of objects within the actuator yoke.

### Muscular skeletal damage

- For small valves and actuators that do not require mechanical lifting aids, always ensure that manual lifting best practice is observed. Always use two personnel where possible and ensure that proper access is available in order to ensure a secure foothold.

## 4.2 General

Valve parts are subject to normal wear and must be inspected and replaced as necessary. Inspection and maintenance frequency depends on the severity of the service conditions. This section provides instructions on replacement packing, stem, plug and seat and bellows. All maintenance operations can be performed with the valve body in the line.

	<p>Maintenance procedures that involve the valve either being removed from the line or the bonnet or stem seals removed increase the risk of non-intentionally added substances entering the system.</p> <p>It is essential that an appropriate CIP (cleaning in place) cycle is carried out by the end user prior to first use in a food contact application.</p>
---	--

	<p>When placing an order for spare parts please specify clearly the full product description and serial number as found on the label of the valve body, as this will ensure that the correct spare parts are supplied and product compliance can be maintained. Spare parts come complete with a Spirax Sarco Food+ food contact regulation declaration of compliance.</p> <p>No Food+ spare parts will be made available without the valve serial number.</p>
---	--

	<p>In case of material passivation, Nitric acid concentration must be kept below 30% by volume for valves with full PEEK seats (seat option 'P').</p>
---	---

### Annually

The valve should be inspected for wear and tear replacing any worn or damaged parts such as valve plug and stem, valve seat and gland seals, refer to Section 6 'Spare parts'.

	<p>Do not commence any maintenance on the valve body unless the correct spare parts are available to complete the procedure. See Section 5. For details.</p>
--	--

	<p><b>Stainless Steel Valves</b></p> <p>316 stainless steel used in the construction of this product, particularly for screwed or close fitting parts, is very susceptible to galling or cold welding. This is an inherent characteristic of this type of material and great care should therefore be taken when dismantling or reassembling.</p> <p>If the application permits, it is recommended that a light smear of regulation compliant PTFE based grease is applied to any mating part before reassembly.</p>
---	--

	<p>All soft seals and gaskets must be replaced whenever the valve is disassembled.</p>
---	--

## 4.3 Removal of valve bonnet



This procedure is necessary before carrying out any of the maintenance procedures detailed in this document.



Before commencement of any work to inspect or maintain the Spira-trol™ valve, please read to Section 1 "Safety Information".

Ensure the valve is depressurised and clear of media.

Ensure that the valve is correctly isolated from pressure both upstream and downstream.

Ensure that the control system is correctly isolated.

- Remove the actuator from the valve. Refer to the Installation and Maintenance Instructions covering Spirax Sarco actuators.
- Undo and remove the bonnet nuts (27) or the bolt if it is the LE valve.
- Remove the bonnet assembly.
- Remove and carefully dispose of the body gasket.

## 4.4 Replacement of PTFE gland packings (reference Figure 4)

	<p>Spare parts are supplied in a clear protective (regulation compliant) polythene bag. This facilitates identification of the valve serial number for traceability and local asset register.</p> <p>The bag must remain unopened until the point of installation to minimise the risk of non-intentionally added substances entering into the system. The bag does not remove the requirement for an appropriate CIP cycle to be carried out by the end user prior to first use in a food contact application.</p> <p>For spare parts requested with 3.1 material certification it is essential to confirm that the serial number of the valve match with the serial number on the Material Certification supplied with the spare parts and that the spare part packaging carries the appropriate symbol reproduced from Annex II of EC1935/2004.</p> <div data-bbox="564 475 669 593" style="text-align: center;"></div> <p>If the serial numbers are not the same, or the packaging does not carry the appropriate symbol, do not proceed with the planned maintenance procedure and contact Spirax Sarco immediately.</p> <p>The fitting of incorrect spare parts invalidate the conformance of the valve to the regulatory framework.</p> <p><b>Only Spirax Sarco genuine spares must be used.</b></p>
--	---

	<p>Please take careful consideration to refer to Fig. 5 for the orientation of the stem seal components. The orientation is different to standard Spira-trol™ L &amp; K Series valves.</p>
--	--

- Remove the lock-nut (3) and unscrew the gland nut (18).
- Remove the plug and stem (8).
- Remove the gland nut (18).
- Remove and carefully dispose of the scrapper ring (19) from gland nut (18).
- Clean the groove and inside diameter of the gland nut (18).
- Withdraw the gland components and carefully dispose of (9, 10, 11, 12, 13, 15, 16 and 17).
- Clean the gland cavity.
- Fit new gland components with the plastic installation tool.
- Remove and carefully dispose of the plastic installation tool.
- Install scrapper ring (19) in the gland nut (18).
- Apply a slight smear of EC1935 compliant anti-seize lubricant to the gland nut threads before screwing it in two or three turns. At this stage the packing must not be significantly compressed.
- Final adjustment of the gland must be carried out after refitting the bonnet as detailed in Section 4.7.

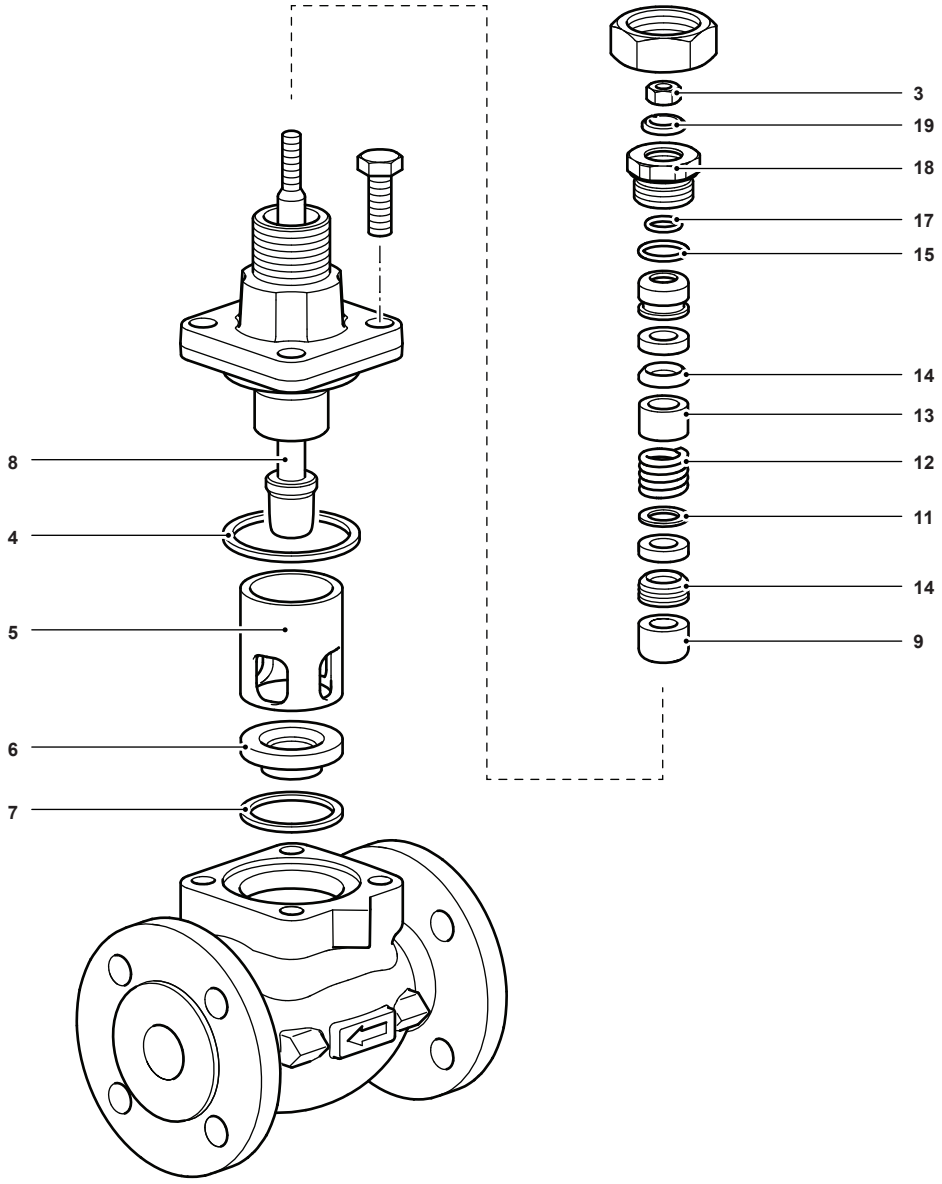





Fig. 4

## 4.5 Removal and refitting of the valve plug/stem assembly and seat

	<p>Spare parts are supplied in a clear protective (regulation compliant) polythene bag. This facilitates identification of the valve serial number for traceability and local asset register.</p> <p>The bag must remain unopened until the point of installation to minimise the risk of non-intentionally added substances entering into the system. The bag does not remove the requirement for an appropriate CIP cycle to be carried out by the end user prior to first use in a food contact application.</p> <p>For spare parts requested with 3.1 material certification it is essential to confirm that the serial number of the valve match with the serial number on the Material Certification supplied with the spare parts and that the spare part packaging carries the appropriate symbol reproduced from Annex II of EC1935/2004.</p>  <p>If the serial numbers are not the same, or the packaging does not carry the appropriate symbol, do not proceed with the planned maintenance procedure and contact Spirax Sarco immediately.</p> <p>The fitting of incorrect spare parts invalidate the conformance of the valve to the regulatory framework.</p> <p><b>Only Spirax Sarco genuine spares must be used.</b></p>
---	---

- Lift out the seat retaining cage (5) followed by the seat (6). Don't damage the seat during dis-assembly.
- Remove the seat gasket (7) and bonnet gasket (4), and carefully dispose of.
- Clean all components, including the seat recess in the valve body.
- Examine the seat and plug/stem assembly for damage or deterioration and renew as necessary. For C Seat option reverse the seat.

	<p>Score marks or scaly deposits on the valve stem will lead to early failure of the gland seal and damage to seat and plug sealing face will result in leakage rates higher than these specified for the valve.</p>
---	--

- Fit a new seat gasket (7) in the body seat recess followed by the seat (6).
- Refit the cage (5) ensuring that the flow windows are lower most and that it sits squarely on the seat without impinging on the valve body.

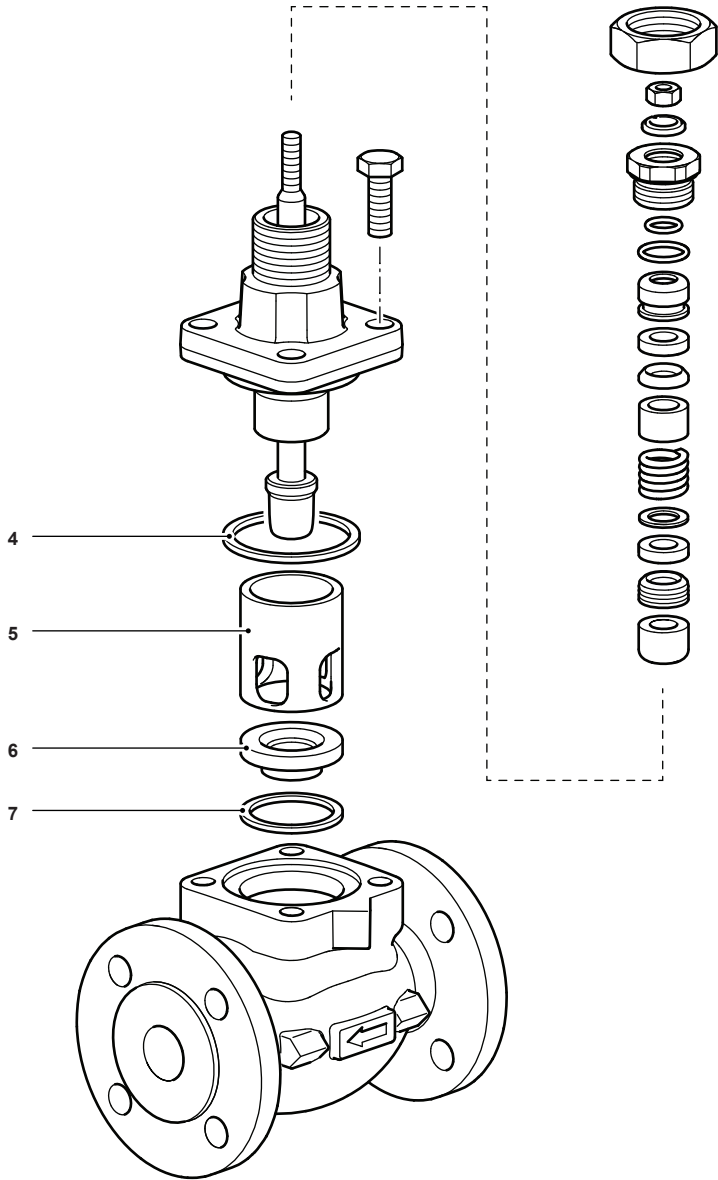

Fig. 4a

## 4.6 Refitting the bonnet

	<p>The following must be carefully followed to enable the correct reassembly of the control valve and the subsequent test that is required to ensure that the plug moves freely into the valve seat.</p>
--	--

- Fit new bonnet gasket (4).
- Apply a light smear of regulation compliant PTFE based lubricant grease at the top of the plug prior to insert it on the cover.
- Ensure the plug stem is fully extended without the upper stem threads making contact with stem seals on the top of the bonnet.
- Replace the bonnet and stem assembly to the valve body, locating the plug centrally into the seat.
- Holding the Plug in position, push the bonnet down on to the valve body.
- Proceed to tighten the bonnet into position by following Step 1 through to 7:



Fit bonnet nuts.



Finger tighten opposing bonnet nuts or bolts evenly in pairs.

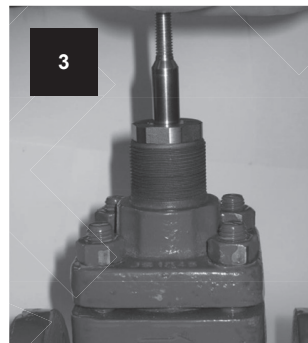

Raise the stem to the highest position.



Repeat Steps 1 to 4 finger tightening bonnet nuts or bolts individually until tight.

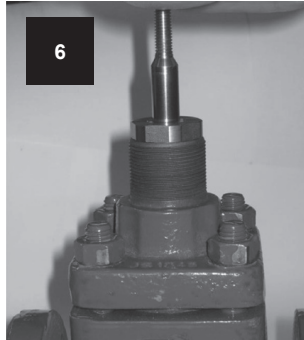

After each tightening sequence lift the stem fully.

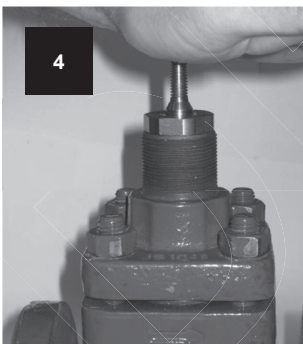

Firmly and briskly push the stem fully down.

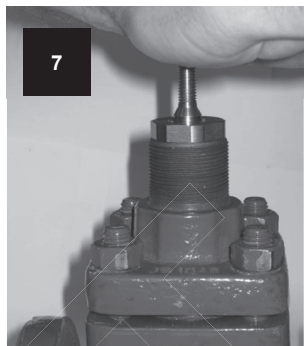

Firmly and briskly push the stem fully down.

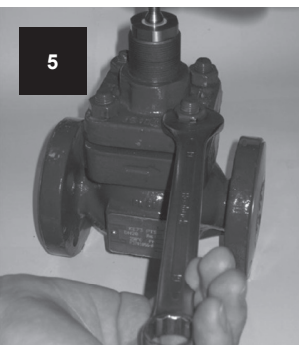

Using a spanner lightly and evenly tighten each bolt or nut by 45°, following the sequence illustrated in Figure 7, page 27.

- Repeat Steps 5, 6 and 7 until the bonnet nuts or bolts have an even tension.
- Continue Steps 5, 6 and 7 but use a torque wrench set at 10% of maximum required torque setting.
- Again, repeat Steps 5, 6 and 7, incrementally increasing the torque value to 20%, 40%, 60%, 80% and finally 100% of the required torque value (as specified in Section 4.7).

- Pull the plug off its seat, rotate by 120° and slowly push it back down into the seat checking for any signs of resistance as the plug comes into contact with the seat.
- Repeat the above Step, three more times.
- If any resistance is felt, this can indicate the plug and seat is misaligned and the process will need repeating.
- Tighten the gland nut (18) until:
  - i) PTFE gland assembly: Metal to metal contact with the bonnet.  
Torque to 20 Nm for DN15 to DN100 and 50 Nm for DN125 to DN200.
- Refit the lock-nut (3).
- Reinstall the actuator.
- Bring the valve back into service.
- Check for leakage at the gland.

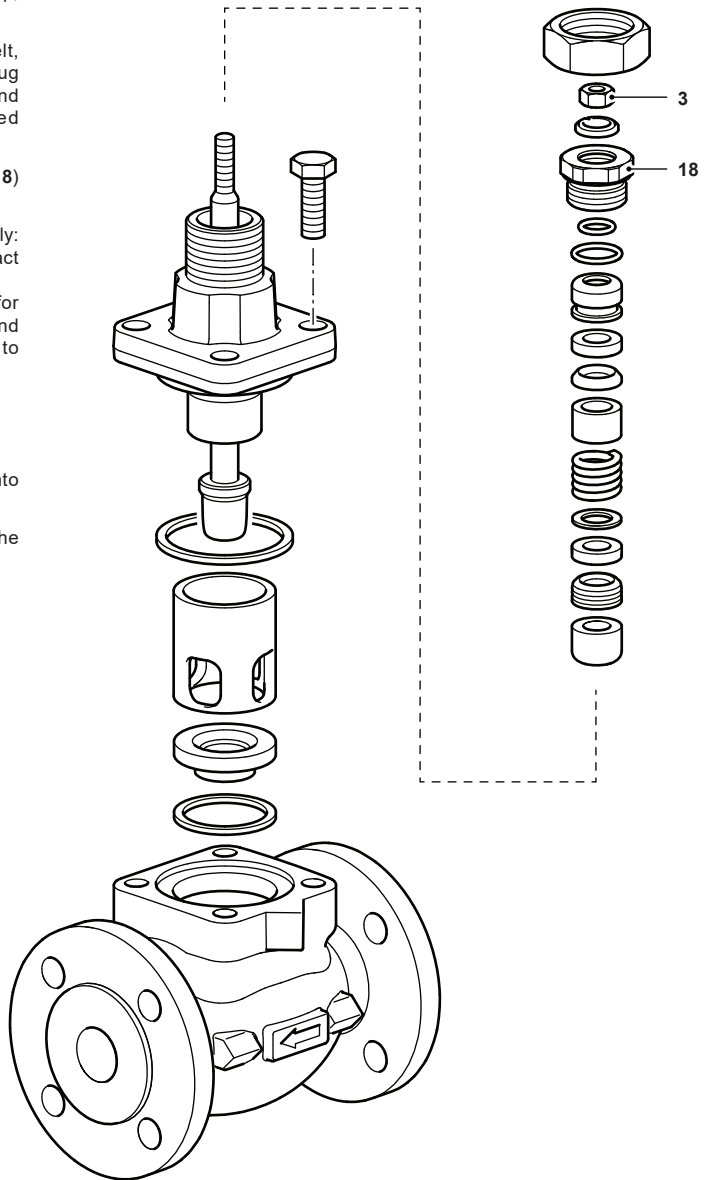
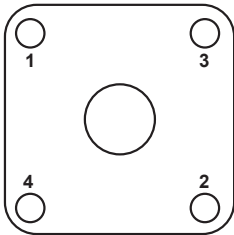

Fig. 5

# 4.7 Recommended Bonnet Tightening Torques

Food + Spira-trol™ Valve size	Torque (Nm)
DN15 to DN25	50
DN32 to DN50	70
DN65 to DN80	130
DN100	100



**Fig. 6**  
4-hole bonnet tightening sequence

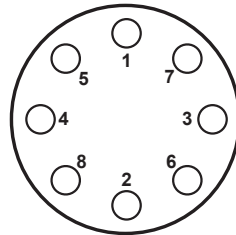

**Fig. 7**  
8-hole bonnet tightening sequence

# 5. Spare parts

## 5.1 Spira-trol™ Food+ Spare parts

Spira-trol™ Food+ spare parts available are shown in solid outline. Parts drawn in a grey line are not supplied as spares.

	<b>Ordering spare parts</b>
	It is essential to confirm that the serial number of the valve match with the serial number on the (3.1) Material Certification Pack supplied with the spare parts.
	The fitting of incorrect spare parts invalidate the conformance of the valve to the regulatory framework.
	<b>Only Spirax Sarco genuine spares must be used.</b>

### Available spares

Actuator clamping nut	A	●
		●
		●
		●
Bonnet Gasket	B	●
Seat Gasket	C	●
PTFE Stem Seal	D	●
Plug and Stem	E	●
Valve Seat	F	●

### Standard spare part kit numbers

Stem Seal and Gasket Set	DN15-25	DN32-50	DN65-80	DN100
		3749060-E	3749061-E	3749062-E

		DN15	DN20	DN25	DN32	DN40	
Plug and Seat Kit (including Stem Seal and Gasket kit)	Full port	Equal %	4	6.3	10	16	25
		Part Number	3759688-E	3759687-E	3759686-E	3759924-E	3759923-E
		Fast Open	4.9	7.2	11	18	31
		Part Number	3749857-E	3749858-E	3749859-E	3749867-E	3749868-E
	Reduction 1	Equal %	2.5	4	6.3	10	16
		Part Number	3749029-E	3759688-E	3759687-E	3759925-E	3759924-E

		DN50	DN65	DN80	DN100	
Plug and Seat Kit (including Stem Seal and Gasket kit)	Full port	Equal %	36	73	100	160
		Part Number	3759922-E	3749276-E	3749277-E	3749291-E
		Fast Open	50	90	117	180
		Part Number	3749869-E	3749876-E	3749877-E	3749881-E
	Reduction 1	Equal %	25	36	73	100
		Part Number	3759923-E	3749275-E	3749276-E	3749290-E

Spira-trol™ Food+ Two-port Control Valves

## How to fit spares

Full fitting instructions are given in the Installation and Maintenance Instructions supplied with the spare.

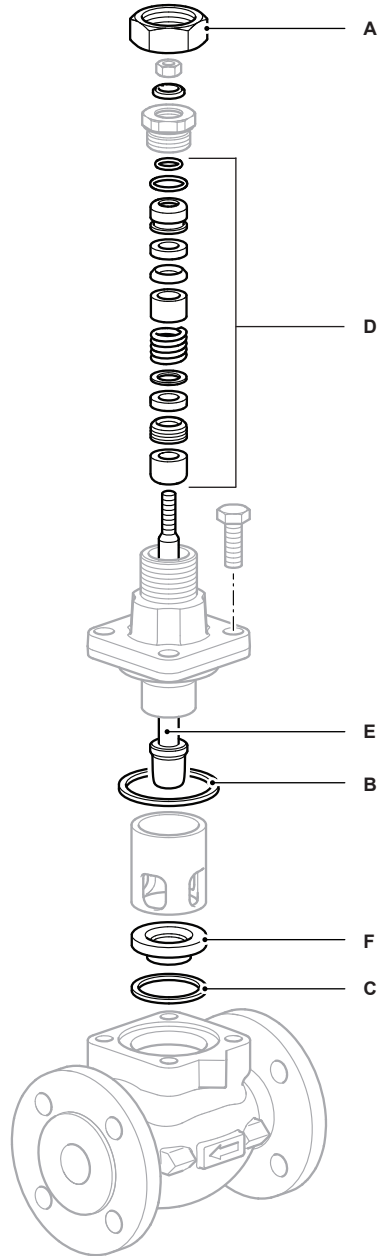

Fig. 8

# 6. Fault finding

Symptoms	Possible Cause	Remedial Actions
<b>Leakage on inlet or outlet</b>	Loose bolt	Retorque correctly the flange if leakage still present, Dismantle the flange and clean and inspect flange gasket face, replace gasket and retorque correctly the flange
	Incorrect bolting used	Dismantle the flange and clean and inspect flange gasket face, replace gasket and bolting and retorque correctly the flange
	Incorrect gasket used	Dismantle the flange and clean and inspect flange gasket face, replace gasket and retorque correctly the flange
	Gasket damage	Dismantle the flange and clean and inspect flange gasket face, replace gasket and retorque correctly the flange
	Flange gasket face damage or unclean	Dismantle the flange and clean and inspect flange gasket face, replace gasket and retorque correctly the flange
	Pressure/temperature not adapt to connection	Check inlet pressure/temperature and refer to Technical sheet
<b>Leakage between body and bonnet</b>	Bonnet gasket is damage	Isolate the valve and proceed for gasket replacment (See maintenance section)
	Missing cover gasket after maintenance	
	Re-use of cover gasket during maintenance	
	Relaxation or undertorque of the bolting	Check the bonnet bolting torque
	Overpressure / temperature	Check the inlet pressure&temperature is in the correct pressure range
	Incorrect fluid passing through the valve	Check the fluid is compatible with the valve materials
<b>Leakage at top of the stem</b>	Stem seals are damage	Isolate the valve and proceed to stem sealing mainetnace (See maintenance section)
	Stem seals wrongly maintain	
	Gland nut need retorque	Check you can stop the leakage by screwing gland nut.
	Overpressure / temperature	Check the inlet pressure&temperature is in the correct pressure range
	Incorrect fluid passing through the valve	Check the fluid is compatible with the valve materials
<b>Leakage between extension and top cover (only on extended bonnet)</b>	Bonnet gasket is damaged	Isolate the valve and proceed to gasket replacment (See maintenance section)
	Relaxation of the bolting torque	Check the bonnet bolting torque
	Overpressure / temperature	Check the inlet pressure&temperature is in the correct pressure range
	Incorrect fluid passing through the valve	Check the fluid is compatible with the valve materials

Symptoms	Possible Cause	Remedial Actions
<b>Leakage in anti-rotation screw (only on bellow D version)</b>	Bellow gasket is damaged	Isolate the valve and proceed to gasket replacement (See maintenance section)
	Relaxation of the bolting torque of the bellow nut	Retorque correctly the bellow nut if leakage still present proceed to gasket replacement (See maintenance section)
	Overpressure / temperature	Check the inlet pressure&temperature is in the correct pressure range
	Incorrect fluid passing through the valve	Check the fluid is compatible with the valve materials
<b>Leakage of the pressure containing shell</b>	Erosion of the envelop	Isolate the valve and replace the product an evaluation of the root cause is needed
	Seat erosion, damage to plug, debris trapped between the plug and seat	Proceed to valve inspection and maintenance as needed. (See maintenance section)
<b>Pressure or temperature of controlled variable rise when valve is closed</b>	Diaphragm or actuator stem seal leak	Proceed to actuator inspection and maintenance.
	Pneumatic supply leak	Check pneumatic supply
	Control signal interruption	Check control signal
	Electrical actuator failure	Proceed to actuator inspection and maintenance.
	Power supply interruption	Check power supply
	Positioner fault	Proceed to positioner inspection and maintenance or replacement.
	Seat gasket missing	Proceed to valve inspection and maintenance as needed. (See maintenance section)
	Relaxation or undertorque of the bolting	Check the bonnet bolting torque
	Seat gasket re-use during maintenance	Proceed to valve inspection and maintenance as needed. (See maintenance section)
	<b>Valve internal un-maintenable due to disformation</b>	Overtorque of body/cover bolting
Seat gasket install wrongly between cage and seat		Proceed to valve inspection and maintenance as needed. (See maintenance section)
Seat not correctly install into the body		
<b>Uncontrollable pressure or temperature of the controlled variable</b>	Cage missing after maintenance	Proceed to valve inspection and maintenance as needed. (See maintenance section)
<b>Non linear stem movement</b>	Mis-maintenance of the stem packing	Proceed to valve inspection and maintenance as needed. (See maintenance section)

Symptoms	Possible Cause	Remedial Actions
<b>Poor control of the manipulated variable in response to control loop</b>	Cage re-assemble upside down	Proceed to inspection and maintenance as needed. (See maintenance section)
	Actuator clamp nut undertorque	
	Stem lock nut missing or undertorque	
	Overpressure / temperature / flowrate	Check application data with sizing sheet. On proceed to valve inspection and maintenance as needed. (See maintenance section)
<b>Actuator moving or turning, plus possible increase of valve stroke, plus possible pressure or temperature of controlled variable rise when valve is closed</b>	Incorrect fluid passing through the valve	Proceed to inspection and maintenance as needed. (See maintenance section)
	Actuator clamp nut undertorque or loose	
<b>Stem to actuator coupling becomes loose - possible damage to stem or actuator (misalignment) / reduction of stroke / Pressure or temperature of controlled variable rise when valve is closed</b>	Stem lock nut undertorque or loose	Proceed to inspection and maintenance as needed. (See maintenance section)
	<b>Air leakage at the air inlet connection (For pneumatic actuated valve)</b>	Air connector defect
Air connector connection damage		Proceed to actuator replacment
Overpressure / temperature		Check inlet air pressure/ temperature and refer to Technical sheet
<b>Air leakage at the actuator stem (For pneumatic actuated valve)</b>	Stem seal is damage	Proceed to stem seal replacment
	Stem is damage	Check stem and proceed to acuator replacment if needed
	Overpressure / temperature	Check inlet air pressure/ temperature and refer to Technical sheet



<b>Symptoms</b>	<b>Possible Cause</b>	<b>Remedial Actions</b>
<b>Air leakage at the actuator stem (For pneumatic actuated valve)</b>	Stem seal is damage	Proceed to stem seal replacement
	Stem is damage	Check stem and proceed to acuator replacement if needed
	Overpressure / temperature	Check inlet air pressure/temperature and refer to Technical sheet
<b>Air leakage at the actuator between yoke and bottom housing (For pneumatic actuated valve)</b>	Yoke gasket is damage	Proceed to gasket replacement
	Bottom housing is disformed	Inspect the housing and proceed to actuator replacement if needed
	Yoke bolt not torque correctly	Check the torque and adjust if needed
	Overpressure / temperature	Check inlet air pressure/temperature and refer to Technical sheet
<b>Air leakage at the actuator diaphragm area between top and bottom housing (For pneumatic actuated valve)</b>	Diaphragm is damage	Proceed to diaphragm replacement
	Bottom or top housing are disformed	Inspect the housing and proceed to actuator replacement if needed
	Diaphragm bolt not torque correctly	Check the torque and adjust if needed
	Overpressure / temperature	Check inlet air pressure/temperature and refer to Technical sheet
<b>Continuous air leakage at the exhaust nut of the actuator (For pneumatic actuated valve)</b>	Diaphragm is damage	Proceed to diaphragm replacement.
	Overpressure / temperature	Check inlet air pressure/temperature and refer to Technical sheet
<b>Valve slow to open or close</b>	Pneumatic supply or exhaust restricted	Proceed to inspection and check speed with actuator Technical sheet





