

## Feedtanks

### Installation and Maintenance Instructions

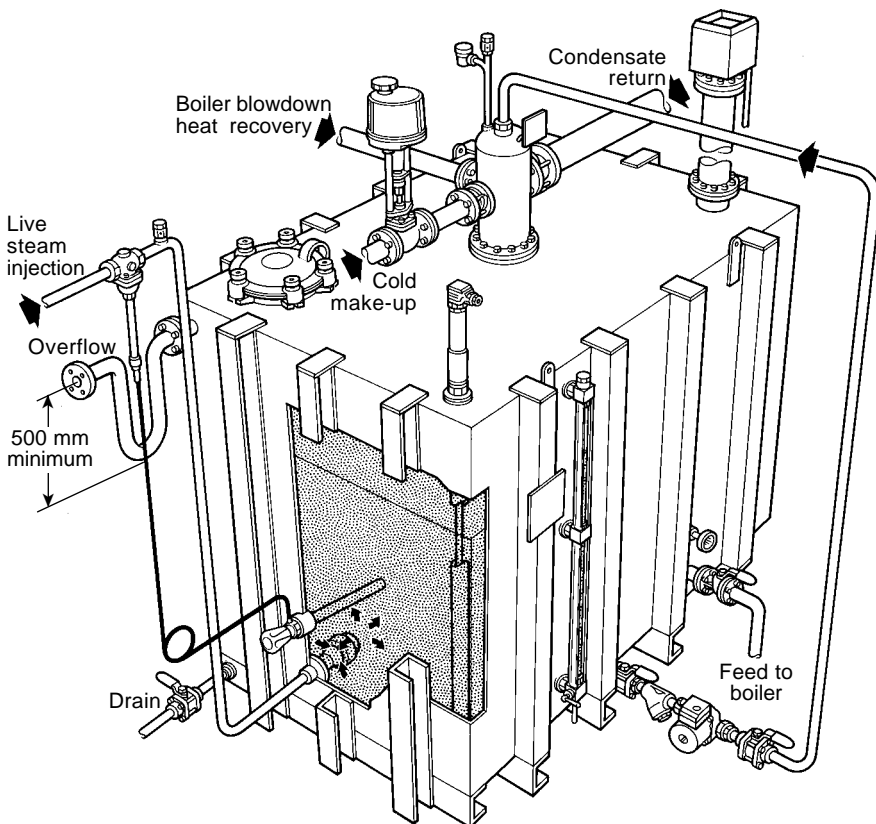

### Safety

Your attention is drawn to Safety Information Sheet IM GCM-10, which is supplied with every delivery. Copies are available free of charge.

#### 1. General

- 1.1 Use the lifting eyes provided to lift the feedtank into position.
- 1.2 Make sure there is enough room above the feedtank for access to the inspection cover.
- 1.3 Remove all plastic plugs and wooden blanks from the feedtank connections.
- 1.4 Fit stainless steel end caps or blanking flanges to all unused connections.

**WARNING:- The vent and overflow connections must never be blanked off.**

- 1.5 Do not attach heavy equipment such as flash vessels, or temperature sensitive equipment, such as level controller housings, to the feedtank sides or stiffeners.

**Note:- As feedtanks are built to customer's individual requirements, not all the equipment described on the following pages will be fitted on every feedtank.**

---

## 2. Tank base

- 2.1 The construction of the feedtank makes it 'self-supporting', so it can be placed on a solid base or on structural steelwork.
- 2.2 In either case, the base/structure must be properly designed to take the operational weight of the tank **plus** its contents.
- 2.3 If required, an insulation material, e.g. rubber, may be used between the base/structure and feedtank to minimise vibration.

**Caution:- To avoid undue stresses on the feedtank do not weld or bolt the tank base supports to the supporting structure.**

## 3. Paint finish

Certain areas of the feedtanks are painted, and slight damage may occur during transit/installation. Consequently, some final site painting may be needed. The primer used is a high-build rapid-dry metal primer, grey zinc phosphate. The topcoat is a professional gloss, colour to BS 4800 18 E53 Gentian.

## 4. Lagging

- 4.1 Use lagging on the whole feedtank including the side stiffeners to conserve heat (with the possible exception of the base).
- 4.2 The inspection cover lagging must be removable.

**Caution:- Use only low or zero chloride content lagging, as leaching of chlorides from lagging onto moist/wet austenitic stainless steel surfaces can cause chloride stress corrosion cracking.**

## 5. Pipework

- 5.1 All pipework must be properly designed with expansion loops and supports so that no loads are imposed on the feedtank connections.
- 5.2 Pipework should be the same nominal pipe size as the feedtank connection.

## 6. Vent pipe

- 6.1 Ideally the vent pipe should be installed vertically and should not be connected to other vent lines. If it has to run horizontally then it should have a slight slope and drain back to the tank.

**WARNING:- Under no circumstances should a check valve or stop valve be fitted in the vent line.**

- 6.2 We strongly recommend the use of a Spirax Sarco vent head to remove much of the entrained water, in order to protect nearby personnel and the building fabric.  
The vent head imposes a minimal back pressure on the tank.
- 6.3 The drain connection of the vent head must be piped to drain, ideally with an air break.
- 6.4 Do not pipe the drain back into the feedtank.

## 7. Overflow

- 7.1 This should always be to a drain at a lower level than the feedtank. It is useful for the overflow to have an air break so that any discharge can be seen.

**Caution:- The connection should never be fitted with a stop valve or check valve.**

- 7.2 Fit a 500 mm U-bend to avoid steam discharge into the drain.

## 8. Drain

- 8.1 The drain must always go to a lower level than the feedtank.
- 8.2 A stop valve should be fitted as near as possible to the feedtank. The Spirax Sarco M10 or M20 ball valve is suitable.

## 9. Feed to pump/boiler

- 9.1 The feedpipe is of large diameter to minimise pressure loss and cavitation at the feedpump(s).
- 9.2 Fit a stop valve (low pressure drop type) at the feedtank. The Spirax Sarco M10 or M20 ball valve is suitable.

---

## 10. Flash condensing deaerator head

10.1 The flash condensing deaerator head fits onto the feedtank flange studs.

10.2 The immersion tube is sandwiched between two rubber gaskets and fits inside the stud circle.

10.3 Fit in the following sequence:-

- Rubber gasket,
- Immersion tube,
- Second rubber gasket,
- Mixing unit.

**Note that full details are given in the deaerator head IMI.**

## 11. Recirculating feedwater spray system

Fit the first stop valve of the system between the feedtank and the strainer/pump, as close to the feedtank as possible.

## 12. Steam injection

12.1 The smallest of the three injectors available, the IN15, has a male and a female thread for direct mounting to a feedtank wall from the outside, or to pipework within the feedtank.

12.2 IN25M and IN40M injectors are available in male thread or butt weld form and are fitted to pipework in the feedtank, or to a feedtank wall connection.

12.3 For higher capacities, two or more injectors may be mounted in parallel.

## 13. Sensor pocket

The sensor pocket is screwed into the connection, which is angled 15 degrees downwards. This is so that the pocket can be filled with a heat conductive paste which provides a fast controller response to changes in feedtank temperature.

## 14. Water level probe connection

This connection is ½" or 1" BSP to suit the probe. Note that the connection has an internal, integral protection tube.

**WARNING:- For outdoor locations it is essential that the probe and all electrical connections are provided with additional environmental protection to IP55 minimum.**

## 15. Water level gauge (WG2)

**Note that the centre support connection (if fitted) does not pierce the feedtank side.**

The drain connection on the bottom arm should be piped to a safe discharge point.

## 16. Dial thermometer

16.1 A dial thermometer (with optional lagging extension) can be used to check the calibration of the steam injector controller as well as indicating the temperature of the feedtank contents.

16.2 A pocket enables the dial thermometer to be removed without draining the feedtank.

## 17. Sample cooler

17.1 We recommend an SC20 sample cooler for taking samples of hot feedwater.

17.2 The ¼" BSP coupling should be fitted to the tank connection and 6 mm O/D stainless steel tube piped to the sample cooler via the sample valve. NPT versions are also available.

## 18. Chemical dosing

18.1 Consult a competent water treatment specialist for advice on the best water treatment. Chemicals, particularly oxygen scavengers, are often dosed into the boiler pipeline and not into the feedtank, as chemically removing oxygen which is also being removed by heating can be wasteful.

18.2 However, if chemicals are to be dosed directly into the tank, fit an internal dip pipe so that the chemicals pass directly into the bulk of the tank contents.

---

## 19. Operation

Feedtanks are reasonably quiet and vibration free in operation, although the mixing of steam and water will inevitably induce a small amount of vibration within the feedtank. If excessive noise, vibration or movement of pipework is experienced then it is essential that the feedtank is not operated until the problem has been identified and rectified.

## 20. Maintenance

The tank is constructed of austenitic stainless steel for long life and needs no maintenance. We recommend that the feedtank is inspected and cleaned if necessary at every major boiler inspection.