

EL2600 Pressure Transmitter Installation and Maintenance Instructions

1. General safety information

Your attention is drawn to Supplementary Safety Information for products used in Steam/Water Applications - IM-F32-01, as well as to any National or regional regulations.

The EL2600 complies with the requirements of the European Pressure Equipment directive 97/23/EC and falls within category 'SEP'.

Safe operation of the product depends on it being properly installed, commissioned and maintained by a qualified person in compliance with the operating instructions.

It is essential to comply with general installation and safety instructions for pipeline and plant construction, as well as to make proper use of tools and safety equipment.

The product is designed and constructed to withstand the forces encountered during normal use. Use of the product for any other purpose, or failure to install the product in accordance with these Installation and Maintenance Instructions, could cause damage to the product, will invalidate the **CE** marking, and may cause serious injury or fatality to personnel.

Warning:

Do not attempt to install, maintain, or remove a pressure sensor unless the pipeline has been depressurised and vented to atmosphere. The fluid remaining in the pressure element of the EL2600 may be hazardous or toxic. This should be considered when handling and storing the pressure sensor. The pressure range of the transmitter, syphon tube and valve must be compatible with the maximum pressure being measured.

This product complies with the requirements of Electromagnetic Compatibility Directive 2004/108/EC by meeting the standards of EN 61 326 Emission (Group 1, Class B) and immunity (industrial locations).

The following conditions should be avoided as they may create interference above the limits specified in EN 61 326 Emission (Group 1, Class B) if:

- The product or its wiring is located near a radio transmitter.
- Cellular telephones and mobile radios may cause interference if used within approximately 1 metre (39") of the product or its wiring.
- The actual separation distance necessary will vary according to the surroundings of the installation and the power of the transmitter.

If this product is not used in the manner specified by this IMI, then the protection provided may be impaired.

Caution:

A 'U' syphon and isolating valve must be fitted if the medium being measured is above 100°C (212°F). Liquid must not be allowed to freeze in the pressure port, syphon tube or valve. The transmitter will be irreparably damaged if the temperature limit is exceeded.

2. General product information

2.1 General description

The EL2600 is a combined pressure sensor and transmitter, designed for general industrial use.

It has a 2-wire 4-20 mA current loop, and a 1/4" NPT process connection.

Weight (approximate) 0.2 kg

2.2 Dimensions (approximate) in mm

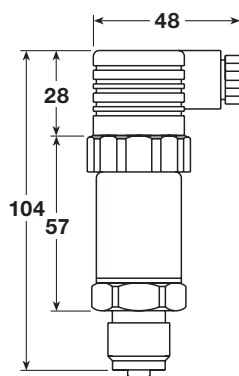

Fig. 1 EL2600 pressure transmitter

2.3 Technical data

The technical specifications below are only accurate after a warming up period of approximately 10 minutes.

Sensor type	0-16 bar a to 0-16 bar g	Piezoresistive
	0-40 bar g to 0-400 bar g	Thin film
Supply voltage	10 Vdc to 30 Vdc	
Signal output	4-20 mA, 2-wire	
Maximum load R_A	$R_A \leq (U_B - 10 \text{ V}) / 0.02 \text{ A}$ with R_A in ohm and U_B in Volt	
Adjustability zero/span	±10% via potentiometers	
Accuracy	≤ 0.5%	
Repeatability	≤ 0.05% of span	
Hysteresis	≤ 0.15% of span	
1 year stability	≤ 0.2% of span (at reference conditions)	
Protection rating	IP65	
Temperature of medium	Minimum -30°C (-22°F) Maximum 100°C (212°F).	
Note:	When the medium is above 100°C (212°F) a 'U' syphon must be used.	
Ambient temperature	Minimum -20°C (-4°F) Maximum 80°C (176°F)	
Shock resistance	1 000 g in accordance with IEC 770 (mechanical shock).	
Vibration resistance	20 g in accordance with IEC 770 (vibration under resonance).	
Wiring protection	Protected against reverse polarity, overvoltage and short circuit.	

Overpressure limit table - As marked on transmitter body:

Calibrated pressure range	Overpressure P max (bar)
0-1.6 bar a	10
0-2.5 bar a	10
0-0.1 bar g	1
0-0.25 bar g	2
0-0.6 bar g	4
0-1 bar g	5
0-1.6 bar g	10
0-2.5 bar g	10
0-4 bar g	17
0-6 bar g	35
0-10 bar g	35
0-16 bar g	80
0-25 bar g	80
0-40 bar g	120
0-60 bar g	200
0-100 bar g	320
0-160 bar g	500
0-250 bar g	800

Note: High pressure 'spikes' above maximum overpressure, even of very short (milli-seconds) duration, could damage sensors. If pressure peaks are likely to occur, we recommend the use of a pressure snubber. Alternatively, a higher range pressure transmitter could be used, though this would mean some loss of signal resolution.

3. Mechanical installation

3.1 Syphon tubes

Two types of syphon tubes and valves are supplied, for low and high pressure applications.

The low pressure type is suitable for a maximum working pressure of 21 bar g @ 217°C (304.5 psi g @ 422°F).

The high pressure type is suitable for a maximum working pressure of 80 bar g @ 450°C (1160 psi g @ 842°F).

Caution: the syphon tube must be filled with water before fitting the EL2600. Ensure the safe operating pressure of the syphon tube exceeds the operating pressure and temperature of the pipeline.

3.2 Pressure sensor

Installation must be carried out in accordance with BS 6739 - British Standard Code for 'Instrumentation in Process Control Systems'. Prior to installing the EL2600, the user must ensure that the appropriate range has been selected, and that the body material is suitable for the specific application. The EL2600 is suitable for use in pipelines where the fluid temperature does not exceed 100°C (212°F). Above this temperature, a 'U' syphon and isolating valve must be used. As syphon tubes are not available for use above 80 bar g (1160 psi g), pressure transmitters for use above 80 bar g (1160 psi g) must not be used for media above 100°C (212°F). We recommend the use of PTFE tape for temperatures up to 250°C (482°F). Above this temperature, a proprietary high temperature sealing compound must be used. Maximum tightening torque is 50 Nm (37 lbf ft).

4. Electrical installation

Cabling should be installed in accordance with BS 6739 - Instrumentation in Process Control Systems: Installation design and practice or local equivalent. Connect the transmitter wiring as shown in Figure 2. Terminal 1 is +ve, terminal 2 is -ve.

The gasket supplied must be fitted under the connector and the screw tightened to achieve sealing to IP65. The cable diameter must be suitable for the cable gland to ensure sealing to IP65. The cable gland must be properly tightened.

Note: Ensure resistance from the probe body to the pipework/boiler is less than 1 Ω.

4.1 Wiring details

Powered current loop input:

Note: terminal 4 (screen) is connected to the body of the EL2600

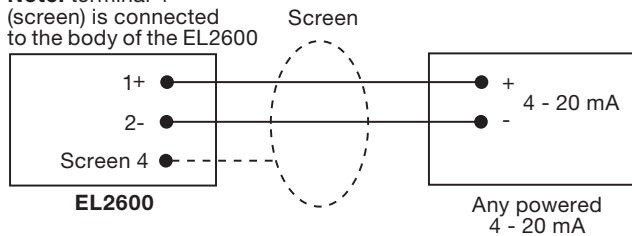

Unpowered current loop input:

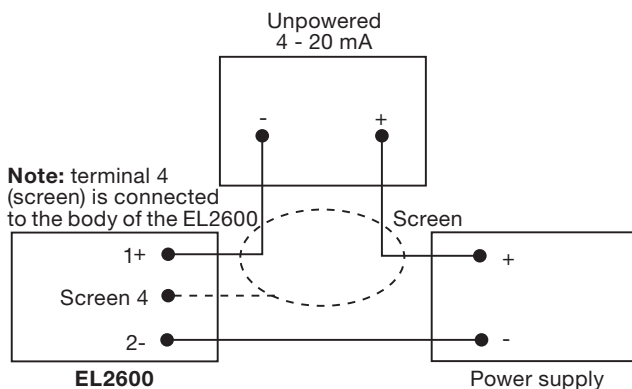

Note: terminal 4 (screen) is connected to the body of the EL2600

Cable requirements:

Use 2 core cable with screen, Maximum cable length is dependant upon cable resistance and drive voltage.

Fig. 2 Wiring details

5. Calibration

EL2600 pressure transmitters are factory calibrated to operate over the stated range.

Regular checks should be made to verify the accuracy of the transmitter system. We recommend that calibration be carried out once a year.

Equipment required for calibration

In order to calibrate the transmitter to the accuracy limits obtained during factory calibration the following equipment is required:

- A pressure source to cover the required instrument range, traceable to National standards, with accuracy of better than ±0.03% of reading.
- A current measurement device with a resolution of at least 0.01 mA and an absolute accuracy (traceable to National standards) of better than ±0.005 mA over the measurement range of 4.00 mA to 20.00 mA.
- A 24 Vdc nominal power supply. If the measurement equipment used is of lower accuracy than the limits stated above, differences between the factory calibration data and the subsequent recalibration data may be found.

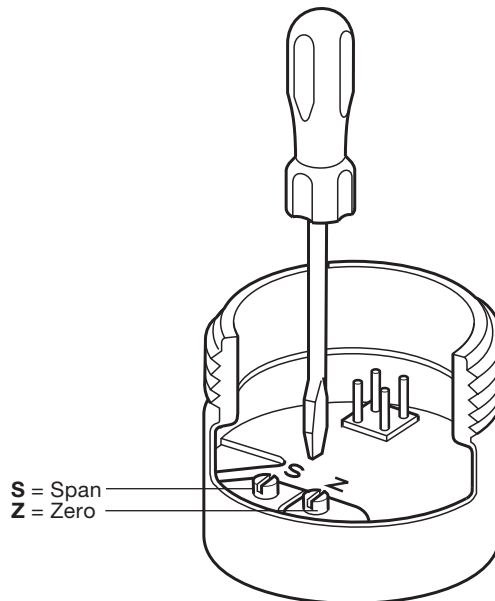

Fig. 3 Calibration - Location of span and zero potentiometers

Calibration procedure

Caution: calibration must be carried out with care, and by suitably qualified personnel, as it is easy to cause damage to the printed circuit board by use of the inappropriate tools.

1. Remove connector retaining ring and connector end plug to expose span (S) and zero (Z) potentiometers.
2. Ensure that the pressure port is clear and dry, and connect calibration equipment.
3. With no pressure applied, use Zero potentiometer to adjust output to 4.00 mA.
4. Apply full-scale pressure and measure the output current (I_o) in mA.
5. Adjust Span potentiometer so I_o = 20 mA ±0.1 mA.
6. Remove pressure from the transmitter.
7. I_o should read 4 mA. If it does not, repeat Steps 2 to 5.

Caution: Small changes to the Zero setting may be made without affecting Span (to compensate for installation errors). Do not adjust the Span control independently, if the setting is disturbed, full recalibration will be required.

6. Maintenance

No specific maintenance is required, but we recommend inspection of the transmitter, its connector, and cable at least once a year. We recommend that calibration be carried out once a year.

Note: No spares are available.