Spirax EasiHeat™ HTG Heating System
Compact Heat Transfer Solution
Installation and Maintenance Instructions



1. Safety information
2. General product information
3. Installation
4. Commissioning
5. Fault finding
6. Maintenance

All rights reserved

Spirax-Sarco Limited grants the legal user of this product (or device) the right to use the Work(s) solely within the scope of the legitimate operation of the product (or device). No other right is granted under this licence. In particular and without prejudice to the generality of the foregoing, the Work(s) may not be used, sold, licensed, transferred, copied or reproduced in whole or in part or in any manner or form other than as expressly granted here without the prior written consent of Spirax-Sarco Limited.

1. Safety information

Note: This document refers only to the mechanical installation and commissioning of the Spirax EasiHeat™ HTG packaged heat exchange system unit and should be used in conjunction with the relevant IMIs for the other system components and supplementary safety information for all the system components.

Warning

This product is designed and constructed to withstand the forces encountered during normal use.

Use of the product for any purpose other than its intended use could cause damage to the product and may cause injury or fatality to personnel.

Before any installation or maintenance procedure, always ensure that all primary steam and condensate return lines and secondary water lines are isolated.

Ensure any residual internal pressure in the system or connecting pipework is carefully relieved.

Allow hot parts to cool before commencing work, to avoid the risk of burns.

Always wear appropriate safety clothing before carrying out any installation or maintenance work.

Lifting

The Spirax EasiHeat™ unit should be lifted by a suitable forklift truck, from the base, placed in position and securely bolted to the floor.

Warning:

On no account is the Spirax EasiHeat™ unit to be lifted by any other part, other than the base.

Note: Sufficient space should be provided around the systems location to allow access for maintenance.

Safe operation of these products can only be guaranteed if they are properly installed, commissioned, used and maintained by qualified personnel (see Section 1.11) in compliance with the operating instructions. General installation and safety instructions for pipeline and plant construction, as well as the proper use of tools and safety equipment must also be complied with.

1.1 Intended use

Referring to the Installation and Maintenance Instructions, name-plate and Technical Information Sheet, check that the product is suitable for the intended use/application. The Spirax EasiHeat™ HTG heating system compact heat transfer unit complies with the requirements of the European Pressure Equipment Directive 97/23/EC - For any product specific PED categorisation that is required for this unit or products used in the make-up of the unit please contact Spirax Sarco directly.

- i) The product has been specifically designed for use on steam, air or water/ condensate which are in Group 2 of the above mentioned Pressure Equipment Directive. The products' use on other fluids may be possible but, if this is contemplated, Spirax Sarco should be contacted to confirm the suitability of the product for the application being considered.
- ii) Check material suitability, pressure and temperature and their maximum and minimum values. If the maximum operating limits of the product are lower than those of the system in which it is being fitted, or if malfunction of the product could result in a dangerous overpressure or overtemperature occurrence, ensure a safety device is included in the system to prevent such over-limit situations.
- iii) Determine the correct installation situation and direction of fluid flow.
- iv) Spirax Sarco products are not intended to withstand external stresses that may be induced by any system to which they are fitted. It is the responsibility of the installer to consider these stresses and take adequate precautions to minimise them.
- v) Remove protection covers from all connections and protective film from all name-plates, where appropriate, before installation on steam or other high temperature applications.

1.2 Access

Ensure safe access and if necessary a safe working platform (suitably guarded) before attempting to work on the product. Arrange suitable lifting gear if required.

1.3 Lighting

Ensure adequate lighting, particularly where detailed or intricate work is required.

1.4 Hazardous liquids or gases in the pipeline

Consider what is in the pipeline or what may have been in the pipeline at some previous time. Consider: flammable materials, substances hazardous to health, extremes of temperature.

1.5 Hazardous environment around the product

Consider: explosion risk areas, lack of oxygen (e.g. tanks, pits), dangerous gases, extremes of temperature, hot surfaces, fire hazard (e.g. during welding), excessive noise, moving machinery.

1.6 The system

Consider the effect on the complete system of the work proposed. Will any proposed action (e.g. closing isolation valves, electrical isolation) put any other part of the system or any personnel at risk?

Dangers might include isolation of vents or protective devices or the rendering ineffective of controls or alarms. Ensure isolation valves are turned on and off in a gradual way to avoid system shocks.

1.7 Pressure systems

Ensure that any pressure is isolated and safely vented to atmospheric pressure. Consider double isolation (double block and bleed) and the locking or labelling of closed valves. Do not assume that the system has depressurised even when the pressure gauge indicates zero.

1.8 Temperature

Allow time for temperature to normalise after isolation to avoid the danger of burns.

1.9 Tools and consumables

Before starting work ensure that you have suitable tools and/or consumables available. Use only genuine Spirax Sarco replacement parts.

1.10 Protective clothing

Consider whether you and/or others in the vicinity require any protective clothing to protect against the hazards of, for example, chemicals, high/low temperature, radiation, noise, falling objects, and dangers to eyes and face.

1.11 Permits to work

All work must be carried out or be supervised by a suitably competent person. Installation and operating personnel should be trained in the correct use of the product according to the Installation and Maintenance Instructions.

Where a formal 'permit to work' system is in force it must be complied with. Where there is no such system, it is recommended that a responsible person should know what work is going on and, where necessary, arrange to have an assistant whose primary responsibility is safety.

Post 'warning notices' if necessary.

1.12 Handling

Manual handling of large and/or heavy products may present a risk of injury. Lifting, pushing, pulling, carrying or supporting a load by bodily force can cause injury particularly to the back. You are advised to assess the risks taking into account the task, the individual, the load and the working environment and use the appropriate handling method depending on the circumstances of the work being done.

Please note that if lifting straps are required we would recommend that they be fitted around the baffle plate legs to prevent damage to the unit.

2. General product information

2.1 General information

The Spirax EasiHeat™ HTG (Heating) incorporating S.I.M.S technology is a complete, compact and ready-to-use steam to water heat transfer solution that delivers superior energy efficient performance. It has been designed for applications with stable load conditions such as closed circuit heating applications. The Spirax EasiHeat™ HTG can help you lower costs, tackle waste and mitigate your environmental impact by reducing your CO₂ emissions and carbon footprint, making a positive change towards a more sustainable future.

The base unit of the Spirax EasiHeat™ provides the core of the system, while options (see Sections 2.2) provide additional features such as: high limit package, stop valve package and energy monitoring.

The Spirax EasiHeat™ HTG unit consists of the following core items (refer to Figure 1):

- A Plate heat exchanger.
- B Pneumatic or electrically actuated control valve and positioner.
- C PLC controller.
- D Pipeline ancillaries.



Fig. 1 Spirax EasiHeat™ HTG compact heat transfer solution

Notes:

1. For additional information about any particular product used in the construction of this unit see the relevant product specific Technical Information (TI) sheet.
2. For further technical information regarding the Spirax EasiHeat™ HTG see the Technical Information sheet TI-P481-01.

2.2 Spirax EasiHeat™ HTG nomenclature

The product nomenclature is a reflection of the core items and unit options that have been ordered and supplied – See the table below:

Spirax EasiHeat™ HTG nomenclature example:

EHH	2	P	EL	-	IHL	B	V2	G1	W	-	E	R2	C2
-----	---	---	----	---	-----	---	----	----	---	---	---	----	----

Spirax EasiHeat™ HTG nomenclature

Compulsory selection	Building heating unit	EHH = Spirax EasiHeat™ HTG	EHH
	CV size	1 = DN15	2
		2 = DN20	
		3 = DN25	
Pressure vessel code	A = ASME	P	
	P = PED		
Actuation	EL = Electric	EL	
	PN = Pneumatic		
Mechanical options	High limit	HL = Integrated high limit	IHL
		IHL = Independent high limit	
	High limit actuation (EL only)	B = Battery back-up	B
		C = Super capacitor	
	Isolation	V1 = Ball valve	V2
V2 = BSA			
V3 = DBB3			
Gasket material	G1 = EPDMPC	G1	
Extras	W = Wheels	W	
	S = EN 12828 safety option		
Panel options	Energy monitoring	E = With energy monitoring	E
	Remote access	R1 = Level 1 – SMS and E-mail	R2
		R2 = Level 2 – Full web access	
R3 = Level 3 – SMS + Remote			
Communications	C1 = Modbus	C2	
	C2 = BACnet		
	C3 = LonTalk (LonWorks)		
	C4 = DeviceNet		
	C5 = CANopen		
	C6 = Profinet		
	C7 = Profibus		

3. Installation

3.1 Steam and condensate connections

It is important that the steam supply (and compressed air if pneumatic actuation is selected) to the Spirax EasiHeat™ HTG unit is supplied as dry and as clean as possible, in accordance with good steam engineering practice.

It should also be ensured that all connecting pipework is stress free and adequately supported.

The steam supply should always be maintained at the specified design pressure and temperature for the unit. The Spirax EasiHeat™ HTG must not operate above the maximum steam pressure and temperature indicated on the name-plate attached to the plate heat exchanger.

The installation of an appropriately sized safety valve, to protect any lower pressured equipment on either the hot or cold side of the plate heat exchanger, is strongly recommended.

Spirax Sarco supplies a range of traps, strainers, separators, safety valves and pressure reducing equipment.

3.2 Air supply

If a pneumatic control system is installed, connect a compressed air supply (4.5 to 8 bar g (65 to 116 psi g)) to the pressure regulator mounted on the control valve.

3.3 Electrical supply

All electrical wiring and connections should be carried out in accordance with National Regulations.

A lockable isolator / switch disconnect should be fitted adjacent to the unit.

Mains supply is directly connected to the primary side of the incoming control panel isolator (shown with the IP2X cover removed) and main earth terminal as shown in Figure 2.

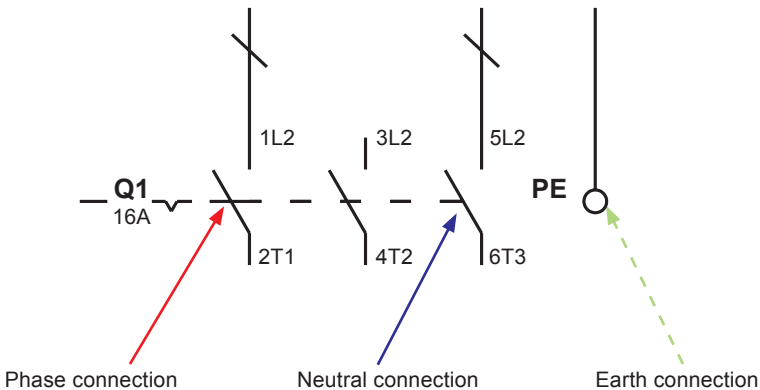

Fig. 2

3.4 Electrical specifications

Electrical supply: Refer to the name-plate on the unit

Control panel supply voltage	110 Vac/60 Hz
	240 Vac/50 Hz
Control panel load requirements	Internally fused at 5 amps
Electrical control actuator	24 Vac
	4 - 20 mA control
Pneumatic control actuator	-
	4 - 20 mA control
High Limit isolation valve (optional)	24 Vac
Steam flowmeter TVA (optional)	4 - 20 mA control
PT100 temperature sensors	3 wire

Note: Power supply 10 - 16 A

3.5 Electrical connections

The following are available for customer connection to the Spirax EasiHeat™ system if required:

Volt free contacts

Terminal designation	Description	Type
X14	Enabled/running signal	1 x N/O contact
		1 x N/C contact
X15	High Limit alarm	1 x N/O contact
		1 x N/C contact
X16	Band Alarm	1 x N/O contact
		1 x N/C contact

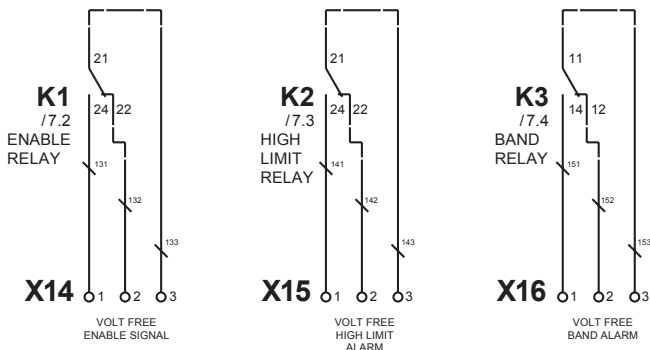

Fig. 3

Remote operation and retransmission connections

Terminal designation	Description	Type
X7	Remote set point	4-20 mA input
X17	Remote enable	24 Vdc signal
X9	Retransmission value	4-20 mA output

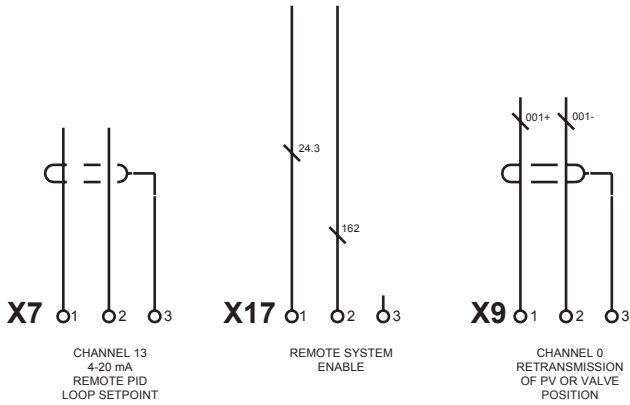

Fig. 4

Terminal layout overview

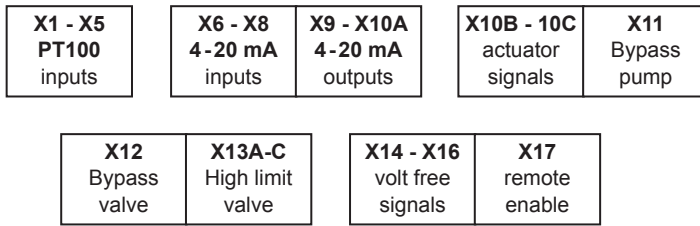

Fig. 5

Terminal layout detailed

Note: for detailed wiring schematic options please refer to the 'Operations manual'.

1. Basic
2. Independent high limit
3. Independent high limit with safety
4. American standard

- X1 - Water temperature IN
- X2 - Water temperature OUT
- X3 - Steam temperature
- X4 - Condensate temperature
- X5 - High limit temperature

Group X6 to X10A

- X6 - Linear actuator feedback
- X7 - Remote PID loop set point
- X8 - Steam flow
- X9 - Retransmission value
- X10A - Linear actuator control position

Group X10B to X11

- X10B - Linear actuator closed signal
- X10C - Linear actuator supply voltage (Electric actuator only)
- X11 - Bypass pump
- X12 - Bypass valve
- X13 - High limit valve
- X13A - High limit valve control output signal
- X13B - High limit valve supply voltage (electric actuator only)
- X13C - High limit valve battery signal

Group X14 to X17

- X14 - Volt free signal for enabled
- X15 - Volt free high limit
- X16 - Volt free band alarm
- X17 - Remote enable signal

4. Commissioning

We recommend that you use the service and support of a Spirax Sarco commissioning engineer. Details of this service can be found by contacting Spirax Sarco.

Note: Pre commissioning requirements:

- In most new installations, dirt collects in the steam pipeline during construction of the system. It is essential to flush this out prior to commissioning.
- Ensure the secondary (cold side) of the system is charged and all air is bled from the system.
- Ensure that all main isolation valves for both steam and water are isolated.
- Ensure that the electrical supply to the Spirax EasiHeat™ is isolated.
- Double check that all steam, condensate and water connections are correctly connected to the Spirax EasiHeat™.
- Check all flange bolts are tight.

4.1 Mechanical commissioning procedure:

- Check that all the electrical connections are secure and as per the wiring diagram (Section 3.3, Figure 2).
 - Dry commissioning valve stroke check - An initial valve stroke check should be carried out to ensure free movement of the valve stem.
1. For the electric actuated control valve, use the manual override on top of the actuator to raise and lower the actuator spindle between the two travel indicators located on the side of the pillar (Figure 6).

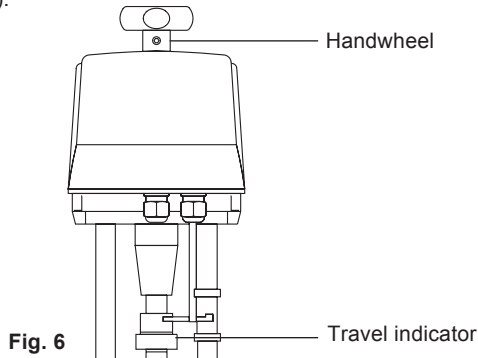

Fig. 6

2. For the pneumatic actuated control valve, remove the existing air supply and connect an independent air supply to the actuator (pressure not to exceed 6 bar g (87 psi g)), allow the valve to fully open, remove the air supply from the actuator allowing the valve to close. Reconnect the original pipework (Figure 7).

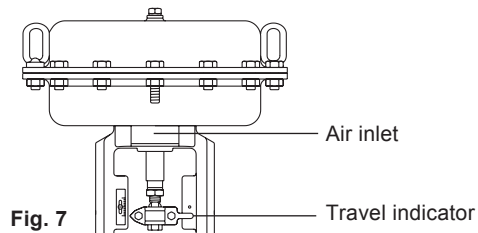

Fig. 7

- Open the secondary (cold side) isolating valves downstream of the Spirax EasiHeat™.
- Start the main secondary water circulating pump(s) if fitted.
- Check and confirm there is secondary water circulation through the Spirax EasiHeat™.
- If the circulation is okay, switch on the main power to the control panel (local isolator).
- Turn the control panel isolation switch to 'ON'.
- Follow the quick start-up guide (WHERE) before opening the steam isolations valves.

4.2 TVA quick commissioning:

The TVA flowmeter is factory set to display data in metric units (changeable to imperial if required by following the flow chart, Figure 10, or the individual product Installation and Maintenance Instructions (IMI)).

All commissioning of the TVA is through the arrow buttons located on the front display see Figure 8.

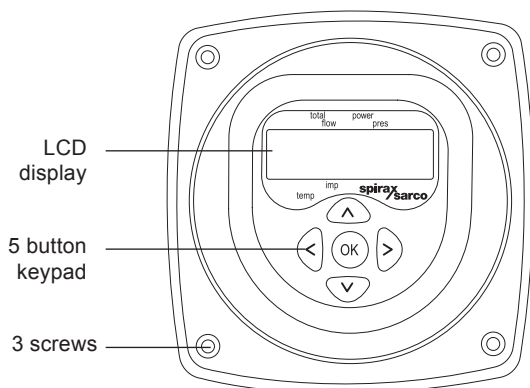

Fig. 8

Press and hold down the 'OK' button and hold for 3 seconds, then enter the default pass code.

Use the up and down arrows to set the number then press OK to confirm your selection, repeat until all numbers are entered.

Fig. 9



4.2.1 TVA flowmeter commissioning chart

To navigate around the first level menu use the up and down arrows, to enter any sub menu use the right arrow.

Fig. 10 TVA configuration displays

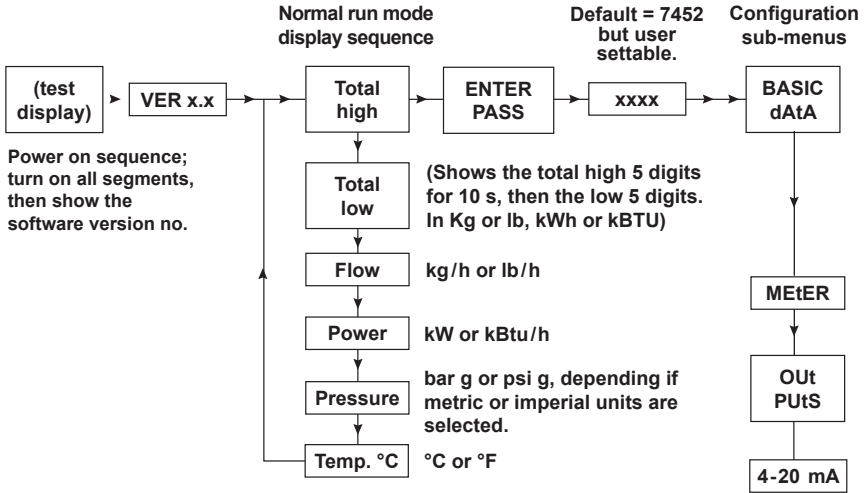

Error Messages

These alternate with the normal run mode display. They will be prioritised and will be latched when they occur.

Pressing the 'OK' button will cancel the displayed alarm and allow the next one to be viewed.

A continuous alarm will re-occur on the display 2 seconds after it has been cancelled.

Power interrupted
POWER OUT

No signal from sensor
NO SIGNAL The 4-20 mA alarm can also be activated

Signal from sensor constant
SENSR CONST The 4-20 mA alarm can also be activated

Flow above maximum
HIGH FLOW Shows when flow i / p exceeds MAX A

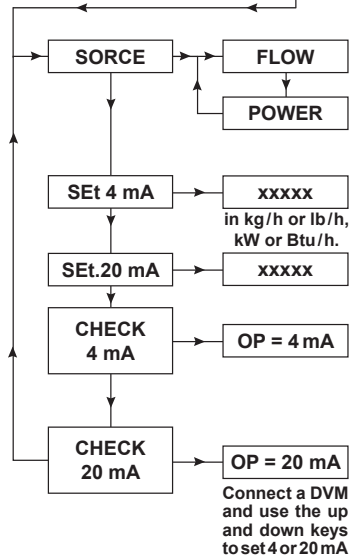

From the Basic dAtA menu navigate to OutPUtS and press the right arrow to enter the sub menu of 4 - 20 mA.

Fig. 11

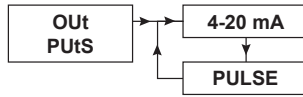

The next menu Sorce will need FLOW to be selected.

Obtain the correct flow data from the Spirax EasiHeat™ specification sheet supplied for accuracy, thereafter navigate down the menu and input: -

Minimum flow = 4 mA
 Maximum flow = 20 mA

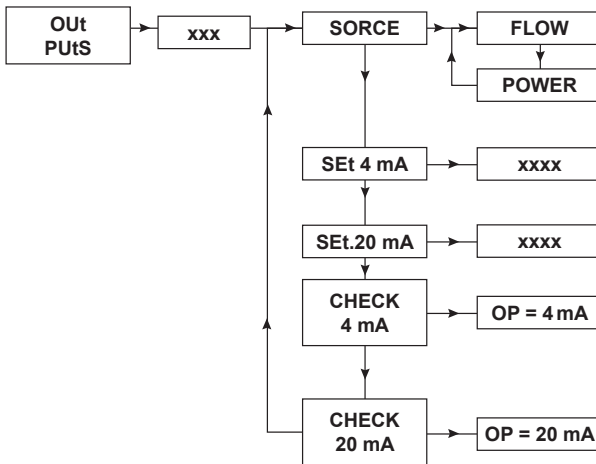

Fig. 12

After this data has been input, continually press the left arrow button to take you back to the run mode.

This completes the basic requirement for scaling of the TVA flowmeter suitable for integration with the HMI.

4.3 HMI quick start commissioning procedure:

The HMI display is a 7" touch screen, and the following procedures detail a basic set-up of the control system from initial power up. A more detailed description of each individual feature can be found in the full operation and maintenance manual.



Fig. 13

When ready the above screen will appear - touch the screen. If the unit has not already been configured the following page will appear:

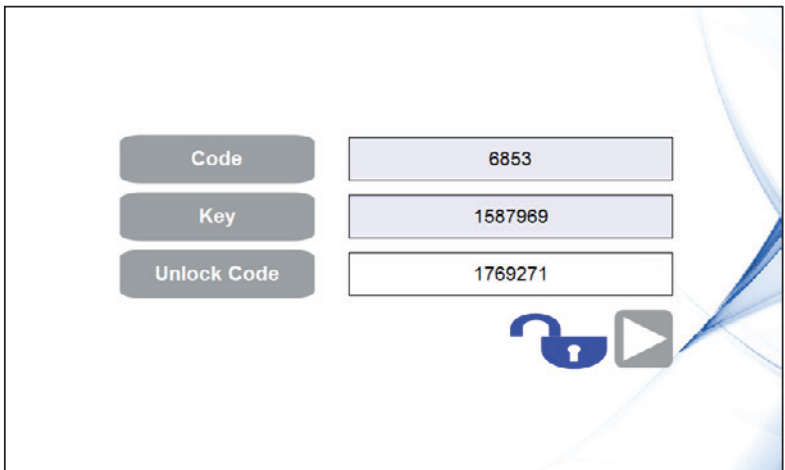

Fig. 14

To be able to move to next page the unlock code is essential, after entering the correct unlock code, the lock icon and the continue button will appear which will transfer you to the time/ date setting page - See Figure 15.

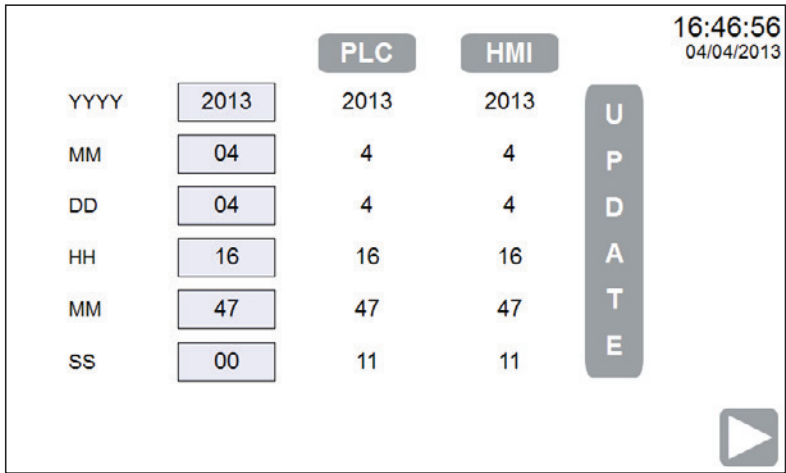

Fig. 15

After unlocking the system (by using the unlock code) and setting the time and date or if the unit has been returned to factory default one of the following four pages will appear (pre-configured for designated region):



Fig. 16

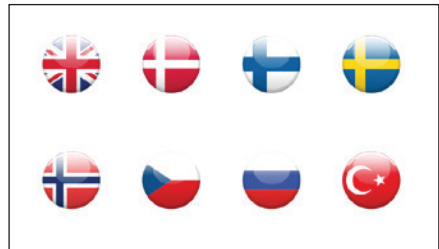

Fig. 17

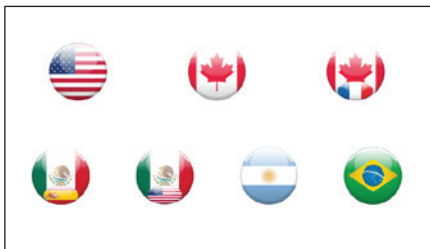

Fig. 18

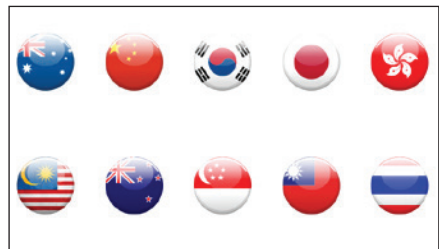

Fig. 19

By choosing the relevant flag for your Country the common default engineering units and language will automatically be selected for that region. These values can be changed after the initial commissioning set-up procedure has been completed (see page 32).

The system will advance automatically to allow the selection of the relevant Spirax EasiHeat™ unit - The type of Spirax EasiHeat™ unit that is available is dependent on the flag selection.

The next screen (Figure 20) requires confirmation of the system to be configured:

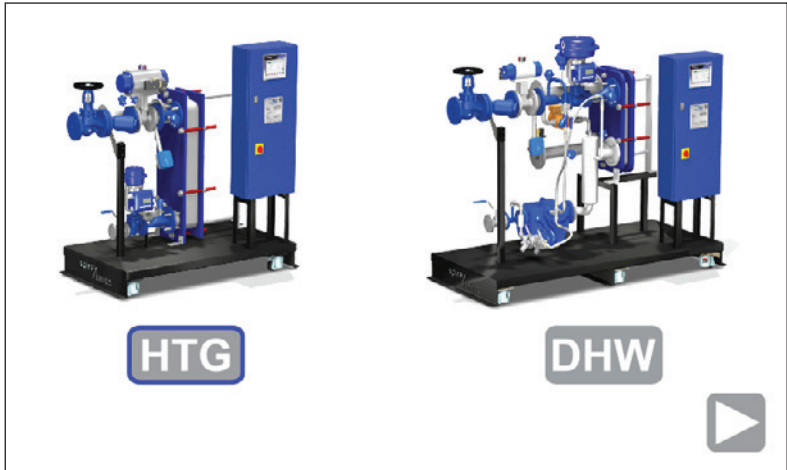

Fig. 20

Based on the selection of a HTG system the selection will be confirmed by the icon becoming highlighted with a blue surround and a continue button will appear.

Press the continue button to advance to the system configuration menu.

The system configuration is now required to be entered on this page; again a selection is highlighted by a blue surround around the icon.



Fig. 21

The system configuration should match the mechanical configuration of the Spirax EasiHeat™ and control system of the plant, correct configuration will show or hide options that are available after configuration. Some of the screens may contain additional options which with specified configuration may be hidden; all the options are described in this document.

Spirax EasiHeat™ mechanical and control system configuration options are detailed below and page 20:

Fig. 22 High-limit selection



Not installed



PLC controlled



Independently controlled

Fig. 23 1/4 turn actuator selection



BVA



PSA



Valpes

Spirax EasiHeat™ mechanical and control system configuration options continued:

Fig. 24 Linear actuator selection



Electrical



Pneumatic

Fig. 25 Linear actuator control signals



No position feedback



Position feedback

Fig. 26 Enable control selection



Local



Remote



BACnet

Fig. 27 PID set point
(Outside weather compensation)



Local



OWC

Fig. 28 TVA flowmeter selection



Not installed



Installed

Fig. 29 Cost calculation



Disabled



Enabled

TVA not installed and no outside weather compensation selected

If the Spirax EasiHeat™ unit is not fitted with a TVA flowmeter then the system configurations are now complete and the continue navigation button at the bottom right of the screen can be used to navigate to the next page which is the Start Page (with the blue hand).



Fig. 30

TVA installed and outside weather compensation selected

On TVA flowmeter selection a data entry point shall be displayed in order for effective scaling of the flowmeter (full engineering range for the 4-20 mA signal input to the Spirax EasiHeat™ system). The full range values entered at this point should match exactly those that are programmed in the TVA flowmeter parameters (Refer to Sections 4.2 and 4.2.1 for TVA commissioning data) as well as outside weather compensation set point.

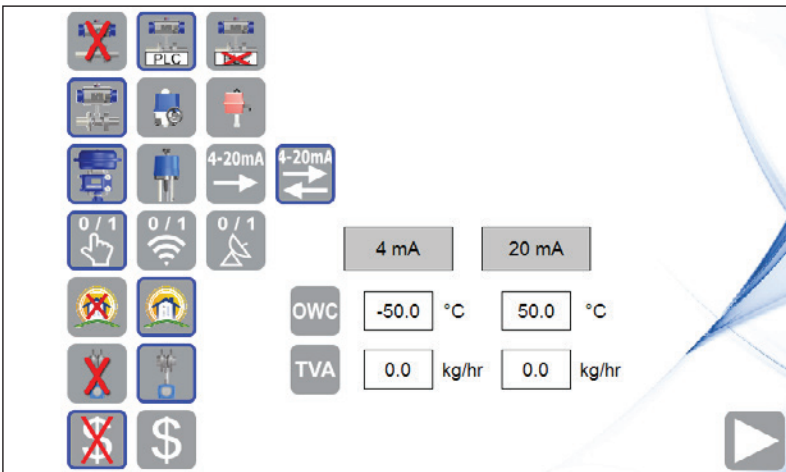

Fig. 31

A continue button will appear after system configuration which will navigate to the logged energy data for the Spirax EasiHeat™ system, press the continue button to navigate to the energy set-up page.

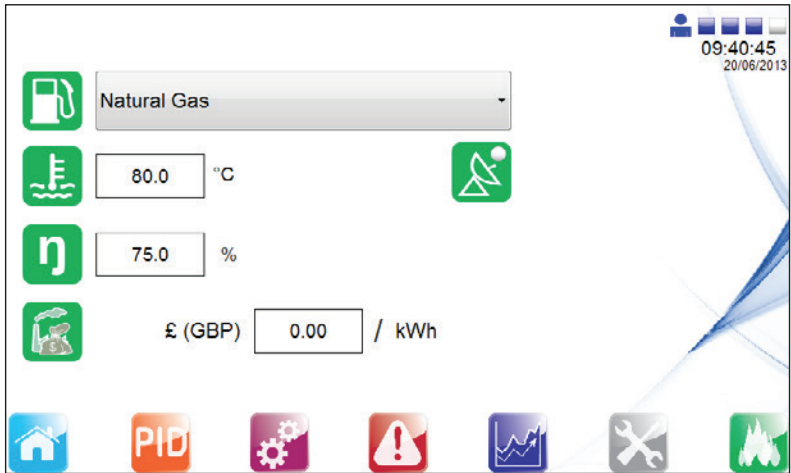

Fig. 32

Accurately enter specific energy data to ensure valid energy data can be calculated.



Boiler fuel properties - Selected via the drop down menu



Boiler feedwater temperature



Boiler efficiency



Cost per unit of fuel



Override energy set points with BACnet set points

In addition enter the custom fuel set points by selecting the custom fuel type.

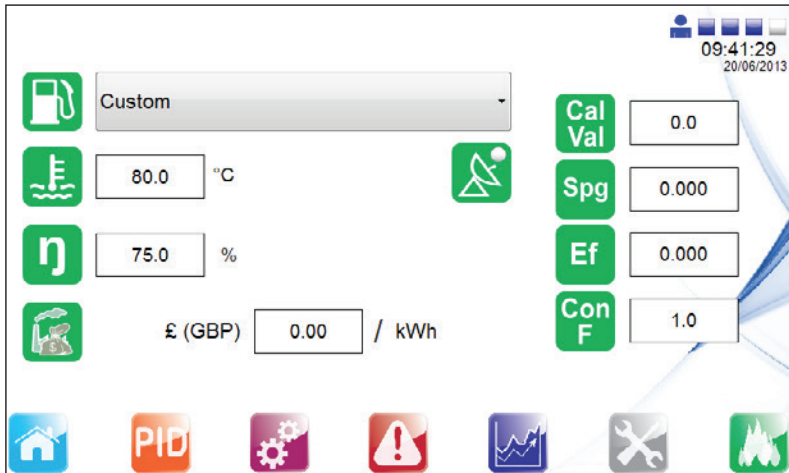





Fig. 33

Custom fuel parameters to be set:

-  Fuel calorific value
-  Fuel specific gravity
-  Fuel emission factor
-  Fuel conversion heat factor

Energy setting will not affect control process, to obtain correct values of the calculated energy, the accurate data settings are essential.

4.4 Global navigation buttons



Home
mimic



PID
set points



Settings
menu



Alarms
menu



Trend
menu



Service
menu



Energy
logging



4.4.1 Home mimic

This button will always navigate you back to the overview of the Spirax EasiHeat™ system that has been selected and configured.

From this home screen the overall status and control of the Spirax EasiHeat™ systems operation can be performed, depending on the security level access.

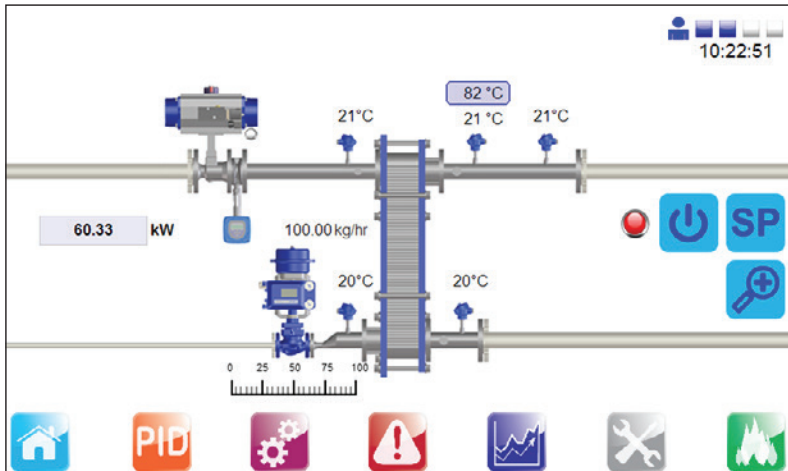

Fig. 34

Images shown below are dialogue pages that are only available for engineers access, which allow control over the valves, it is possible to enter those dialogs by pressing the screen surface at one of the unit devices (valves). This will allow the setting of the operation mode AUTO or MANUAL in which we are able to open/close the valves.

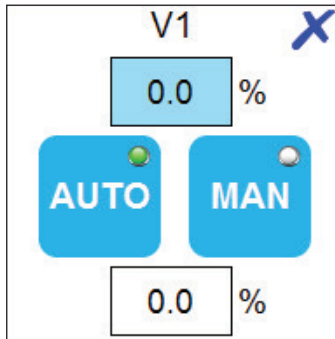

Fig. 35

V1 dialog page contains two value fields, the top one show the actual control valve position, and the lower one can be used to move the valve to requested position in manual mode.



Automatic Mode



Manual Mode

The light indicator shows what mode is selected.



PID set point

This pop-up menu allows the entry of the Spirax EasiHeat™ system target PID set point and the associated ramp-up and ramp-down time bases.

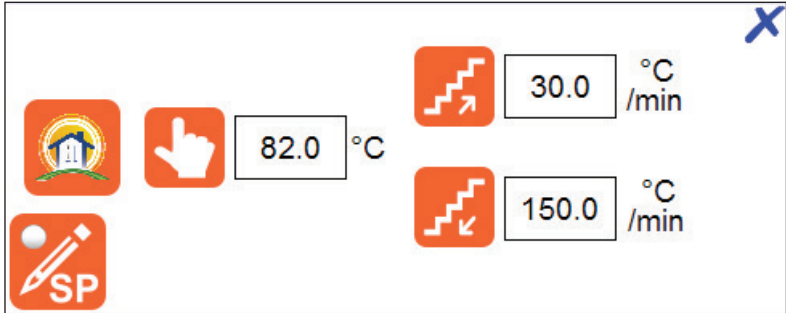

Fig. 36



Local temperature set point



Outside weather compensation set points
(Outside weather compensation only)



Ramp-up temperature set point



Ramp-down temperature set point



BACnet temperature set point override with local temperature
set point (DHW or SRDHW and BACnet selection only)



Enable control

This pop-up menu depending on the configuration, allows the user to select one of three control modes for the Spirax EasiHeat™ or view the remote or BACnet enable status. If the configuration were set to BACnet, it is possible to override the configuration and change it to local enable configuration.



Fig. 37



Spirax EasiHeat™ OFF mode



Spirax EasiHeat™ timed mode



Spirax EasiHeat™ ON mode



Timed mode set points (run schedule settings, HTG only)



Remote or BACnet EasiHeat™ enable



BACnet EasiHeat™ enable override with local Spirax EasiHeat™ enable (BACnet selection only)



Zoom

The zoom pop-up provides a more detailed view of the key process parameters.

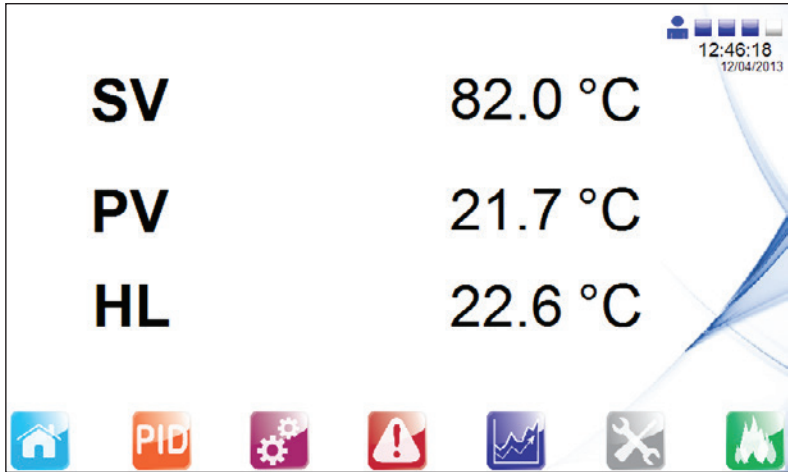

Fig. 38



4.4.2 PID set points

This page allows you to set the PID control factors (entries available only for engineers).

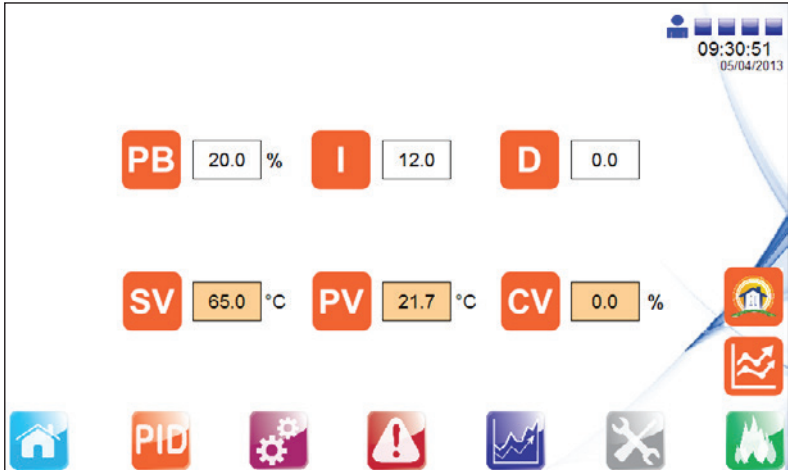

Fig. 39

- PB** Proportional band (P factor of the PID control)
- PG** Proportional gain (P factor of the PID control)
- I** Integral factor (I factor of the PID control)
- D** Derivative factor (D factor of the PID control)
- SV** Desired value (local, remote or BACnet set point)



Current value of the controlled variable (T2 temperature)



Manipulated value (valve position request)



PID real time trend page
(Allows to configure the PID set points with view of the actual signals)



Outside weather compensation set points page
(Outside weather compensation only)

The following screen is accessible from PID Loop Set Points page (available only for engineers). We are able to switch between proportional band and proportional gain. Trend shows us PID loop real time responses. The SV, PV and CV values at PID Real Time Trend are scaled to percent.

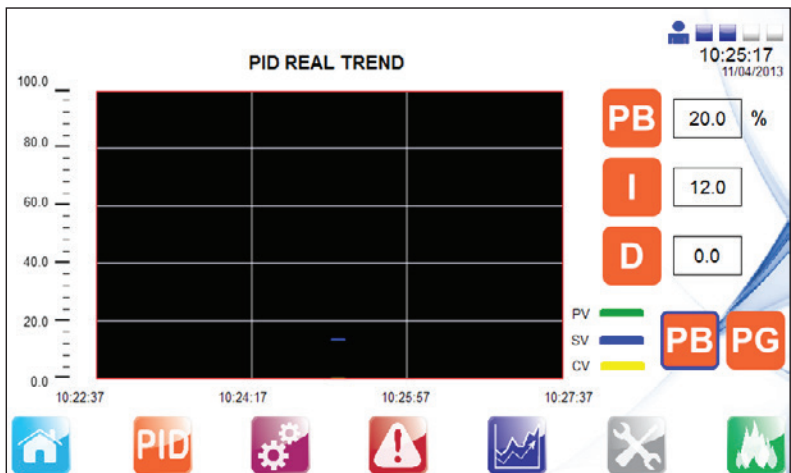

Fig. 40

The following page allows the outside weather compensation set points to be input. This can be accessed from PID Loop Set Point Page or from Set Points Dialog Page only for engineer level users.

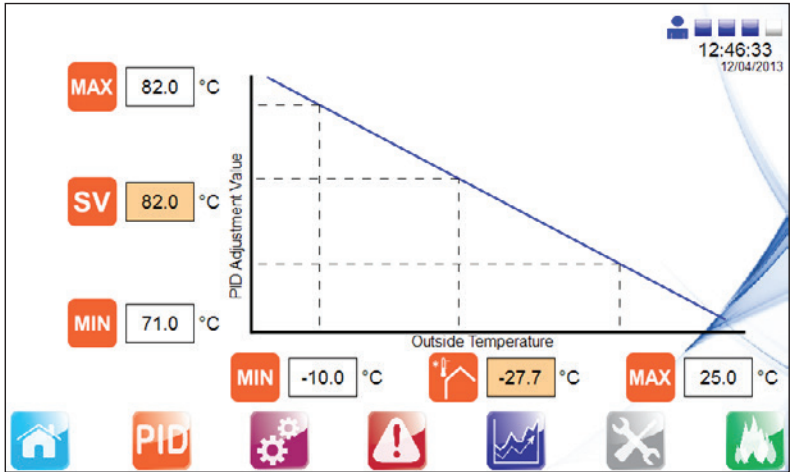

Fig. 41



4.4.3 Settings menu

The settings displayed (with blue surround) are default settings after the country flag has been selected, changes can be made if required.

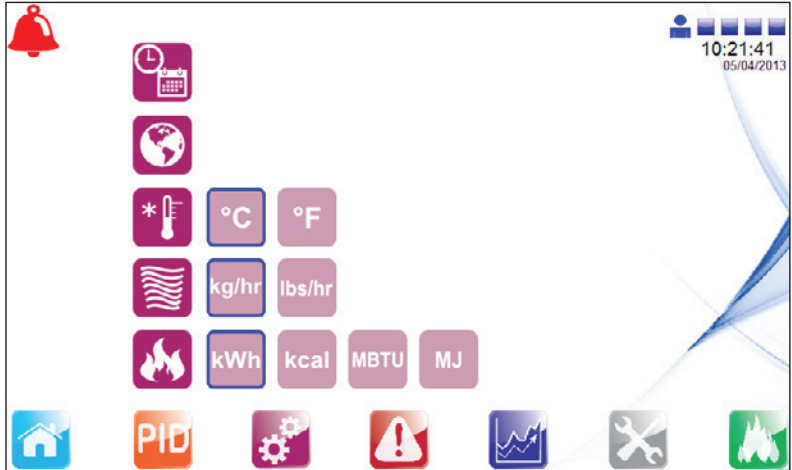

Fig. 42



Time / date configuration page



Language selection page



Temperature units selection



Flowmeter units selection (Energy monitoring only)



Energy units selection (Energy monitoring only)

There is also the possibility of changing the language (from the pre-configured options) by using the following selection menu without affecting the engineering units:



Fig. 43

In addition, engineers are able to set or change the actual time and date for PLC and HMI.

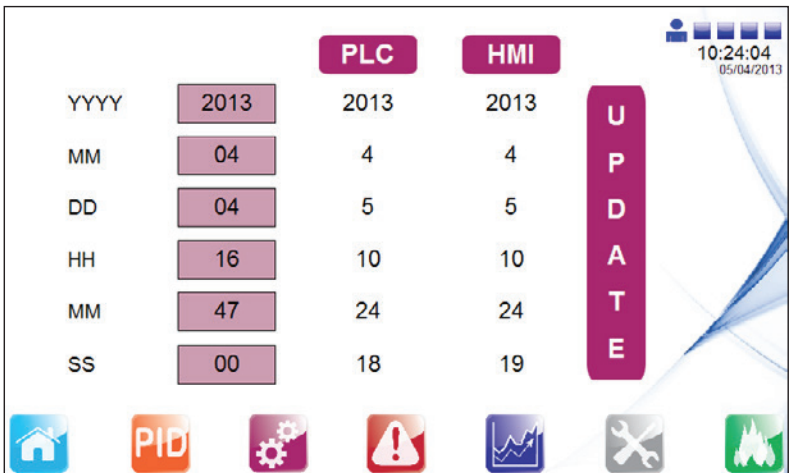

Fig. 44



4.4.4 Alarms menu

The following page shows all active alarms, an active alarm is indicated on all the mimic screens via the alarm bell in the top left hand corner of the screen.

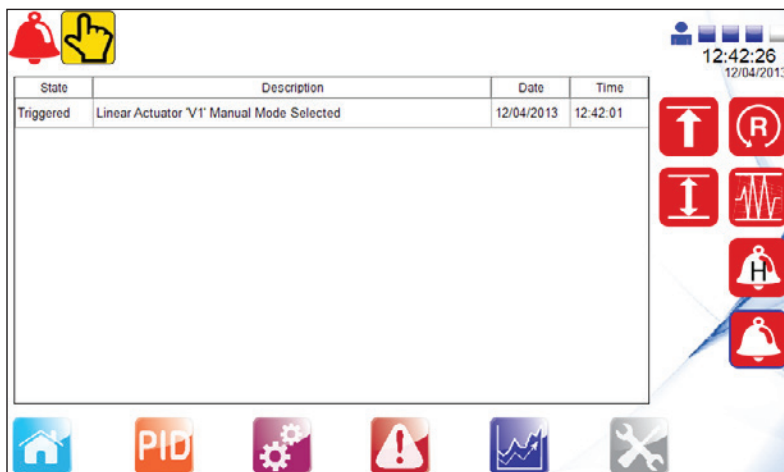
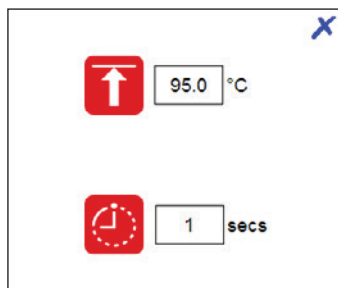

Fig. 45

There are also navigations to further alarm set point pages as well as the historical alarm list, located on the right of the display. Press each of them to view or alter.



High-limit alarm set point (PLC controlled only)



High-limit temperature set point

High-limit temperature mask time



Band alarm

10.0 °C

2 secs

5 secs

Band alarm temperature set point

Band alarm delay time set point

Band alarm reset time set point



Differential alarm (HTG only)

2.0 °C

2.0 °C

Temperature differential alarm set point

Temperature hysteresis set point



Reset high-limit alarm latch
(PLC controlled high-limit only)



Historical alarm page

Following page provides access to historical alarm list. This allows the user to view previously triggered alarms.

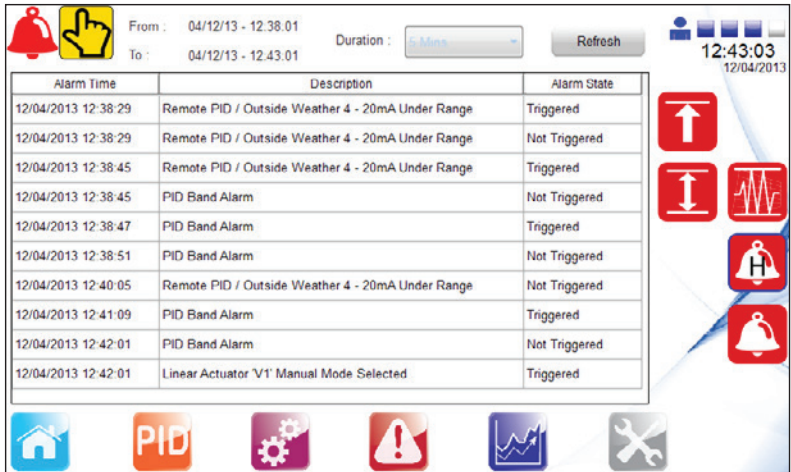

Fig. 46



Alarms indication icon



Manual alarm indication icon



Caution - high-limit setting:

- If fitted, the high-limit controller should be set at a suitable level to protect plant, process and personnel.
- Care should be taken to ensure sufficient difference between the process set point and the high-limit set point, to avoid any unwanted high limit tripping.
- Check temperature rises to set value and controls satisfactorily.
- If necessary adjust PID settings. We would strongly recommend that only a suitably trained controls engineer adjust these parameters.
- Check operation of steam traps/condensate pump.



4.4.5 Trend menu

This menu provides historical trend monitoring of the process values, useful for analysing the historical reactions of the Spirax EasiHeat™ system to process conditions.

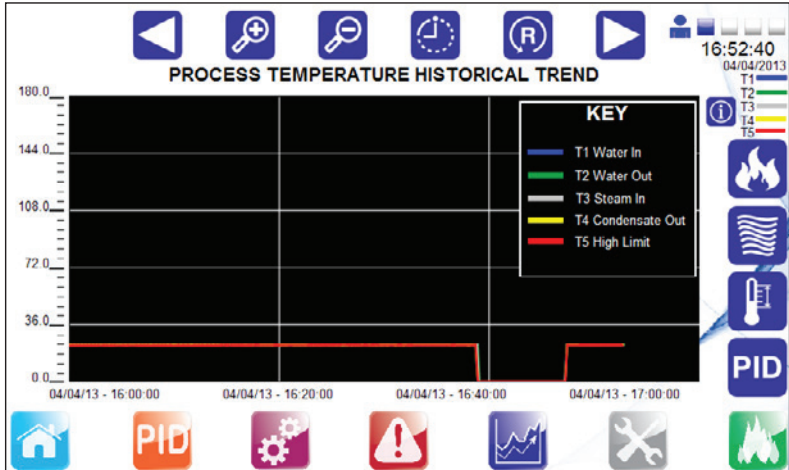

Fig. 47



Energy trend page button (energy monitoring only)



Flow trend page button (energy monitoring only)



Temperature trend page button



PID process trend page button



Scroll trend left



Zoom in trend



Zoom out trend



Move trend to actual position



Refresh trend



Scroll trend right



4.4.6 Service menu

The following page provides service information and allows engineering level users to navigate to pages containing process information.

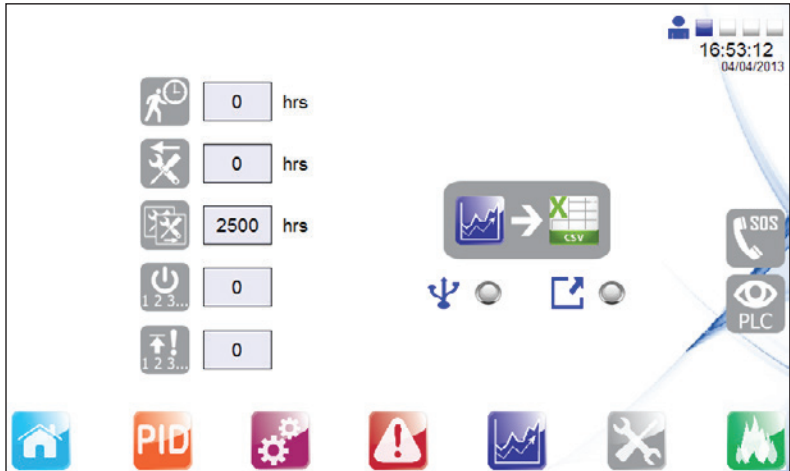

Fig. 48



Save trends to USB memory stick



This LED if green confirms that the memory stick is connected and the data format is correct (FAT32 only allowed).



This LED is switched on only during the trend dump, do not remove the memory stick before it is switched off or data may be lost.



Total unit runtime



Last service due at number of hours



Next service due at number of hours



Process enable event count



High-limit event count



Local Spirax Sarco engineer contact details dialog page



Hardware monitoring pages (input/output overview)



4.4.7 Hardware monitoring

The following pages provide only an overview of the input and outputs; it is not possible to set any set points.



Fig. 49



Fig. 50



Fig. 51

Figures 50, 51, 52 and 53 display the analogue input and output values.

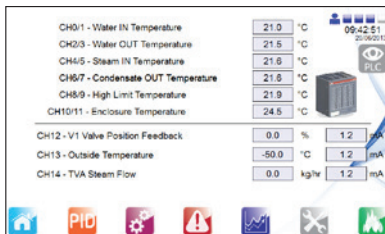

Fig. 52

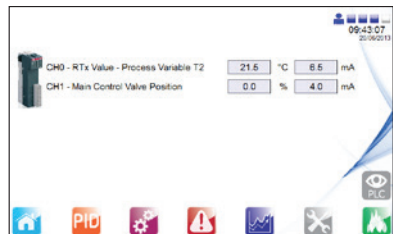

Fig. 53



Local Spirax Sarco engineer contact details dialog page

✕

Please Contact your local Spirax Sarco Agent, this can be found at www.spiraxsarco.com

Agent Name:

Spirax Sarco UK

Telephone:

00441242573342

Fig. 54



4.4.8 Energy logging

Energy monitoring pages provide the user access to view the total value of the power and carbon use, total of CO₂ emission and calculated total cost of energy that has been used. By pressing the green field underneath the 'Total Between Two Dates' allows two dates to be set for the total to be calculated between.

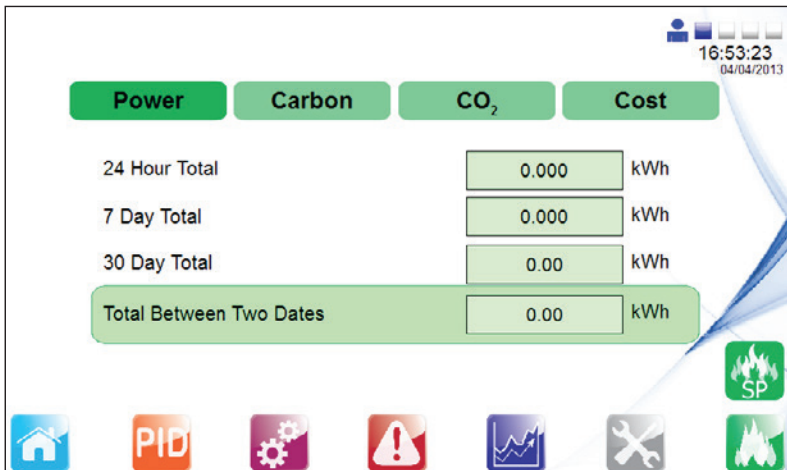

Fig. 55



Energy monitoring set points

At engineer level it is possible to access the energy page to make changes by pressing the energy monitoring set point. This will go to the energy page.

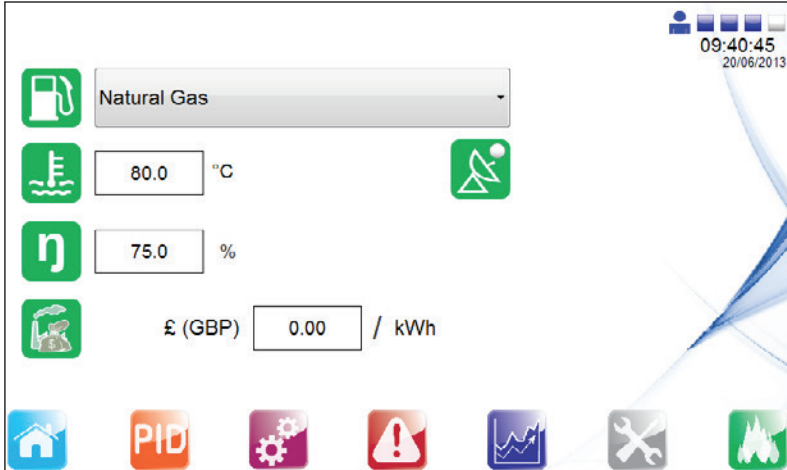

Fig. 56

To finalise the mechanical commissioning of the system:

- Open all condensate drain valves.
- Slowly open the steam inlet valve.
- Monitor the process temperature to ensure that it is within the acceptable limits.

The Spirax EasiHeat™ unit is now ready for service.

5. Fault finding

Fault	Possible cause	Remidial action
Unit does not power up	Loss of incoming supply	Check incoming supply
	Internal fuse blown	Check all mains fuses F1 - F4 and Control fuses AF1, CF1 - CF7
Loss of 24 Vdc supply	Internal fuse blown	Check all mains fuses F1 - F3 and Control fuses CF1 - CF7
	Field wiring fault	Sequentially disconnect the field wiring for all 24 Vdc supplies to see if supply is restored
Loss of 24 Vac supply	Internal fuse blown	Check all mains fuses F1 and F2 and Control fuses AF1
PT100 signal not reading correctly (T1 - T5)	Field wiring fault	Check termination of 3 wire PT100 terminats (X1 - X5) and PT100 head
	Faulty PT100	Check compensated resistance
Bypass pump does not operate	Field wiring fault	Check wiring of pump to terminals X11
	Internal fuse blown	Check mains fuse F4
Bypass valve does not operate	Field wiring fault	Check wiring of bypass valve to terminals X12
	Check setting of deviation alarm on HMI	Ensure not to set 0, the setting should be 2C
Remote set point is not showing correctly	Scaling value incorrect	Ensure that the minimum and maximum engineering units from the remote set point match those on the HMI (this data is found on the Spirax Sarco engineers 4-20 mA page)
	Polarity of 4-20 mA incorrect	Reverse polarity and wire as per electrical drawings
TVA flowmeter does not power up	Field wiring fault	Check wiring of TVA to terminal X8
	Loss of loop power	Check control fuse CF3
TVA input is not showing correctly	Scaling value incorrect	Ensure that the minimum and maximum engineering units from the TVA commissoining match those on the HMI (this data is found on the Spirax Sarco engineers 4-20 mA page)
	Polarity of 4-20 mA incorrect	Reverse polarity and wire as per electrical drawings

6. Maintenance

Note: Before actioning any maintenance observe the 'Safety information' in Section 1.

6.1 General

For maintenance of the individual components that make up the system, please see the relevant product specific IMI's for the components concerned.

6.2 High-limit device testing

The purpose of the test is to ensure that the system operates satisfactorily when required to do so.

Method:

1. High-limit set point test - The set point of the high-limit controller should be lowered, to simulate a high temperature situation. Test personnel should ensure the high-limit device operates in a satisfactory manner.

2. Electrical power failure test - The unit should be turned off at the PLC controller switch to simulate power failure. Examination should be made to ensure the high-limit system has switched to its fail-safe mode, isolating the primary steam supply.

Frequency

It is essential that a competent person tests the high-limit device on a frequent basis. Intervals between tests should not exceed a six month period.

We do not recommend the installation of a self-acting high-limit control to the Spirax Easiheat™ system.

6.3 Scale formulation

Within open systems, where there is continual make-up water, there is a risk of scale formation. The extent of the scale will depend largely upon the water quality, which varies greatly from area to area. A test, conducted by a water treatment specialist, is recommended to determine the local water quality and whether problems are foreseen.

After extended service, the plate heat exchanger can be easily dismantled for cleaning. If scale becomes a persistent problem, regular chemical cleaning should be considered. ¾" ports are available on the secondary inlet and outlet piping to allow easy connection for CIP 'Clean in Place' apparatus. It should be noted that raising the steam pressure could result in an increase of scaling.