

EasiHeat Installation and Maintenance Instructions

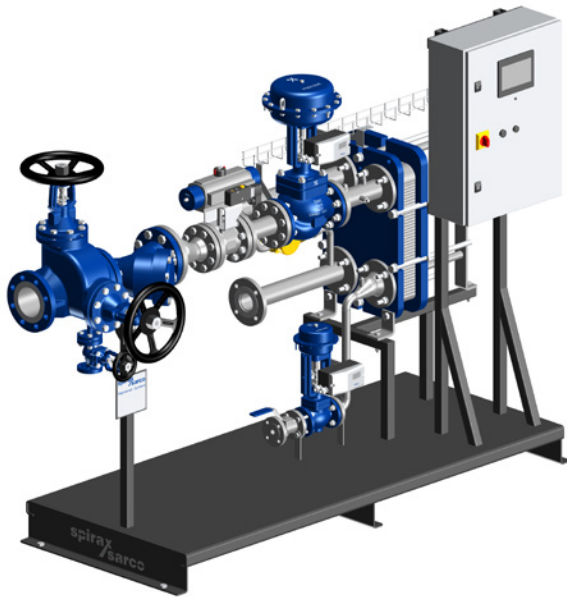

EasiHeat Dual Control System



EasiHeat Steam Control System

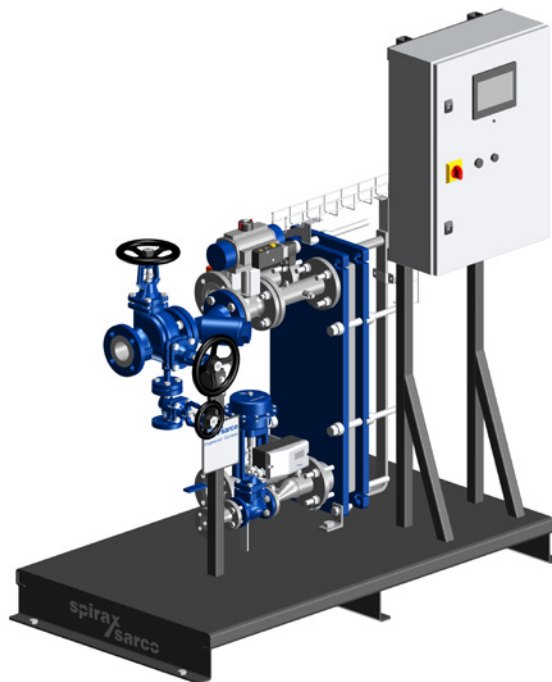

EasiHeat Condensate Control System

Contents

| | |
|---|-----------|
| 1. Safety information | 3 |
| 2. General product information | 8 |
| 2.1 Description | |
| 3. Installation | 10 |
| 3.1 Steam and condensate connections | |
| 3.2 Steam and condensate connections | |
| 3.3 Air supply | 11 |
| 3.4 Electrical supply | |
| 3.5 Electrical specifications | 12 |
| 4. Commissioning | |
| 4.1 Pre-commissioning inspection (initial start-up) | 15 |
| 4.2 Commissioning procedure | |
| 4.3 Flow meter commissioning procedure | 16 |
| 4.4 HMI commissioning | 18 |
| 4.5 Start-up procedure | 21 |
| 4.6 Shutdown | 22 |
| 5. Fault finding | 23 |
| 6. Maintenance | |
| 6.1 General | |
| 6.2 High-limit device testing | 25 |
| 6.3 Scale formulation | |
| 6.4 Local isolator | |
| 6.5 Batteries/Maintenance | 26 |
| 6.6 Functional test of safety components | 27 |
| 6.7 Smart fuse | |
| 7. Component map | 28 |
| 7.1 Component naming convention | |
| 7.2 Component definitions | 29 |

1. Safety information

In addition to putting your personnel at risk of death or serious harm, failure to comply with the instructions, recommendations and guidance set out in this document may jeopardise your warranty rights. Further, use of the product(s) otherwise than in accordance with this document will be undertaken entirely at your own risk. To the fullest extent legally permitted, Spirax Sarco excludes all responsibility and liability for any and all loss or damage caused in the event that the practices and procedures detailed in this document have not been followed.

Safe operation of these products can be guaranteed only if they are properly installed, commissioned and maintained by a qualified person (see Section 1.11) in compliance with the related operating instructions. General installation and safety instructions for pipeline and plant construction and also the proper use of tools and safety equipment must also be complied with.

General safety notes

This document refers only to the mechanical installation and commissioning of the EasiHeat system should be used in conjunction with the relevant IMIs for the other system components and supplementary safety information for all the system components.

Lifting

The EasiHeat system should be lifted by a suitable forklift truck, from the base, placed in position and securely bolted to the floor when required.

The customer is responsible for the safe lifting of the EasiHeat system.



**Caution
or
Warning**

Do not lift the EasiHeat system by any other part except from the base.



Note: always leave sufficient space around the system for future maintenance operations.

Warnings

1. The unit is designed and constructed to withstand the intensity of work in ordinary use.
2. Use of the product for any other purpose, or failure to install the product in compliance with these Installation and Maintenance Instructions, may damage the product and also cause serious injuries to operating personnel.
3. Before carrying out any installation and maintenance procedure, always check that all primary steam, condensate and water return lines on the secondary have been isolated.
4. Make sure that residual pressure in the system and in pipework has been vented to atmospheric level.
5. To avoid the risk of burns, allow parts to cool before carrying out any type of operation.
6. Always wear suitable protective clothing before carrying out any installation or maintenance activity.

1.1 Intended use

Referring to the installation and maintenance instructions and the nameplate of the unit and the Technical Specifications, check that the product is suitable for intended use/application.

EMEA - The EasiHeat heating system complies with the requirements of the EU Pressure Equipment Directive/UK Pressure Equipment (Safety) Regulations and is   marked. For any product specific PED categorisation that is required for this unit or products used in the make-up of the unit please contact Spirax Sarco directly.

- i) The product has been specifically designed for use on steam and water belonging to Group 2 of the above-mentioned Pressure Equipment Directive.
- ii) Check suitability of material, pressure and temperature and related maximum and minimum values. If the maximum operating limits of the product are lower than those of the system in which it to be inserted, or if malfunction of the product could generate dangerous overpressure or overtemperature, always insert a safety device in the system to prevent exceeding of such limits.
- iii) Determine the correct installation position and direction of flow of fluids.
- iv) The product is not designed to withstand external stresses induced by the system in which it is fitted. The installer is responsible for taking into account such stresses and for adopting adequate precautions to reduce these to a minimum.
- v) Prior to installation, remove protective covers from all connections and also protective film and packaging elements.

1.2 EU Pressure Equipment Directive/UK Pressure Equipment (Safety) Regulations classification

The EasiHeat series are classified as assembly according the EU Pressure Equipment Directive/UK Pressure Equipment (Safety) Regulations:

| Product | Fluid Group | Category |
|--|-------------|----------|
| EasiHeat DHW and HTG | 2 | I |
| EasiHeat DHW and HTG (T10 HEX with 46+ plates) | 2 | II |

For the category of bespoke units, refer to the “EC Declaration of Conformity” supplied with the product. Other component parts of the assembly comply with the relevant European Directives, where necessary. Please refer to specific component literature for further details.

1.3 Access

Ensure safe access and, if necessary, a safe working platform (suitably guarded) before attempting any work on the product. Arrange suitable lifting gear if required.

1.4 Lighting

Ensure adequate lighting, particularly where detailed or intricate work is required.

1.5 Hazardous liquids or gases in the pipeline

Take into account what is currently in the pipeline or what may have been in the pipeline at some previous time. Consider: flammable materials, substances hazardous to health, extreme temperatures.

1.6 Hazardous environment around the product

Consider: areas with a risk of explosion, lack of oxygen (e.g. tanks, pits), dangerous gases, extreme temperatures, hot surfaces, fire hazards (e.g. during welding), excessive noise, moving machinery. The place of installation of the assembly must be equipped with the fire-prevention devices required by current regulations.

1.7 The system

Consider the effect of the work to be carried out on the entire system. Consider whether the action proposed (e.g. closing of isolating valves, electrical isolation) may put any other part of the system or personnel at risk.

Hazards may include isolation of vents or protective devices or the rendering ineffective of controls or alarms. Ensure isolating valves are opened and closed gradually to avoid shocks to the system.

| | |
|---|---|
|  | 1.8 Pressure systems Ensure that any pressure is isolated and safely vented to atmospheric pressure. Consider double isolation (double block and bleed) and locking or labelling of closed valves. Do not assume that the system has depressurised even when the pressure gauge indicates zero. |
| | 1.9 Temperature Allow time for temperature to normalise after isolation to avoid the risk of burns and consider whether protective clothing (including safety glasses) is required. If there is a possibility of heated water coming directly/indirectly in contact with personnel, a high limit must be fitted to mitigate the risk of scalding and appropriate risk assessment conducted |
| | 1.10 Hard water Water supplied to the EasiHeat is recommended to be less than (<) 200ppm |
| | 1.11 Protective bonding The EasiHeat system and nearby metallic items within 2.5m meters should be all connected to the same common earth. |
| | 1.12 Electrical Hazard The EasiHeat system's panel contains hazardous voltages. Some maintenance operations may require the panel being energized and open. These maintenance actions may only be undertaken by a suitably qualified and competent person. |
| | 1.13 Legionella Legionella bacteria presents a risk in any hot water system, appropriate measures should be taken in line with national guidance to manage this risk. Features are available with this product to enable monitoring to reduce the risk. |

1.14 Tools and consumables

Before starting work, make sure you have suitable tools and/or consumables on hand. Use only genuine Spirax Sarco replacement parts.

1.15 Protective clothing

Consider whether you and/or others require protective clothing to protect against hazards, such as chemicals, high/low temperatures, radiation, noise, falling objects and danger to eyes and face.

1.16 Permits to work

All work must be carried out or supervised by a suitably competent person. Installation and operating personnel should be trained in correct use of the product according to the Installation and Maintenance Instructions. Any formal work permit system adopted must be complied with. Where no such system is applied, a person responsible should be informed of progress of the work and, where necessary, an assistant with primary responsibility for safety should be appointed. Post "warning signs" if necessary.

1.17 Handling

Manual handling of large and /or heavy products may involve a risk of injury. Lifting, pushing, pulling, carrying or supporting a load by bodily force may cause injury, particularly to the back.

You are advised to assess the risks, taking into account the task, the individual, the load and the working environment and use appropriate handling methods according to the circumstances of the work to be carried out.

Note: if it is necessary to use slings for lifting, it is good practice to fit these around the plate of the base unit to avoid damage to the unit.

1.18 Storage

Note: If the EasiHeat cannot be installed and put into operation immediately upon receipt at the jobsite, certain precautions are necessary to prevent deterioration during storage.

Responsibility for integrity of the heat exchangers must be assumed by the user. Spirax Sarco will not be responsible for damage, corrosion or other deterioration of heat exchanger equipment during transit and storage.

The following suggested practices are provided solely as a convenience to the user, who shall make their own decision on whether to use all or any of them.

- On receipt of the EasiHeat, inspect for shipping damage to all protective covers. If damage is evident, inspect for possible contamination and replace protective covers as required. If damage is extensive, notify the carrier immediately and Spirax Sarco.
- If the EasiHeat is not to be placed in immediate service, take precautions to prevent rusting or contamination.
- Store under cover in a heated area, if possible. The ideal storage environment for EasiHeat and accessories is indoors, above grade, in a dry, low humidity atmosphere which is sealed to prevent entry of blowing dust, rain or snow. Maintain temperatures between 0 °C and 40 °C (32 °F and 104 °F) and humidity at 40% relative humidity or lower.

Note: Ambient temperature of the place where the unit will be installed must be above 0 °C (32 °F) and below 40 °C (104 °F).

1.19 Freezing

Precautions must be taken to protect products that are not self-draining against frost damage in environments where they may be exposed to temperatures below freezing point.

1.20 Disposal

As the product may contain PTFE and Viton, particular precautions must be adopted to avoid potential risks for health caused by decomposition or combustion of such materials. Unless otherwise indicated in the installation and maintenance instructions with regard to the materials of the seals, this product can be recycled and it is considered that no environmental risk exists deriving from disposal thereof provided that suitable precautions are adopted. However, its components can be checked to verify the possibility of safe disposal.

PTFE:

- This material can be disposed of only using approved systems and never in incinerators.
- PTFE waste to be disposed of must be stocked in separate containers, must never be mixed with other waste and must be sent directly to a landfill.

Viton:

- VITON waste can be sent directly to landfills when permitted and accepted by local and national regulations.
- VITON components may also be incinerated but a scrubber must be used to remove the hydrogen fluoride developed by the product, carrying out this procedure in accordance with local and national regulations.
The components are insoluble in aquatic media.

Electrical:

Unless otherwise stated, the electrical components within this product are recyclable and no ecological hazard is anticipated with its disposal providing due care is taken. The product should be recycled in line with local legislation. An overview of the structure of the control panel is available in the supplied wiring diagram.

Please visit the Spirax Sarco product compliance web pages

<https://www.spiraxsarco.com/product-compliance>

for up to date information on any substances of concern that may be contained within this product.

Where no additional information is provided on the Spirax Sarco product compliance web page, this product may be safely recycled and/or disposed providing due care is taken.

Always check your local recycling and disposal regulations.

1.21 Return of products

Customers and stockists are reminded that, under EC Health, Safety and Environment Law, when returning products to Spirax Sarco, they must provide information regarding any hazards and precautions to be taken due to contamination residues or mechanical damage which may represent a risk to health, safety or the environmental. This information must be provided in writing, including Health and Safety datasheets relating to any substances identified as hazardous or potentially hazardous.

Notes:

For additional information about any particular product used in the construction of this unit see the relevant product specific Technical Information (TI-P565-08) sheet.

Copyright © Spirax-Sarco Limited 2023

All rights reserved

Spirax-Sarco Limited grants the legal user of this product (or device) the right to use the Work(s) solely within the scope of the legitimate operation of the product (or device). No other right is granted under this licence. In particular and without prejudice to the generality of the foregoing, the Work(s) may not be used, sold, licensed, transferred, copied or reproduced in whole or in part or in any manner or form other than as expressly granted here without the prior written consent of Spirax-Sarco Limited.

2. General product information

2.1 Description

EasiHeat systems use steam to provide accurate heating of low temperature hot water (HTG), domestic hot water (DHW) or hot water for processes. Systems can be sized for any heating duty from 70 kW to approximately 3.5 MW and are supplied fully assembled and pressure tested, ready for installation.

The core Easiheat system is available in 3 different basic configurations:

- Steam Control
- Condensate Control
- Dual Control

The innovative dual control system allows control of temperature and pressure within the heat exchanger to allow more of the available energy to be transferred to the heated media.

Additional feature and options are available for each core configuration, such as high limit valves, isolation and metering options. These options are detailed in section 2.2.

The EasiHeat unit consists of the following core items (refer to Figure 1):

- A** Steam plate heat exchanger, type T6-P, TS6-M, T8-M, or T10-M
- B** Pneumatically or Electrically actuated steam control valve and positioner
- C** PLC Controller and sensors
- D** Condensate removal solution
- E** Pipeline ancillaries
- F** Lockable Isolator

For a detailed list of equipment and specifications, refer to the PandID and documentation provided.

For additional information about any particular product used in the construction of these units see the relevant product specific Technical Information (TI) sheet.

For further technical information regarding the EasiHeat system please refer to TI-P565-08 and IM-P565-10.

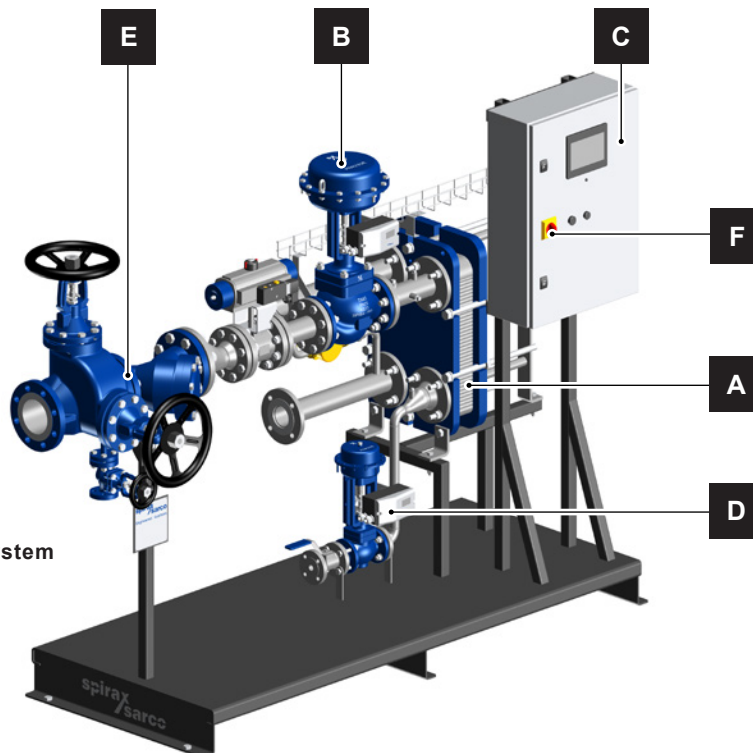

Fig. 1a EasiHeat Dual Control System

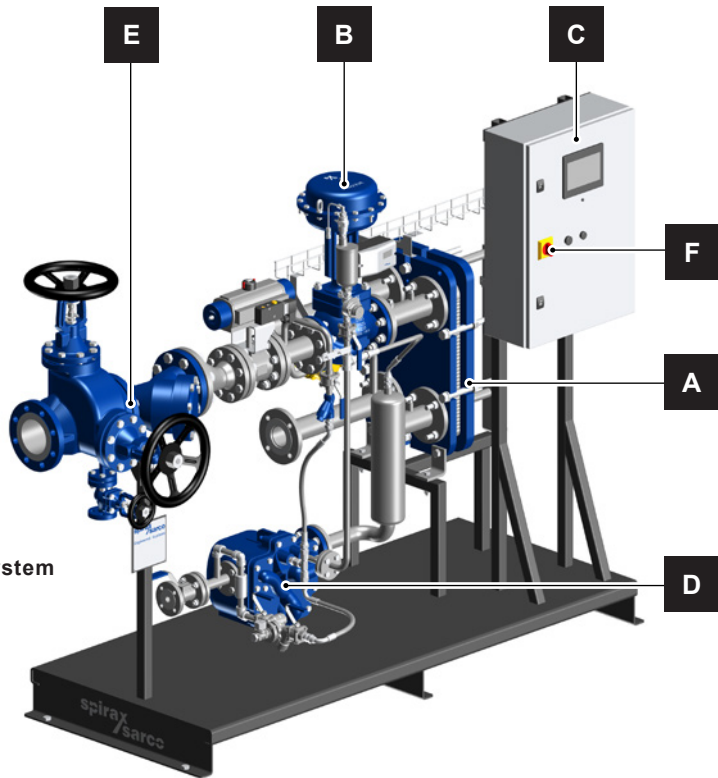

Fig. 1b EasiHeat Steam Control System

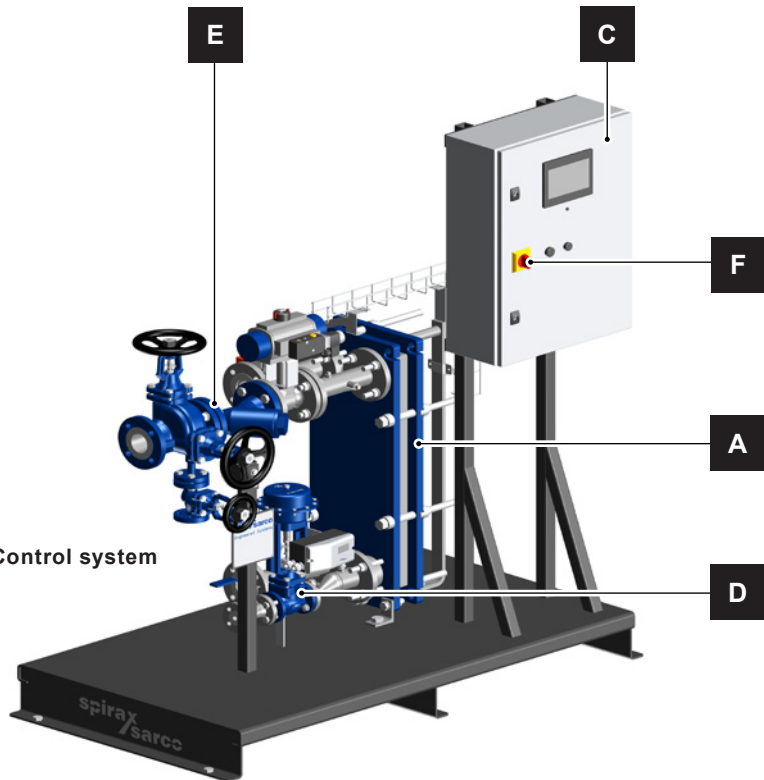
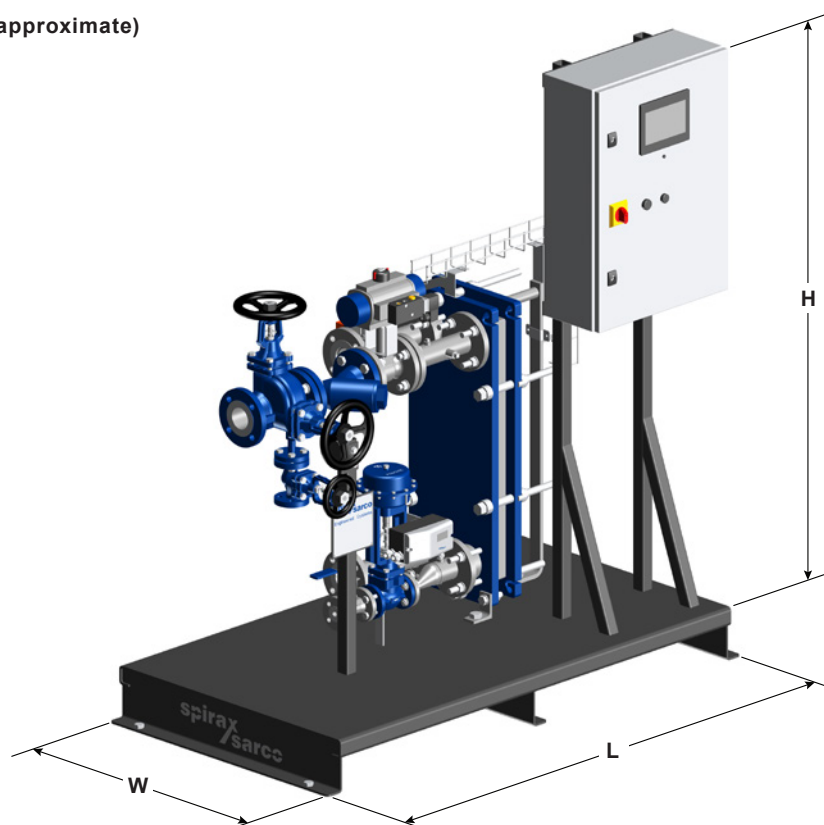

Fig. 1c EasiHeat Condensate Control system

3. Installation

3.1 Dimensions (approximate)



| Metric | | Maximum dimensions (mm) | | | Piping connections | | |
|-------------|-----------------|-------------------------|------|-----|--------------------|-------|------------|
| Type | Valve actuation | H | L | W | Steam | Water | Condensate |
| EHDSC | EL or PN | 1760 | 1950 | 850 | DN65 | DN65 | DN25 |
| EHDDC | EL or PN | 1760 | 2320 | 950 | DN65 | DN65 | DN15 |
| EHHCC (T6) | EL or PN | 1760 | 1480 | 870 | DN50 | DN50 | DN15 |
| EHHCC (T8) | EL or PN | 1760 | 1950 | 850 | DN80 | DN80 | DN20 |
| EHHCC (T10) | EL or PN | 1760 | 1760 | 870 | DN100 | DN100 | DN25 |

| Imperial | | Maximum dimensions (inches) | | | Piping connections | | |
|-------------|-----------------|-----------------------------|----|----|--------------------|-------|------------|
| Type | Valve actuation | H | L | W | Steam | Water | Condensate |
| EHDSC | EL or PN | 70 | 77 | 34 | 2½" | 2½" | 1" |
| EHDDC | EL or PN | 70 | 92 | 38 | 2½" | 2½" | ½" |
| EHHCC (T6) | EL or PN | 70 | 59 | 35 | 2" | 2" | ½" |
| EHHCC (T8) | EL or PN | 70 | 77 | 34 | 3" | 3" | ¾" |
| EHHCC (T10) | EL or PN | 70 | 70 | 35 | 4" | 4" | 1" |

* EHHDC has the same dimensions as the EHHCC versions

Options selected may impact overall dimensions.

EasiHeat

spirax
sarco

3.2 Steam and condensate connections

It is important that the steam supply (and compressed air if pneumatic actuation is selected) to the EasiHeat unit is supplied as dry and as clean as possible, in accordance with good steam engineering practice.

It should also be ensured that all connecting pipework is stress free and adequately supported.

The steam supply should always be maintained at the specified design pressure and temperature for the unit. The EasiHeat must not operate above the maximum steam pressure and temperature indicated on the name-plate attached to the plate heat exchanger.

The installation of an appropriately sized safety valve, to protect the pressure equipment on either the hot or cold side of the plate heat exchanger, should be fitted if required.

Spirax Sarco supplies a range of traps, strainers, separators, safety valves and pressure reducing equipment.

3.3 Air Supply

If a pneumatic control system is installed, connect a compressed air supply 2 to 6 bar g (29 psi g to 87 psi g) to the pressure regulator mounted on the control valve.

If the PN3000 actuator has been fitted the maximum air pressure is 3 bar g.

| | |
|---|--|
|  | <p>Please refer to documentation for the pneumatic control valve when lifting.</p> <p>During lifting, take into account the high centre of gravity of the unit and adopt all the necessary precautions to avoid accidental tipping over of the unit.</p> |
|---|--|

3.4 Electrical Supply

All electrical wiring and connections should be carried out in accordance with National Regulations.

A lockable isolator/switch disconnect should be fitted adjacent to the unit.

Mains supply is directly connected to the primary side of the incoming control panel isolator (shown with the IP2X cover removed) and main earth terminal as shown in Figure 2.

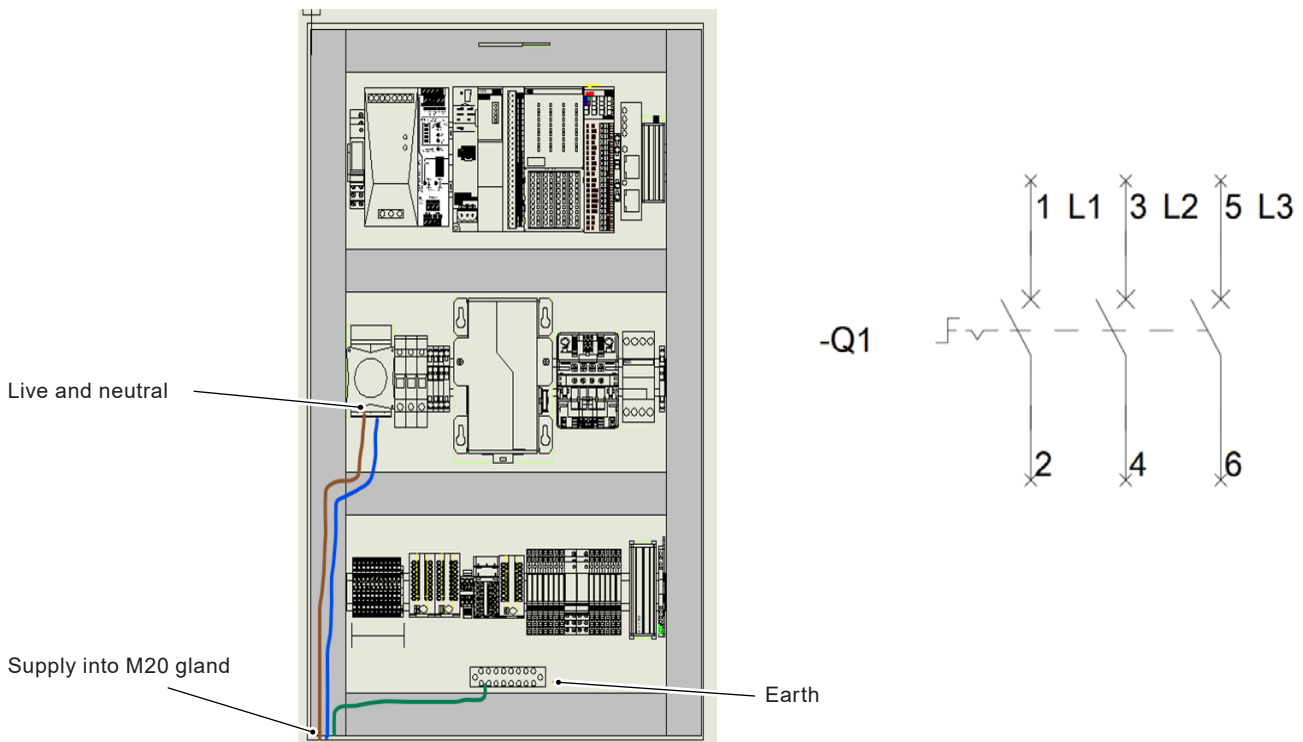

Fig. 2

3.5 Electrical specifications

3.5.1 Power supply

| | | |
|--|---|------------------|
| Electrical supply requirements | 110 Vac/60 Hz | |
| | 230 Vac/50Hz | |
| Power consumption | 400 W | |
| Maximum supply conductor dimensions | 16 mm ² | |
| Maximum current draw | 1.6A | |
| Fuses | Panel Fan (F1) | 0.5A (Slow blow) |
| | PLC/HMI/Comms (F3) | 3A (quick blow) |
| | Steam Control Valve (F4) and Split range steam control valve/ Condensate control valve analog position feedback (F5) | 5A (slow blow) |
| | F6 24V 4-20 mA | 0.5A (Slow blow) |

The following are available for customer connection to the EasiHeat system if required:

3.5.2 Customer connections

Volt free contacts

| Terminal designation | Description | Type |
|----------------------|--|-----------------------|
| RHL | E-stop circuit alarm | N/O volt-free contact |
| RRM | Run BMS contact | N/O volt-free contact |
| RBX4 | TA21 Water outlet temperature retransmission | 4-20 mA Analog Input |

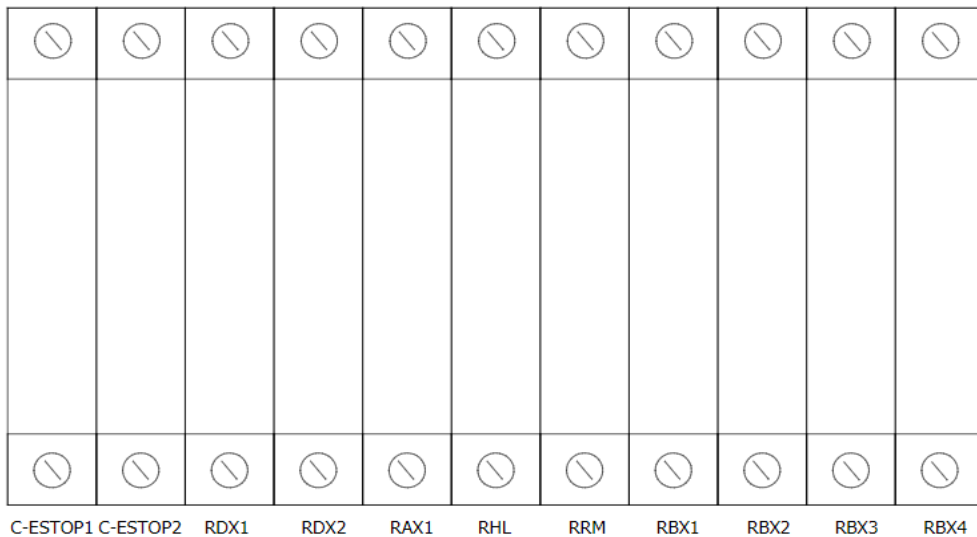

Fig. 3

Remote operation and retransmission connections

| Terminal designation | Description | Type |
|----------------------|---|----------------------|
| RDX1 | Remote stop request | 24 Vdc coil |
| RDX2 | Remote start request | 24 Vdc coil |
| RDX2 | Remote start request | 24 Vdc coil |
| RBX1 | VB31 steam control valve retransmission | 4-20 mA Analog Input |
| RBX2 | VB32 auxiliary control valve/VB41 condensate control valve retransmission | 4-20 mA Analog Input |
| RBX3 | Hot Water setpoint transmission | 4-20 mA Analog Input |
| RBX4 | TA21 Water outlet temperature retransmission | 4-20 mA Analog Input |

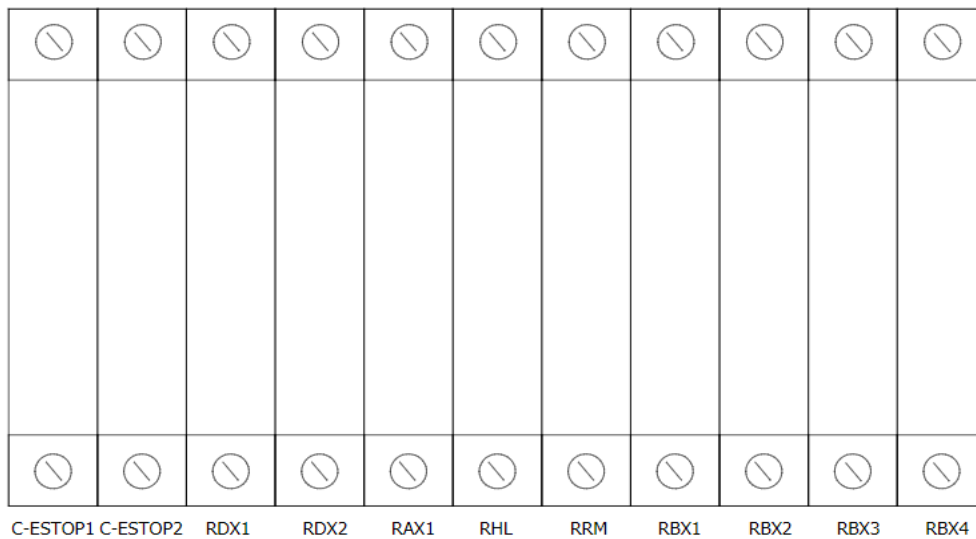

Fig. 4

M12 Sensor/Component connector layout

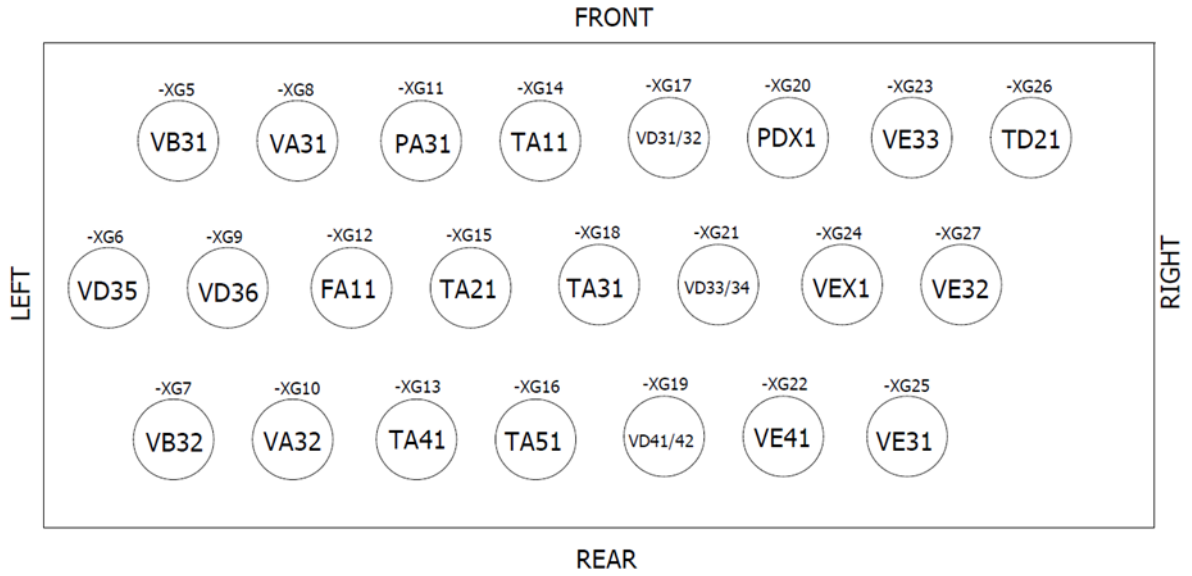

Fig. 5

4. Commissioning

For correct commissioning, we recommend the service and support of a Spirax Sarco engineer. Please contact your local Spirax Sarco representative for more details.

4.1 Pre-commissioning inspection (initial start-up)

- Ensure all bolts and fasteners have been correctly tightened before commissioning.
- Most of the new installations during the construction of pipelines and the installation of the system, may inadvertently collect dirt particles inside the pipes. It is essential to carefully remove any residual impurities and dirt in them before starting the commissioning.
- Check that all the manual isolating valves (on primary steam, on condensate removal, on water side are closed).
- Clean the filters upstream of the regulation valves.
- Check that the steam and water design conditions do not exceed the rated values of the unit.
- Check that the supply steam line is properly pressurised and has been drained/ vented.
- Make a double check to verify that all connections to steam, condensate and water lines have been made correctly.
- Check the air supply of the filters/reducers of the valves (actuated pneumatically where established) and that it complies with the system requirements.

4.2 Commissioning procedure

1. Dry commissioning valve stroke check - An initial valve stroke check should be carried out to ensure free movement of the valve stem.
 - For the electric actuated control valve, please see IM-P713-01.
 - For the pneumatic actuated control valve, please see IM-P706-05
2. Open the secondary (cold side) isolating valves downstream of the EasiHeat.
3. Start the main secondary water circulating pump(s) if fitted.
4. Check and confirm there is secondary water circulation through the EasiHeat.
5. If the circulation is okay, switch on the main power to the control panel (local isolator).
6. Turn the control panel isolation switch to 'ON'.
7. Commission the flowmeter (if fitted) see section 4.3.
8. To finalise the mechanical commissioning of the EasiHeat system:
 - 8.1. Open all condensate drain valves
 - 8.2. Slowly open steam inlet valve
 - 8.3. Monitor the process temperature to ensure that it is within the acceptable limits

4.3 Flow meter commissioning procedure

4.3.1 Operating and display elements

- 1 Switching status LED for OUT1
- 2 Switching status LED for OUT2
- 3 Process value in the indicated unit of measurement *
- 4 4-digit alphanumeric display
- 5 Keys for changing views and parameter setting
- 6 Enter button for entering settings.

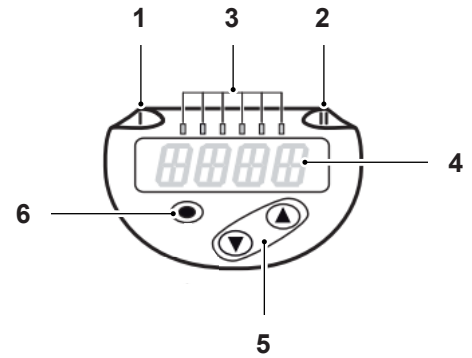

Fig. 6

1, 2, 3 Indicator LED's

- LED 1 = switching status OUT1 (lights if output 1 is switched)
- LED 2 = process value in the indicated unit of measurement (% , m/s, l/min, m3/h, C, 103))
- LED 3 = switching status OUT2 (lights if output 2 is switched)

4: Alphanumeric display, 4 digits

Indication of the current process values in red or green characters
 Display of the parameters and parameter values

5: Buttons up [up arrow] and down [down arrow]

- Select parameter
- Change of parameter value (hold button pressed)
- Change of the display unit in the normal operating mode (Run mode)
- Lock / Unlock (buttons pressed simultaneously > 10 seconds)

6: Button [circle] = Enter

- Change from the RUN mode to the main menu
- Change to settings mode
- Acknowledge the set parameter value

4.3.1 Operating modes

The device provides three selectable operating modes for flow measurement. The operating mode must be selected at the beginning of the parameter setting

The selected operating mode has no effect on the temperature measurement, only absolute values in °C (°F) are indicated

| Operating mode [ModE] | Medium | Display unit |
|-----------------------|--------------|------------------------------------|
| REL | liquids, air | % of the taught range |
| LIQU | liquids | m/s; l/min m³/h (fps, gpm, cfm) |
| GAS | air | |

Note : A change of the operating mode leads to a restart of the device. The parameter settings are saved in the respective operating mode, i.e. when the operating mode is changed, the settings are not lost

4.3.2 Parameter setting via the device keys: Operating mode

1. Open the [INI] menu.
2. Select [ModE] and define the operating mode: [LIQU]
3. The device carries out a reboot.

Note : Operating mode [LIQU] must be selected on all EasiHeat packages.

4.3.3 Parameter setting via the device keys: Internal pipe diameter

1. Open the [INI] menu.
2. Select [diA] and define the internal pipe diameter

Note : [diA] is only available if the [GAS] or [LIQU] mode is selected.

| DN | Diameter (mm) |
|-------|---------------|
| DN50 | 54.8 |
| DN80 | 66.9 |
| DN100 | 108.2 |

The measurements above are taken in accordance with BS1600 : 1991

Commisioning of the flow meter is now complete.

4.3.4 Flowmeter orientation

If for any reason the flow meter has been or needs to be removed from the EasiHeat system it is important to understand the following::

To achieve the optimum measuring accuracy, mount the sensor in a way that the flow goes to the larger of the two key surfaces and do not go beyond the end stop."

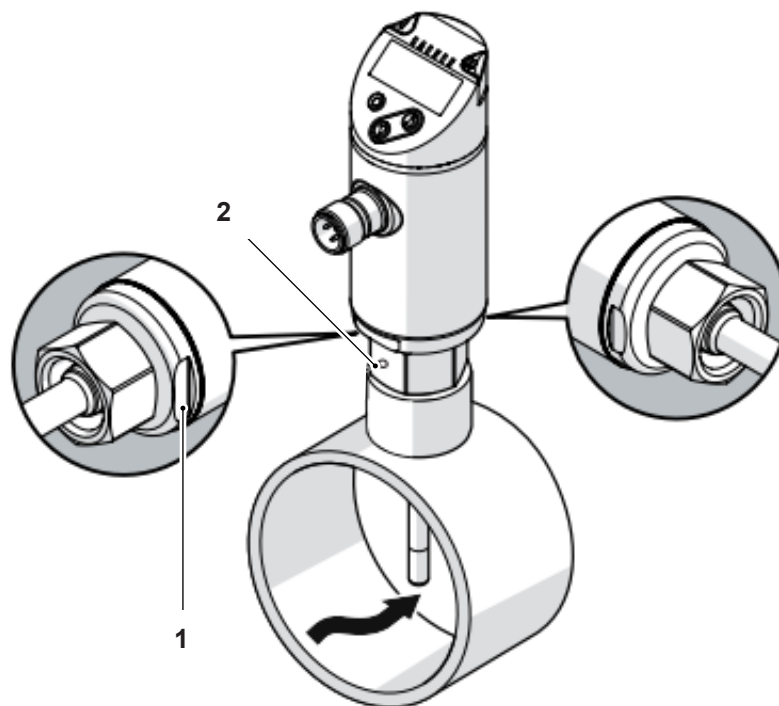

Fig. 7

4.4 HMI commissioning

Ensure that section 4.2 has been completed before continuing.

Note :

1. This stage may have been completed from factory.
2. For comprehensive detail on the start-up/running of the EasiHeat please see IM-P565-10.

3. Tap welcome screen



4. Select language

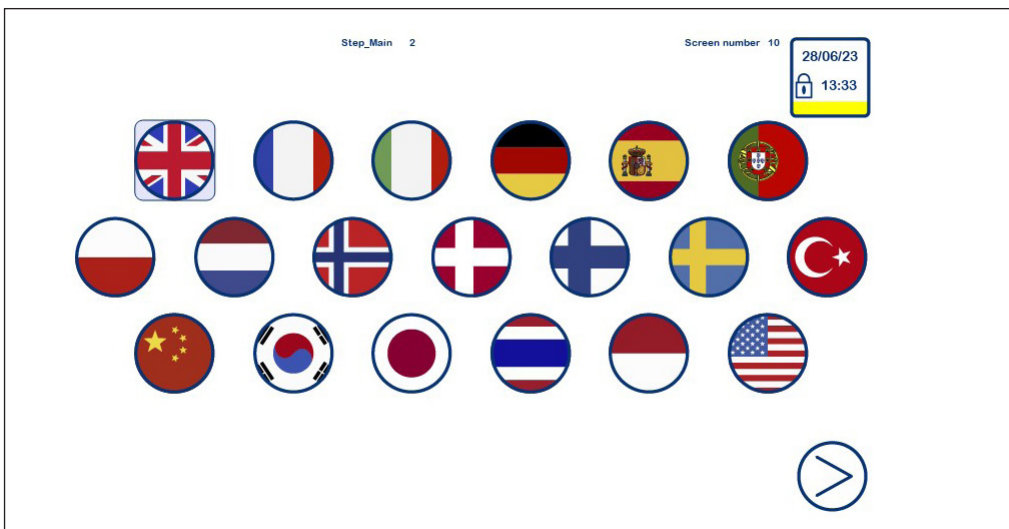

5. Select engineering units, set date and time

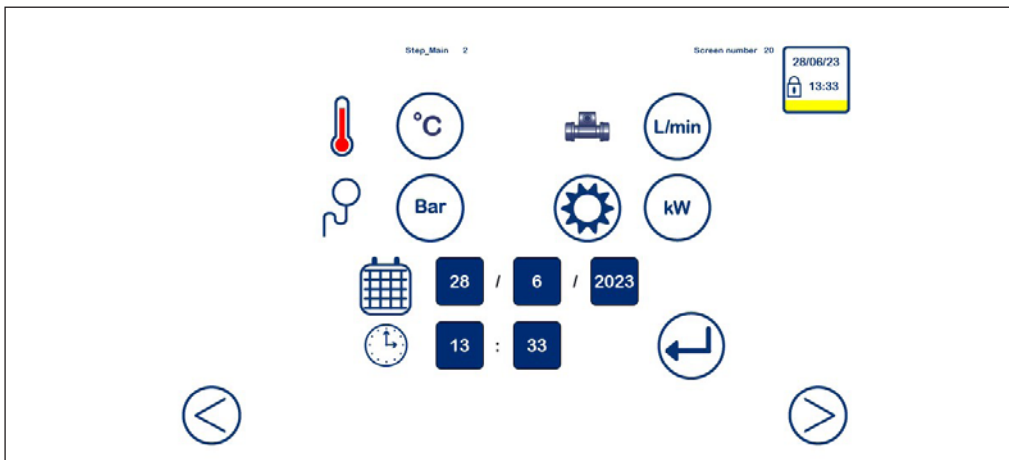

6. Insert product nomenclature from product documentation pack

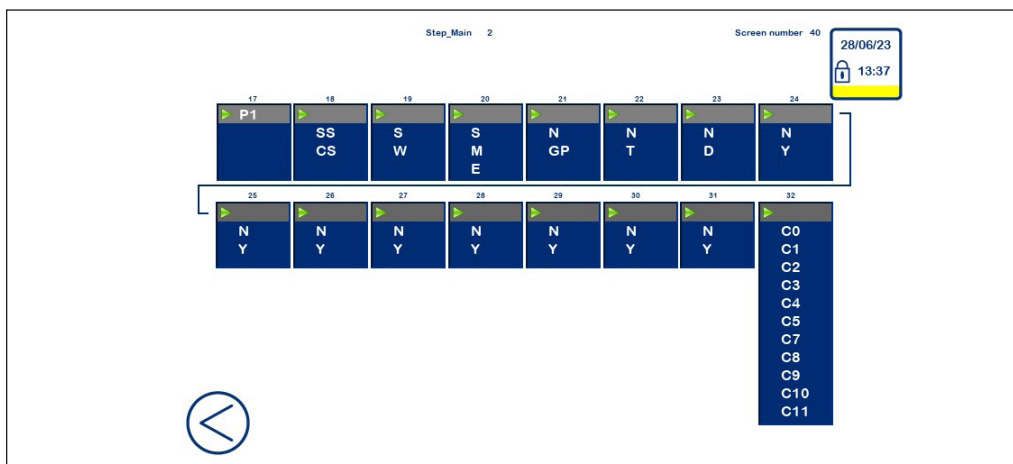
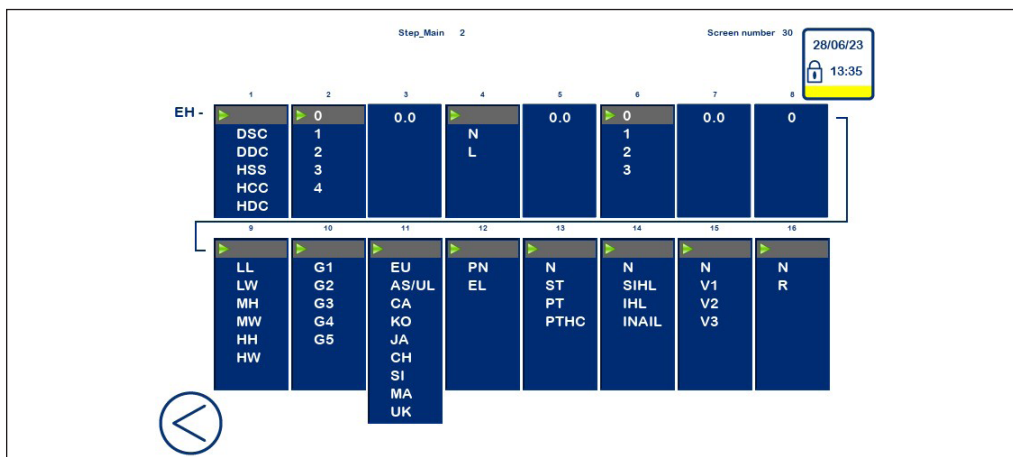

7. Select controls

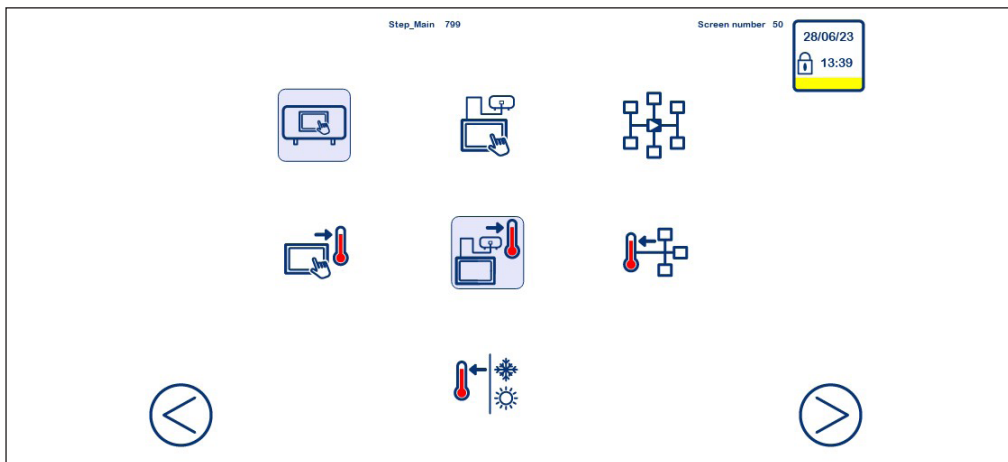

8. Select operating conditions

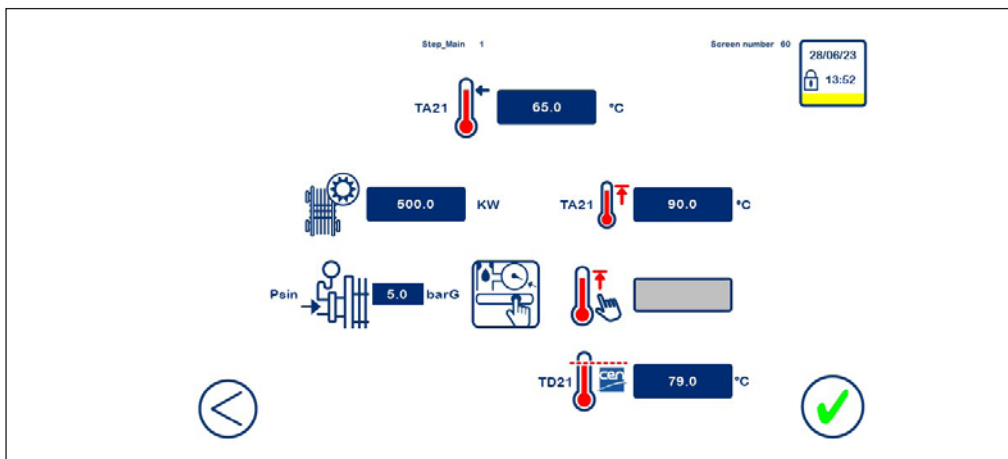

9. Complete commissioning by selecting green tick



4.5 Start-up procedure

- Ensure that supply is available to the system at the required pressure and that condensate is free to flow from the system.
- Ensure water flows

1. Navigate to home screen



2. Push start button



If start button is not visible check for alarms and diagnostic messages, or manual controls (see operating instructions IM-P565-10 for more details)

3. Monitor status messages

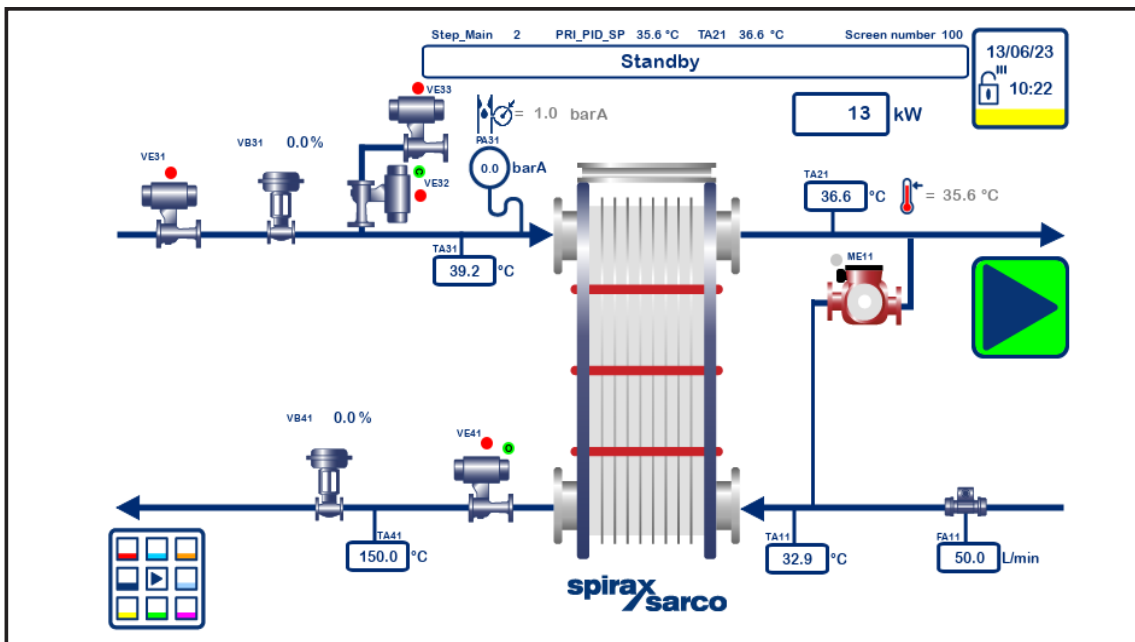

4. When the status message reads 'running' the start-up is complete

4.6 Shutdown

1. Navigate to home screen



2. Push stop button



3. Monitor status messages
4. When the status message reads 'standby' the shutdown is complete

5. Fault finding

| Fault | Possible cause | Remedial action |
|--|--|--|
| Inability to accurately control temperature and or repeated tripping of high limit | Pump is blocked, worn or experiencing loss of power | Maintain pump or replace completely |
| | PID Tuning being incorrect for installation | Retune the EasiHeat system |
| | Unstable flow on the water/secondary side | Investigate hot water system to ensure flowrate is within specified operating conditions for the installation |
| | Scaling of the temperature sensor | Descale temperature sensor |
| | Failure/Wear of steam side control components | Check the correct operation of control valve(s)/ trap(s)/pump trap |
| | Wiring fault(s) relating to control equipment | Check function and integrity of control equipment |
| Inability to reach set-point temperature/rated kW output EasiHeat system | Steam side strainer has become blocked | Maintain strainer as per products IMI |
| | Heat Exchanger, heat from steam to water not transferred effectively | Treat steam and water supply, maintain heat exchanger |
| | Valve position calibration drifted/incorrect | Recalibrate/Re-stroke the actuator |
| | Failure/Wear of steam side control components | Check the correct operation of control valve(s)/ trap(s)/pump trap |
| Control valves not shutting off tightly | Corrosion, wear and tear | If pneumatic, filter media may be damaged and or saturated filter Service valve internals |
| | Valve position calibration drifted/incorrect. | Recalibrate/Re-stroke the actuator |
| Valve position not being representative of the displayed value on the HMI/Positioner. | Lack of air supply | Check incoming supply |
| | Loss of electrical supply | Check incoming electrical supply to valve. |
| | Valve being incorrectly calibrated by Autostroke feature/not calibrated. | Re-run the Autostroke/Calibration operation on the valve. |
| | Valve feedback connected to wrong M12 connector. | Check valve feedback cables match M12 connectors on panel. |
| Steam/Pump trap leaking steam /Excessive live steam in condensate return | Worn internal components/failed open | Maintain or replace product as per associated IMI's |
| Manual isolation valve has become stuck open or shut – Package can not be isolated | Wear | Maintain valve as per products IMI or replace completely |
| Pressure transmitter (PA31) input is not showing correctly | Scaling value incorrect | Ensure that the minimum and maximum engineering units from the pressure transmitter (PA31) match those on the HMI. |
| | Polarity of 4-20 mA incorrect | Rewire as per electrical drawings. |
| | Pressure transmitter (PA31) connected to the wrong M12 socket. | Check the pressure transmitter (PA31) cable label and socket match. |
| Bypass pump does not operate | Field wiring fault | Check wiring of pump to terminals ME11. |
| | Internal circuit breaker tripped. | Check circuit breaker Q2. |

Continued on next page

| Fault | Possible cause | Remidial action |
|--|--|--|
| Temperature measurement signal not reading correctly (TA11, TA21, TA31, TA41, TA51) | PT100 connected to wrong M12 socket. | Check the M12 cable label and socket match. |
| | Faulty sensor | Check compensated resistance |
| Flowmeter (FA11) does not power up | Flowmeter (FA11) connected to the wrong M12 socket. | Check the flowmeter (FA11) cable label and socket match. |
| | Loss of loop power | Check smart fuse channel 3 (24D11) |
| Flowmeter (FA11) input is not showing correctly | Scaling value incorrect | Ensure that the minimum and maximum engineering units from the Flowmeter (FA11) commisioning match those on the HMI (this data is found in section 4.3) |
| | Polarity of 4-20 mA incorrect | Rewire as per electrical drawings. |
| | Flowmeter (FA11) connected to the wrong M12 socket. | Check the flowmeter (FA11) cable label and socket match. |
| Flowmeter providing incorrect values for flow (FA11) | Orientation of flow meter (FA11) incorrect. | Refer to IMI section 4.3.4 |
| Remote set point is not showing correctly | Scaling value incorrect | Ensure that the minimum and maximum engineering units from the remote set point match those on the HMI (this data is found on the Spirax Sarco engineers 4-20 mA page) |
| | Polarity of 4-20 mA incorrect | Rewire as per electrical drawings. |
| Loss of 24 Vdc supply | Internal circuit breaker trip | Check breaker Q3. |
| | Internal cartridge fuse blown | Check fuse F3 (and F4 and F5 where fitted). |
| | Smart fuse trip | Check smart fuse and reset trip channels refer to IMI section 6.7. |
| Loss of 24 Vac supply | Internal cartridge fuse blown | Check fuse F6. |
| | Internal circuit breaker trip | Check breaker Q1. |
| UPS option only – Upon power loss steam valve remains open | Electrical failure of the UPS or other electrical components connected to it | Maintain or replace electrically failed components (note: person must be suitably qualified) refer to Section 6.5 |

6. Maintenance



Note: Before actioning any maintenance observe the 'Safety information' in Section 1.

6.1 General

For maintenance of the individual components that make up the system, please see the relevant product specific IMI's for the components concerned.

To open the panel of the EasiHeat system you require the standard panel key supplied with the unit.

For a system specific service and maintenance plan that encompasses routine preventative maintenance actions please contact your local Spirax Sarco sales office.

6.2 High limit device testing

The purpose of the test is to ensure that the system operates satisfactorily when required to do so.

Method:

1. High limit set point test - The set point of the high limit controller should be lowered, to simulate a high temperature situation. Test personnel should ensure the high limit device operates in a satisfactory manner.

2. Electrical power failure test - The unit should be turned off at the PLC controller switch to simulate power failure. Examination should be made to ensure the high limit system has switched to its fail-safe mode, isolating the primary steam supply.

3. Frequency

It is essential that a competent person tests the high limit device on a frequent basis. Intervals between tests should not exceed a six month period.

We do not recommend the installation of a self-acting high limit control to the EasiHeat system.

6.3 Scale formation

Within open systems, where there is continual make-up water, there is a risk of scale formation. The extent of the scale will depend largely upon the water quality, which varies greatly from area to area. A test, conducted by a water treatment specialist, is recommended to determine the local water quality and whether problems are foreseen.

After extended service, the plate heat exchanger can be easily dismantled for cleaning. If scale becomes a persistent problem, regular chemical cleaning should be considered.

'Clean in Place' apparatus. It should be noted that raising the steam pressure could result in an increase of scaling.

6.4 Local isolator

When the control panel is switched off from mains power a padlock or similar device can be used to lock the isolator switch by lifting the center section of red isolator to expose a locking hole.

6.5 Batteries/Maintenance

If the option for a Uninterruptable Power Supply (UPS) is selected It is recommended that batteries are replaced according to the lifetime chart below.

Use panel temperature TAX1 to guide replacement period.

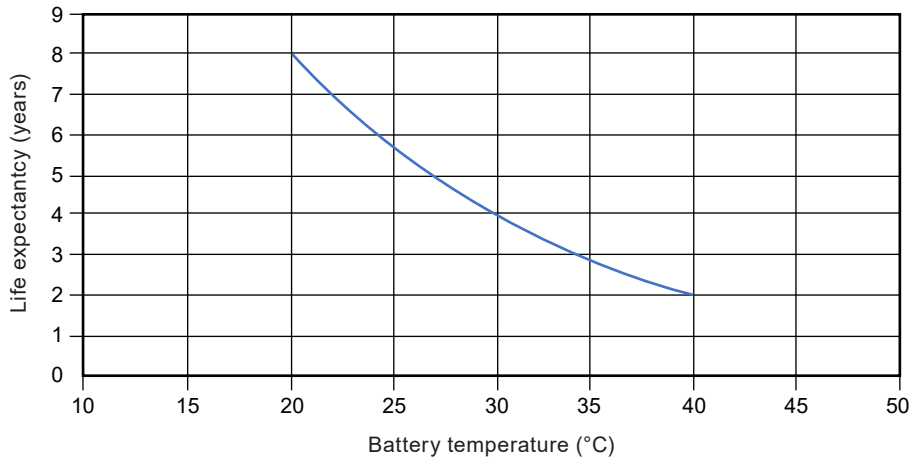

Fig. 8 UPS battery life

6.5.1 Replacement of Battery/UPS

Only a suitably qualified person should replace the batteries of the UPS when this is required.

To replace the batteries of the UPS, ensure the EasiHeat unit is turned off and the UPS is not supplying power to the panel.

Remove the battery fuse, and undo the two battery housing cover retaining screws with a Torx 20 screwdriver.

Disconnect the internal wiring to the batteries, paying attention to which wires and terminals are connected.

Remove the batteries and dispose as per national regulations.

Insert the new batteries, and reconnect the internal wiring, paying attention to the polarity and matching the previous connections.

Replace the housing cover, and secure with the screws and Torx 20 screwdriver.

Plug the battery fuse back in.

Turn the panel back on, and allow the UPS to fully charge the battery.

6.6 Functional test of safety components

To test the functionality of the safety components on the EasiHeat system please do the following;

1 .E-stop test – Press estop and ensure system stops in a safe manner

- 1a. Customer E-stop (If fitted) - Press customer E-stop and ensure system stops in a safe manner.

2. High limit test – For SxS high limit and EN14597 high limit, undo the 2 screws and remove the cover, adjust the dial on the temperature sensor until setpoint is below current water temp and ensure high limit valve closes. For INAIL high limit, disconnect connection to the sensor and ensure high limit valve closes (Note, this does not test the high limit temp sensor itself – to do this, the sensor must be heated to a temperature over the trip temperature).

3. Air Pressure fault test (if option fitted) – cut pneumatic air supply to the unit and verify system stops in a safe manner

4. UPS run fault test (if option fitted) – Cut power to the unit and ensure system stops in a safe manner

5. UPS fault test (if option fitted) – Pull the integrated UPS battery fuse (located on the right side of the UPS battery unit in the control panel) and ensure the system stops in a safe manner.

Note:

At the end of each functional safety test fault condition should be removed on the HMI and the system should not automatically restart.

6.7 Smart fuse

The EasiHeat is equipped with an electronic circuit protection module, sometimes called a “smart fuse”. This allows programmatic resets of voltage supplies in the event of a tripped fuse. The EasiHeat control software will attempt to reset channels in the event of a trip. Should a channel trip that the control software cannot reset, a suitably qualified person should carefully ascertain the cause of the trip and resolve it, before resetting the protection manually. This can be done by pressing the associated channel button with integrated LED located on the unit. The LED indicates the state of each channel – please see below for codes:

| Display | State | Indication |
|--------------------------|--------------|-------------------------------------|
| Green | Connected | Function ok |
| Red | Disconnected | Manually disconnected |
| Green flashing | Threshold | Load above 90% of operating current |
| Red flashing 1Hz | Disconnected | Load above 90% of operating current |
| Red flashing quickly 5Hz | Defect | Internal fault |

7. Component map

7.1 Component naming convention

The naming convention for the system map do not correlate to the specific parts and part numbers. The tag names are specific to the EasiHeat system and are not tied to specific component models. To identify a particular component, reference the component tag number to the Bill Of Materials for the specific model of Easiheat.

The tag numbers can be deciphered to aid identification and location of the component on the Easiheat.

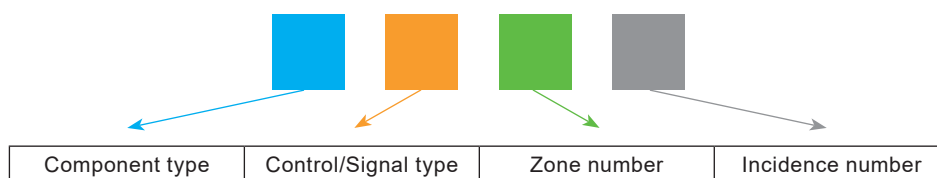

7.1.1 Component types

Opposite is a table of currently identified component types.

| Letter | Component type |
|--------|--|
| F | Flow sensor |
| H | Heat exchanger (preheater, sample cooler, etc) |
| P | Pressure sensor |
| T | Temperature sensor |
| V | Valve (globe, ball, check, Vacuum breaker, butterfly, etc) |

7.1.2 Control/signal type

Opposite is a table of currently identified Control and Signal types. The direction of signals is always reference in relation to the PLC or process controller.

| Letter | Control/Signal type |
|--------|---------------------------|
| A | Analogue input (signal) |
| B | Analogue output (control) |
| D | Digital input |
| E | Digital output |
| M | Manual control |

7.1.3 Area allocation

Areas are used to segregate areas of the package into sub-areas based around state changes of the process of the package.

Numbering of the Areas begins with the inlet flow of the process fluid at Area 0. When the process fluid undergoes a change or state change, the Area number increases until it leaves the Easiheat.

The inlet of the control fluid begins with the next available Area number. At each state change of the control fluid, increase the Area number until the control fluid leaves the package.

Components located externally to the steam system are always labelled as Area X.

7.1.4 Incidence number

Where multiples of similar devices and parts occur in the same Area, incidence numbers are used to distinguish between them.

Starting points for incidence numbers always start from the component closest the entry of the Area area.

e.g. On a condensate line, 2 manual valves are identified in Area 5. The first of the manual valves to come into contact with the condensate as it passes through Area 5 will be given the Incidence number 1.

7.2 Component definitions

- Area 1 for return water connection to main heat exchanger connection.
- Area 2 for heated water from main heat exchanger to water outlet.
- Area 3 for plant steam from steam inlet to connection to main heat exchanger.
- Area 4 for condensate from connection to main heat exchanger to trap.
- Area 5 for drain condensate from trap connection to condensate return connection.

7.2.1 Area 1 Return water

- TA11 Return water temperature analogue input signal.
- FA11 Bypass water flow rate analogue input signal.
- HU11 Main heat exchanger.
- ME11 Recirculation pump.

7.2.2 Area 2 Heated water

- TA21 Outlet water temperature analogue input.
- TD21 Outlet water temperature high limit switch.

7.2.3 Area 3 Plant steam

- PA31 Plant steam supply pressure analogue input.
- VE31 Plant steam digital isolation valve (open signal output).
 - VD31 Plant steam isolation valve fully open digital input.
 - VD32 Plant steam isolation valve fully closed digital input.
- VE32 Test, air isolation valve (open signal output).
 - VD33 air isolation valve fully open digital input.
 - VD34 air isolation valve fully closed digital input.
- VE33 Test, air vent valve (pressurise signal output).
- VB31 Plant steam control valve analogue output (low flow).
 - VA31 Plant steam control valve feedback analogue input.
 - VD35 Plant steam control valve fully closed digital input.
- VB32 Auxiliary steam control valve analogue output (high flow).
 - VA32 Auxiliary steam control valve feedback analogue input.
 - VD36 Auxiliary steam control valve fully closed digital input.

7.2.4 Area 4 Condensate

- TA41 Pre-trap condensate temperature analogue input.
- VE41 Test, condensate isolation valve (closed signal output).
 - VD41 condensate isolation valve fully open digital input.
 - VD41 condensate isolation valve fully closed digital input.
- VB41 Condensate control valve analogue output.
 - VA41 Condensate valve feedback analogue input.

7.2.5 Area 5 Condensate exhaust

- TA51 Post-trap condensate temperature analogue input.

7.2.6 Area X External to steam system

- PDX1 Air pressure switch.
- VEX1 Combined air pressure dump valve.
- VEX2 Steam control valve air pressure dump valve.
- VEX3 Auxiliary/condensate control valve air pressure dump valve

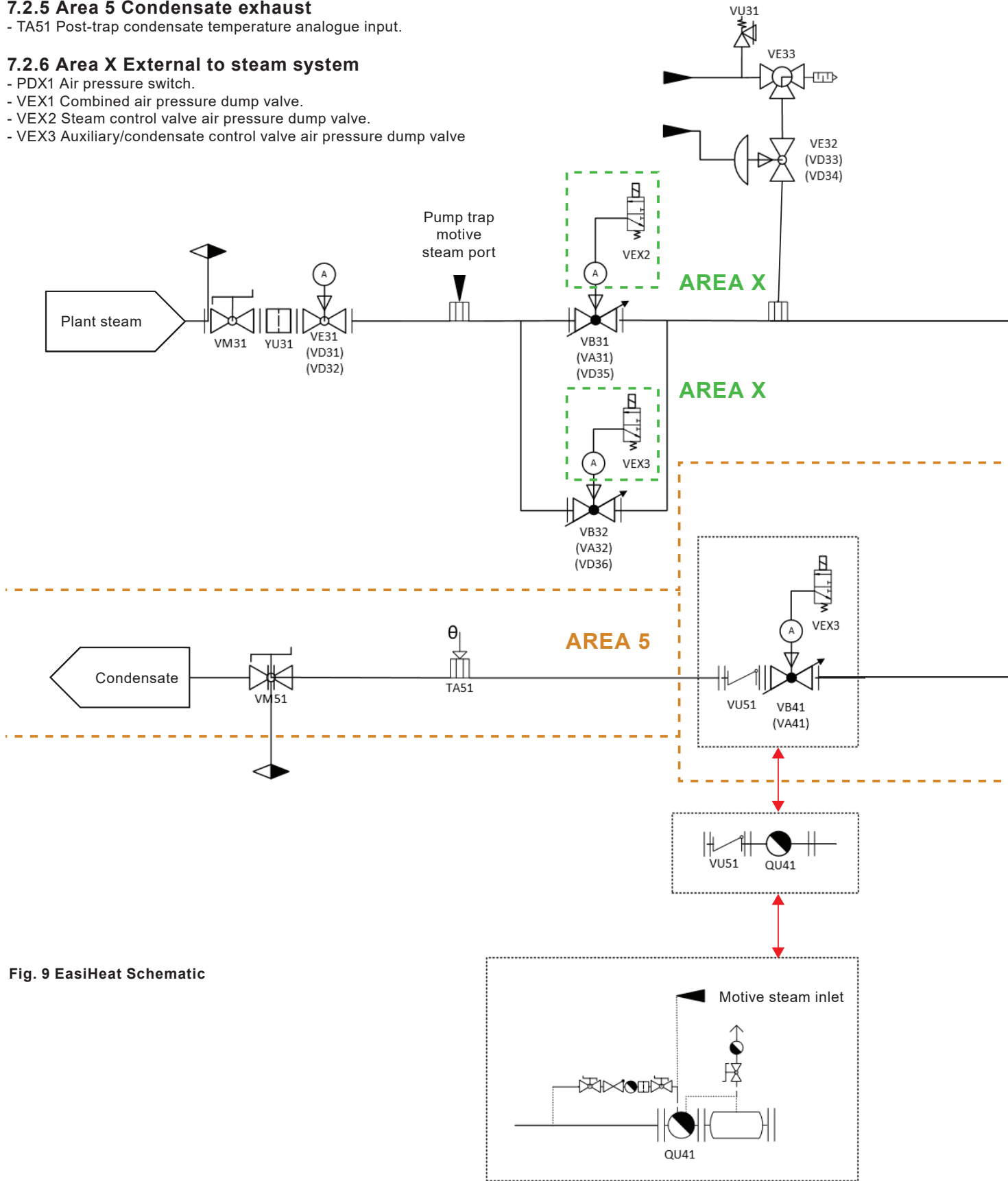
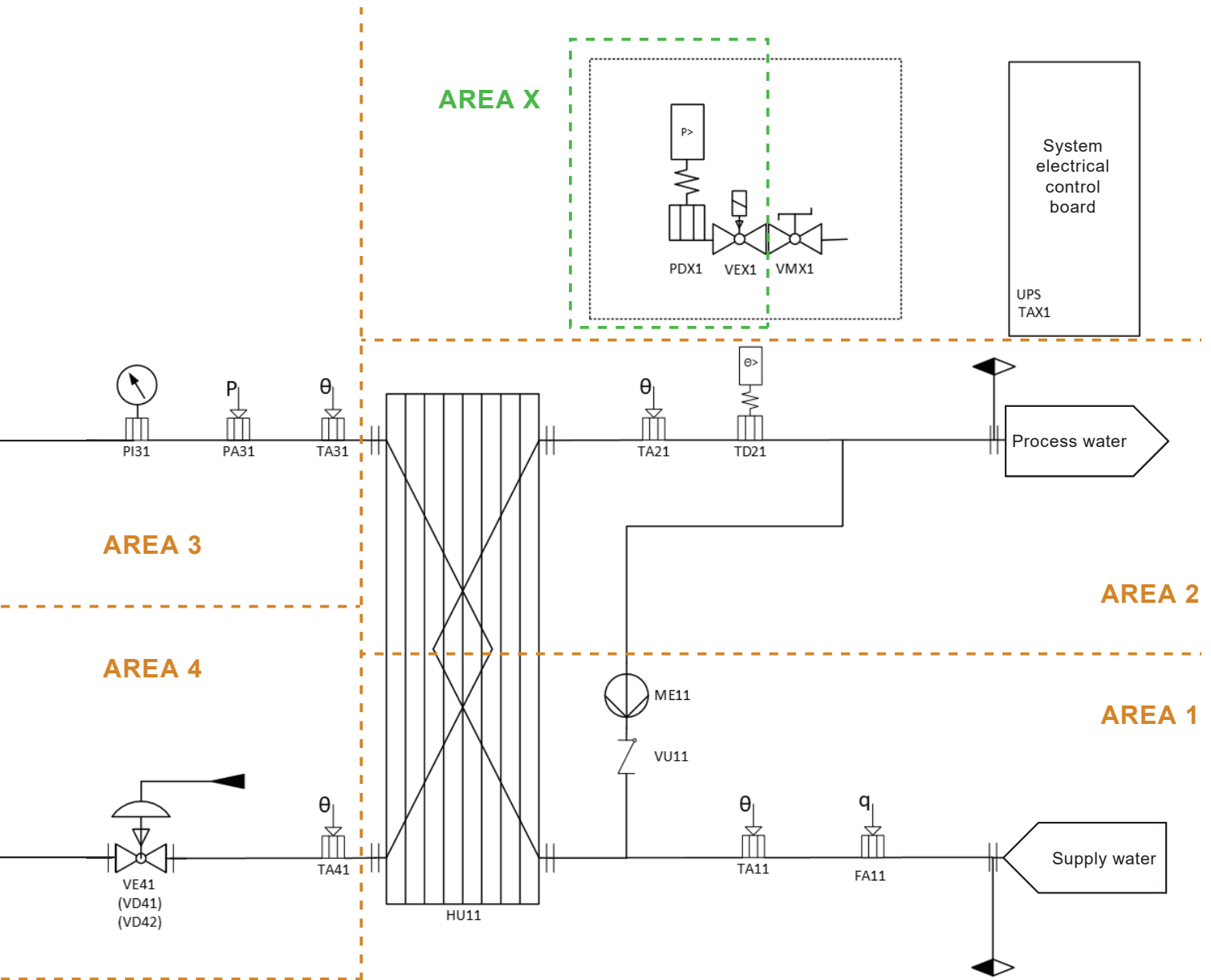

Fig. 9 EasiHeat Schematic



Service

For technical assistance contact our nearest Office or Agency.

Warranty

Ascertained partial or complete non-compliance with these regulations will result in forfeiture of the related warranty.

EasiHeat

spirax
sarco

