

---

**Dri-Line Mk3**  
**Monnier Compressed Air Drain Trap**  
Installation and Maintenance Instructions

---



1. Safety information
2. General product information
3. Installation and Operation
4. Spare parts and Maintenance



# 1. Safety information

Safe operation of this product can only be guaranteed if it is properly installed, commissioned, used and maintained by qualified personnel (see Section 1.11) in compliance with the operating instructions. General installation and safety instructions for pipeline and plant construction, as well as the proper use of tools and safety equipment must also be complied with.

## 1.1 Intended use

Referring to the Installation and Maintenance Instructions, name-plate and Technical Information Sheet, check that the product is suitable for the intended use/application. The product complies with the requirements of the European Pressure Equipment Directive 2014/68/EU and falls within the category 'SEP'.

It should be noted that products within this category are required by the Directive not to carry the  mark.

- i) This product has been specifically designed for use on compressed air, which is in Group 2 of the above mentioned Pressure Equipment Directive. The products' use on other fluids may be possible but, if this is contemplated, Spirax Sarco should be contacted to confirm the suitability of the product for the application being considered.
- ii) Check material suitability, pressure and temperature and their maximum and minimum values. If the maximum operating limits of the product are lower than those of the system in which it is being fitted, or if malfunction of the product could result in a dangerous overpressure or overtemperature occurrence, ensure a safety device is included in the system to prevent such over-limit situations.
- iii) Determine the correct installation situation and direction of fluid flow.
- iv) Spirax Sarco products are not intended to withstand external stresses that may be induced by any system to which they are fitted. It is the responsibility of the installer to consider these stresses and take adequate precautions to minimise them.
- v) Remove protection covers from all connections and protective film from all name-plates, where appropriate, before installation on steam or other high temperature applications.

## 1.2 Access

Ensure safe access and if necessary a safe working platform (suitably guarded) before attempting to work on the product. Arrange suitable lifting gear if required.

## 1.3 Lighting

Ensure adequate lighting, particularly where detailed or intricate work is required.

## 1.4 Hazardous liquids or gases in the pipeline

Consider what is in the pipeline or what may have been in the pipeline at some previous time. Consider: flammable materials, substances hazardous to health, extremes of temperature.

## 1.5 Hazardous environment around the product

Consider: explosion risk areas, lack of oxygen (e.g. tanks, pits), dangerous gases, extremes of temperature, hot surfaces, fire hazard (e.g. during welding), excessive noise, moving machinery.

## 1.6 The system

Consider the effect on the complete system of the work proposed. Will any proposed action (e.g. closing isolation valves, electrical isolation) put any other part of the system or any personnel at risk?

Dangers might include isolation of vents or protective devices or the rendering ineffective of controls or alarms. Ensure isolation valves are turned on and off in a gradual way to avoid system shocks.

## 1.7 Pressure systems

Ensure that any pressure is isolated and safely vented to atmospheric pressure. Consider double isolation (double block and bleed) and the locking or labelling of closed valves. Do not assume that the system has depressurised even when the pressure gauge indicates zero.

## 1.8 Temperature

Allow time for temperature to normalise after isolation to avoid danger of burns.

## 1.9 Tools and consumables

Before starting work ensure that you have suitable tools and/or consumables available. Use only genuine Spirax Sarco replacement parts.

## 1.10 Protective clothing

Consider whether you and/or others in the vicinity require any protective clothing to protect against the hazards of, for example, chemicals, high/low temperature, radiation, noise, falling objects, and dangers to eyes and face.

## 1.11 Permits to work

All work must be carried out or be supervised by a suitably competent person.

Installation and operating personnel should be trained in the correct use of the product according to the Installation and Maintenance Instructions.

Where a formal 'permit to work' system is in force it must be complied with. Where there is no such system, it is recommended that a responsible person should know what work is going on and, where necessary, arrange to have an assistant whose primary responsibility is safety.

Post 'warning notices' if necessary.

## 1.12 Handling

Manual handling of large and/or heavy products may present a risk of injury. Lifting, pushing, pulling, carrying or supporting a load by bodily force can cause injury particularly to the back. You are advised to assess the risks taking into account the task, the individual, the load and the working environment and use the appropriate handling method depending on the circumstances of the work being done.

### **1.13 Residual hazards**

In normal use the external surface of the product may be very hot. If used at the maximum permitted operating conditions the surface temperature of some products may reach temperatures of 90 °C (194 °F).

Many products are not self-draining. Take due care when dismantling or removing the product from an installation (refer to 'Maintenance instructions').

### **1.14 Freezing**

Provision must be made to protect products which are not self-draining against frost damage in environments where they may be exposed to temperatures below freezing point.

### **1.15 Disposal**

Unless otherwise stated in the Installation and Maintenance Instructions, this product is recyclable and no ecological hazard is anticipated with its disposal providing due care is taken.

Please visit the Spirax Sarco product compliance web pages

<https://www.spiraxsarco.com/product-compliance>

for up to date information on any substances of concern that may be contained within this product. Where no additional information is provided on the Spirax Sarco product compliance web page, this product may be safely recycled and/or disposed providing due care is taken. Always check your local recycling and disposal regulations.

### **1.16 Returning products**

Customers and stockists are reminded that under EC Health, Safety and Environment Law, when returning products to Spirax Sarco they must provide information on any hazards and the precautions to be taken due to contamination residues or mechanical damage which may present a health, safety or environmental risk. This information must be provided in writing including Health and Safety data sheets relating to any substances identified as hazardous or potentially hazardous.

## 2. General product information

### 2.1 General description

The Monnier Dri-Line Mk3 is an automatic float actuated drain used to drain air line drain legs and filters. It is a normally open valve that is rated for use up to 17 bar g and 80 °C (246.5 psi and 176 °F). The valve is held closed by line pressure.

The pilot valve is never submerged in water, and its discharge is operated by system air pressure, producing a strong on-off action. The float which is extremely light, can't leak or hold fluid. All parts are corrosion proof. The unit has a manual override to check proper functioning. Discharge is easily piped to remote locations. When the compressed air system is shut down, the valve returns to its normally open condition and water will drain away by gravity.

- Principal features:**
- Blast action discharge.
  - High discharge capacity.
  - Built-in strainer screen.
  - Discharge can be piped to drain.
  - Black anodised finish - internal and external.

### 2.2 Sizes and pipe connections

½" screwed BSP T Rp (ISO 7-1) .

### 2.3 Operating limits

Maximum working pressure	17 bar g	(246.5 psi g)
Minimum operating pressure	0.1 bar g	(1.5 psi g)
Maximum working temperature	80 °C	(176 °F)
Maximum discharge capacity	20 L/h @ 6 bar	(4.4 UK gallons/h @ 87 psi)

### 2.4 Materials

Part	Material	
Body	Anodised coated aluminium	LM25WP
Autodrain mechanism	Acetal plastic/Stainless steel	
Strainer screen	0.8 mm perforated	316L
'O' ring	Nitrile	



Fig. 1 Dri-line Mk3

# 3. Installation and Operation

**Note:** Before actioning any installation observe the 'Safety information' in Section 1.

Referring to the Installation and Maintenance Instructions, name-plate and Technical Information Sheet, check that the product is suitable for the intended application.

## 3.1 Installation:

- The Dri-Line Mk3 should be fitted with the inlet port (top or side entry) at the top, so that the float mechanism can rise and fall vertically.
- Adequate space should be provided around the unit to allow easy access for routine maintenance requirements (see Figure 2 for the dimensions of the unit to judge the required withdrawal distance required).
- The unit should be installed as close as possible to the equipment it is serving.

## 3.2 Operation

The Spirax-Monnier Dri-Line Mk3 is a self-acting device.



### 3.3 Typical installations

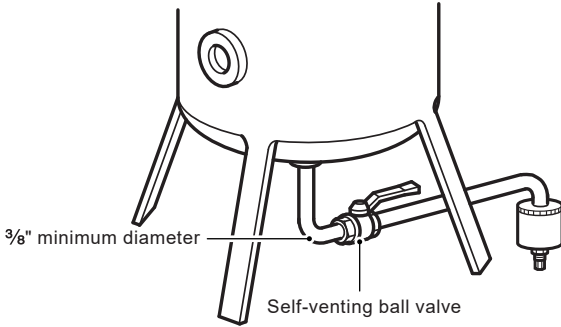

Fig. 2 Dri-Line Mk3 draining a receiver or larger filter

Fig. 3 Dri-Line Mk3 draining a compressed air main relay point

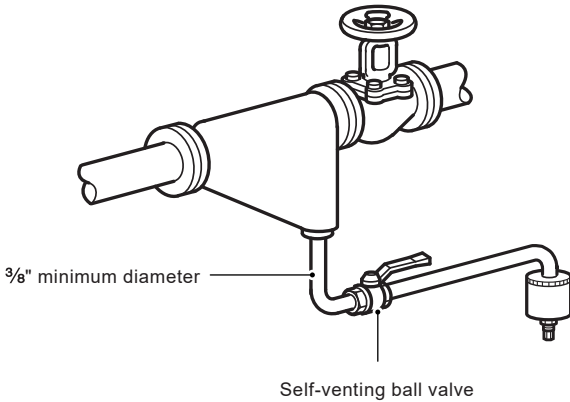
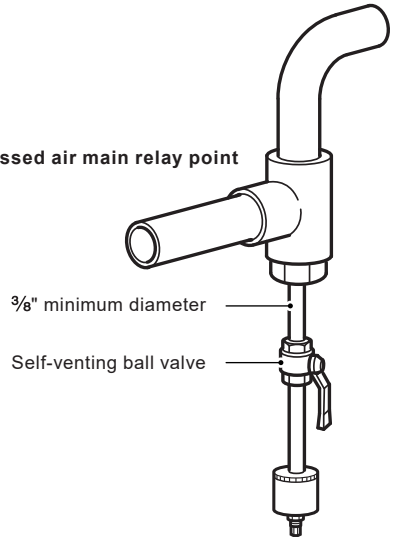

Fig. 4 Dri-Line Mk3 draining a separator on a compressed air main

# 4. Spare parts and Maintenance

## 4.1 Spare parts

The spare parts available are detailed below. No other parts are supplied as spares.

### Available spares

---

Internal autodrain mechanism and strainer cap 'O' ring	<b>A, B</b>
--	-------------

---

### How to order spares

Always order spares by using the description given in the column headed 'Available spares', and state the type of trap.

**Example:** 1 - Internal autodrain mechanism and strainer cap 'O' ring for a Dri-Line Mk3 Monnier compressed air drain trap.

## 4.2 Maintenance

**Note:** Before actioning any maintenance observe the 'Safety information' in Section 1.

- Isolate and vent the unit from the system pressure (preferably using a self-venting ball valve).
- The unit can be dismantled in-situ for either servicing / maintenance, or removed completely from the air system.

### 4.2.1 How to clean the strainer screen:

- Unscrew the strainer cap and remove the strainer screen from the body.
- Clean the strainer screen and refit. Fit a new 'O' ring. Tighten the strainer hand tight.

### 4.2.2 How to clean or replace the autodrain mechanism:

- Unscrew the top cap, and remove the strainer screen and autodrain mechanism.
- Unscrew the locking ring.
- Clean the screen using soap and water.

**Do not attempt to dismantle the autodrain mechanism (A) as it is a non-servicable item.**

- Refit or replace the autodrain mechanism and hand tighten using the locking ring.
- Insert the top cap complete into the body using a new 'O' ring and hand tighten.

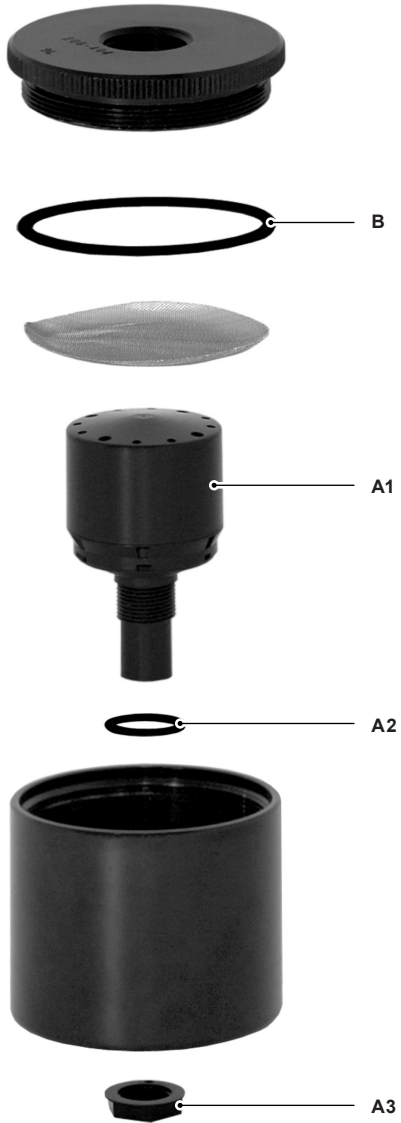

Fig. 5 Dri-Line Mk3 spares

