**DP143 and DP163
Pressure Reducing Valve Spares
Fitting Instructions**

Pilot Valve and Plunger Assembly**Pilot Valve Seal Assembly****Pilot Valve Chamber Assembly****Pilot Valve Diaphragms**

These fitting instructions apply to the afore mentioned spares and cover the complete range of DP143 and DP163 and derivatives including the 'G' suffix versions. The 'G' versions have soft seated valve trim for use on air and industrial gases.

Full Installation and Maintenance Instructions for the DP143 and DP163 range of pressure reducing valves are supplied with the product, reference IM-P006-07 (0060026).

Important note

Before actioning any maintenance program observe the 'Safety information' within IM-P006-07 (supplied with the product) available from Spirax Sarco.

Safety note

Care should be exercised when handling gaskets since the stainless steel reinforcing strip can easily inflict cuts.

Warning - DP163

The 316 type stainless steel used in the construction of the DP163 product, particularly for screwed or close fitting parts, is very susceptible to galling or cold welding. This is an inherent characteristic of this type of material and great care should be taken when dismantling or reassembling.

If the application permits, it is recommended that a light smear of a PTFE based grease is applied to any mating parts before reassembly.

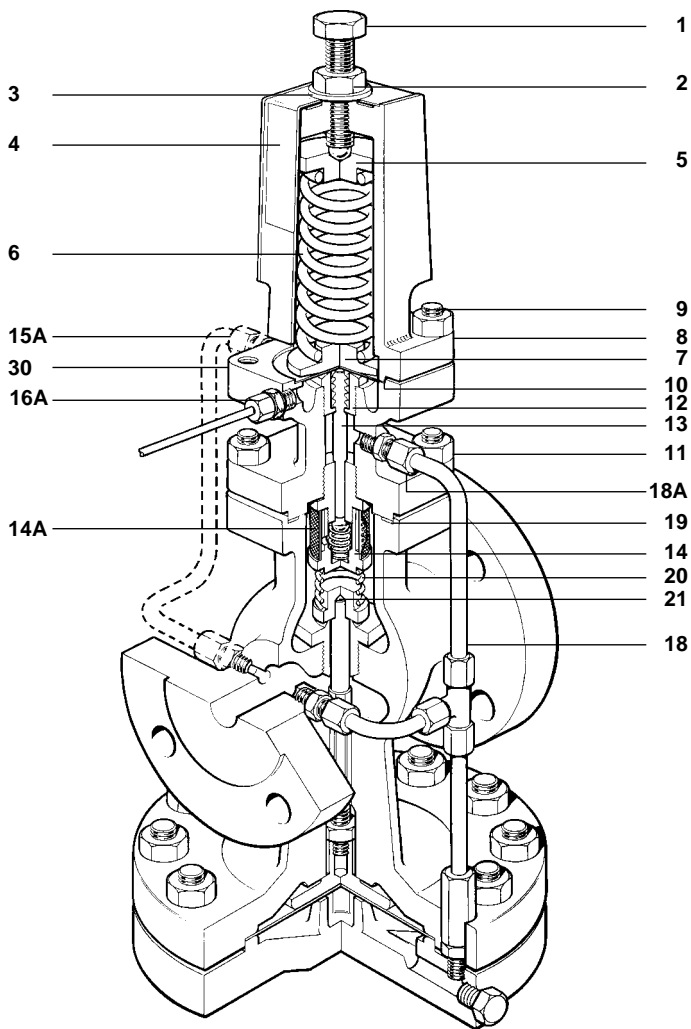

Fig. 1

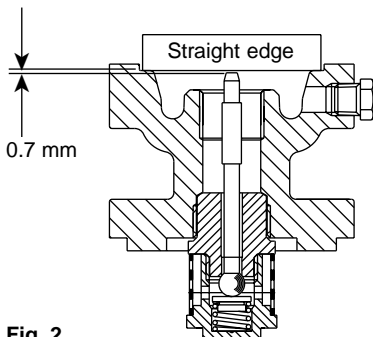

Fig. 2

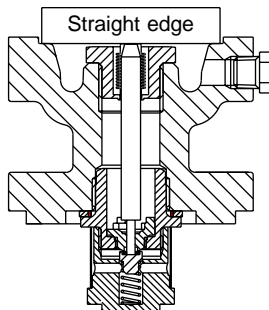

Fig. 3

1. Isolate the reducing valve and zero the pressure.
2. Release lock-nut (2) and turn adjustment screw (1) anticlockwise until spring is slack.
3. Slide out 'C' washer (3) from underneath lock-nut and remove cover (4).
4. Remove spring (6) and top spring plate (5).
5. Undo the 4 x M10 nuts (9) and remove spring housing (8), bottom spring plate (7) and diaphragms (10). **For diaphragm replacement only go to Step 17.**
6. Undo the union nut (18A) and the union nut (16A) or (15A) and release the 6 mm stainless steel pipework.
7. Undo the nuts (11) and remove the pilot valve chamber (30) making sure that the main valve spring (20) is still positioned correctly on top of the main valve head (21). **For pilot valve chamber replacement only, go to Step 14.**
8. Unscrew pilot valve seat assembly (14) which includes the integral strainer screen (14A) by using a 27 mm A/F socket and also remove plunger (13).
9. Unscrew bellows seal assembly (12) using a 24 mm A/F socket. If necessary this bellows seal assembly can be replaced.
10. With the bellows seal still removed screw in new pilot valve assembly (14) and tighten down to a torque of 115 N m. For the 'G' version a bonded seal is used between the pilot valve assembly and the block.
11. Insert plunger (13) in from the top and check that there is a gap of 0.7 mm between the top of the plunger and a straight edge placed across the diaphragm location recess (see Figure 2. Standard pilot valve illustrated).
Note: Because of production tolerances the plunger is supplied slightly longer than is always required and it will generally be necessary to grind or machine material off the top end to give the correct length. After machining make sure the sharp edges are removed from the top of the plunger as these could damage the bellows. The 0.7 mm gap (see Figure 2) ensures that with the bellows seal fitted there is just a slight gap between it and the diaphragm in its neutral position).
12. After locating the bellows seal assembly (12) carefully over the plunger (13) tighten down to a torque of 115 N m.
13. Check with straight edge again, that with the top of the bellows pressed lightly onto the top of the plunger, there is a slight clearance - a mere line of light between the straight edge and the top of the bellows (see Figure 3. 'G' pilot valve illustrated).
14. Before reassembling valve make sure that the gasket faces on both the pilot valve block and the body are clean and that the main valve spring (20) is positioned correctly on top of the main valve head (21).
15. Fit new gasket (19) and secure the pilot valve chamber assembly onto the body with the nuts (11). Tighten these nuts to the torques shown in Table 1.
16. Refit the 6 mm stainless steel pipework and retighten union nut (18A) and union nut (16A) or (15A) to ensure a steam tight seal.
17. Refit the two diaphragms (10) making sure that they are fitted the same way round as they were removed and that all contact surfaces are clean.
 If necessary two new diaphragms can be fitted at this stage.
18. Place the bottom spring plate (7) in position and secure the spring housing with the 4 x M10 nuts (9) tightening to a torque of 50 N m.
19. Replace the spring (6) and top spring plate (5) turning the adjustment screw (1) until it just locates on the top spring plate. Replace cover (4) and 'C' washer (3).
20. Bring valve back into commission.

Table 1 Recommended tightening torques for pilot valve block securing nuts item (11)

Size of valve	Nut size	Tightening torque
DN15LC, DN15 and DN20	M10	50 N m
DN25 to DN50	M12	60 N m
Note: for DN40 and DN50 valves predating 1996:-	M16	110 N m
DN40 and DN50	M16	110 N m
DN80	M12	80 N m

