

DP

Pilot Operated Pressure Reducing Valves Fitting Instructions

Main Valve Assembly, Main Valve Return Spring, Pushrod, Lock-nut and Main Diaphragm Plate Set.

Warning

For full Installation and Maintenance Instructions, inclusive of safety information, see the relevant documents supplied with the product and listed below.

Valve type	IM reference no.
37D and 37DE	IM - P102-04
DP143	IM - P006-07
DP17, DP17E and DP17R	IM - P100-05
DP17T and DP17TE	IM - P101-04
DP27	IM - P470-03
DP27T	IM - P470-09

Note: Installation and Maintenance Instructions are available separately from Spirax Sarco.

Fitting instructions

For the DP17, DP17E and DP17G:

Isolate the reducing valve and zero the pressure.

1. Release the lock-nut.
2. Turn the adjustment screw anticlockwise.
3. Slide out the 'C' washer.
4. Remove the cover.
5. Remove the spring and top plate.

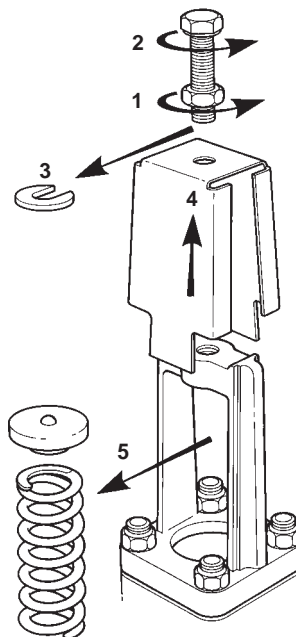

For the DP17R:

Isolate the actuating air supply.

For the 37D:

Allow the sensor bulb to cool before dismantling the valve.

6. Unscrew the unions and release the pipework.
7. Unscrew the nuts.
8. Remove the pilot valve housing.

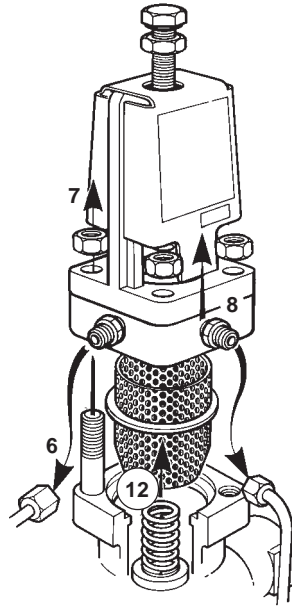

For the DP27, DP27E, DP27G and DP27Y:
Isolate the reducing valve and zero the pressure.

For the DP27R:

Isolate the actuating air supply and zero the pressure.

9. Unscrew the unions and release the pipework.
10. Unscrew the spring housing securing nuts.
11. **DP27, DP27E, DP27G and DP27Y:**
Remove the pilot valve housing, complete with the spring housing assembly.

DP27R:

Remove the pilot valve housing, complete with the air control block.

12. Remove the main valve screen and clean or replace as is necessary.

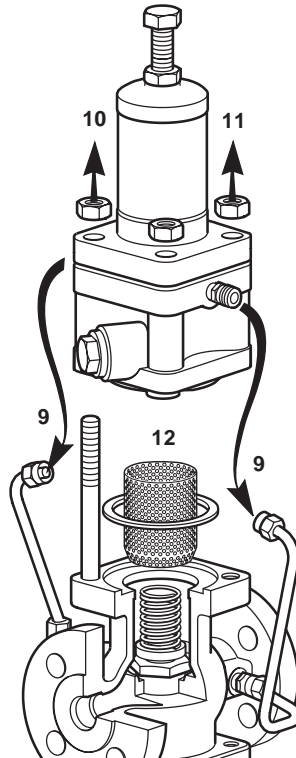

For the DP143, DP163 and SDP143:

Isolate the reducing valve and zero the pressure.

- 13. Undo the union nuts and release the 6 mm stainless steel pipework.
- 14. Undo the nuts and remove the pilot valve block complete with the spring housing assembly.

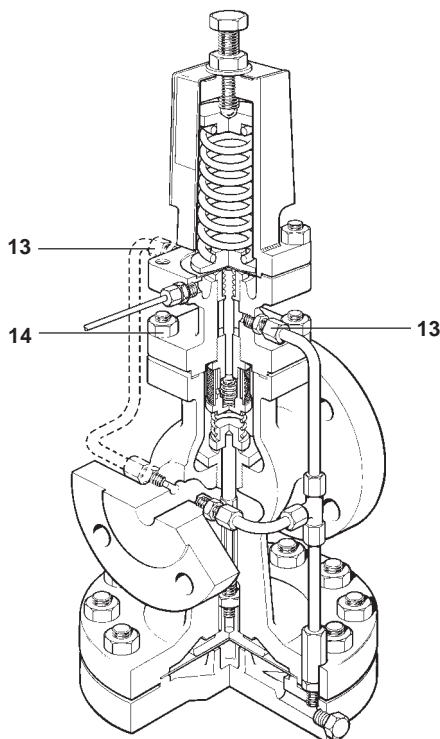

For all DP valves and variants:

- 15. Remove the main valve spring and the main valve head. Clean to remove dirt or scale as necessary.

- 16. Remove the main valve seat. Clean and remove dirt and scale as necessary.

Note: Examine the faces of the main valve head and seat. If they are only slightly worn they may be lapped on a flat plate using a fine grinding paste. If either is badly worn or unfit for further use they must be replaced.

DP_G variants

If there is wear or damage to the nitrile face then the head assembly must be replaced.

- 17. Refit the valve seat applying jointing compound to the seating faces and tighten to the recommended torque shown in Table 1.

Note: A special seat removal/replacement tool is available from Spirax Sarco.

Table 1 Recommended tightening torques for the main valve seat

Size of valve	Width across flats	Tightening torques	
		Nm	(lbf ft)
½" and ½" LC DN15 and DN15LC	30 mm A/F (External)	110 - 120	(81 - 89)
¾" and DN20	36 mm A/F (External)	140 - 150	(103 - 111)
1" and DN25	19 mm A/F (Inside)	230 - 250	(170 - 184)
DN32	24 mm A/F (Inside)	300 - 330	(221 - 243)
DN40	30 mm A/F (Inside)	450 - 490	(332 - 361)
DN50	41 mm A/F (Inside)	620 - 680	(456 - 502)
DN80	N/A	600 - 700	(443 - 516)

Where a new seat or head has been fitted or the main diaphragm plate and pushrod assembly is to be renewed it will be necessary to reset the main valve pushrod to give the correct valve lift. To do this it is necessary to expose the main diaphragm plate and pushrod assembly.

18. Undo the long nut and pull away.
19. Undo the M12 nuts and bolts.
20. Drop away the lower diaphragm chamber, the two diaphragms, diaphragm plate and pushrod assembly.

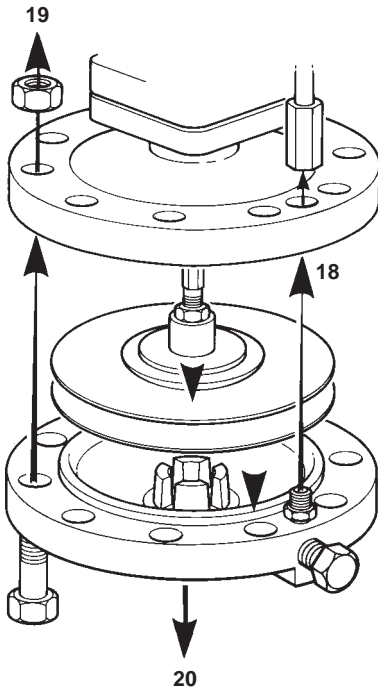

21. Refit or replace the diaphragm plate and pushrod assembly.
22. Refit the main valve head making sure that the valve head locates on the seat.
23. Check the valve lift shown in Table 2 using a depth gauge. Adjust if necessary by screwing the pushrod in or out of the diaphragm plate, when the desired length is established apply locking torque as listed in Table 3.

Table 2
Recommended valve lift settings

Size of valve	Valve lift
DN15	2.0 mm
DN20	2.5 mm
DN25	3.0 mm
DN32	3.5 mm
DN40	4.5 mm
DN50	5.0 mm
DN80	8.0 mm

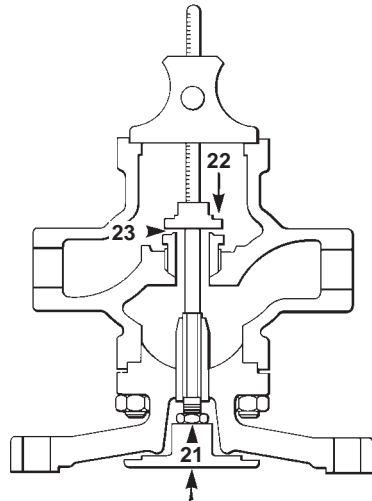
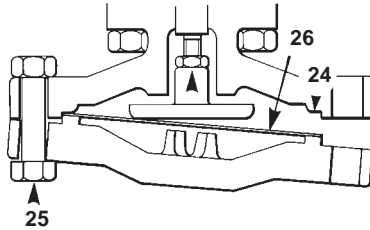

Table 3
Recommended tightening torques for pushrod lock-nut

Size of valve	N m	(lbf - ft)
DN15, DN20	15 - 20	(11 - 15)
DN25, DN32	25 - 30	(19 - 23)
DN40, DN50	45 - 50	(33 - 37)
DN80	60 - 70	(45 - 52)

24. Thoroughly clean the upper and the lower diaphragm chamber contact faces.
25. Replace the diaphragm plate and pushrod assembly and loosely fit the lower diaphragm chamber using the bolts either side of the union connection to locate the spigot in the recess.
26. Bring the two new diaphragms together (where precoated sealant is applied this should face outwards) and slide into position or refit in exactly the same way as when dismantled.



27. Push the lower diaphragm chamber home to locate in the recess and refit the M12 nuts and bolts. Progressively and evenly tighten to a torque of 80 - 100 N m (59 - 74 lbf ft).
28. Retighten the long union nut to ensure a steam tight seal.

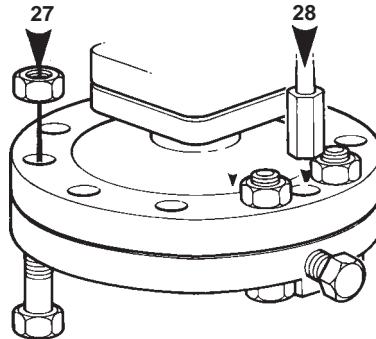

29. Refit the main valve head.
30. Replace or renew the main valve return spring.
31. Fit the new gasket.

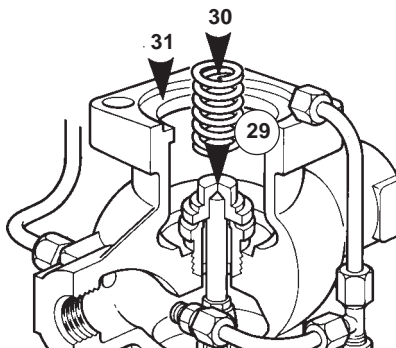

32. DP and all derivatives except R - Assemble the pilot valve housing complete with the spring housing assembly and tighten the nuts to the recommended torques shown in Table 4.

For the DP17R and DP27R - Assemble the pilot valve housing complete with air control block and tighten the nuts to the recommended torques shown in Table 4.

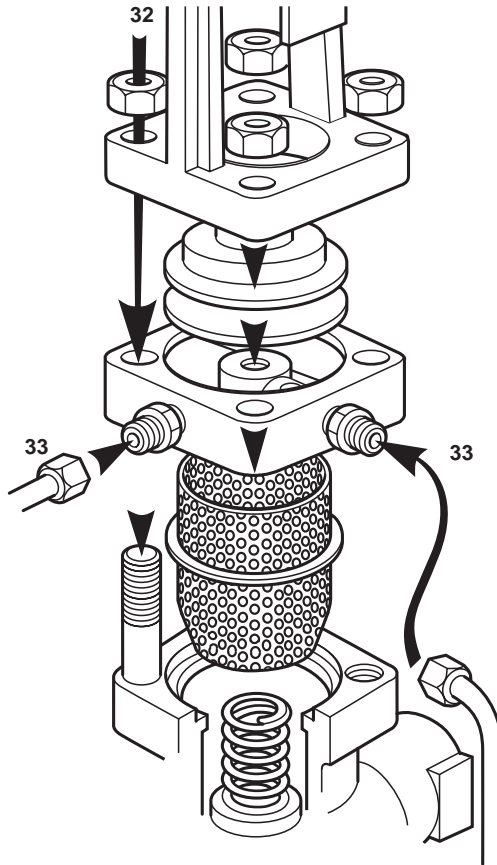

DP17 shown

33. Refit the pipework and retighten the unions to ensure a tight seal.
Bring the valve back into commission by following the instructions below.

Table 4 Recommended tightening torques for the pilot valve block securing nuts.

DP143, DP163, SDP143 and derivatives:

Size of valve	Nut size	Tightening torque Nm (lbf ft)	
DN15LC, DN15 and DN20	M10	40	(30)
DN25 to DN50	M12	60	(44)
Note: for DN40 and DN50 valves predating 1996:-	M16	110	(81)
DN80	M12	80	(59)

DP17, DP27 and derivatives:

Size of valve	Nut size	Tightening torque Nm (lbf ft)	
DP15, DN20, DN25 and DN32	M10	40	(30)
DP40 and DN50	M12	45	(33)

Commissioning

Start-up (Setting the valve)

1. Ensure that all connections are properly made and that all valves are closed.
2. Check that the adjustment is turned fully anticlockwise until the spring is slack.
3. Open the small valve in the pressure control line.
4. Blow through the approach pipework by removing the cap and screen from the strainer protecting the steam trap draining the upstream pipework. Replace upon completion. Do not remove the screen from the main line strainer during this operation. Although this should remove most of the dirt which is present, it may be necessary to examine and clean the main line strainer at regular intervals.
5. Slowly open the upstream isolating valve until it is fully open.
6. Using a 19 mm A/F spanner slowly turn the adjustment screw in a clockwise direction until the desired downstream pressure reading is obtained.
7. Holding the adjustment screw in position with the spanner tighten down the lock-nut to secure the setting of the adjustment spring, making sure that the 'C' washer stays in position (Figure. 1).
8. Slowly open the downstream valve until it is fully open.

