

DCV10 and DCV10C

Centrally Guided Disc Check Valves

Installation and Maintenance Instructions

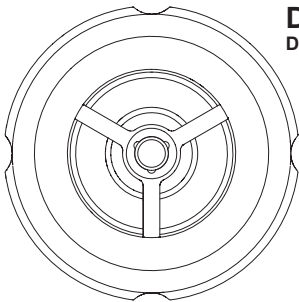

DCV10
DN25 - DN100

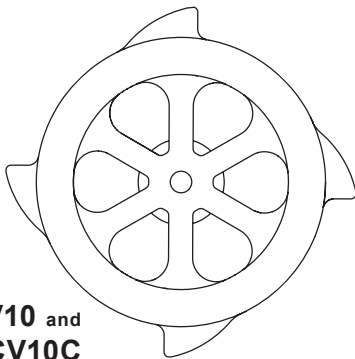

**DCV10 and
DCV10C**
DN125 - DN250

1. Safety information
2. General product information
3. Installation
4. Commissioning
5. Operation
6. Maintenance
7. Spare parts

1. Safety information

Safe operation of this product can only be guaranteed if it is properly installed, commissioned, used and maintained by qualified personnel (see Section 1.11) in compliance with the operating instructions. General installation and safety instructions for pipeline and plant construction, as well as the proper use of tools and safety equipment must also be complied with.

1.1 Intended use

Referring to the Installation and Maintenance Instructions, nameplate and Technical Information Sheet, check that the products are suitable for the intended use/application.

The products listed below comply with the requirements of the European Pressure Equipment Directive 2014/68/EU and carry the  marks when so required.

The products fall within the following Pressure Equipment Directive category:

Product		Group 2 Gases	Group 2 Liquids
DCV10	PN40 rated	DN25	SEP
		DN32	SEP
		DN40	1
		DN50	1
		DN65 - DN100	1
	ASME Class 300 rated	DN25	SEP
		DN40	1
		DN50	1
		DN65 - DN100	1
		DCV10 and DCV10C	DN125
DN150	2		
DN200	2		
DN250	2		

- i) These products have been specifically designed for use on steam, compressed air, water and other industrial fluids that are in Group 2 of the above-mentioned Pressure Equipment Directive and the Pressure Equipment (Safety) Regulation.
- ii) Check material suitability, pressure and temperature and their maximum and minimum values. If the maximum operating limits of the product are lower than those of the system in which it is being fitted, or if malfunction of the product could result in a dangerous overpressure or overtemperature occurrence, ensure a safety device is included in the system to prevent such over-limit situations.
- iii) Determine the correct installation situation and direction of fluid flow.
- iv) Spirax Sarco products are not intended to withstand external stresses that may be induced by any system to which they are fitted. It is the responsibility of the installer to consider these stresses and take adequate precautions to minimise them.
- vi) Prior to use, the user shall ensure the fluid compatibility with the equipment material.

1.2 Access

Ensure safe access and if necessary a safe working platform (suitably guarded) before attempting to work on the product. Arrange suitable lifting gear if required.

1.3 Lighting

Ensure adequate lighting, particularly where detailed or intricate work is required.

1.4 Hazardous liquids or gases in the pipeline

Consider what is in the pipeline or what may have been in the pipeline at some previous time. Consider: flammable materials, substances hazardous to health, extremes of temperature.

1.5 Hazardous environment around the product

Consider: explosion risk areas, lack of oxygen (e.g. tanks, pits), dangerous gases, extremes of temperature, hot surfaces, fire hazard (e.g. during welding), excessive noise, moving machinery.

1.6 The system

Consider the effect on the complete system of the work proposed. Will any proposed action (e.g. closing isolation valves, electrical isolation) put any other part of the system or any personnel at risk? Dangers might include isolation of vents or protective devices or the rendering ineffective of controls or alarms. Ensure isolation valves are turned on and off in a gradual way to avoid system shocks.

1.7 Pressure systems

Ensure that any pressure is isolated and safely vented to atmospheric pressure.

Consider double isolation (double block and bleed) and the locking or labelling of closed valves. Do not assume that the system has depressurised even when the pressure gauge indicates zero.

1.8 Temperature

Allow time for temperature to normalise after isolation to avoid the danger of burns. Valves fitted with the Fluoroelastomer (Fluorocarbon polymer FEPM (TFEP)) 'O' ring must not be subjected to temperatures above 315 °C (599 °F). Above this temperature toxic fumes may be given off. Avoid inhalation of fumes or skin contact.

1.9 Tools and consumables

Before starting work ensure that you have suitable tools and/or consumables available. Use only genuine Spirax Sarco replacement parts.

1.10 Protective clothing

Consider whether you and/or others in the vicinity require any protective clothing to protect against the hazards of, for example, chemicals, high/low temperature, radiation, noise, falling objects, and dangers to eyes and face.

1.11 Permits to work

All work must be carried out or be supervised by a suitably competent person.

Installation and operating personnel should be trained in the correct use of the product according to the Installation and Maintenance Instructions.

Where a formal 'permit to work' system is in force it must be complied with. Where there is no such system, it is recommended that a responsible person should know what work is going on and, where necessary, arrange to have an assistant whose primary responsibility is safety.

Post 'warning notices' if necessary.

1.12 Handling

Manual handling of large and/or heavy products may present a risk of injury. Lifting, pushing, pulling, carrying or supporting a load by bodily force can cause injury particularly to the back. You are advised to assess the risks taking into account the task, the individual, the load and the working environment and use the appropriate handling method depending on the circumstances of the work being done.

1.13 Residual hazards

In normal use the external surface of the product may be very hot. If used at the maximum permitted operating conditions the surface temperature of the product may reach temperatures in excess of 400 °C (752 °F).

Many products are not self-draining. Take due care when dismantling or removing the product from an installation (refer to 'Maintenance instructions').

1.14 Freezing

Provision must be made to protect products which are not self-draining against frost damage in environments where they may be exposed to temperatures below freezing point.

1.15 Disposal

Unless otherwise stated in the Installation and Maintenance Instructions, this product is recyclable and no ecological hazard is anticipated with its disposal providing due care is taken. However, special care must be taken to avoid potential health hazards associated with decomposition/burning of the fluorocarbon polymer FEPM (TFEP) 'O' ring:

Fluoroelastomer (Fluorocarbon polymer FEPM (TFEP)):

- Can be landfilled, when in compliance with National and Local regulations.
- Burning is not recommended, unless conducted by an approved/licenced incineration agency.
- Is insoluble in aqueous media.

Please visit the Spirax Sarco product compliance web pages

<https://www.spiraxsarco.com/product-compliance>

for up to date information on any substances of concern that may be contained within this product. Where no additional information is provided on the Spirax Sarco product compliance web page, this product may be safely recycled and/or disposed providing due care is taken. Always check your local recycling and disposal regulations.

1.16 Returning products

Customers and stockists are reminded that under EC Health, Safety and Environment Law, when returning products to Spirax Sarco they must provide information on any hazards and the precautions to be taken due to contamination residues or mechanical damage which may present a health, safety or environmental risk. This information must be provided in writing including Health and Safety data sheets relating to any substances identified as hazardous or potentially hazardous.

2. General product information

2.1 General description

The **DCV10** (cast stainless steel) and **DCV10C** (zinc plated cast carbon steel) are wafer pattern disc check valves that have been designed to be sandwiched between flanges for use with pumps and general cycling applications. They are suitable for use on a wide range of fluids for applications in process lines, hot water systems, steam and condensate systems etc. The centrally guided design ensures improved life span of the unit plus more reliability when compared to traditional disc check valves. These disc check valves will ensure correct flow of condensate and other suitable fluids whilst also preventing reverse flow - maintaining production and profit at all times.

Standards

The DCV10 is designed in accordance with BS EN 14341:2006.

This product fully complies with the requirements of the European Pressure Equipment Directive 2014/68/EU and carries the  marks when so required.

Shut-off

Shut-off conforms to EN 12266-1:2003 Rate F.

Certification

This product is available with certification to EN 10204 3.1.

Note: All certification/inspection requirements must be stated at the time of order placement.

Note: For additional product data see Technical Information Sheet TI-P601-32.

2.2 Sizes and pipe connections

Sizes: DN25, DN32, DN40, DN50, DN65, DN80, DN100, DN125, DN150, DN200 and DN250

PN rated design fits between the following flanges:

DN25 - DN100 EN 1092 PN25, PN16, PN40, JIS/KS 10K and JIS/KS 20K

DN125 - DN250 EN 1092 PN25, PN16, PN40 and JIS/KS 20K

ASME Class 300 design fits between the following flanges:

ASME B 16.5 Class 150 and ASME B 16.5 Class 300.

Face-to-face dimensions are in accordance with:

EN 558 Series 49 for the DN125 - DN200 size range and EN 558 Series 52 for the DN250

DCV10
DN25 - DN100

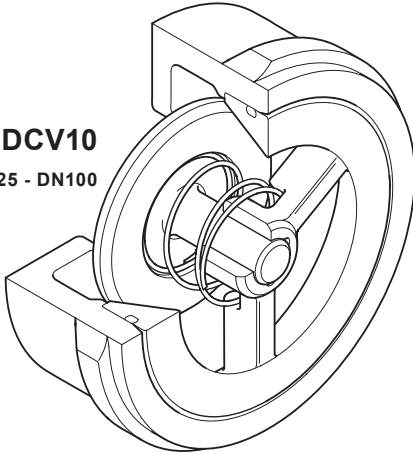

DCV10 and DCV10C
DN125 - DN250

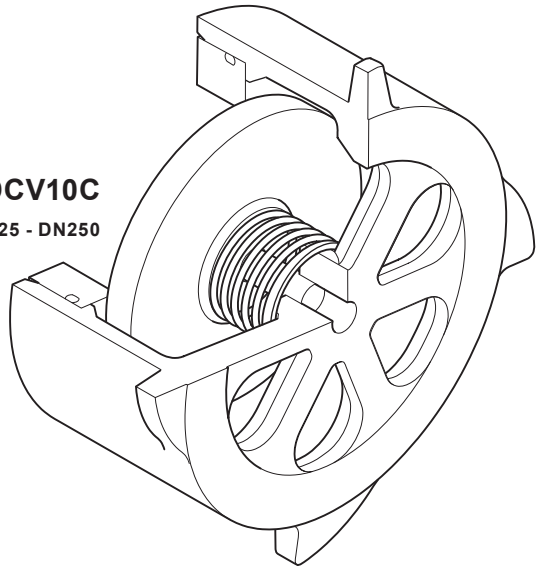
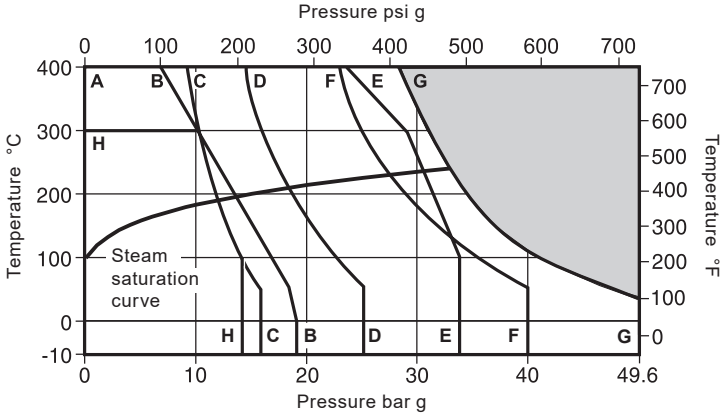

Fig. 1

DCV10 and DCV10C Centrally Guided Disc Check Valves

2.3 Pressure/temperature limits - DCV10 (DN25 - DN100)



The product **must not** be used in this region.

- A - B** Flanged ASME Class 150.
- A - C** Flanged EN 1092 PN16.
- A - D** Flanged EN 1092 PN25.
- A - E** Flanged JIS/KS 20K.
- A - F** Flanged EN 1092 PN40.
- A - G** Flanged ASME Class 300.
- A - H** Flanged JIS/KS 10K.

Body design condition		PN40 or ASME Class 300	
PMA	Maximum allowable temperature	PN40	40 bar g @ 50 °C (580 psi g @ 122 °F)
		ASME Class 300	49.5 bar g @ 38 °C (719 psi g @ 100 °F)
TMA	Maximum allowable temperature	PN40	400 °C @ 23.8 bar g (752 °F @ 345 psi g)
		ASME Class 300	400 °C @ 28.4 bar g (752 °F @ 412 psi g)
Minimum allowable temperature		-10 °C (-14 °F)	
PMO	Maximum operating pressure	PN40	40 bar g @ 50 °C (580 psi g @ 122 °F)
		ASME Class 300	49.5 bar g @ 38 °C (719 psi g @ 100 °F)
TMO	Maximum operating temperature	PN40	400 °C @ 23.8 bar g (752 °F @ 345 psi g)
		ASME Class 300	400 °C @ 28.4 bar g (752 °F @ 412 psi g)
Temperature limits		-10 °C to +400 °C (14 °F to 752 °F)	
Minimum operating temperature		-10 °C (14 °F)	
Designed for a maximum cold hydraulic test pressure of:	PN40	60 bar g (870 psi g)	
	ASME Class 300	74.4 bar g (1079 psi g)	

Product is safe for use under full vacuum conditions

2.4 Pressure/temperature limits - DCV10 (DN125 - DN250)

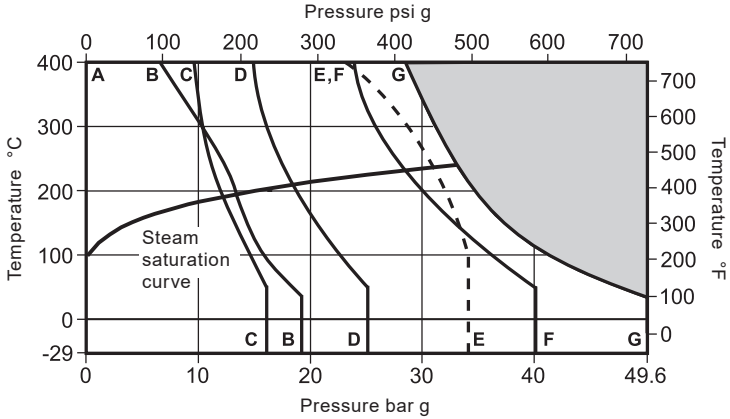

The product **must not** be used in this region.

A - B Flanged ASME Class 150.

A - E Flanged JIS/KS 20K.

A - C Flanged EN 1092 PN16.

A - F Flanged EN 1092 PN40.

A - D Flanged EN 1092 PN25.

A - G Flanged ASME Class 300.

Body design condition	PN40 or ASME Class 300	
PMA	Maximum allowable pressure	49.6 bar g @ 38 °C (791 psi g @ 100 °F)
TMA	Maximum allowable temperature	400 °C @ 28.4 bar g (752 °F @ 412 psi g)
	Minimum allowable temperature	-29 °C (-20 °F)
PMO	Maximum operating pressure for saturated steam service	33 bar g @ 241 °C (478 psi g @ 466 °F)
TMO	Maximum operating temperature	400 °C @ 28.4 bar g (752 °F @ 412 psi g)
	Temperature limits	-29 °C to +400 °C (-20 °F to +752 °F)
	Minimum operating temperature	-29 °C (-20 °F)
	Designed for a maximum cold hydraulic test pressure of:	77 bar g (1 117 psi g)

Product is safe for use under full vacuum conditions

DCV10 and DCV10C Centrally Guided Disc Check Valves

spirax
sarco

2.5 Pressure/temperature limits - DCV10C (DN125 - DN250)

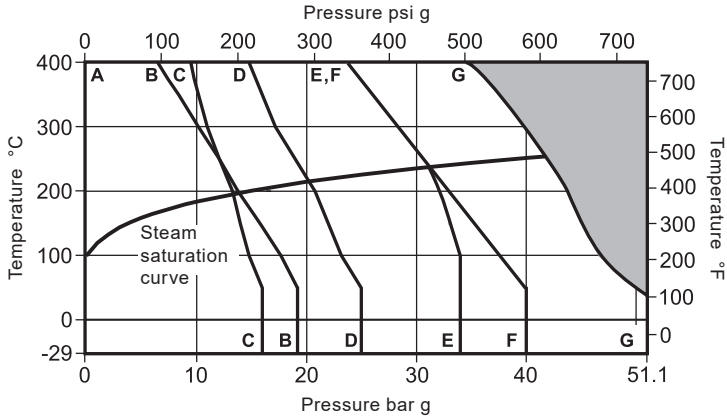

The product **must not** be used in this region.

A - B Flanged ASME Class 150.

A - E Flanged JIS/KS 20K.

A - C Flanged EN 1092 PN16.

A - F Flanged EN 1092 PN40.

A - D Flanged EN 1092 PN25.



A - G Flanged ASME Class 300.

Body design condition		PN40 or ASME Class 300
PMA	Maximum allowable pressure	51.1 bar g @ 38 °C (741 psi g @ 100 °F)
TMA	Maximum allowable temperature	400 °C @ 34.7 bar g (752 °F @ 503 psi g)
Minimum allowable temperature		-29 °C (-20 °F)
PMO	Maximum operating pressure for saturated steam service	42 bar g @ 255 °C (609 psi g @ 491 °F)
TMO	Maximum operating temperature	400 °C @ 34.7 bar g (752 °F @ 503 psi g)
Temperature limits		-10 °C to +400 °C (-20 °F to +752 °F)
Minimum operating temperature		-29 °C (-20 °F)
Designed for a maximum cold hydraulic test pressure of:		77 bar g (1117 psi g)

Product is safe for use under full vacuum conditions

2.6 Product body markings

DCV10 DN125 STAINLESS STEEL

SPIRAX SARCO Made in France 	DN125 DCV10 PN40-CL300	1.4308 TMA 400° A351 CF8 PMA 49.6 bar g EN 14341 Tmin -29 °C	  0525
--	---------------------------	--	--

DCV10C DN150 CARBON STEEL

SPIRAX SARCO Made in France 	DN125 DCV10C PN40-CL300	1.0619+N TMA 400° A216 WCB PMA 51.1 bar g EN 14341 Tmin -29 °C	  0525
--	----------------------------	--	--

3. Installation

Note: Before actioning any installation observe the 'Safety information' in Section 1.

Referring to the Installation and Maintenance Instructions, product markings and Technical Information Sheet, check that the product is suitable for the intended installation:

- 3.1** Check materials, pressure and temperature and their maximum values. If the maximum operating limit of the product is lower than that of the system in which it is being fitted, ensure that a safety device is included in the system to prevent overpressurisation.
- 3.2** Determine the correct installation situation and the direction of fluid flow.
- 3.3** Disc check valves simply fit between two pipe flanges (see Figure 2). Standard gaskets are used either side of the valve together with longer bolts or studs. Note: Flanges, bolts (or studs), nuts and joint gaskets are to be provided by the installer. Normal sensible flange bolting practice should be followed e.g. torque tightening the bolts in opposite sequence.
- 3.4** The DCV10 must be installed close coupled to the pump. It can be fitted in either a horizontal or vertical line in accordance with the direction of flow arrow on the body. **Note:** Flanges, bolts (or studs), nuts and gaskets to be supplied by the installer.

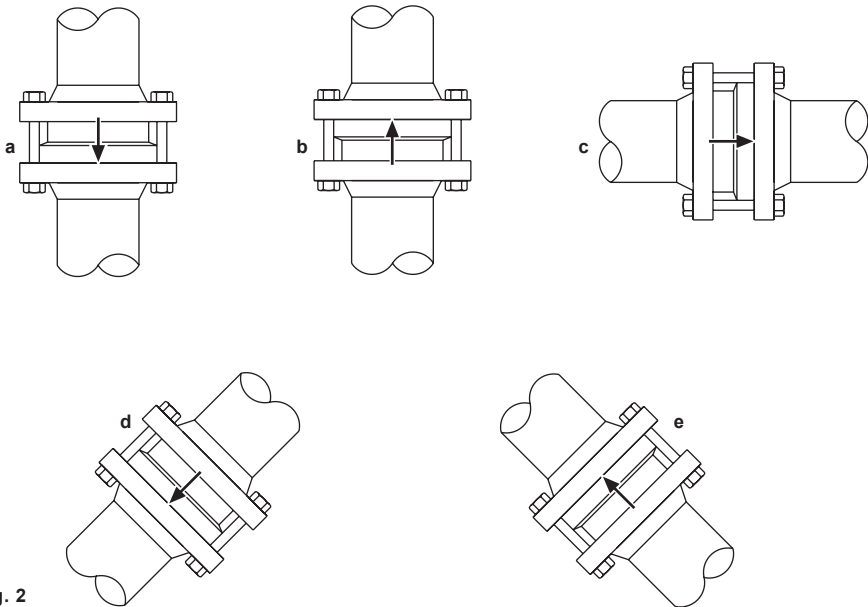

Fig. 2

4. Commissioning

After installation or maintenance ensure that the system is fully functional. Carry out tests on any alarms or protective devices.

5. Operation

Principle of operation

The DCV10 and DCV10C are opened by the pressure and flow of condensate and are closed by the pressure of the spring when the flow ceases and before reverse flow occurs.

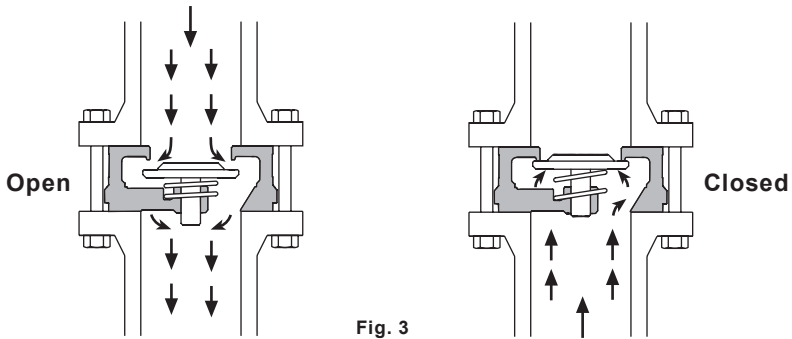

Fig. 3

Kv values

Size	DN25	DN32	DN40	DN50	DN65	DN80	DN100	DN125	DN150	DN200	DN250
Kv	10.8	10.8	26	43	43	80	130	188	213	432	735

For conversion:

$$Cv \text{ (UK)} = Kv \times 0.963$$

$$Cv \text{ (US)} = Kv \times 1.156$$

Opening pressures in mbar

Differential pressures with zero flow.

→ Flow direction

DN	DN25	DN32	DN40	DN50	DN65	DN80	DN100	DN125	DN150	DN200	DN250
↑	25.0	25	28.0	29.0	29	31.0	33	44	46	48.5	54
→	22.5	22.5	24.5	24.5	24.5	25.5	27	32	33	34	37
↓	20.0	20	20.0	20.0	20	30.0	20	20	20	20	20

DCV10 and DCV10C Centrally Guided Disc Check Valves

6. Maintenance

This product is non-maintainable.

7. Spare parts

There are no spare parts available for this product.

How to order a new product

Example:

1 off Spirax Sarco DN80, DCV10 stainless steel check valve to fit between PN16 flanges for use with an MFP14 automatic pump.

