

**DCV1, DCV3, DCV3LT
and DCV3 Food+
Disc Check Valves**

Installation and Maintenance Instructions

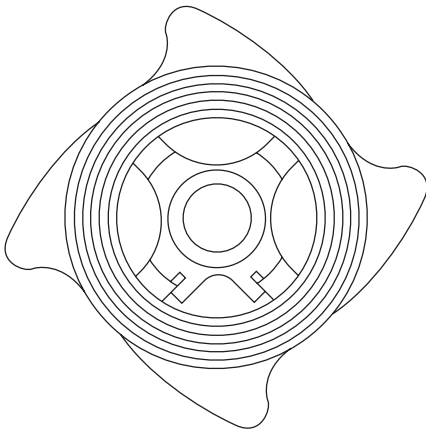

1. Safety information
2. General product information
3. Installation
4. Commissioning
5. Operation
6. Maintenance
7. Spare parts

1. Safety information

Safe operation of these products can only be guaranteed if they are properly installed, commissioned, used and maintained by qualified personnel (see Section 1.11) in compliance with the operating instructions. General installation and safety instructions for pipeline and plant construction, as well as the proper use of tools and safety equipment must also be complied with.

1.1 Intended use

Referring to the Installation and Maintenance Instructions, name-plate and Technical Information Sheet, check that the products are suitable for the intended use/application.

The products listed below comply with the requirements of the European Pressure Equipment

Directive 2014/68/EU and carry the  mark when so required.

The products fall within the following Pressure Equipment Directive category:

Product	Group 2 Gases	Group 2 Liquids
DCV1	DN15 - DN25	SEP
	DN32 - DN50	SEP
	DN65 - DN100	1
DCV3 and DCV3LT	DN15 - DN25	SEP
	DN32	SEP
	DN40 - DN50	1
	DN65 - DN100	1

- i) The product has been specifically designed for use on steam, compressed air and water/ condensate which are in Group 2 of the above mentioned Pressure Equipment Directive.
- ii) Check material suitability, pressure and temperature and their maximum and minimum values. If the maximum operating limits of the product are lower than those of the system in which it is being fitted, or if malfunction of the product could result in a dangerous overpressure or overtemperature occurrence, ensure a safety device is included in the system to prevent such over-limit situations.
- iii) Determine the correct installation situation and direction of fluid flow.
- iv) Spirax Sarco products are not intended to withstand external stresses that may be induced by any system to which they are fitted. It is the responsibility of the installer to consider these stresses and take adequate precautions to minimise them.
- v) Remove protection covers from all connections and protective film from all name-plates, where appropriate, before installation on stream or other high temperature applications.
- vi) Prior to use, the user shall ensure the fluid compatibility with the equipment material.

1.2 Access

Ensure safe access and if necessary a safe working platform (suitably guarded) before attempting to work on the product. Arrange suitable lifting gear if required.

1.3 Lighting

Ensure adequate lighting, particularly where detailed or intricate work is required.

1.4 Hazardous liquids or gases in the pipeline

Consider what is in the pipeline or what may have been in the pipeline at some previous time. Consider: flammable materials, substances hazardous to health, extremes of temperature.

1.5 Hazardous environment around the product

Consider: explosion risk areas, lack of oxygen (e.g. tanks, pits), dangerous gases, extremes of temperature, hot surfaces, fire hazard (e.g. during welding), excessive noise, moving machinery.

1.6 The system

Consider the effect on the complete system of the work proposed. Will any proposed action (e.g. closing isolation valves, electrical isolation) put any other part of the system or any personnel at risk?

Dangers might include isolation of vents or protective devices or the rendering ineffective of controls or alarms. Ensure isolation valves are turned on and off in a gradual way to avoid system shocks.

1.7 Pressure systems

Ensure that any pressure is isolated and safely vented to atmospheric pressure. Consider double isolation (double block and bleed) and the locking or labelling of closed valves. Do not assume that the system has depressurised even when the pressure gauge indicates zero.

1.8 Temperature

Allow time for temperature to normalise after isolation to avoid the danger of burns and consider whether protective clothing (including safety glasses) is required.

Viton seat:

If the Viton seat has been subjected to a temperature approaching 315 °C (599 °F) or higher it may have decomposed and formed hydrofluoric acid. Avoid skin contact and inhalation of any fumes as the acid will cause deep skin burns and damage the respiratory system.

1.9 Tools and consumables

Before starting work ensure that you have suitable tools and/or consumables available. Use only genuine Spirax Sarco replacement parts.

1.10 Protective clothing

Consider whether you and/or others in the vicinity require any protective clothing to protect against the hazards of, for example, chemicals, high/low temperature, radiation, noise, falling objects, and dangers to eyes and face.

1.11 Permits to work

All work must be carried out or be supervised by a suitably competent person. Installation and operating personnel should be trained in the correct use of the product according to the Installation and Maintenance Instructions.

Where a formal 'permit to work' system is in force it must be complied with. Where there is no such system, it is recommended that a responsible person should know what work is going on and, where necessary, arrange to have an assistant whose primary responsibility is safety.

Post 'warning notices' if necessary.

1.12 Handling

Manual handling of large and/or heavy products may present a risk of injury. Lifting, pushing, pulling, carrying or supporting a load by bodily force can cause injury particularly to the back. You are advised to assess the risks taking into account the task, the individual, the load and the working environment and use the appropriate handling method depending on the circumstances of the work being done.

1.13 Residual hazards

In normal use the external surface of the product may be very hot. If used at the maximum permitted operating conditions the surface temperature of some products may reach temperatures of 300 °C (572 °F).

Many products are not self-draining. Take due care when dismantling or removing the product from an installation (refer to 'Maintenance instructions').

1.14 Freezing

Provision must be made to protect products which are not self-draining against frost damage in environments where they may be exposed to temperatures below freezing point.

1.15 Disposal

This product is recyclable. No ecological hazard is anticipated with the disposal of this product providing due care is taken, except:

Viton seat:

- Waste parts can be landfilled, when in compliance with National and Local regulations.
- Parts can be incinerated, but a scrubber must be used to remove Hydrogen Fluoride, which is evolved from the product and with compliance to National and Local regulations.
- Parts are insoluble in aquatic media.

Please visit the Spirax Sarco product compliance web pages

<https://www.spiraxsarco.com/product-compliance>

for up to date information on any substances of concern that may be contained within this product. Where no additional information is provided on the Spirax Sarco product compliance web page, this product may be safely recycled and/or disposed providing due care is taken. Always check your local recycling and disposal regulations.

1.16 Returning products

Customers and stockists are reminded that under EC Health, Safety and Environment Law, when returning products to Spirax Sarco they must provide information on any hazards and the precautions to be taken due to contamination residues or mechanical damage which may present a health, safety or environmental risk. This information must be provided in writing including Health and Safety data sheets relating to any substances identified as hazardous or potentially hazardous.

1.17 DCV3 Food+ version, safety instructions

This product is intended to be connected into a system that can operate an EC1935 compliant process.

To minimise the risk of non-intentionally added substances in the system, it is essential that an appropriate CIP (cleaning in place) cycle is carried out by the end user prior to first use in a food contact application.

A list of the materials that could come directly or indirectly into contact with foodstuffs can be found in the Declaration of Compliance available for this product.

2. General product information

2.1 General description

The DCV1, DCV3 and DCV3LT disc check valves are of the wafer pattern designed to be sandwiched between flanges. They are suitable for use on a wide range of fluids for applications in process lines, hot water systems, steam and condensate systems etc. Face-to-face dimensions conform to EN 558 part 1, series 49. As standard the valves have a metal-to-metal seat. See Section 2.5 for other options which are available on request.

Note: For additional information see Technical Information Sheets TI-P134-05 for the DCV1 or TI-P134-50 for the DCV3 and DCV3LT.

2.2 Sizes and pipe connections

DN15, DN20, DN25, DN32, DN40, DN50, DN65, DN80 and DN100.

Suitable for installation between BS 10 Tables 'E' and 'H'.

EN 1092 PN6, PN10, PN16, PN25 and PN40; JIS 5, JIS 10, JIS 16 and JIS 20 flanges with the following exceptions:

DN40, DN50, DN80 and DN100 - will not fit between JIS 5 flanges.

DN65 and DN80 - will not fit between BS 10 'E' flanges.

2.3 Optional extras

Heavy duty springs (700 mbar [10 psi] opening pressure up to DN65) for boiler feed applications.

Viton soft seats for oil, gas and steam applications.

EPDM soft seats for water applications.

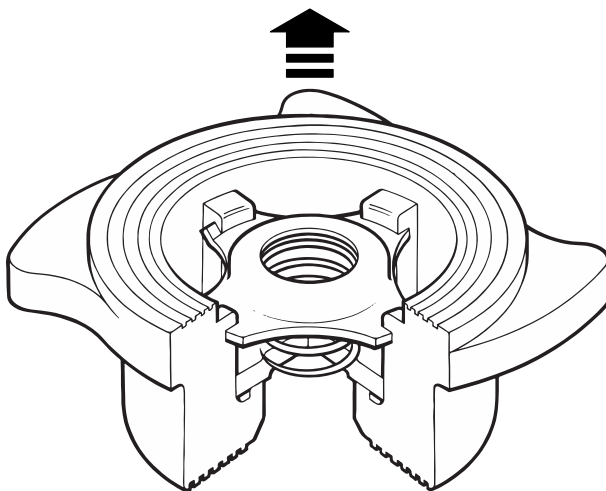

Fig. 1 DCV1, DCV3 and DCV3LT

2.4 Materials

Part	Material	
Body	DCV1	Bronze
	DCV3	Austenitic stainless steel
	DCV3LT	Austenitic stainless steel
Disc	Austenitic stainless steel	
Spring retainer	Austenitic stainless steel	
Standard spring	Austenitic stainless steel	
Heavy duty spring	Austenitic stainless steel	
High temperature spring	Nickel alloy	

2.5 Seating options

The valves are stamped to identify the internals fitted:

'N'	– High temperature spring	– Standard metal disc
'W'	– Without spring	– Standard metal disc
'H'	– Heavy duty spring	– Standard metal disc
'V'	– Standard spring	– Viton soft faced disc
'E'	– Standard spring	– EPDM soft faced disc
'WV'	– Without spring	– Viton soft faced disc
'WE'	– Without spring	– EPDM soft faced disc
'HV'	– Heavy duty spring	– Viton soft faced disc
'HE'	– Heavy duty spring	– EPDM soft faced disc
'T'	– Valves tested to EN 12266 rate D	

No identification indicates a standard spring with a metal disc.

2.6 Pressure/temperature limits - DCV1

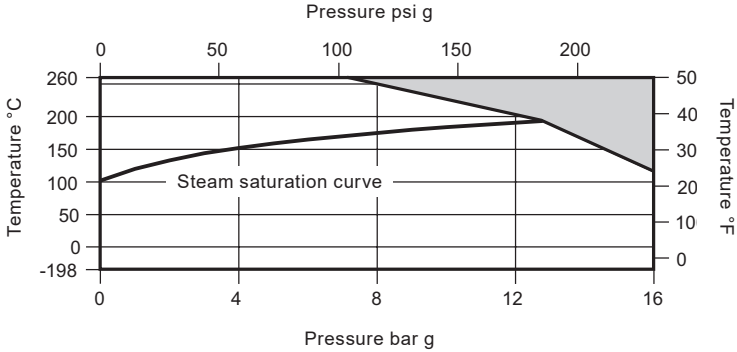

The product **must not** be used in this region.

Please note: The figures displayed are only relevant when a metal-to-metal seat is used. If Viton or EPDM seats are used the product is restricted to the limits of the seat material chosen.

Body design conditions for saturated steam service		PN16	
PMA	Maximum allowable pressure	16 bar g @ 120 °C (232 psi g @ 248 °F)	
TMA	Maximum allowable temperature	260 °C @ 7 bar g (500 °F @ 101 psi g)	
Minimum allowable temperature		-198 °C	(-324 °F)
PMO	Maximum operating pressure for saturated steam service	13.2 bar g @ 196 °C (191 psi g @ 355 °F)	
TMO	Maximum operating temperature	260 °C @ 7 bar g (500 °F @ 101 psi g)	
Minimum operating temperature		-198 °C	(-324 °F)
Note: For lower operating temperatures consult Spirax Sarco			
Temperature limits	Viton seat	-25 °C to +205 °C	(-13 °F to 401 °F)
	EPDM seat	-40 °C to +120 °C	(-40 °F to 248 °F)
Designed for a maximum cold hydraulic test pressure of		24 bar g	(348 psi g)

Note: Special testing to allow lower temperature operation can be provided at extra cost. Consult Spirax Sarco.

2.7 Pressure/temperature limits - DCV3 and DCV3LT

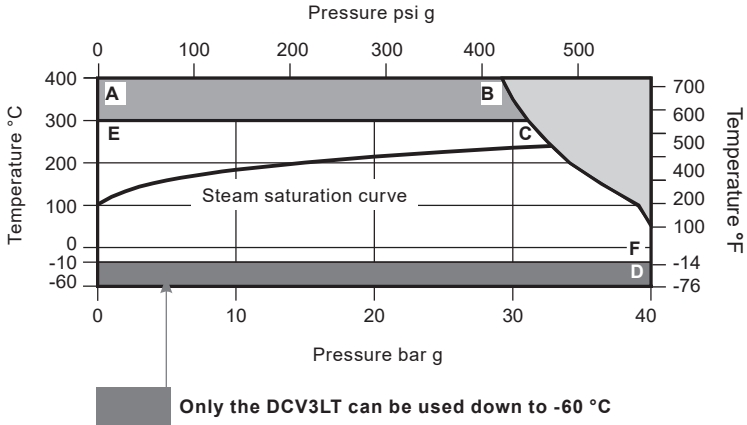

The product **must not** be used in this region.

Use either a DCV3 with high temperature spring or DCV3/DCV3LT without spring for use in this area.

A-B-F DCV3 without spring and with high temperature spring.

A-B-D DCV3LT without spring.

E-C-F DCV3 with standard spring and heavy duty spring.

E-C-D DCV3LT with standard spring and heavy duty spring.

Please note: The figures displayed are only relevant when a metal-to-metal seat is used. If Viton or EPDM seats are used the product is restricted to the limits of the seat material chosen.

Body design conditions			PN40
PMA	Maximum allowable pressure	40 bar g @ 50 °C (580 psi g @ 122 °F)	
TMA	Maximum allowable temperature	400 °C @ 31.2 bar g (752 °F @ 452 psi g)	
Minimum allowable temperature		DCV3	-10 °C (14 °F)
		DCV3LT	-60 °C
PMO	Maximum operating pressure (metal-to-metal seat)	40 bar g @ 50 °C (580 psi g @ 122 °F)	
TMO	Maximum operating temperature	Standard spring	300 °C @ 33.3 bar g (572 °F @ 483 psi g)
		Heavy duty spring	300 °C @ 33.3 bar g (572 °F @ 483 psi g)
		High temperature spring	DCV3 only 400 °C @ 31.2 bar g (752 °F @ 452 psi g)
		Without spring	400 °C @ 31.2 bar g (752 °F @ 452 psi g)
Minimum operating temperature Note: For lower operating temperatures consult Spirax Sarco		DCV3	-10 °C (14 °F)
		DCV3LT	-60 °C
Temperature limits		Viton seat	-25 °C to +205 °C (-13 °F to 401 °F)
		EPDM seat	-40 °C to +120 °C (-40 °F to 248 °F)
Designed for a maximum cold hydraulic test pressure of		60 bar g	(870 psi g)

DCV1, DCV3, DCV3LT and DCV3 Food+ Disc Check Valves

3. Installation

Note: Before actioning any installation observe the 'Safety information' in Section 1.

Referring to the Installation and Maintenance Instructions, name-plate and Technical Information Sheet, check that the product is suitable for the intended installation:

- 3.1** Check materials, pressure and temperature and their maximum values. If the maximum operating limit of the product is lower than that of the system in which it is being fitted, ensure that a safety device is included in the system to prevent overpressurisation.
- 3.2** Determine the correct installation situation and the direction of fluid flow.
- 3.3** Remove protective covers from all connections.
- 3.4** Valves must only be installed where 'weld neck' flanges are used. Other flange types may restrict operation.
- 3.5** Disc check valves simply fit between two pipe flanges (see Fig. 2). Standard gaskets are used either side of the valve together with longer bolts or studs. Note: flanges, bolts (or studs), nuts and joint gaskets to be provided by the installer. Normal sensible flange bolting practice should be followed eg. torque tightening the bolts in opposite sequence.
- 3.6** The DCV1, DCV3 and DCV3LT can be installed in any plane with the exception of DCV's supplied without an internal spring. These must be fitted in a vertical flow line with the flow from bottom-to-top i.e. upward flow (see Fig. 2b). Disc check valves must be fitted in accordance with the direction of the flow arrow on the body, indicating correct fluid flow direction.

Note: Disc check valves are not suitable for use where heavily pulsating flow exists, such as close to a compressor.

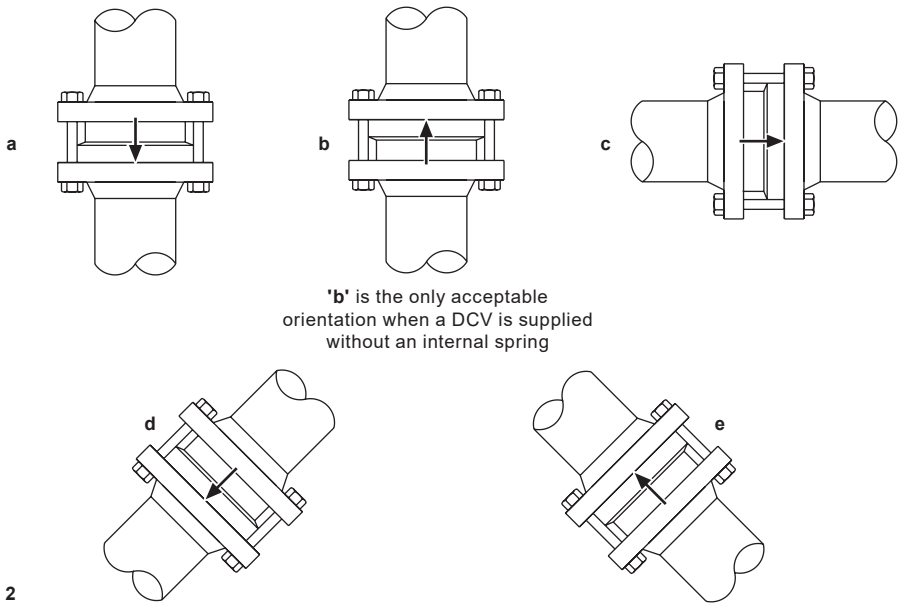

Fig. 2

DCV1, DCV3, DCV3LT and DCV3 Food+ Disc Check Valves

4. Commissioning

After installation or maintenance ensure that the system is fully functional. Carry out tests on any alarms or protective devices.

5. Operation

Disc check valves are opened by the pressure of the fluid and closed by the spring as soon as the flow ceases and before the reverse flow occurs.

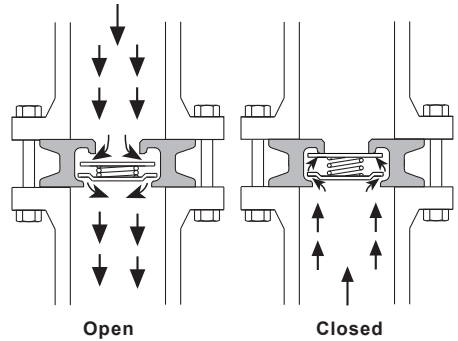

Fig. 3

Kv values

DN	15	20	25	32	40	50	65	80	100
Kv	4.4	6.8	10.8	17	26	43	60	80	113

For conversion:

$$Cv (UK) = Kv \times 0.963$$

$$Cv (US) = Kv \times 1.156$$

Opening pressures in mbar

Differential pressures with zero flow for standard and high temperature springs.

→ Flow direction

DN	15	20	25	32	40	50	65	80	100
↑	25	25	25	27	28	29	30	31	33
→	22.5	22.5	22.5	23.5	24.5	24.5	25	25.5	26.5
↓	20	20	20	20	20	20	20	20	20

Where lowest opening pressures are required, valves without springs can be installed in vertical pipes with bottom-to-top flow.

Without spring

↑	2.5	2.5	2.5	3.5	4	4.5	5	5.5	6.5
---	-----	-----	-----	-----	---	-----	---	-----	-----

Heavy duty springs approximately 700 mbar

DCV1, DCV3, DCV3LT and DCV3 Food+ Disc Check Valves

6. Maintenance

Note: Before actioning any maintenance programme observe the 'Safety information' in Section 1.

This product is non-maintainable.

Note: Great care must be taken if a DCV with a heavy duty spring is taken apart since the strength of the spring can cause the retainer to spring out of the body.

7. Spare parts

There are no spare parts available for this product.

How to order a new product

Example: 1 off Spirax Sarco DN25, DCV3 Austenitic stainless steel disc check valve for fitting between DN25, PN40 flanges.

