

CVS10

Sanitary Check Valves

Installation and Maintenance Instructions

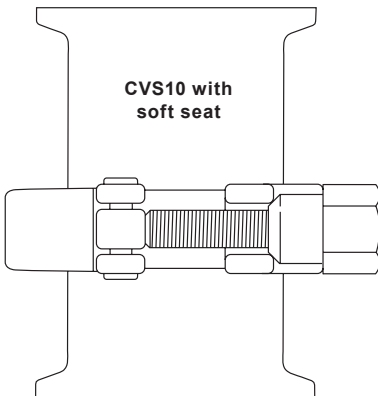

1. Safety information
2. General product information
3. Operation
4. Installation
5. Commissioning
6. Spare parts and maintenance

1. Safety information

Safe operation of this product can only be guaranteed if it is properly installed, commissioned, used and maintained by qualified personnel (see Section 1.11) in compliance with the operating instructions. General installation and safety instructions for pipeline and plant construction, as well as the proper use of tools and safety equipment must also be complied with.

1.1 Intended use

Referring to the Installation and Maintenance Instructions, body markings and Technical Information Sheet, check that the product is suitable for the intended use/application.

The product listed below complies with the requirements of the European Pressure Equipment Directive 2014/68/EU and carries the  mark when so required.

It should be noted that products rated as 'SEP' are required by the Directive not to carry the  mark.

The product falls within the following Pressure Equipment Directive categories:

Product	Gases Group 2	Fluids Group 2
CVS10 sanitary check valve	SEP	SEP

- i) The CVS10 has been specifically designed for use on steam, process fluids, process gases or water/condensate which are in Group 2 of the above mentioned Pressure Equipment Directive. The products' use on other fluids may be possible but, if this is contemplated, Spirax Sarco should be contacted to confirm the suitability of the product for the application being considered.
- ii) Check material suitability, pressure and temperature and their maximum and minimum values. If the maximum operating limits of the product are lower than those of the system in which it is being fitted, or if malfunction of the product could result in a dangerous overpressure or overtemperature occurrence, ensure a safety device is included in the system to prevent such over.
- iii) Determine the correct installation situation and direction of fluid flow. For applications that are self-draining they must be with the flow vertically downwards.
- iv) Spirax Sarco products are not intended to withstand external stresses that may be induced by any system to which they are fitted. It is the responsibility of the installer to consider these stresses and take adequate precautions to minimise them.
- v) Remove protective covers from all connections and protective film from all name-plates, where appropriate, before installation on steam or other high temperature applications.

1.2 Access

Ensure safe access and if necessary a safe working platform (suitably guarded) before attempting to work on the product. Arrange suitable lifting gear if required.

1.3 Lighting

Ensure adequate lighting, particularly where detailed or intricate work is required.

1.4 Hazardous liquids or gases in the pipeline

Consider what is in the pipeline or what may have been in the pipeline at some previous time. Consider: flammable materials, substances hazardous to health, extremes of temperature.

1.5 Hazardous environment around the product

Consider: explosion risk areas, lack of oxygen (e.g. tanks, pits), dangerous gases, extremes of temperature, hot surfaces, fire hazard (e.g. during welding), excessive noise, moving machinery.

1.6 The system

Consider the effect on the complete system of the work proposed. Will any proposed action (e.g. closing isolation valves, electrical isolation) put any other part of the system or any personnel at risk?

Dangers might include isolation of vents or protective devices or the rendering ineffective of controls or alarms. Ensure isolation valves are turned on and off in a gradual way to avoid system shocks.

1.7 Pressure systems

Ensure that any pressure is isolated and safely vented to atmospheric pressure.

Consider double isolation (double block and bleed) and the locking or labelling of closed valves. Do not assume that the system has depressurised even when the pressure gauge indicates zero.

1.8 Temperature

Allow time for temperature to normalise after isolation to avoid the danger of burns and consider whether protective clothing (including safety glasses) is required.

Viton body seal

If the Viton components have been subjected to a temperature approaching 315 °C (599 °F) or higher they may have decomposed and formed hydrofluoric acid. Avoid skin contact and inhalation of any fumes as the acid will cause deep skin burns and damage the respiratory system.

1.9 Tools and consumables

Before starting work ensure that you have suitable tools and/or consumables available. Use only genuine Spirax Sarco replacement parts.

1.10 Protective clothing

Consider whether you and/or others in the vicinity require any protective clothing to protect against the hazards of, for example, chemicals, high/low temperature, radiation, noise, falling objects, and dangers to eyes and face.

1.11 Permits to work

All work must be carried out or be supervised by a suitably competent person.

Installation and operating personnel should be trained in the correct use of the product according to the Installation and Maintenance Instructions.

Where a formal 'permit to work' system is in force it must be complied with. Where there is no such system, it is recommended that a responsible person should know what work is going on and, where necessary, arrange to have an assistant whose primary responsibility is safety.

Post 'warning notices' if necessary.

1.12 Handling

Manual handling of large and/or heavy products may present a risk of injury. Lifting, pushing, pulling, carrying or supporting a load by bodily force can cause injury particularly to the back. You are advised to assess the risks taking into account the task, the individual, the load and the working environment and use the appropriate handling method depending on the circumstances of the work being done.

1.13 Residual hazards

In normal use the external surface of the product may be very hot. If used at the maximum permitted operating conditions the surface temperature of some products will exceed temperatures of 100 °C (212 °F).

Many products are not self-draining. Take due care when dismantling or removing the product from an installation (refer to 'Maintenance instructions').

1.14 Freezing

Provision must be made to protect products which are not self-draining against frost damage in environments where they may be exposed to temperatures below freezing point.

1.15 Disposal

The product is recyclable. No ecological hazard is anticipated with the disposal of this product providing due care is taken, EXCEPT:

Viton body seal:

- In compliance with National and Local regulations waste parts can be landfilled.
- Waste parts can be incinerated, but a scrubber must be used to remove Hydrogen Fluoride, which is evolved from the product and with compliance to National and Local regulations.
- Is insoluble in aquatic media.

Please visit the Spirax Sarco product compliance web pages

<https://www.spiraxsarco.com/product-compliance>

for up to date information on any substances of concern that may be contained within this product. Where no additional information is provided on the Spirax Sarco product compliance web page, this product may be safely recycled and/or disposed providing due care is taken. Always check your local recycling and disposal regulations.

1.16 Returning products

Customers and stockists are reminded that under EC Health, Safety and Environment Law, when returning products to Spirax Sarco they must provide information on any hazards and the precautions to be taken due to contamination residues or mechanical damage which may present a health, safety or environmental risk. This information must be provided in writing including Health and Safety data sheets relating to any substances identified as hazardous or potentially hazardous.

2. General product information

2.1 Description

The CVS10 sanitary in-line spring assisted check valve range are manufactured from 316L stainless steel and prevent reverse flow in fluid lines. They are available with either soft seats for process gasses and liquids, or with a metal seat for use within steam systems. They are suitable for a wide range of high purity applications in the food, medical, and pharmaceutical industries. For use with other medium please consult Spirax Sarco.

Available types and surface finish:

CVS10-1 has an internal surface finish of 0.5 micron Ra (within ASME BPE SF1), and external surface finish of 0.8 micron Ra.

CVS10-2 has an electropolished internal surface finish of 0.38 Ra (within ASME BPE SF4), and external surface finish of 0.8 micron Ra.

In addition both the **CVS10-1** and **CVS10-2** are available with either **EPDM**, **Viton** or **FEP-Silicone** soft seats for process gasses and liquids, or with a metal seat for use within steam systems. The soft seated models have a suffix to denote which seat is fitted:

'**E**' for EPDM, '**F**' for FEP-Silicone or '**V**' for Viton.

For example, the model reference **CVS10-2E** denotes a **CVS10** with electropolished internal finish and EPDM soft seat.

Standards:

- The CVS10 fully complies with the European Pressure Equipment Directive 2014/68/EU.
- All wetted elastomers/polymers comply with FDA regulation CFR 21, paragraph 177, section 2600 for EPDM and Viton and section 1550 for FEP-Silicone and TFM PTFE.
- The CVS10 is designed in accordance with ASME-BPE.

Certification

This product is available with the following certification:

- EN 10204 3.1 material certification as standard.
- Typical surface finish certificates.
- FDA approval certificates for elastomers.
- USP class VI approval certificates.
- ADI free certificate.

Note: All certification/inspection requirements must be stated at the time of order placement.

Packaging

Packaging for this product is conducted in a clean environment, segregated from other non stainless steel products, and in accordance with the current edition of ASME BPE. Inlet and outlet connections are capped and the product is sealed in a plastic bag prior to boxing.

Note: For further information see the following Technical Information sheets: TI-P029-10 for the **CVS10 with soft seat** or TI-P029-21 for the **CVS10 with metal seat**.

2.2 Sizes and pipe connections

1/2", 3/4", 1", 1 1/2" and 2" to ASME BPE available as standard.
DN15 to DN50 to DIN 32676 available as standard.

Sanitary clamp:

- ASME BPE clamp.
- Sanitary clamp to DIN 32676.

Note: Alternative connections and sizes are available on request.

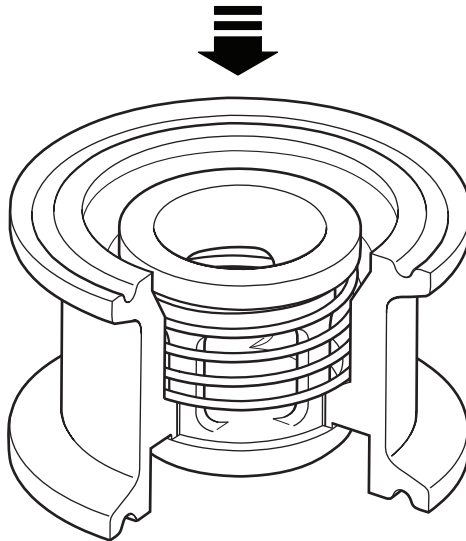
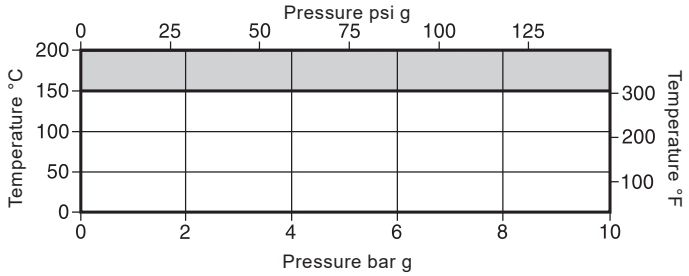

Fig. 1 CVS10 with metal seat and sanitary clamp

2.3 Pressure/temperature limits

CVS10 with soft seat



CVS10 with metal seat

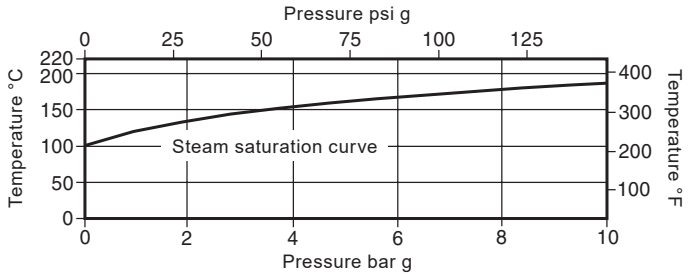

The CVS10 with EPDM seats **must not** be used in this region.

Body design conditions			PN10		
PMA	Maximum allowable pressure	CVS10 with soft seat	Viton	10 bar g @ 200 °C	(145 psi g @ 392 °F)
			FEP-Silicone	10 bar g @ 200 °C	(145 psi g @ 392 °F)
			EPDM	10 bar g @ 150 °C	(145 psi g @ 302 °F)
		CVS10 with metal seat	10 bar g @ 220 °C	(145 psi g @ 428 °F)	
TMA	Maximum allowable temperature	CVS10 with soft seat	Viton	200 °C @ 10 bar g	(392 °F @ 145 psi g)
			FEP-Silicone	200 °C @ 10 bar g	(392 °F @ 145 psi g)
			EPDM	150 °C @ 10 bar g	(302 °F @ 145 psi g)
		CVS10 with metal seat	220 °C @ 10 bar g	(428 °F @ 145 psi g)	
Minimum allowable temperature		CVS10 with soft seat		-20 °C	(-4 °F)
		CVS10 with metal seat		-254 °C	(-435 °F)
PMO	Maximum operating pressure for saturated steam service		10 bar g		(145 psi g)
TMO	Maximum operating temperature	CVS10 with soft seat	Viton	200 °C @ 10 bar g	(392 °F @ 145 psi g)
			FEP-Silicone	200 °C @ 10 bar g	(392 °F @ 145 psi g)
			EPDM	150 °C @ 10 bar g	(302 °F @ 145 psi g)
		CVS10 with metal seat	220 °C @ 10 bar g	(428 °F @ 145 psi g)	
Minimum operating temperature			0 °C		(32 °F)
Designed for a maximum cold hydraulic test pressure of:			15 bar g		(217 psi g)

CVS10 Sanitary Check Valves



3. Operation

The valve is opened by the pressure of the fluid (Figure 2).
 When fluid flow stops the spring closes the valve before reverse flow can occur (Figure 3).

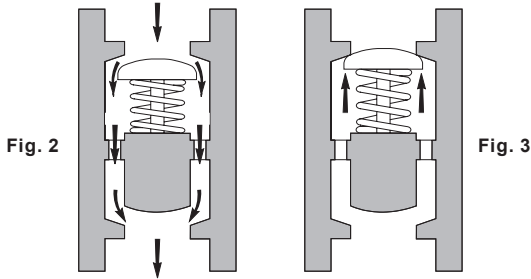

3.1 Opening pressures

Differential pressure with zero flow in mbar

Soft seated versions

Flow direction →

Size	½"	¾"	1"	1½"	2"
→	35	35	35	35	35
↑	39	39	41	43	43
↓	31	31	29	27	27

Metal seated versions

Flow direction →

Size	½"	¾"	1"	1½"	2"
→	35	35	35	35	35
↑	39	39	39	39	39
↓	31	31	31	31	31

3.2 Kv values

Size	½"	¾"	1"	1½"	2"	For conversion: Cv (UK) = Kv x 0.963 Cv(US) = Kv x 1.156
CVS10 with soft seat	8.2	8.2	17.3	27.3	40.5	
CVS10 with metal seat	2.0	2.0	4.0	8.0	18.0	

4. Installation

Before actioning any installation, observe the 'Safety information' in Section 1.

Referring to the Installation and Maintenance Instructions, body markings and Technical Information Sheet, check that the product is suitable for the intended installation:

- 4.1** Check materials, pressure and temperature and their maximum values. If the maximum operating limit of the product is lower than that of the system in which it is being fitted, ensure that a safety device is included in the system to prevent overpressurisation.
- 4.2** Determine the correct installation situation and the direction of flow.
- 4.3** Remove protective covers from all connections and protective film from all name-plates, where appropriate, before installation on steam or other high temperature applications.
- 4.4** The CVS10 can be fitted in both horizontal and vertical lines. For applications that are self-draining it must be installed in such a way that the flow is vertical downwards.
- 4.5** Fittings, clamps and gaskets for the connecting tubing are not supplied.

Note: This product must be handled carefully to ensure that the surface finish is not damaged.

5. Commissioning

After installation or maintenance ensure that the system is fully functioning. Carry out tests on any alarms or protective devices.

Note: If installed on a steam/condensate system, it is very important that the pressure is built up slowly to avoid possible damage to the unit.

6. Spare parts and maintenance

Note: Before actioning any maintenance, observe the 'Safety information' in Section 1

Before undertaking any maintenance on this product, it must be isolated from the supply and return lines and any pressure allowed to normalise to atmosphere. The unit should then be allowed to cool.

6.1 Spare parts

The CVS10 sanitary in-line spring assisted check valve range are manufactured from 316L stainless steel and prevent reverse flow in fluid lines. They are available with either soft seats for process gasses and liquids, or with a metal seat for use within steam systems. They are suitable for a wide range of high purity applications in the food, medical, and biopharmaceutical industries. For use with other medium please consult Spirax Sarco.

Note: The **CVS10-1 with metal seat** and **CVS10-2 with metal seat** are non maintainable - There are no spare parts available.

Available spares

Seal kit

4 and 7

How to order spares

Always order spares by using the description given in the column headed 'Available spares' and state the size and type of check valve.

Example: 1 off Seal kit for a 1" Spirax Sarco CVS10-1E sanitary check valve with EPDM seat having ASME BPE clamp ends.

6.2 How to renew the internals - Soft seated versions only:

- Ensure that the system has cooled and any system pressure has been relieved before dismantling the product.
- Dismantle the inlet and outlet connectors and remove the complete valve from the system.
- Remove the central body clamp fitting (8) and separate the two parts of the check valve (1 and 2)
- Remove the valve head (3) and spring (5) and then remove the valve seat (4) from the valve head (3). Replace the valve seat (4) with a new one making sure it is not damaged during the process.
- Remove the valve guide and bush (6) and clean if required.
- Assemble the valve head (3) (including seal (4)) and spring (5) into the valve guide (6) and place in the body (2).
- Replace all body seals (7) and then replace the body clamp (8) and tighten.

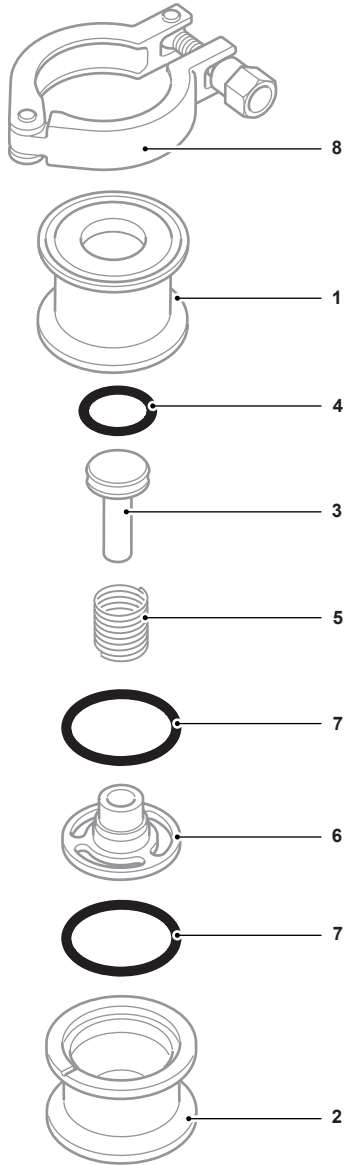

Fig. 4 CVS10-1E with soft seat and sanitary clamp

