CSM-E Electrical Compact Clean Steam Generator

Installation and Maintenance Instructions



1. Safety information
2. General product information
3. Installation
4. Commissioning
5. Maintenance
6. Bolt torque procedure
7. Spare parts
8. Fault finding

1. Safety information

1.1 General safety information

Safe operation of this product can only be guaranteed if it is properly installed, commissioned, used and maintained by qualified personnel (see Section 1.2) in compliance with the operating instructions. General installation and safety instructions for pipeline and plant construction, as well as the proper use of tools and safety equipment must also be complied with.

Safety note - Handling precautions

PTFE

Within its working temperature range PTFE is a completely inert material, but when heated to its sintering temperature it gives rise to gaseous decomposition products or fumes, which can produce unpleasant effects if inhaled. The inhalation of these fumes is easily prevented by applying local exhaust ventilation to atmosphere as near to their source as possible.

Smoking should be prohibited in workshops where PTFE is handled because tobacco contaminated with PTFE will during burning give rise to polymer fumes. It is therefore important to avoid contamination of clothing, especially the pockets, with PTFE and to maintain a reasonable standard of personal cleanliness by washing hands and removing any PTFE particles lodged under the fingernails.

VITON

If Viton has been subjected to a temperature approaching 315°C (599°F) or higher it may have decomposed and formed hydrofluoric acid. Avoid skin contact and inhalation of any fumes as the acid will cause deep skin burns and damage the respiratory system.

1.2 Permits to work

All work must be carried out or be supervised by a suitably competent person. Installation and operating personnel should be trained in the correct use of the product according to the Installation and Maintenance Instructions. Where a formal 'permit to work' system is in force it must be complied with. Where there is no such system, it is recommended that a responsible person should know what work is going on and, where necessary, arrange to have an assistant whose primary responsibility is safety. Post 'warning notices' if necessary.

1.3 Limits of responsibility

This Installation, Operation, and Maintenance manual is intended to be as complete and up to date as possible. It covers the installation, operation, and maintenance procedures for Spirax Sarco CSM-E electrical compact clean steam generators.

Spirax Sarco reserves the right to update this manual and other product information concerning installation, operation, and/or maintenance, at any time and without obligation to notify product owners of changes.

Spirax Sarco is not responsible for inaccuracies in specifications, procedures and / or the content of other product literature, supplied by other manufacturers of components used in Spirax Sarco Steam Generators (i.e.: valves, pressure controls, gauges, etc.).

Spirax Sarco uses only top quality components in the construction and control of its steam generators. Spirax Sarco accepts responsibility for complete systems only when it supplies all the components of the system. Otherwise Spirax Sarco accepts responsibility only for those parts that it has supplied, since it has no direct control over other manufacturers or their quality standards.

Note: The symbol  indicates 'warnings'.

	Spirax Sarco is not responsible for injury to personnel or product damage due to the improper installation, operation, and/or maintenance of Spirax Sarco CSM-E compact clean steam generators (see Section 1.1 - General safety information).
---	--

All installation, operation, and maintenance procedures should only be performed by trained/certified personnel. All personnel performing these procedures should completely and carefully read and understand all supplied materials before attempting the procedures. All personnel should pay strict attention to all Notes, Cautions, and Warnings that appear within the procedures detailed in this manual.

1.4 Pressure Equipment Directive (PED) classification

Spirax Sarco CSM-E compact clean steam generators are classified under table 5 of the pressure equipment directive.

Product	Group 2 Gases
CSM-EE, CSM-EG and CSM-EI (without pre-heat tank)	Cat 3
CSM-EF, CSM-EH and CSM-EL (with pre-heat tank)	Cat 3

Other component parts within the package comply with the relevant European directives where necessary, please refer to specific component literature for further details.

1.5 Intended use

Referring to the Installation and Maintenance Instructions, name-plate and Technical Information Sheet, check that the product is suitable for the intended use/application.

The products listed in Section 1.4 comply with the requirements of the European Pressure Equipment Directive 2014/68/EU, carry the  mark when so required and fall within the Pressure Equipment Directive categories stated.

- i) This product has been specifically designed for use on steam, air or condensate, which is in Group 2 of the above mentioned Pressure Equipment Directive (Section 1.4). The product's use on other fluids may be possible but, if this is contemplated, Spirax Sarco should be contacted to confirm the suitability of the product for the application being considered.
- ii) Check material suitability, pressure and temperature and their maximum and minimum values. If the maximum operating limits of the product are lower than those of the system in which it is being fitted, or if malfunction of the product could result in a dangerous overpressure or overtemperature occurrence, ensure a safety device is included in the system to prevent such over-limit situations.
- iii) Determine the correct installation situation and direction of fluid flow.
- iv) Spirax Sarco products are not intended to withstand external stresses that may be induced by any system to which they are fitted. It is the responsibility of the installer to consider these stresses and take adequate precautions to minimise them.
- v) Remove protection covers from all connections and protective film from all name-plates, where appropriate, before installation on steam or other high temperature applications.

1.6 Access

Ensure safe access and if necessary a safe working platform (suitably guarded) before attempting to work on the product. Arrange suitable lifting gear if required.

1.7 Lighting

Ensure adequate lighting, particularly where detailed or intricate work is required.

1.8 Hazardous liquids or gases in the pipeline

Consider what is in the pipeline or what may have been in the pipeline at some previous time. Consider: flammable materials, substances hazardous to health, extremes of temperature.

1.9 Hazardous environment around the product

Consider: explosion risk areas, lack of oxygen (e.g. tanks, pits), dangerous gases, extremes of temperature, hot surfaces, fire hazard (e.g. during welding), excessive noise, moving machinery.

1.10 The system

Consider the effect on the complete system of the work proposed. Will any proposed action (e.g. closing isolation valves, electrical isolation) put any other part of the system or any personnel at risk?

Dangers might include isolation of vents or protective devices or the rendering ineffective of controls or alarms. Ensure isolation valves are turned on and off in a gradual way to avoid system shocks.

1.11 Pressure systems

Ensure that any pressure is isolated and safely vented to atmospheric pressure. Consider double isolation (double block and bleed) and the locking or labelling of closed valves. Do not assume that the system has depressurised even when the pressure gauge indicates zero.

1.12 Temperature

Allow time for temperature to normalise after isolation to avoid the danger of burns and consider whether protective clothing (including safety glasses) is required.

PTFE seals - If seals made from PTFE have been subjected to a temperature approaching 260°C (500°F) or higher, they will give off toxic fumes, which if inhaled are likely to cause temporary discomfort. It is essential for a no smoking rule to be enforced in all areas where PTFE is stored, handled or processed as persons inhaling the fumes from burning tobacco contaminated with PTFE particles can develop 'polymer fume fever'.

VITON seals - If the Viton seat has been subjected to a temperature approaching 315°C (599°F) or higher it may have decomposed and formed hydrofluoric acid.

Avoid skin contact and inhalation of any fumes as the acid will cause deep skin burns and damage the respiratory system.

1.13 Tools and consumables

Before starting work ensure that you have suitable tools and/or consumables available. Use only genuine Spirax Sarco replacement parts.

1.14 Protective clothing

Consider whether you and/or others in the vicinity require any protective clothing to protect against the hazards of, for example, chemicals, high/low temperature, radiation, noise, falling objects, and dangers to eyes and face.

1.15 Handling

Manual handling of large and/or heavy products may present a risk of injury. Lifting, pushing, pulling, carrying or supporting a load by bodily force can cause injury particularly to the back. You are advised to assess the risks taking into account the task, the individual, the load and the working environment and use the appropriate handling method depending on the circumstances of the work being done.

1.16 Residual hazards

In normal use the external surface of the product may be very hot. If used at the maximum permitted operating conditions the surface temperature of some products may reach temperatures of 185°C (365°F).

Many products are not self-draining. Take due care when dismantling or removing the product from an installation (refer to 'Maintenance instructions').

1.17 Freezing

Provision must be made to protect products, which are not self-draining against frost damage in environments where they may be exposed to temperatures below freezing point.

1.18 Disposal

This product may contain PTFE and Viton, special care must be taken to avoid potential health hazards associated with decomposition/burning of these materials. With the exception of the seal materials unless otherwise stated in the Installation and Maintenance Instructions, this product is recyclable and no ecological hazard is anticipated with its disposal providing due care is taken. However, all components should be checked individually to ensure they can be disposed of safely.

PTFE:

- Can only be disposed of by approved methods, not incineration.
- Keep PTFE waste in a separate container, do not mix it with other rubbish, and consign it to a landfill site.

Viton:

- Waste parts can be landfilled, when in compliance with National and Local regulations.
- Parts can be incinerated, but a scrubber must be used to remove Hydrogen Fluoride, which is evolved from the product and with compliance to National and Local regulations.
- Parts are insoluble in aquatic media.

Please visit the Spirax Sarco product compliance web pages

<https://www.spiraxsarco.com/product-compliance>

for up to date information on any substances of concern that may be contained within this product. Where no additional information is provided on the Spirax Sarco product compliance web page, this product may be safely recycled and/or disposed providing due care is taken. Always check your local recycling and disposal regulations.

1.19 Returning products

Customers and stockists are reminded that under EC Health, Safety and Environment Law, when returning products to Spirax Sarco they must provide information on any hazards and the precautions to be taken due to contamination residues or mechanical damage which may present a health, safety or environmental risk.

This information must be provided in writing including Health and Safety data sheets relating to any substances identified as hazardous or potentially hazardous.

2. General product information

2.1 Description

The CSM-E range of compact clean steam generators are configured and manufactured to use electricity as the energy source for generating clean steam (HTM 2031). They have been designed to generate clean steam for sterilising and humidifying applications from suitably treated water by using electricity as the heating medium, incorporating an integral feedwater pre-heating and degassing system (optional).

The CSM-E range of generators are capable of producing outputs from 50 kg/h up to 150 kg/h at 3 bar g. Each unit comes complete and ready to produce clean steam once connected to the available services.

Construction

All components and materials included in the manufacture of CSM-E electrical compact clean steam generators have been specifically selected to meet the individual design specifications of each unit and HTM 2031. All parts in contact with generated steam are stainless steel 316L. The CSM-E range of compact clean steam generators are, as standard, equipped with an approved safety valve and an external drain, providing a means to remove accumulated sediment.

Spirax Sarco supplies all of the components to control the CSM-E electrical compact clean steam generators which are manufactured to the highest quality.

Standards

These units are designed to meet or exceed all applicable V.S.R code (Vessel Security Rules) regulations and all the pressure components used to make the unit fully comply with the European Pressure Equipment Directive 2014/68/EU.

Note: For additional information see Technical Information Sheet TI-P486-16.

2.2 Controls

Spirax Sarco CSM-E range of compact clean steam generators are equipped with electronically and pneumatically activated controls to regulate pressure (temperature) and water level. The electronic PLC control panel used has a power requirement of 400 volt three phase. In most cases where pneumatically activated controls are used, they require an instrument air pressure supply of 6 bar g (90 psi g) - Consult the individual design specifications for the unit and controls for the exact requirements.

2.3 Versions and outputs

GENERATOR WITHOUT PRE-HEAT TANK			
Unit	CSM-EE	CSM-EG	CSM-EI
Electrical resistance heating power	50 kW	100 kW	110 kW
Clean steam flowrate at 3 bar g	50 kg/h	100 kg/h	135 kg/h

GENERATOR WITH PRE-HEAT TANK			
Unit	CSM-EF	CSM-EH	CSM-EL
Electrical resistance heating power	35 kW (GV)* 15 kW (tank)	100 kW (GV)* 15 kW (tank)	110 kW (GV)* 15 kW (tank)
Clean steam flowrate at 3 bar g	50 kg/h	110 kg/h	150 kg/h

Notes:

1. GV denotes Generator Vessel *.

2. Flowrates and pressures stated are for feedwater temperatures $\geq 18^{\circ}\text{C}$. Each unit can provide clean steam at different flowrates and pressures, please contact Spirax Sarco for any special requirements.

2.4 Name-plates

A name-plate, mounted to the generator body, bears the model and serial numbers of the steam generator unit, whilst a name-plate mounted on the skid bears the package number with **CE** approval (Figure 1).



These numbers should be included in all correspondence regarding the unit.



Fig. 1

Package name-plate

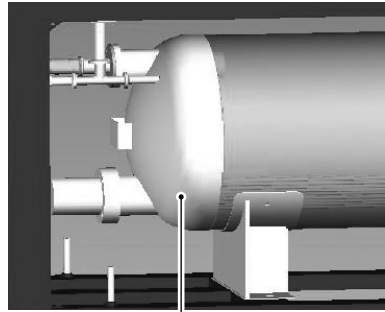

Generator name-plate

2.5 Insulation

The Spirax Sarco CSM-E range of compact clean steam generators have insulation on the feedwater tank (if fitted), generator shell and pipework.

2.6 Heat exchanger

The heating coil (electric element) and the connection piece used to mount the coil in the generator vessel and preheating tank (if fitted) are constructed from AISI 316L stainless steel.

2.7 Warranty information

All components used in the manufacture of Spirax Sarco CSM-E electrical compact clean steam generators are warranted for one (1) year from commissioning or eighteen (18) months from the date of delivery, whichever comes first. In some cases, extended warranties are available on an individual basis, at extra cost.

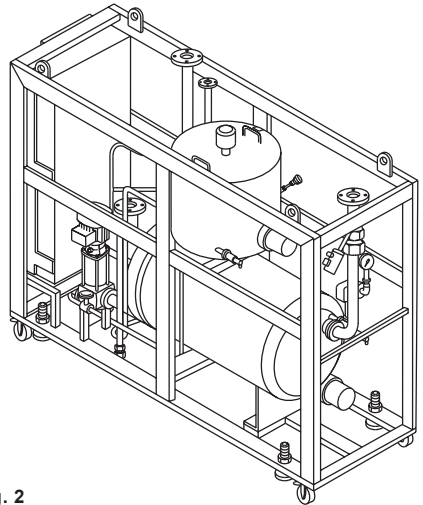

Fig. 2

3. Installation

3.1 General notes

- This manual is intended to cover installation, operation, and maintenance procedures for Spirax Sarco CSM-E compact clean steam generators. If specific installation, operation, and/or maintenance procedures are not clearly understood, contact Spirax Sarco for clarification before proceeding.
- All installation, operation, and maintenance procedures should only be performed by experienced, trained, and qualified personnel. Personnel should be trained in correct piping and electrical procedures and methods, and should be experienced in working with steam and thermal oil / superheated water systems. The Spirax Sarco CSM-E range of compact clean steam generators are designed for indoor use only, unless otherwise required by design specifications. Each unit requires at least one metre clearance at the front and rear, and 500 mm above the unit. It should be located on a level surface (no more than one-half degree [$1/2^\circ$] of slope), capable of supporting the total weight of the unit when filled to capacity. The unit should be mounted to the floor following applicable architectural and local code requirements for the specific installation site. In areas prone to seismic activity, it is recommended that the unit be mounted to the floor according to recommended procedures and codes for the site/location, to make the units less susceptible to seismic damage.
- Maintenance procedures are detailed in Section 5.
- Fault finding procedures are detailed in Section 8.
- The Spirax Sarco CSM-E range of electrical compact clean steam generators are supplied for a range of operating pressures and flowrates. For the specific range of your unit, refer to the design specifications and the accompanying literature and drawings that are supplied with the unit.
- Should the unit be damaged during installation, operation, or maintenance, complete the following steps:
 1. Turn off the power to the unit.
 2. Turn off the clean steam outlet valve (if present).
 3. Turn off the feedwater inlet valves.
 4. Contact in-house maintenance personnel.
- All pipework connections for clean steam and water should be flanged or sanitary type in design, the type of gasket material should be suitable for clean steam applications.

3.2 Warnings

Listed on the following pages are specific warnings pertaining to Spirax Sarco CSM-E electrical clean steam generators. In addition, throughout this manual, warnings are restated when procedures are described pertaining to areas of potential danger. All warnings should be carefully read and understood. All precautions contained in the warnings should be carefully followed to reduce the chance of injury.



Areas of potential danger:

1. All steam water lines, joints and valves;
2. All power connections and cables;
3. All pneumatic (instrument air) lines and joints.



Before attempting any installation, operation, or maintenance procedures pertaining to the unit:

1. If the unit has been in operation, allow the clean steam and water in the tank, as well as all components and surfaces (clean steam outlet lines, feedwater tank outlet lines [if pre-heated], etc.) to cool;
2. Ensure that all power has been shut off / disconnected;
3. Ensure that steam outlet and feedwater inlet lines have been isolated at the manual shut-off valves;
4. Ensure that the pneumatic (instrument air) source has been isolated and the pressure bled from the lines.



Operating conditions can be very dangerous due to the fact that the steam is under pressure and at very high temperatures.

To avoid possible injury or death, follow all accepted and recommended procedures when performing installation, operation, and maintenance procedures.



The combination of electricity and water can pose a very dangerous situation.

Ensure that all power has been shut off / disconnected before attempting any installation or maintenance procedures.

3.3 Product features and specifications

The CSM-E range of compact steam generators, using heating coils (electric elements), are the most economical method of producing clean steam when electricity is used as the energy source. All of the Spirax Sarco CSM-E electrical compact clean steam generators are packaged ready for installation. All components are sized, mounted, piped, and tested prior to shipment. Each unit is built to exact design specifications and requires only connection to energy, water, power, safety discharge, blowdown discharge and/or pneumatic sources to be ready for operation. The packaged concept provides a compact size that is ideal for new installations, or for use as the replacement of an existing steam generator(s). The compact size requires less space for installation. Each unit employs a generator vessel and feedwater heating tank (optional). All components used in the unit are of the highest quality and meet all design requirements. Each unit is supplied with all relevant documentation, inclusive of each major component, to perform Installation, operation and maintenance procedures. If any of these documents are missing, contact either Spirax Sarco or your authorised sales representative before attempting any installation, operation, or maintenance procedure.

3.4 Installation transporting and unpacking the unit

CSM-E compact clean steam generators are usually shipped uncrated, the units can be lifted by means of a forklift truck, placing the forks on the underside of the frame structure, in a central position thus evenly distributing the weight of the unit and providing a stable, balanced load, refer to Figure 3.

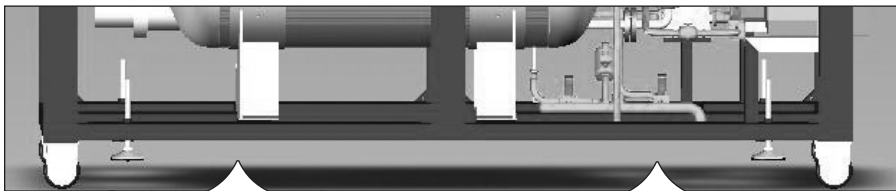

Fig. 3

Place the forks of the forklift truck here

Place the forks of the forklift truck here



If crated when shipped, the unit should only be lifted at the areas indicated on the crate. Improper lifting of the unit may result in damage to the unit.

3.5 Location requirements

The CSM-E range of compact clean steam generators are designed for indoor use only, unless otherwise required by the design specifications. The unit should be located on a level surface (no more than one-half degree [$\frac{1}{2}^\circ$] of slope), capable of supporting the total weight of the unit when filled to capacity. If crated when shipped, the crating should be carefully removed. The unit can then be manoeuvred into place using the mounted wheels (optional), safely installed and then secured using the four foot mounts (standard).

3.6 Examining the unit

After the unit has been set in place, it should be carefully examined to ensure that neither the main unit or any of the components have been damaged during shipping. If any evidence of damage is detected, contact Spirax Sarco or your authorised sales representative, to report the damage and to receive instructions on how best to proceed. After the unit and all components have been inspected for damage, it is suggested that all pressure and control components be checked to ensure that they are to design specifications. This can be done by reviewing the design specifications (included with the unit) and the specification tags / plates attached to each component. Contact Spirax Sarco or your authorised sales representative, before proceeding with the installation if any non-conformances are found.

3.7 Mounting the unit

The unit should be mounted to the floor using the four individual foot mounts supplied as standard, following applicable local code requirements, or accepted standards for the specific installation site and for the unit purchased. In areas prone to seismic activity, it is recommended that the unit be mounted to the floor, according to recommended procedures for the site, to make the unit less susceptible to seismic damage.

3.8 Installation - Preliminary procedures

Install the CSM-E electrical compact clean steam generator by following this simple procedure:

1. Connect the feedwater supply to the feedwater inlet - Section 3.9
2. Connect the generated clean steam outlet to the clean steam supply - Section 3.9
3. Connect the safety valve and discharge to a safe area - Section 3.10
4. Connect the appropriate instrument (control) air supply - Section 3.11
5. Connect the drain / bottom blowdown connection to the correct system pipework -Section 3.12
6. Connect the system sampling points - Section 3.13
7. Connect the electrical connections and power supply - Section 3.14



The drawings used in this manual are examples only and show standard connections. For connection locations and specifications (type and size) of the ordered unit always refer to the drawings supplied with the unit.

3.9 Connecting the feedwater supply and generated clean steam outlet



Note: Before connecting to feedwater inlet or generated clean steam outlet on the unit, ensure that all pipework is clean and free of foreign material or scale. This can usually be accomplished by 'blowing out' the pipe. Any foreign material or scale entering the unit can adversely affect operation and performance.

3.9.1 Feedwater supply

The first step in the installation process is to connect the feedwater supply to the feedwater inlet connection - see Figure 4.

A manual shut-off valve should be installed upstream on the feedwater supply as an isolation device. The shut-off valve should be in the closed position and remain so until the installation is complete.



Note: All pipework connections for clean steam and water should be flanged or sanitary type in design, the type of gasket material should be suitable for clean steam application.

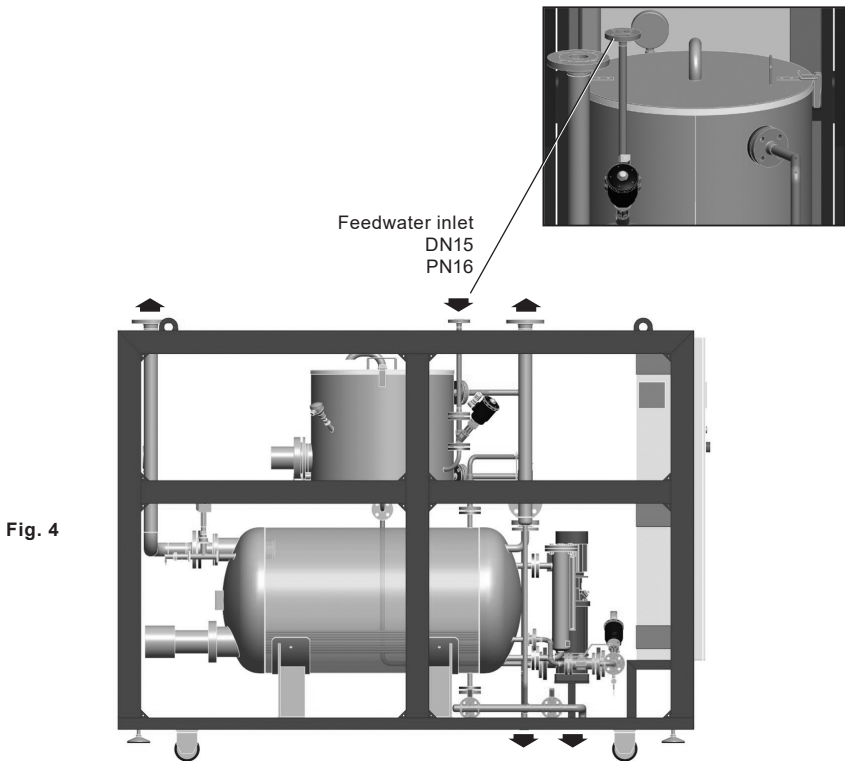

Fig. 4

3.9.2 Generated clean steam outlet

The next step in the installation process is to connect the generated steam system pipework to the clean steam outlet connection (Figure 5). A manual shut-off valve should be installed downstream on the generated clean steam line for isolation purposes in case the unit is disconnected from the system. The shut-off valve should be in the closed position and remain so until the installation is complete.

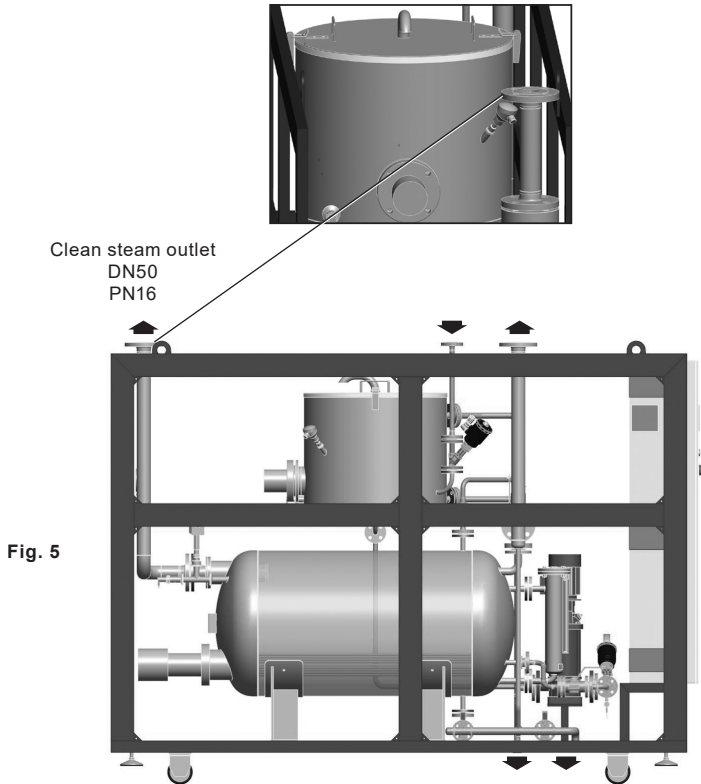

Fig. 5



Note: Refer to local regulations and specifications for site specific shut-off and check valve requirements.

Note: All pipework connections for clean steam and water should be flanged or sanitary type in design, the type of gasket material should be suitable for clean steam application.

3.10 Piping the safety valve to vent and drain

All Spirax Sarco CSM-E compact clean steam generators are equipped with a pressure safety valve. In most applications, the pressure safety valve should be vented to atmosphere (generally through the roof). The piping used in the vent system **must be of adequate size to handle the capacity of the pressure safety valve**. The vent piping system should allow for condensate drainage and should be piped to a suitable drain (Figure 6). Piping the pressure safety valve to a suitable vent and drain will prevent both water and heat damage to the unit, as well as reduce the risk of injury from released steam. All safety discharge pipework should comply with local codes. It is the responsibility of the purchaser / installing contractor to ensure this compliance.

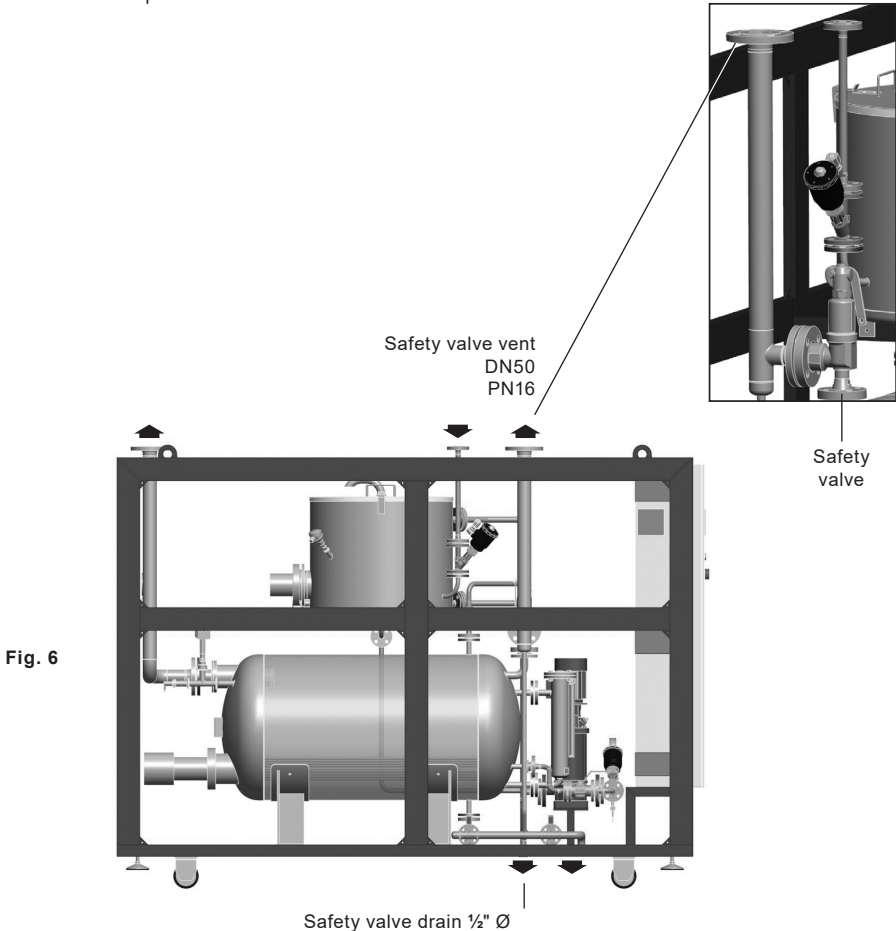

Installation should be done according to local standards.

3.11 Connecting electro-pneumatically activated controls

Spirax Sarco CSM-E compact clean steam generators are equipped with pneumatically activated controls. In most cases where pneumatically activated controls are used, they require an instrument air pressure supply of 6 bar g, 90 psi g (Figure 7). Refer to the supplied drawing, and specific installation and operation instructions for each component to determine the requirements for that particular component.

Compressed air using
tube diameter of 8 mm

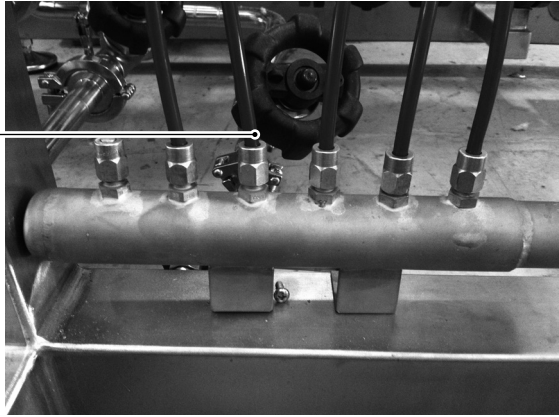

Fig. 7



Ensure that the pneumatic feedline has been shut down, and air pressure bled from the system by acceptable methods, before attempting any connections.

Reference the drawings that are included, or the installation instructions contained in the Installation Manual for the component, for specific piping instructions.



Note: For all pneumatic connections, the use and/or type of joint compound or sealer on the joint should be determined by referring to local codes, accepted practices, or the requirements of the installing contractor.

3.12 Connecting the drain / bottom blowdown line

Spirax-Sarco CSM-E compact clean steam generators are equipped with a drain / bottom blowdown line. Each generator has a manual blowdown valve fitted as standard which is connected to the bottom of the vessel (Figure 8). The blowdown from this valve is at the pressure and temperature of the generated steam and can cause severe injury or death if not properly piped.

In accordance with local regulations or standards, it is recommended that the blowdown lines be connected to a blowdown vessel or condensate cooler before being discharged to drain.

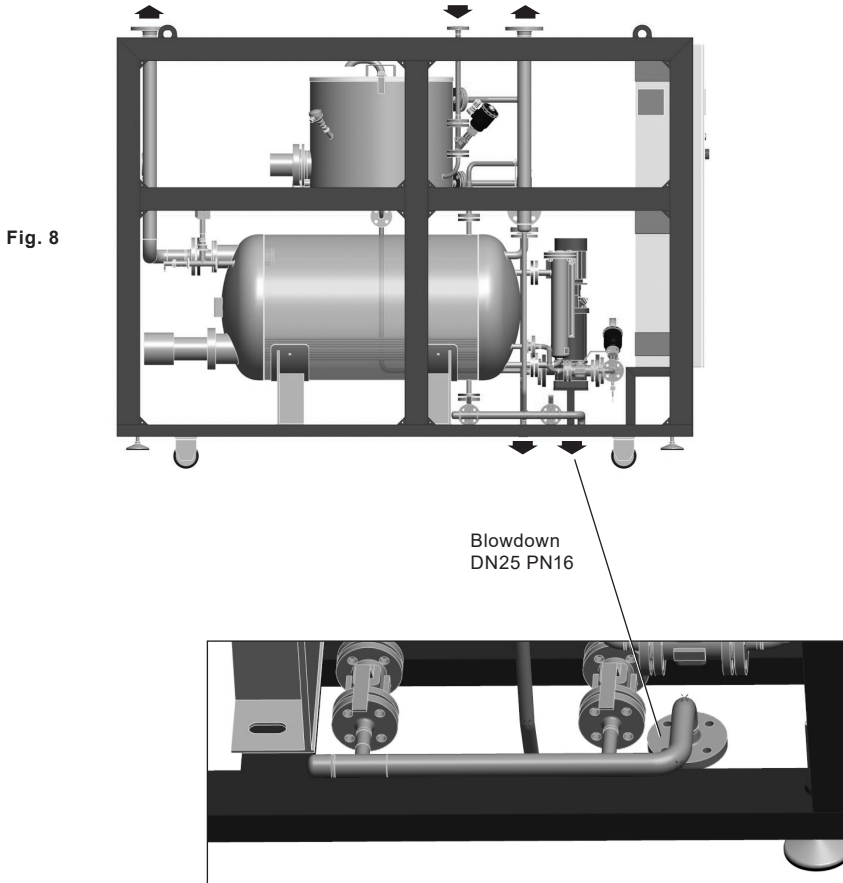

Note: Blowdown connection should be performed in accordance to local codes, accepted practices, or the requirements of the installing contractor.

3.13 System sampling points

Spirax Sarco recommends the installation of sample points throughout the system. HTM 2031 specifies that throughout the process of clean steam generation, system sampling should be facilitated, as a minimum, at the following points:

- Mains water.
- Treated water (sample points between stages).
- Feedwater / boiler water.
- Steam generator water.
- Steam at point of use.

These points will allow for easy sampling and testing of the system. For further information contact Spirax Sarco.

3.14 Electrical connections and power supply



Attention: the user is responsible for electrical connections to the package.



Attention: do not route signal and control wiring with power wiring in the same conduit. This can cause interference with operation. Failure to observe this precaution could result in damage to, or destruction of, the unit.



Attention: a power disconnect device must be installed by the user, between the general power line and the cabinet. If the power disconnecting device is a circuit breaker, the circuit breaker must be able to trip 25 Amperes. It is important to verify that the main power will meet input power requirements of the control cabinet. Be sure that input power corresponds to the name-plate voltage and frequency.



Attention: unused wires in conduit must be grounded at both ends to avoid a possible shock hazard caused by induced voltages.

3.14.1 Grounding the cabinet



Attention: the user is responsible for conforming to all the applicable local, national and international codes. Failure to observe this precaution could result in damage to, or destruction of the equipment.

Use the following steps to ground:

Step 1: Open the cabinet door.

Step 2: Run a ground unbroken conductor from the control cabinet ground terminal PE to the earth ground. Ground cable must be not less than 120 mmq.

3.14.2 Connecting the primary supply (electric heating coils)



Possible injury or death.

The electric heating coils are connected directly to the control board (control cabinet) - see Figure 9.

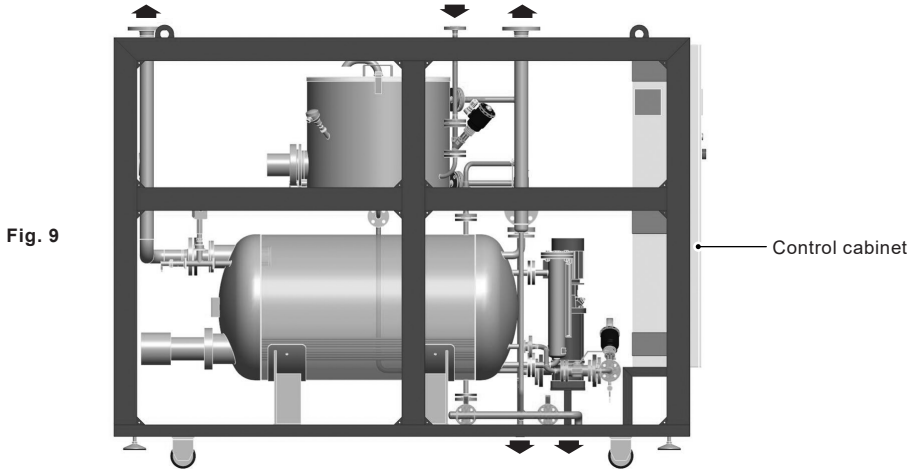

Fig. 9

3.14.3 Installed load of the unit:

Units are normally wired for a three-phase input voltage of 400 Vac + Neutral 50 Hz.

GENERATOR WITHOUT PRE-HEAT TANK			
Unit	CSM-EE	CSM-EG	CSM-EI
Installed load	55 kW	105 kW	115 kW

GENERATOR WITH PRE-HEAT TANK			
Unit	CSM-EF	CSM-EH	CSM-EL
Installed load	55 kW	120 kW	130 kW

Note: Always refer to wiring diagram.

3.14.4 Mains power supply

Display: 5.7" Touch-screen with high resolution colour graphics.

Input voltage: 400 Vac 3 pH + Neutral - 50 Hz (**always refer to wiring diagram**).

Input contacts: 3 A – 230 V for inductive loads.

Output contacts: 6 A – 230 V for resistive loads.

Operational ambient temperature: Minimum 0°C to a Maximum 50°C (inside the control cabinet)*.

Relative Humidity (RH): from 5% to 95% non-condensing.

*Note: If the environmental conditions raise the temperature inside the cabinet to over 50°C, conditioning devices are available on request. Please contact your nearest Spirax Sarco branch or agency for further details.

3.14.5 Installing power input lines

Use the following steps to connect an AC input power supply to the control cabinet:

Step 1: Wire the AC input power leads by routing them in the cabinet unit through the plug.

Step 2: Connect the 3 phase AC + Neutral input power leads to terminals **R, S, T** and **N** input on the Terminal board.

Step 3: Tighten the AC input terminals.

Installation completion - Installation of the CSM-E compact clean steam generator is only complete when all of the Sections within 3 have been actioned and checked by a safety officer.

4. Commissioning

After all installation procedures have been completed within Section 3, and all clean steam, feedwater, heating coil(s), pneumatic joints, and power connections have been double checked by a safety officer, the unit is ready for commissioning.

4.1 Commissioning procedure

Commissioning may now be carried out in accordance with the following procedure.

Please note: It is recommended that this procedure is always carried out in the presence of a qualified Spirax Sarco engineer.

Installation inspection:

1. Ensure that the unit has been installed in line with Spirax Sarco recommendations as specified in Section 3.
2. Ensure that the blowdown and safety valve lines are piped away to a safe location.
3. Ensure that all manual isolation valves have been closed: Clean steam outlet, Feedwater inlet and pneumatic supply.

Pre-commissioning inspection:

4. Check that all flanged connections within the generator are tight.
5. Note orientation of the feedtank level transducer (**should be horizontal**).
6. Check the electrical connections.
7. Check that the supply voltage is correct.
8. Check that the pneumatic supply is correct.

4.2 Start-up operating procedure

4.2.1 Cold start-up

The following procedure must be followed when bringing the clean steam generator into operation from an isolated and empty condition:

1. Ensure that all manual isolation valves are in a fully closed position.
2. Turn on the electrical power supply.
3. Turn on the compressed air supply.
4. Open the manual isolation valve for the treated feedwater supply.
5. Press the tank **START** key on the control panel touch screen.
6. The low water level alarm may activate, if so press the manual reset button on the front of the control panel.
7. Observe the rise in the displayed water level on the control panel tank synoptic screen.
8. Check that the tank stops filling when the set point level is reached.
9. Press the generator **START** key on the control panel touch screen.
10. Observe the rise in the displayed water level on the control panel generator synoptic screen.
11. Check that the generator stops filling when the set point level is reached.
12. Observe that the tank reaches the programmed set point temperature on the synoptic screen.
13. Observe that the generator reaches the programmed set point pressure on the synoptic screen.
14. Leave the generator in operation for sufficient time to allow any non-condensable gases to dissipate.
15. Slowly open the clean steam outlet manual isolation valve.
16. The unit is now ready for operation.

Note: For further information on procedure steps 5, 6, 7, 8, 9, 10, 11, 12 and 13, please refer to the PLC Control Unit Manual IM-P486-18. Procedure steps 5, 6, 7, 8 and 12 will not apply if the tank is not fitted.

4.2.2 Cycle interrupted

The following procedure must be followed when bringing the generator back on line following an alarm condition lockout or temporary shutdown:

1. Check that the feedtank water level is at maximum and that the temperature is above 65°C via the tank synoptic screen (if present). If this is not the case then the cold start-up procedure must be followed - Section 4.2.1.
2. Check that the generator pressure is above 0.1 bar g via the generator synoptic screen. If this is not the case then the cold start-up procedure must be followed - Section 4.2.1.
3. Check that the 'Emergency Stop' button on the front of the control panel has been released. Also check that all remote stops have been released.
4. Press the manual reset button on the front of the control panel.
5. Check that all manual isolation valves are in an open position.
6. Press the **MAIN START** key on the control panel touch screen.
7. The generator will come back on line and the clean steam outlet valve will open when the programmed operating pressure set point is reached (if present).
8. Check that the heating coil(s) are connected on the control panel touch screen.

Note: For further information on procedure steps 1, 2, 3, 4, 6 and 8, please refer to the PLC Control Unit Manual IM-P486-18. Procedure step 1 will not apply if the tank is not fitted.

4.3 General operating procedure

4.3.1 Configuration parameters

For further information, please refer to the PLC Control Unit Manual IM-P486-18 Section 4.2 'Protected parameters'.

4.3.2 Manual Operation

For further information, please refer to the PLC Control Unit Manual IM-P486-18 Section 4.3 'Manual cycle'.

Note: During the manual cycle check that the feedwater pump is rotating in the correct direction and that there are no signs of cavitation in the pump. If pump direction is incorrect, turn off the electrical power supply and reverse two of the three phase electrical supply to the pump. If there is evidence of pump cavitation, it must be purged. Please refer to the maintenance instructions in Section 5 of this manual before attempting any removal or inspection of the pump unit.

4.3.3 Automatic Operation

For further information, please refer to the PLC Control Unit Manual IM-P486-18 Section 4.3 'Automatic cycle'.

4.4 Shutdown operating procedure

The following procedure must be followed when shutting down the unit for extended periods such as over weekend or for maintenance purposes:

1. Close the manual isolation valve for the treated feedwater supply.
2. Allow the generator pressure to fall to the point where the clean steam outlet valve closes (if present).
3. Close the clean steam outlet manual isolation valve.
4. Press the **MAIN STOP** key on the control panel touch screen.
5. Open the manual drain valve and leave it open until the feedtank (if present) and/or generator vessel are empty (depending on the location of the equipment or component to be maintained).
6. Close all other manual isolation valves and lock off.
7. Turn off the electrical power supply.

4.5 Emergency shutdown procedure

The following procedure must be followed in the event that an emergency shutdown is required.

The emergency shutdown procedure must only be used in the event of an unusual occurrence that requires the rapid isolation of the clean steam supply or in the unlikely event of a malfunction within the clean steam generator.

1. Press the 'Emergency Stop' button either on the front of the control panel or at the remote location.
2. Close the clean steam outlet manual isolation valve.
3. Close all other manual isolation valves and lock-off.

4.6 Daily maintenance

The clean steam pressure should be checked at the pressure gauge **at least twice a day**.

The unit has been equipped with a feedwater make-up system which is automated and maintenance need not be carried out by operating personnel.

4.7 Bottom blowdown

Spirax Sarco CSM-E compact clean steam generators are equipped with a drain and bottom blowdown line. Blowdown is controlled using either a manual isolation valve (fitted as standard) or an automatic blowdown valve (optional) which is connected to the bottom of the generator vessel. The automatic blowdown valve can be programmed through a timer in the PLC control unit to set/adjust the frequency and duration of discharged steam.



The blowdown from this valve is at the pressure and temperature of the generated steam and can cause severe injury or death if not properly piped. It is recommended that the blowdown lines be connected to a blowdown vessel before being discharged to drain.



The blowdown from the CSM-E compact clean steam generator can flash to steam when introduced to atmospheric pressure.

Spirax Sarco recommends the use of automatic blowdown valves with its generators. The build-up of scale and dirt within the unit can effect operation and the quality of the clean steam and shorten the life of the unit.

The unit should be blown down a minimum of once a day.

The frequency of necessary blowdown is directly affected by the minerals, chemicals, and contaminants contained in the feedwater.

Depending on the water quality, the blowdown interval may need to be altered (either more or less frequently) for each site.

4.7.1 Water quality

Feedwater pipework - The feedwater in the feedtank (if present) is recirculated to minimise stagnant water within the system, and to assist in the removal of non-condensable gases. Water within the feedtank should be maintained above 80°C. HTM 2031 gives specifications for contaminants within the steam condensate, as identified in the table below:

Property	Unit	Maximum permitted values HTM 2031 clean steam condensate
Acidity or Alkalinity	-	NQ
Degree of Acidity	pH	6 - 8
Ammonium, NH ₄ ⁺	mg/lit	≤ 0.2
Calcium and Magnesium	mg/lit	NQ
Total hardness, CaCO ₃	mg/lit	< 2
Heavy metals	mg/lit	≤ 0.1
Iron, Fe	mg/lit	< 0.1
Cadmium, Cd	mg/lit	< 0.005
Lead, Pb	mg/lit	< 0.05

Property	Unit	Maximum permitted values HTM 2031 clean steam condensate
Chloride, Cl	mg/lit	0.5
Nitrate, NO ₃ ⁻	mg/lit	0.2
Sulphate, SO ₄ ²⁻	mg/lit	NQ
Oxidising substances	-	NQ
Residue on evaporation	mg/lit	30
Silicate, SiO ₂	mg/lit	< 0.1
Phosphate P ₂ O ₅	mg/lit	< 0.1
Conductivity at 25°C	µS/cm	35
Bacterial endotoxins	EU/ml	0.25
Appearance		Clear, colourless

4.8 Feedwater

CSM-E compact clean steam generators are equipped with a PLC level controller which will activate the feedwater control valve and complement the feedwater recirculation pump, the pump is maintained at constant speed, to maintain the correct water level in the generator. The PLC level controller will send a signal to the control valve to feed water to the generator when the level falls under the setpoint level and stop feeding when the water level reaches the set point. The level controller also has a low water alarm position which will activate if the water falls below the predetermined alarm, set on the PLC. There are also two level limits installed in the same level sensor (Figure 10) that are calibrated for low and high levels. If a low level condition occurs, the heating coil(s) are disconnected, an alarm will be activated and the generator will shut down.



Note: As the feedwater level is being raised, pressure may be released from the pressure safety valve to the atmosphere.

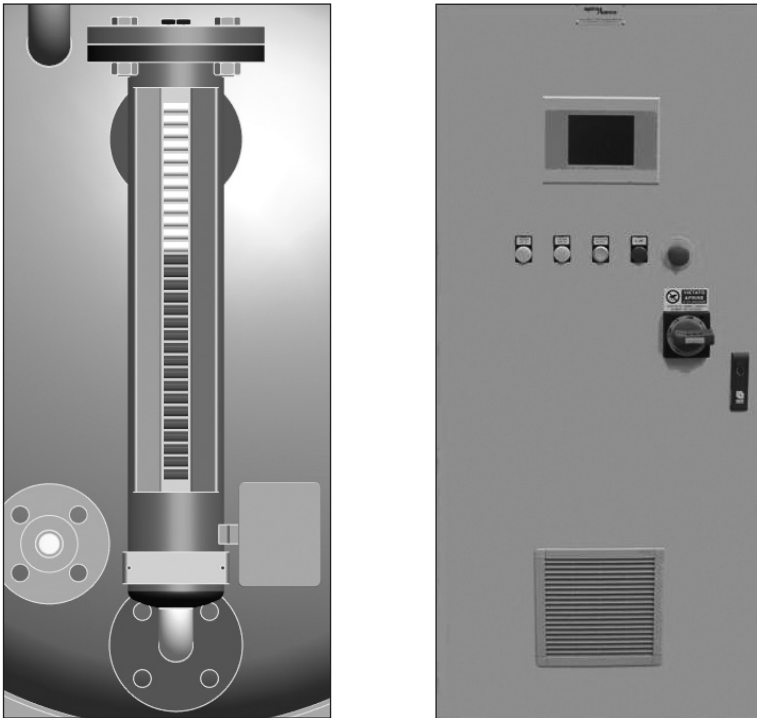

Fig. 10

4.9 Water temperature in pre-heating/degassing tank (if present)

The pre-heating tank water temperature is controlled by a temperature probe (fitted with transmitter) which is installed through the side of the tank below the minimum water level (Figure 11). The temperature probe sends a 0 - 10 V signal (equivalent to 0 - 100°C range) to the PLC control unit where it is processed and used to regulate (modulating control) the power supply to the heating coil and thus maintain a constant temperature in the tank.

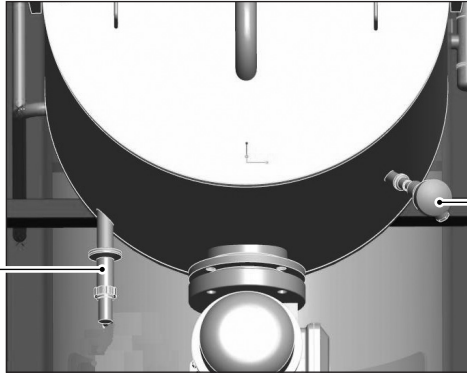

Fig. 11

Level transmitter
(pre-heating tank)

Probe and temperature
transmitter
(pre-heating tank)

4.10 Water level in pre-heating/degassing tank (if present)

The pre-heating tank water level is controlled by a level transmitter (differential pressure) which is installed in the bottom of the tank (Figure 11). The level transmitter sends a 0 - 10 V signal (equivalent to 0 - 100 mbar g range) to the PLC control unit where it is processed and used to regulate the ON - OFF control signal to the feedwater inlet piston control valve and thus maintain a constant water level in the tank.

4.11 Clean steam pressure

Clean steam pressure is controlled by a pressure transmitter which is installed on the head of the generator vessel (Figure 12). The pressure transmitter sends a 0 - 10 V signal (equivalent to 0 - 6 bar g range) to the PLC control unit where it is processed and used to adjust the control signal to the heating coil(s) and thus maintain a constant clean steam supply pressure.

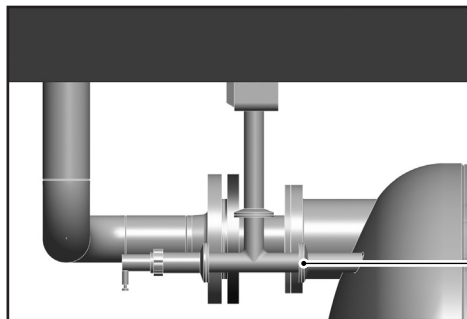

Fig. 12

Pressure transmitter
(clean steam)

5. Maintenance

See Section 5.5 for a recommended maintenance schedule.

5.1 General information

The information contained in this Section will detail service and maintenance procedures for the inspection and replacement of components used in the manufacture of the Spirax Sarco CSM-E compact clean steam generator range. Please note that this manual may be general in some instances. If there are any questions concerning maintenance procedures that are not clearly explained in this manual, contact Spirax Sarco.

Please note: Be sure to have the model and serial numbers of the unit and heating coil(s) available before making contact.



Note: Many of the maintenance procedures detailed in this Section will require the unit to be taken off-line before the procedure is performed; and put back online after the procedure is completed. It is recommended that the maintenance personnel performing these procedures review the start-up and shutdown procedures, detailed in Sections 4.2 and 4.4, before attempting any maintenance procedure.

Any component(s) directly connected or linked to the component being replaced should carefully be examined before maintenance procedures are started. If any of the related components show signs of wear or improper operation, they should be considered for replacement at the same time.

5.2 Power connections - Rewiring

If any power connections to electrically activated controls or junction boxes require rewiring, follow the steps listed below.



The combination of electricity, steam, and water can pose a very dangerous situation. Turn off/disconnect all electric power before attempting any maintenance procedure.

1. Follow the shutdown procedure (Section 4.4) to take the unit off-line before attempting any electrical service.
2. After ensuring that the power has been turned off, disconnect and rewire the electrical connections in question.
3. Turn the power on and check that the component that has been rewired is functioning properly.
4. Follow the start-up procedure in Section 4.2 of this manual to return the unit to operation.

5.3 Pneumatic (instrument air) connections - Refitting

If any pneumatic (instrument air) connections to pneumatically activated controls require refitting, follow the steps listed below.



Instrument air, at a pressure of 6 bar g (90 psi g) is, in most cases, required to activate pneumatic controls. Air pressure at this level can pose a very dangerous situation. Ensure that the air source has been shut down and that the line pressure has been relieved before breaking any pneumatic connection.

1. Follow the shutdown procedure (Section 4.4) to take the unit off-line before attempting any pneumatic service.
2. After ensuring that the air supply has been turned off, break and rework the pneumatic connections in question.
3. Turn the air supply on and check that the component that has been reconnected is functioning properly.
4. Follow the start-up procedure in Section 4.2 of this manual to return the unit to operation.

5.4 Equipment and Components - Inspection and/ or Replacement

5.4.1 Heating coils (electric elements)

The heating coils are fundamental to the successful operation of the CSM-E compact clean steam generator. Dependant upon insurance requirements they should be removed and inspected at least every two (2) years. There is a gasket for each heating coil.

Note: The procedure outlined below refers to the generator vessel heating coil(s) but it is also applicable to the feedtank heating coil (if fitted).



The clean steam system can be very dangerous because of the high temperatures and pressures. To avoid possible injury or death, follow all accepted and recommended procedures when performing installation, operation, and maintenance procedures.



The combination of electricity, steam, and water can pose a very dangerous situation. Turn off / disconnect all electric power before attempting any maintenance procedures.

1. Follow the shutdown procedure (Section 4.4) to take the unit off-line before attempting to remove and inspect the heating coil.
2. Ensure that the pressure has been relieved from the clean steam system and that all components and surfaces have cooled.
3. Remove the bolts and nuts from the mounting flange securing the heating coil header to the vessel.
4. Carefully separate the heating coil header from the mounting flange and withdraw the coil assembly from the vessel.



There may still be residual steam condensate (or boiler/high temperature water), this residual condensate/water could present a danger of injury. Allow sufficient time for cooling before removing the heating coil from the vessel.

5. Examine the heating coil for scale buildup and signs of damage. If no damage is detected, carefully clean the excess scale from the coil and prepare for installation. If damage is detected, replace the complete coil assembly.
6. Remove the old gasket and thoroughly clean the mating surfaces. Install the new gasket.
7. Carefully insert the heating coil assembly into the vessel.
8. After ensuring that the heating coil assembly is correctly installed, clamp the flanges together and continue with the torque procedure detailed in Section 6.
 - a. Lubricate the bolt threads and the nut faces with a suitable lubricant.
 - b. Insert the bolts through the flanges, then finger tighten the nuts to the bolts.
 - c. Number all the bolts so that torquing requirements can be followed.
 - d. Apply torque to each bolt in twenty percent (20% [1 / 5]) increments of the required total torque, loading all bolts at each incremental stage before proceeding to the next increment.
 - e. Use rotational tightening until all bolts are secure at the final torque level. A minimum of two (2) rotations is usually required.
9. Reconnect the heating coil at the ECB (electronic control board).
10. Follow the start-up procedure (Section 4.2) to put the unit back on-line.
11. **Carefully check all connections for any sign of leakage.**

5.4.2 Inlet and outlet lines and manual shut-off valves

If the feedwater inlet or clean steam outlet lines or shut-off valves are damaged and must be replaced, follow the procedure outlined below.



The combination of electricity, steam, and water can pose a very dangerous situation. Turn off/disconnect all electric power before attempting any maintenance procedures.

1. Follow the shutdown procedure (Section 4.4) to take the unit off-line before attempting to replace damaged lines or shut-off valves.



While it might seem feasible to replace inlet and outlet lines and shut-off valves without shutting down the entire unit, it is not advised.

Unless the unit is completely shutdown, and the clean steam is isolated from the system, failure of a manual shut-off valve during the replacement process could result in serious injury.

2. Ensure that the pressure has been relieved from the clean steam system and that all components and surfaces have cooled.
3. Carefully break the joint between the unit and the line or valve to be replaced.
4. Remove the section of line or valve to be replaced.
5. Replace the damaged section of line or valve.
6. Reconnect the line or valve to the unit. Follow recommendations contained in the manufacturer's documentation, local codes, or accepted contractor practices as to the use and /or type of joint compound or sealer at the connections.
7. Follow the start-up procedure (Section 4.2) to put the unit back on-line.
8. **Carefully check all connections for any sign of leakage.**

5.4.3 Pressure safety switch - Figure 13



The clean steam system can be very dangerous because of the high temperatures and pressures. To avoid possible injury or death, follow all accepted and recommended procedures when performing installation, operation, and maintenance procedures.



The combination of electricity, steam, and water can pose a very dangerous situation. Turn off/disconnect all electric power before attempting any maintenance procedures.

The safety pressure switch acts as a fail-safe for Spirax Sarco compact clean steam generators. The alarm and shut down for high pressure is set at a value lower than that which has been set for the safety valve. It requires power to operate, therefore in the case of a power failure, the unit will totally shut down. If it is mandatory that the unit remain in operation during power failures, it should be wired into the emergency power system. If the pressure safety switch is not functioning correctly and must be replaced, follow the procedure outlined below.

1. Follow the shutdown procedure (Section 4.4) to take the unit off-line before attempting to replace the safety pressure switch.
2. Ensure that the pressure has been relieved from the clean steam system and that all components and surfaces have cooled.
3. Carefully disconnect the wires leading from / to the control cabinet.
4. Loosen the connections until the pressure probe can be removed.
5. Examine the probe for damage or incorrect positioning. For the exact procedure for examination refer to the Spirax Sarco product specific Installation and Maintenance manual supplied with the unit.
6. To install a new unit follow the recommendations contained in the manufacturer's documentation.
7. After ensuring that the unit is correctly installed, tighten the fittings and sanitary connections using new sanitary type gaskets where required.
8. Follow the start-up procedure (Section 4.2) to put the unit back on-line.
9. **Carefully check all connections for any sign of leakage.**

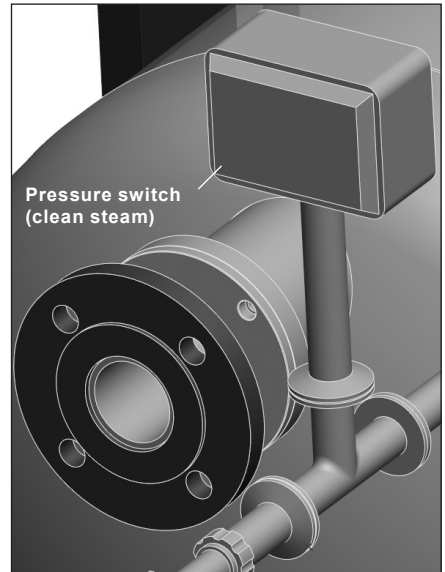

Fig. 13

5.4.4 Steam pressure transmitter - Figure 14



The clean steam system can be very dangerous because of the high temperatures and pressures. To avoid possible injury or death, follow all accepted and recommended procedures when performing installation, operation, and maintenance procedures.



The combination of electricity, steam, and water can pose a very dangerous situation. Turn off / disconnect all electric power before attempting any maintenance procedures.

The steam pressure transmitter monitors and controls outlet clean steam pressure by sending a signal to the PLC control unit which is used to adjust power supply to the heating coil.

It requires power to operate, therefore in the case of a power failure, the unit will totally shut down. If it is mandatory that the unit remains in operation during power failures, it should be wired into the emergency power system.

If the pressure transmitter is not functioning correctly and must be replaced, follow the procedure outlined below.

1. Follow the shutdown procedure (Section 4.4) to take the unit off-line before attempting to replace the steam pressure transmitter.
2. Ensure that the pressure has been relieved from the clean steam system and that all components and surfaces have cooled.
3. Carefully disconnect the wires leading from / to the control cabinet.
4. Loosen the connections until the transmitter can be removed. Examine the probe for damage or incorrect positioning. For the exact procedure for examination refer to the Spirax Sarco product specific Installation and Maintenance manual supplied with the unit.
5. To install a new unit follow the recommendations contained in the manufacturer's documentation.
6. After ensuring that the unit is correctly installed, tighten the fittings and sanitary connections using new sanitary type gaskets where required.
7. Follow the start-up procedure (Section 4.2) to put the unit back on-line.
8. **Carefully check all connections for any sign of leakage.**

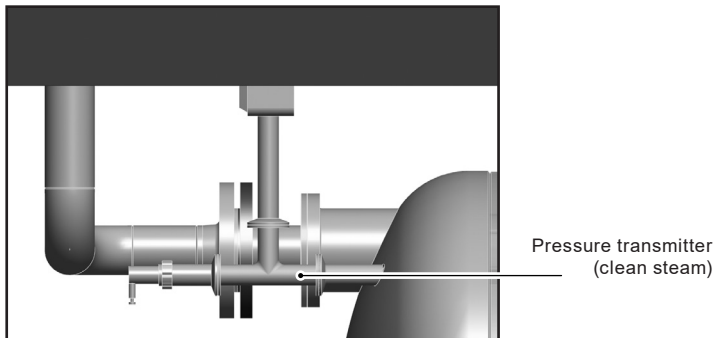

Fig. 14

5.4.5 Pressure safety valve (generator) - Figure 15

The pressure safety valve acts as a fail-safe for Spirax Sarco compact clean steam generators. The valve will open for high pressure to protect the system from explosion.

If the pressure safety valve is not functioning correctly and must be replaced, follow the procedure outlined below.



The combination of electricity, steam, and water can pose a very dangerous situation. Turn off/disconnect all electric power before attempting any maintenance procedures.

1. Follow the shutdown procedure (Section 4.4) to take the unit off-line before attempting to replace the pressure safety valve.
2. After ensuring that the pressure has been relieved from the clean steam system and that all components and surfaces have cooled, disconnect the vent line leading from the pressure safety valve to atmosphere (usually through the roof), and via a drip elbow, to drain.
3. Carefully disconnect the pressure safety valve from between the generator vessel and the feedtank.
4. Install the new valve following the recommendations contained in the manufacturer's documentation, local codes, or accepted contractor practices as to the use of joint compound or sealer at the connections.
5. Reconnect the vent line leading from the pressure safety valve to atmosphere and, via drip elbow, to drain.
6. Follow the start-up procedure (Section 4.2) to put the unit back on-line.
7. **Carefully check all connections for any sign of leakage.**

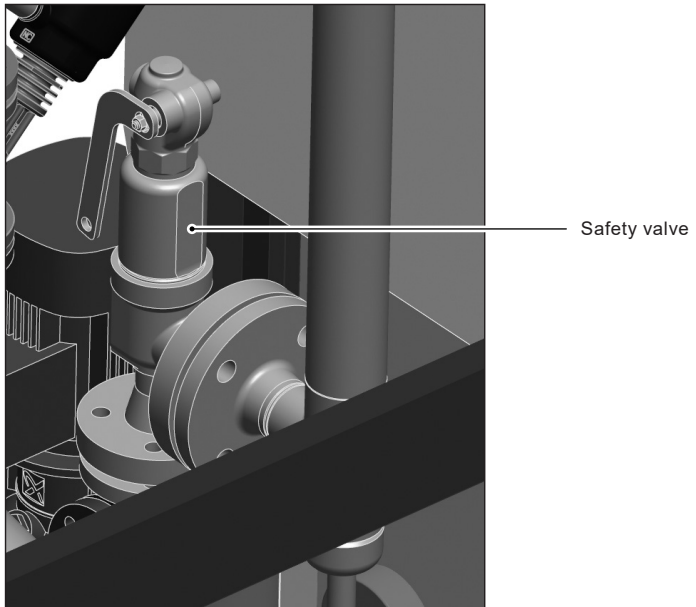

Fig. 15

5.4.6 Pressure gauge (clean steam/feedwater) - Figure 16

If the feedwater inlet or clean steam outlet pressure gauges are not functioning correctly and must be replaced, follow the procedure outlined below.



The combination of electricity, steam, and water can pose a very dangerous situation. Turn off / disconnect all electric power before attempting any maintenance procedures.

1. Follow the shutdown procedure (Section 4.4) to take the unit off-line before attempting to replace the pressure gauge.
2. Carefully close the pressure gauge isolation valve.
3. Remove the gauge from its mounting and replace with the new gauge (sanitary type).
4. Open the pressure gauge isolation valve. Follow the recommendations contained in the manufacturer's documentation, local codes, or accepted contractor practices as to the use and/or type of joint compound or sealer at the connections.
5. Follow the start-up procedure (Section 4.2) to put the unit back on-line.
6. **Carefully check all connections for any sign of leakage.**

Clean steam pressure gauge



Feedwater pressure gauge

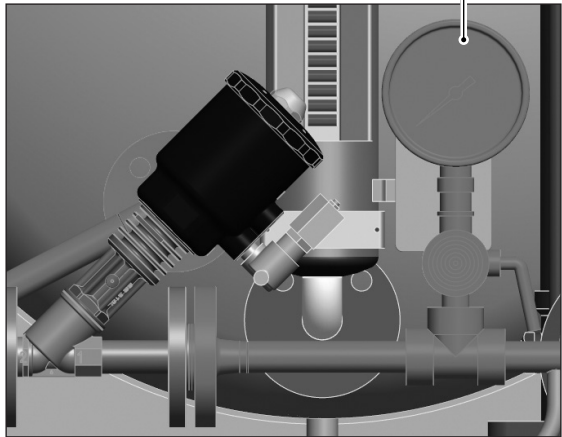

Fig. 16

5.4.7 Level controller - Figure 17

The level controller supplied on the CSM-E compact clean steam generator controls the level of the water within the unit, ensuring that the unit will function safely and effectively. If the level controller must be removed for inspection, adjustment, or replacement, follow the procedure outlined below.



The clean steam system can be very dangerous because of the high temperatures and pressures. To avoid possible injury or death, follow all accepted and recommended procedures when performing installation, operation, and maintenance procedures.



The combination of electricity, steam, and water can pose a very dangerous situation. Turn off / disconnect all electric power before attempting any maintenance procedures.

1. Follow the shutdown procedure (Section 4.4) to take the unit off-line before attempting to remove and inspect the level controller.
2. Ensure that the pressure has been relieved from the clean steam system and that all components and surfaces have cooled.
3. If the level controller is not completely drained and bled, steam or boiling water may be discharged.
4. Disconnect the wires leading from the control cabinet.
5. Disconnect the level controller from the vessel.
6. Continue to loosen the connections until the level controller can be removed.
7. Examine the level probes/gauge for damage or incorrect positioning. For the exact procedure for examination refer to the Spirax Sarco product specific Installation and Maintenance manual supplied with the unit.
8. To reinstall the level controller, align with the feedlines and start refitting following the recommendations contained in the supplied documentation.
9. After ensuring that the level controller is correctly aligned, tighten the fittings.
10. Follow the start-up procedure (Section 4.2) to put the unit back on-line.
11. **Carefully check all connections for any sign of leakage.**

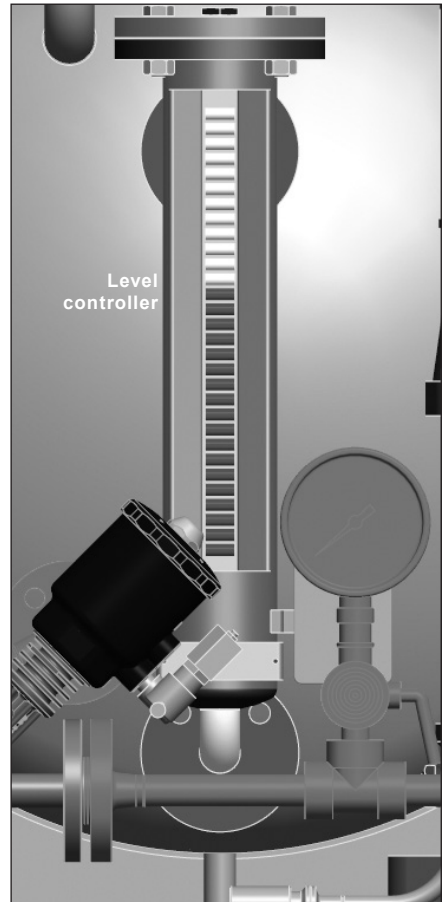

Fig. 17

5.4.8 Feedwater pump - Figure 18

The feedwater pump is supplied on the CSM-E compact clean steam generator to supply the required pressure to the feedwater to fill the generator, ensuring that the unit will function safely and effectively. If the pump must be removed for inspection, adjustment, or replacement, follow the procedure outlined below.



The clean steam system can be very dangerous because of the high temperatures and pressures. To avoid possible injury or death, follow all accepted and recommended procedures when performing installation, operation, and maintenance procedures.



The combination of electricity, steam, and water can pose a very dangerous situation. Turn off / disconnect all electric power before attempting any maintenance procedures.

1. Follow the shutdown procedure (Section 4.4) to take the unit off-line before attempting to remove and inspect the feedwater pump.
2. Ensure that the pressure has been relieved from the clean steam system and that all components and surfaces have cooled.
3. If the pump is not completely drained, hot water may be discharged.
4. Disconnect the wires leading from / to the control cabinet.
5. Disconnect the pump from the adjoining pipework.
6. Continue loosening the connections until the pump can be removed.
7. Examine the pump for damage or incorrect positioning. For the exact procedure for examination refer to the Spirax Sarco product specific Installation and Maintenance manual supplied with the unit.
8. To install a new pump, align with the feedlines and start refitting following the recommendations contained in the supplied documentation.
9. After ensuring that the pump is correctly aligned, tighten the fittings.
10. Follow the start-up procedure (Section 4.2) to put the unit back on-line.
11. **Carefully check all connections for any sign of leakage.**

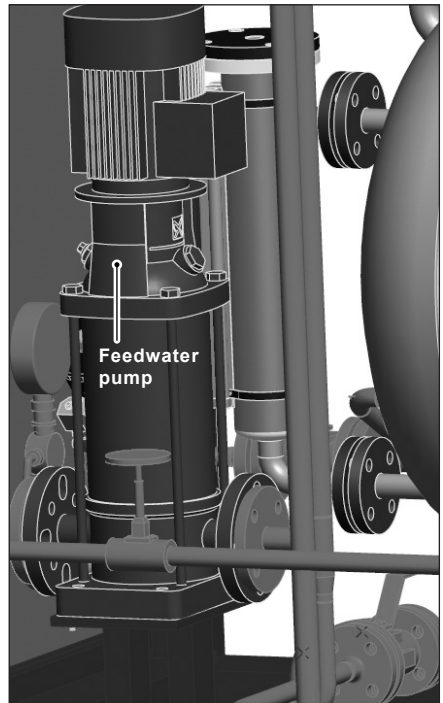

Fig. 18

5.4.9 Piston valves - Figure 19

The product specific documentation included with the unit provides the relevant operation and maintenance instructions for all piston valves - tank feedwater inlet (if fitted), generator feedwater inlet, bottom blowdown (if fitted) and clean steam outlet (if fitted). The drawing included with the unit will give the exact location, as well as connection with other components. This information should be reviewed before removal / replacement of any valves.



The clean steam system can be very dangerous because of the high temperatures and pressures. To avoid possible injury or death, follow all accepted and recommended procedures when performing installation, operation, and maintenance procedures.



The combination of electricity, steam, and water can pose a very dangerous situation. Turn off / disconnect all electric power before attempting any maintenance procedures.

1. Follow the shutdown procedure (Section 4.4) to take the unit off-line before attempting to remove and inspect the piston valve.
2. Ensure that the pressure has been relieved from the clean steam system and that all components and surfaces have cooled.
3. If the unit is not completely drained and bled, steam or boiling water may be discharged.
4. Disconnect the wires leading from / to the control cabinet, turn off the instrument air source, bleed the pressure from the line, and disconnect the lines to the valve.
5. Disconnect at the joint.
6. Continue to loosen the connections until the valve can be removed.
7. Examine the valve for damage or incorrect positioning. For the exact procedure for examination refer to the Spirax Sarco product specific Installation and Maintenance manual supplied with the unit.
8. To install a new valve, align with the feedlines and start refitting following the recommendations contained in the relevant supplied documentation.
9. After ensuring that the valve is correctly aligned, tighten the fittings.
10. Follow the start-up procedure (Section 4.2) to put the unit back on-line.
11. **Carefully check all connections for any sign of leakage.**

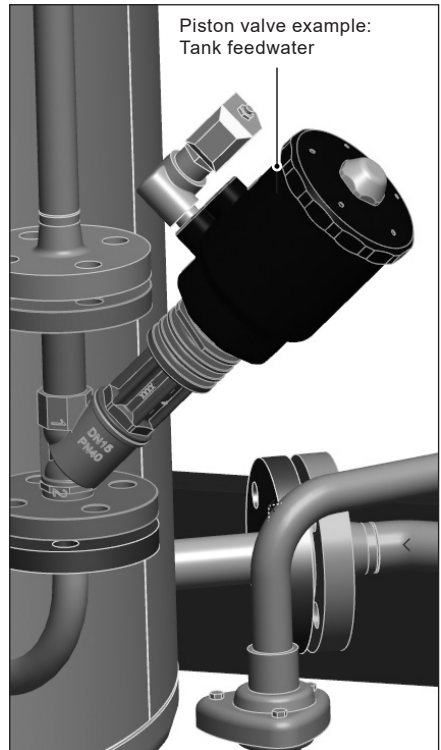

Fig. 19

5.4.10 Control cabinet - Figure 20

The control cabinet provides full control of the Spirax Sarco CSM-E compact clean steam generator operating system. The system requires power to operate, therefore in the case of a power failure, the system will totally shut down the unit. If it is mandatory that the unit remains in operation during power failures, it should be wired into the emergency power system.

Before this is done, it is the duty of the installer / operator or Safety officer to check local codes and requirements to ensure that this is an acceptable configuration.

The system should be checked twice yearly (see the documentation for the system provided with the unit for the specific inspection intervals and test routine). If the system is found to be malfunctioning and it is not possible to identify the fault, the unit must be replaced. To replace the unit please follow the procedure outlined below:

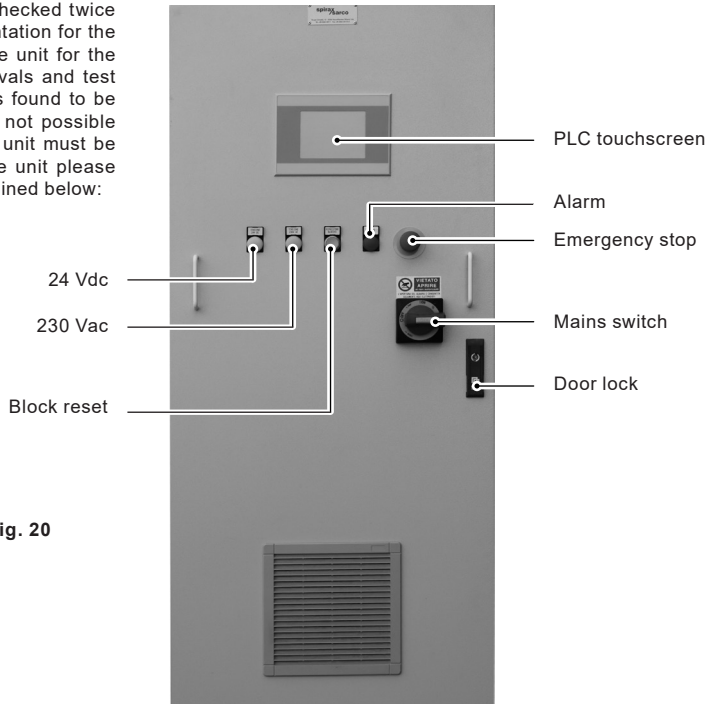

Fig. 20



Note: The exact location and configuration of the solenoid safety system can vary between units. See the drawing and design specifications supplied with the unit for the exact placement and configuration.



The combination of electricity, steam, and water can pose a very dangerous situation. Turn off / disconnect all electric power before attempting any maintenance procedures.

1. Follow the shutdown procedure (Section 4.4) to take the unit off-line before attempting to change any part of the system.
2. Refer to Spirax Sarco technical department for repair or replacement.
3. Follow the start-up procedure (Section 4.2) to put the unit back on-line.
4. **Carefully check all connections for any sign of leakage.**

5.5 Recommended maintenance schedule

Description	Months				
	1	3	6	12	24
Feedtank (if present)					
Remove and inspect the temperature probe. Refit and check calibration.				•	
Remove and inspect the level pressure transducer. Refit with new gasket and check calibration.			•		
Remove, strip and inspect the water inlet control valve. Replace all seals and refit with new gaskets.				•	
Replace filter.				•	
Remove and inspect the electric heating coil. Refit with new gasket.					•

Generator					
Remove and inspect the level controller. Refit and check calibration.			•		
Remove and inspect the pressure transducer. Refit with new gasket and check calibration.			•		
Remove, strip and inspect the water inlet control valve. Replace all seals and refit with new gaskets.				•	
Remove, strip and inspect the bottom blowdown control valve. (if fitted). Replace all seals and refit with new gaskets.				•	
Remove and inspect the electric heating coil. Refit with new gasket.					•
Remove, strip and inspect the clean steam outlet control valve. (if fitted). Replace all seals and refit with new gaskets.				•	
Remove and inspect the generator air vent. Refit with new gaskets.				•	

General					
Remove and inspect all pressure gauges. Refit with new gaskets.				•	
Check the conductivity of the water in the generator.	•				
Carry out steam quality test.		•			
Check all electrical connections.				•	
Carry out full functional check, testing all alarms and operating parameters are correct.		•			

Note: The pump comprises a maintenance free mechanical seal. Therefore there are no specific maintenance requirements.

Note: The Safety valve is factory set at a predetermined limit and requires no maintenance.

6. Bolt torque procedure

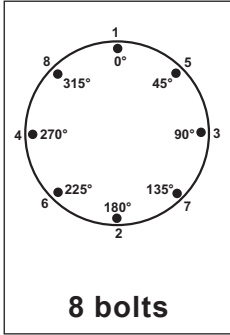

Sequential Order	Rotational Order
1 - 2	1
3 - 4	5
5 - 6	3
7 - 8	7
	2
	6
	4
	8

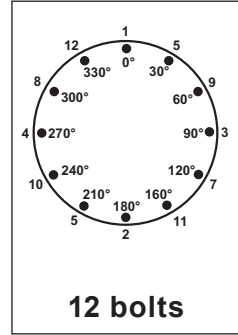

Sequential Order	Rotational Order
1 - 2	1
3 - 4	5
5 - 6	9
7 - 8	3
9 - 10	7
11 - 12	11
	2
	6
	10
	4
	8
	12

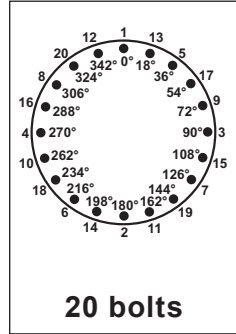
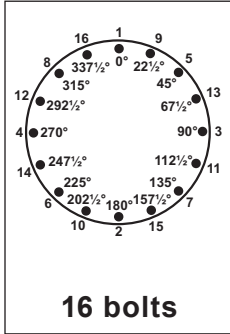

Sequential Order	Rotational Order
1 - 2	1
3 - 4	9
5 - 6	5
7 - 8	13
9 - 10	3
11 - 12	11
13 - 14	7
15 - 16	15
	2
	10
	6
	14
	4
	12
	8
	16

Sequential Order	Rotational Order
1 - 2	1
3 - 4	13
5 - 6	5
7 - 8	17
9 - 10	9
11 - 12	3
13 - 14	15
15 - 16	7
17 - 18	19
19 - 20	11
	2
	14
	6
	18
	10
	4
	16
	8
	20
	12

7. Spare parts

The following is a list of parts that are generally replaceable, by trained / certified personnel, on Spirax Sarco CSM-E electrical compact clean steam generators. However, a full list of the available spares can be provided on request. **The replaceable parts may vary, depending on the unit and the particular design specifications** to which the unit was constructed. If there are questions concerning the replaceable parts for the unit, refer to the original design specifications, or contact Spirax Sarco.

Please have the unit's model number and serial number available when contacting Spirax Sarco (see Section 2.4).

Available spares:

- Gaskets
- Heating coils
- Level controller
- Clean steam pressure gauge
- Pressure safety valve
- Control system

How to order spares

Example: 1 off Level controller for a Spirax Sarco CSM-E electrical compact clean steam generator. Serial number of the generator unit (see Section 2.4):

.....
Serial number (if available) and /or nomenclature (or description) of the component requiring part(s) or replacement:
.....

Repairs

Should it be necessary to return the equipment for repairs please contact our nearest Branch Office or Agent or directly:

Spirax-Sarco S.r.l., Returns Department, Via per Cinisello, 18,
20834 Nova Milanese (MB)
ITALY
Tel.: +39 0362 49 171
Fax: +39 0362 49 17 307

Invalidation of warranty

The partial or total failure to follow the instructions given in this manual completely invalidates the warranty.

8. Fault finding

The following table summarises problems that may be encountered during the life of a CSM-E compact clean steam generator, and the procedures to remedy those problems.

Symptom	Cause	Remedy
<p>1</p> <p>The water level in the tank is too low.</p> <p>The tank is in alarm condition (if present).</p>	No feedwater available.	<p>Check that the water supply treatment plant is running and that water is available.</p> <p>Check that the isolation valve is open.</p>
	<p>The feedwater PAV is closed.</p> <p>The water level controller is damaged and giving a false reading.</p>	<p>Check that the air supply pressure is correct.</p> <p>Check that the PAV solenoid valve is energised.</p> <p>Operate the manual override on the solenoid valve to check the operation of the valve.</p> <p>Manually operate the valve via the tank synoptic screen on the controller.</p> <p>Replace the level controller.</p> <p>Contact Spirax Sarco Service Department</p>
<p>2</p> <p>The water level in the tank is too high.</p> <p>The tank is in alarm condition (if present).</p>	The feedwater PAV has failed to close.	<p>Isolate the feedwater system and inspect the valve seat for signs of damage (see appropriate Installation and Maintenance Instructions).</p>
	<p>The water supply pressure exceeds the maximum differential pressure of the valve.</p> <p>The water level controller is damaged and giving a false reading</p>	<p>Check the water supply pressure.</p> <p>Replace the level controller.</p> <p>Contact Spirax Sarco Service Department.</p>

Symptom	Cause	Remedy
<p style="text-align: center;">3</p> <p style="text-align: center;">The tank temperature is too low (if present).</p>	<p>The heating coil is switched off.</p> <p>The water temperature transducer is damaged and giving a false reading.</p>	<p>Check the electrical connection and the power supply.</p> <p>Replace the temperature transducer.</p> <p>Contact Spirax Sarco Service Department.</p>
<p style="text-align: center;">4</p> <p style="text-align: center;">The tank temperature is too high (if present).</p>	<p>The heating coil has failed to switch off.</p> <p>The water temperature transducer is damaged and giving a false reading.</p>	<p>Shut down the power.</p> <p>Replace the temperature transducer.</p> <p>Contact Spirax Sarco Service Department.</p>
<p style="text-align: center;">5</p> <p style="text-align: center;">The generator water level is too low.</p> <p style="text-align: center;">The generator is in alarm condition.</p>	<p>The feedwater transfer pump is not running.</p> <p>The pump is running but develops no pressure</p>	<p>Check that the pump control isolator is in the run position (RTK1).</p> <p>Check the pump overloads.</p> <p>Check the motor windings (see appropriate Installation and Maintenance Instructions).</p> <p>Replace the pump. See Section 5.4.8 of this manual.</p> <p>Bleed the pump by following the procedure in the relevant Installation and Maintenance Instructions.</p> <p>Adjust the spill back line throttling valve so that sufficient pressure is developed.</p>

Symptom	Cause	Remedy
<p style="text-align: center;">6</p> <p style="text-align: center;">The generator water level is too high. The generator is in alarm condition.</p>	<p>The feedwater PAV has failed to close.</p> <p>The water level controller is damaged and giving a false reading.</p> <p>Steam from a second generator is feeding back into the generator shell and condensing.</p>	<p>Check that the air supply pressure is correct.</p> <p>Check that the PAV solenoid valve is energised.</p> <p>Operate the manual override on the solenoid valve to check the operation of the valve.</p> <p>Manually operate the valve via the generator synoptic screen on the controller.</p> <p>Isolate the feedwater system and inspect the valve seat for signs of damage (see appropriate Installation and Maintenance Instructions).</p> <p>Replace the level controller. See Section 5.4.7 of this manual.</p> <p>Check that the non-return valve is operating correctly.</p> <p>Contact Spirax Sarco Service Department.</p>
<p style="text-align: center;">7</p> <p style="text-align: center;">The generator pressure is too low. The low pressure alarm has activated.</p>	<p>The heating coil is switched off.</p> <p>The generator pressure transducer is damaged and giving a false reading.</p>	<p>Check the electrical connection and the power supply.</p> <p>Replace the pressure transducer.</p> <p>Contact Spirax Sarco Service Department.</p>

Symptom	Cause	Remedy
<p style="text-align: center;">8</p> <p style="text-align: center;">The generator pressure is too high. The generator is in alarm condition.</p>	<p>The heating coil has failed to switch off.</p> <p>The pressure transducer is damaged and giving a false reading.</p>	<p>Shut down the power.</p> <p>Replace the pressure transducer.</p> <p>Contact Spirax Sarco Service Department.</p>
<p style="text-align: center;">9</p> <p style="text-align: center;">The controller touch screen is blank and does not respond when touched.</p>	<p>Power has failed.</p>	<p>Check that the electrical power is on.</p> <p>Contact Spirax Sarco Service Department.</p>
<p style="text-align: center;">10</p> <p style="text-align: center;">The generator is unable to maintain pressure when operating on full-load conditions.</p>	<p>The heating coil is switched off.</p> <p>The clean steam load is exceeding the design specification of the generator.</p>	<p>Check the electrical connection and the power supply.</p> <p>Check the actual steam load against the original specification.</p> <p>Contact Spirax Sarco Service Department.</p>

