

CSF16 and CSF16T Stainless Steel Steam and Sterile Air Filters

How to replace the filter element and seals

Stainless steel steam filters

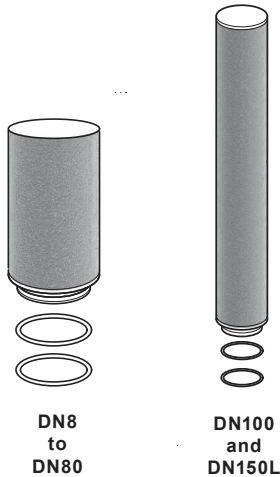

Stainless steel sterile air filters

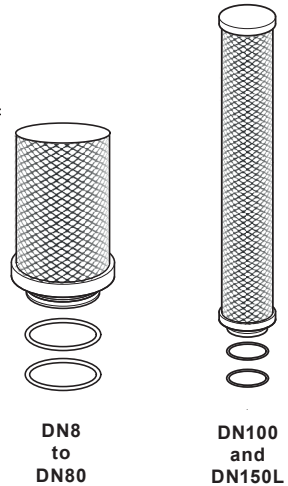

1. Safety information

Safe operation of these products can only be guaranteed if they are properly installed, commissioned, used and maintained by qualified personnel (see Section 1.11) in compliance with the operating instructions. General installation and safety instructions for pipeline and plant construction, as well as the proper use of tools and safety equipment must also be complied with.

This product is intended to be connected into a system that can operate an EC 1935 compliant process.

To minimise the risk of non-intentionally added substances in the system, it is essential that an appropriate CIP (cleaning-in-place) cycle is carried out by the end user prior to first use in a food contact application.

A list of all the materials that could come directly into contact with foodstuffs can be found in the Declaration of Conformity supplied with this product.

1.1 Intended use

- i) The filter element(s) have been validated for use on steam and compressed air systems.
- ii) Ensure the correct filter element(s) and seal material have been selected to suit the application.
- iii) Remove all packaging and protective covers from the product where applicable before installation.

1.2 Access

Ensure safe access and if necessary a safe working platform (suitably guarded) before attempting to work on the product. Arrange suitable lifting gear if required.

1.3 Lighting

Ensure adequate lighting, particularly where detailed or intricate work is required.

1.4 Hazardous liquids or gases in the pipeline

Consider if there is any risk of residual fluids in the pipeline before starting work. Consider if there are any flammable materials, substances hazardous to health, extremes of temperature.

1.5 Hazardous environment around the product

Consider: explosion risk areas, lack of oxygen (e.g. tanks, pits), dangerous gases, extremes of temperature, hot surfaces, fire hazard (e.g. during welding), excessive noise, moving machinery.

1.6 The system

Consider the effect on the complete system of the work proposed. Will any proposed action (e.g. closing isolation valves, electrical isolation) put any other part of the system or any personnel at risk? Dangers might include isolation of vents or protective devices or the rendering ineffective of controls or alarms. Ensure isolation valves are turned on and off in a gradual way to avoid system shocks.

1.7 Pressure systems

Ensure that any pressure is isolated and safely vented to atmospheric pressure. Do not assume that the system has depressurised even when the pressure gauge indicates zero.

1.8 Temperature

Allow time for temperature to normalise after isolation to avoid danger of burns.

1.9 Tools and consumables

Before starting work ensure that you have suitable tools and/or consumables available. Use only genuine Spirax Sarco replacement parts.

1.10 Protective clothing

Consider whether you and/or others in the vicinity require any protective clothing to protect against the hazards of, for example, chemicals, high/low temperature, radiation, noise, falling objects, and dangers to eyes and face.

1.11 Permits to work

All work must be carried out or be supervised by a suitably competent person. Installation and operating personnel should be trained in the correct use of the product according to the Installation and Maintenance Instructions.

Where a formal 'permit to work' system is in force it must be complied with. Where there is no such system, it is recommended that a responsible person should know what work is going on and, where necessary, arrange to have an assistant whose primary responsibility is safety. Post 'warning notices' if necessary.

1.12 Handling

Manual handling of large and/or heavy products may present a risk of injury. Lifting, pushing, pulling, carrying or supporting a load by bodily force can cause injury particularly to the back. You are advised to assess the risks taking into account the task, the individual, the load and the working environment and use the appropriate handling method depending on the circumstances of the work being done.

1.13 Residual hazards

In normal use the external surface of the product may be very hot. If used at the maximum permitted operating conditions the surface temperature may reach temperatures in excess of 220 °C (428 °F). Many products are not self-draining. Take due care when dismantling or removing the product from an installation (refer to 'Maintenance instructions').

1.14 Freezing

Provision must be made to protect products which are not self-draining against frost damage in environments where they may be exposed to temperatures below freezing point.

1.15 Disposal

The product is recyclable. No ecological hazard is anticipated with the disposal of this product providing due care is taken.

1.16 Returning products

Customers and stockists are reminded that under EC Health, Safety and Environment Law, when returning products to Spirax Sarco they must provide information on any hazards and the precautions to be taken due to contamination residues or mechanical damage which may present a health, safety or environmental risk. This information must be provided in writing including Health and Safety data sheets relating to any substances identified as hazardous or potentially hazardous.

2. Fitting and replacement of filter elements

Note: Before undertaking any maintenance, observe the 'Safety information' in Section 1.

2.1 General information

Before undertaking any maintenance on the filter, it must be isolated from both the supply line and return line and any pressure allowed to safely normalise to atmosphere. The filter should then be allowed to cool. When reassembling, ensure that all joint faces are clean.

Warning: The steam filter elements CSF16 -SE and CSF16 - SF must never be subjected to more than 5 bar g differential pressure.

See IM-P180-42 Section 6.1 for service life information.

2.2 How to replace the filter element(s)

See Figure 1 Stainless steel steam filters on page 6 for part recognition.

See Figure 2 Stainless steel sterile air filters on page 7 for part recognition.



Remove the filter element (5) by carefully pulling it upwards and repeat if multiple elements fitted.

Once the pipework installation has been completed in accordance with Section 3 (Fig. 5 or 6) the following steps should be taken in sequence, referencing Fig. 7 and 8, to commission the CSF16 and CSF16T filters:

Note: The top and bottom plugs (where supplied) are hand tightened only. If an air vent and trap are not connected as per the recommended installation guidance above, ensure that the plugs are tightened to the torque values shown in the torque table 1.

1. All isolating valves should be closed.
2. The housing ring (4) or housing bolts (10) holding together the filter housing head (2) and the filter housing bowl (1) should be unscrewed using the appropriate spanner. The filter housing head (2) can then be removed.
3. Remove the filter element (5) by carefully pulling it upwards and repeat if multiple elements fitted.

Table 1 Recommended tightening torques

Item	Part	 or 	mm	N m
4		use C spanner		As required
7	DN8 - DN80	6 mm Hex	G¼"	55
	DN100 and DN150L	A/F 42	G1"	138
10	DN100	A/F 30	M20	180
	DN150L	A/F 30	M20	260

4. The new filter element seals (2 off, item **6**) should then be lubricated using a lubricant suitable for the application, before fitting to the filter housing bowl (**1**).
5. The filter element needs to be gently pushed into the filter housing bowl (**1**).
6. **When multiple elements are fitted**, the filter support assembly (**11**) must be assembled and fitted as shown in Figure 2.
7. Ensure the filter housing seal (**3**) is fitted.
8. **For sizes DN8 to DN80:** The housing ring (**4**) should then be carefully placed into the seating land on the filter housing head (**2**), before then gently lowering the filter housing bowl (**1**) over the filter element and tightening the housing ring (**4**). The housing ring (**4**) is designed with a coarse thread to minimise the possibility of galling. Thread lubrication is not normally necessary. However, a thread lubricant may be used if required.
9. **For sizes DN100 and DN150:** Gently lower the housing head (**2**) over the filter elements and place it onto the housing bowl (**1**). Tighten the housing bolts to the recommended torque - see Table 1.
10. Once Steps 1-9 have been completed the upstream isolating valve can be cracked open slowly to introduce the medium into the CSF16 or CSF16T filter then proceed with Steps 11 to 14.
11. If on gas or steam service an audible signal (whistling tone) is heard then the filter housing has been incorrectly assembled and the upstream isolating valve should be closed immediately.

Warning

Before opening housing ensure it has cooled and that any residual pressure within has been discharged.

Once this has happened the housing ring (**4**) or housing bolts (**10**) can be undone, the filter housing bowl and head (**1** and **2**) plus filter element (**5** - please note that there are multiple elements for the larger sizes) and especially the filter housing seal (**3**) can be carefully checked, before reassembly.

12. **Should no audible signal be heard after the upstream isolating valve has been opened**, then the downstream valve can be opened slowly until fully open. The medium will now be flowing through the CSF16 or CSF16T filter and at this stage a note should be taken of the pressure gauge readings before and after the CSF16 or CSF16T filter, in order to check the differential pressure. The date of installation should be noted.
13. All interconnecting pipework, fixtures and fittings should then be checked for leakage especially if steam is the operating medium. This check should include steam traps.
14. **Within the first few days following filter element replacement**, the filter housing should be isolated and the strainer preceding the filter housing checked by removing the screen. Any pipe debris can be removed or the strainer screen can be replaced.

2.3 Stainless steel steam filters

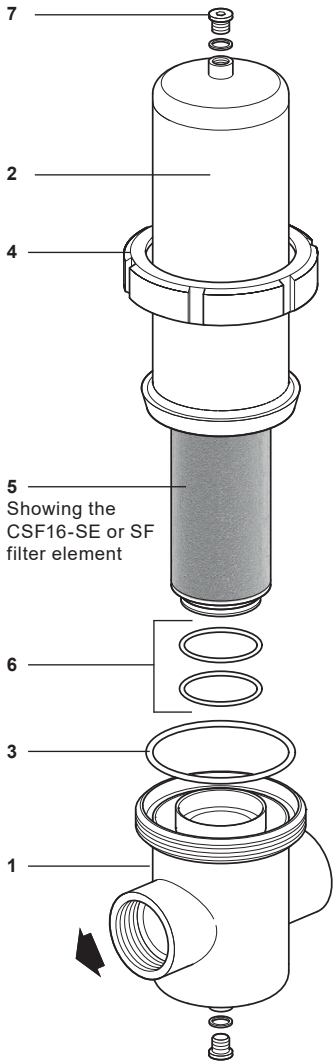

Fig. 1 DN8 to DN80

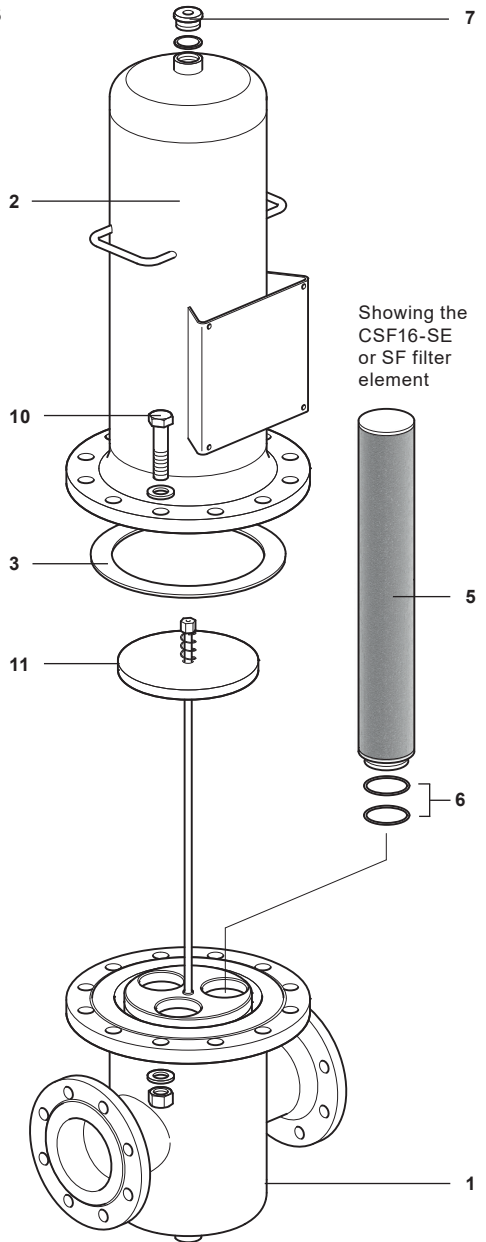

Fig. 2 DN100 and DN150L
(image shows DN100L)

2.4 Stainless steel sterile air filters

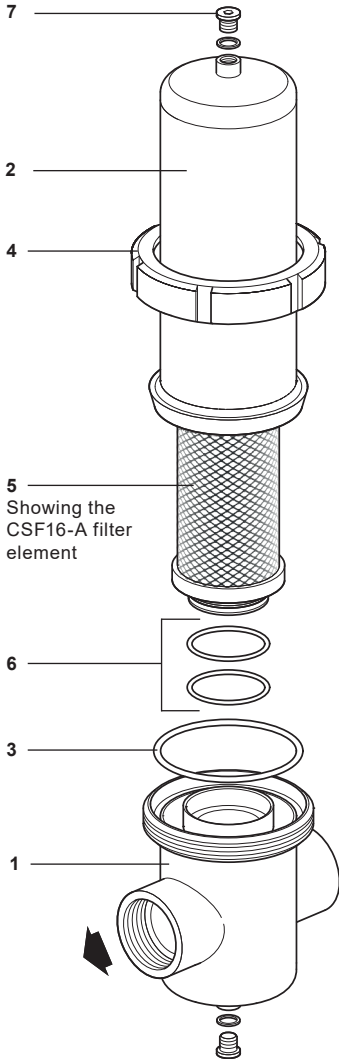

Fig. 3 DN8 to DN80

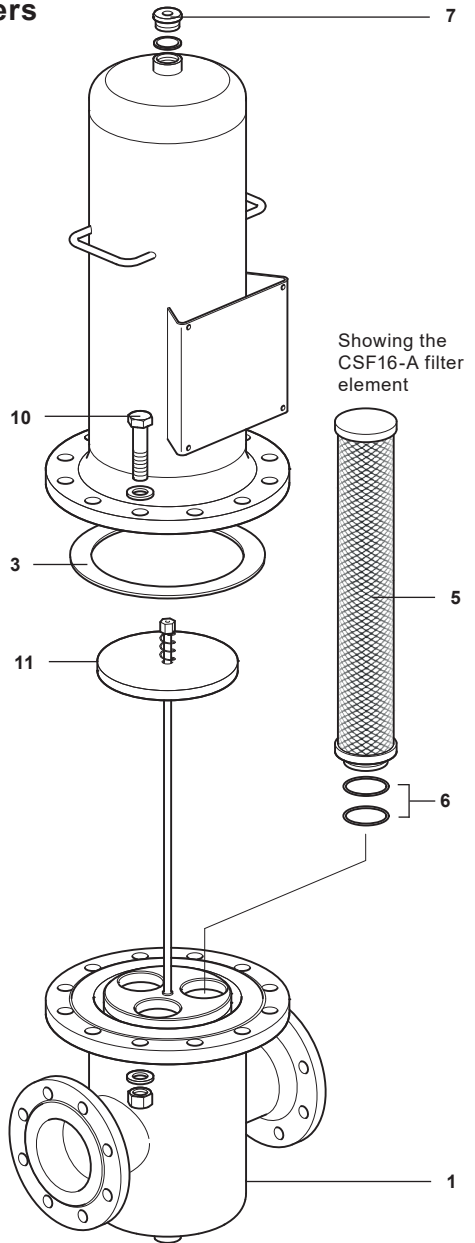

Fig. 4 DN100 and DN150L
(image shows DN100L)

