

CP42
Conductivity Probe
Installation and Maintenance Instructions

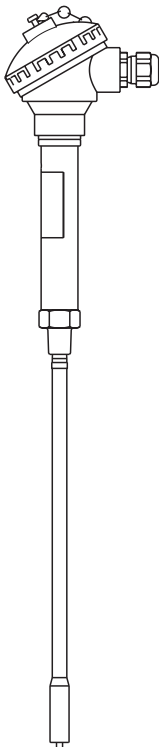

1. Safety information
2. General product information
3. Installation
4. Wiring diagrams
5. Maintenance
6. Spare parts
7. Fault finding
8. Technical assistance

1. Safety information

Safe operation of these products can only be guaranteed if they are properly installed, commissioned, used and maintained by qualified personnel (see Section 1.11) in compliance with the operating instructions. General installation and safety instructions for pipeline and plant construction, as well as the proper use of tools and safety equipment must also be complied with.

Do not install the probe outdoors without additional weather protection.

Drain/vent holes must be kept clean - do not cover.

1.1 Intended use

Referring to the Installation and Maintenance Instructions, name-plate and Technical Information Sheet, check that the product is suitable for the intended use/application.

The conductivity probe CP42 is designed for use with Spirax Sarco conductivity controllers. If used in conjunction with other controllers then a safety power supply unit that delivers a Safety Extra Low Voltage (SELV) must be used to supply the controller/probe.

The CP42 Conductivity probe and the BCR3250 comply with the requirements of the Pressure Equipment Directive (PED) and carry the  Mark.

The blow-down control and monitoring equipment is EU type approved according to EN12952/EN12953. these directives state, among other things, the requirements made on limiting systems and equipment for steam boiler plants and (pressurized) hot water applications

- i) The products have been specifically designed for use on steam and water. The products' use on other fluids may be possible but, if this is contemplated, Spirax Sarco should be contacted to confirm the suitability of the product for the application being considered.
- ii) Check material suitability, pressure and temperature and their maximum and minimum values. If the maximum operating limits of the product are lower than those of the system in which it is being fitted, or if malfunction of the product could result in a dangerous overpressure or overtemperature occurrence, ensure a safety device is included in the system to prevent such over-limit situations.
- iii) Determine the correct installation situation and direction of fluid flow.
- iv) Spirax Sarco products are not intended to withstand external stresses that may be induced by any system to which they are fitted. It is the responsibility of the installer to consider these stresses and take adequate precautions to minimise them.
- v) Remove protection covers from all connections and protective film from all name-plates, where appropriate, before installation on steam or other high temperature applications.

1.2 Access

Ensure safe access and if necessary a safe working platform (suitably guarded) before attempting to work on the product. Arrange suitable lifting gear if required.

1.3 Lighting

Ensure adequate lighting, particularly where detailed or intricate work is required.

1.4 Hazardous liquids or gases in the pipeline

Consider what is in the pipeline or what may have been in the pipeline at some previous time. Consider: flammable materials, substances hazardous to health, extremes of temperature.

1.5 Hazardous environment around the product

Consider: explosion risk areas, lack of oxygen (e.g. tanks, pits), dangerous gases, extremes of temperature, hot surfaces, fire hazard (e.g. during welding), excessive noise, moving machinery.

1.6 The system

Consider the effect on the complete system of the work proposed. Will any proposed action (e.g. closing isolation valves, electrical isolation) put any other part of the system or any personnel at risk?

Dangers might include isolation of vents or protective devices or the rendering ineffective of controls or alarms. Ensure isolation valves are turned on and off in a gradual way to avoid system shocks.

1.7 Pressure systems

Ensure that any pressure is isolated and safely vented to atmospheric pressure. Consider double isolation (double block and bleed) and the locking or labelling of closed valves. Do not assume that the system has depressurised even when the pressure gauge indicates zero.

1.8 Temperature

Allow time for temperature to normalise after isolation to avoid danger of burns.

If parts made from the PTFE have been subjected to a temperature approaching 260 °C (500 °F) or higher, they will give off toxic fumes, which if inhaled are likely to cause temporary discomfort. It is essential for a no smoking rule to be enforced in all areas where PTFE is stored, handled, or processed as persons inhaling the fumes from burning tobacco contaminated with PTFE particles can develop 'polymer fume fever'.

1.9 Tools and consumables

Before starting work ensure that you have suitable tools and/or consumables available. Use only genuine Spirax Sarco replacement parts.

1.10 Protective clothing

Consider whether you and/or others in the vicinity require any protective clothing to protect against the hazards of, for example, chemicals, high/low temperature, radiation, noise, falling objects, and dangers to eyes and face.

1.11 Permits to work

All work must be carried out or be supervised by a suitably competent person. Installation and operating personnel should be trained in the correct use of the product according to the Installation and Maintenance Instructions.

Where a formal 'permit to work' system is in force it must be complied with. Where there is no such system, it is recommended that a responsible person should know what work is going on and, where necessary, arrange to have an assistant whose primary responsibility is safety.

Post 'warning notices' if necessary.

1.12 Handling

Manual handling of large and/or heavy products may present a risk of injury. Lifting, pushing, pulling, carrying or supporting a load by bodily force can cause injury particularly to the back. You are advised to assess the risks taking into account the task, the individual, the load and the working environment and use the appropriate handling method depending on the circumstances of the work being done.

1.13 Residual hazards

In normal use the external surface of the product may be very hot. If used at the maximum permitted operating conditions the surface temperature of some products may reach temperatures of 350 °C (662 °F).

Many products are not self-draining. Take due care when dismantling or removing the product from an installation (refer to 'Maintenance instructions').

1.14 Freezing

Provision must be made to protect products which are not self-draining against frost damage in environments where they may be exposed to temperatures below freezing point.

1.15 Disposal

Unless otherwise stated in the Installation and Maintenance Instructions, this product is recyclable and no ecological hazard is anticipated with its disposal providing due care is taken, except:

PTFE:

- Can only be disposed of by approved methods, not incineration.
- Keep PTFE waste in a separate container do not mix it with other rubbish, and consign it to a landfill site.

1.16 Returning products

Customers and stockists are reminded that under EC Health, Safety and Environment Law, when returning products to Spirax Sarco they must provide information on any hazards and the precautions to be taken due to contamination residues or mechanical damage which may present a health, safety or environmental risk. This information must be provided in writing including Health and Safety data sheets relating to any substances identified as hazardous or potentially hazardous.

2. General product information

2.1 Application

The Spirax Sarco CP42 conductivity probe is used in conjunction with a controller to measure the conductivity (closely related to TDS) of water, usually in a steam boiler, for the purpose of monitoring and controlling blowdown.

2.2 Description

The CP42 is supplied in three nominal tip lengths, and has a $\frac{3}{8}$ " BSP thread for connecting to a Spirax Sarco probe elbow, a screwed flange, or directly into a boiler connection.

The CP42 has a built-in temperature sensor, and when used with an appropriate controller, is able to detect scaling. It also automatically initiates a probe conditioning cycle.

This causes any scale on the probe to become porous or disintegrate, allowing the probe to continue to sense at its original calibration level. **WARNING: This feature is not a substitute for a proper boiler water treatment regime. If scale is present on a probe, it indicates scaling is also occurring inside the boiler, and a competent water treatment specialist must be consulted to avoid a potentially dangerous situation.**

2.3 Available tip lengths mm (inches)

300 (11.8), 500 (19.7) and 1000 (39.4)

Note: 1000 mm probes must only be installed vertically.

2.4 Pressure/temperature limits

Maximum boiler pressure	32 bar g	(464 psi g)
Maximum operating temperature	239 °C	(462 °F)
Maximum ambient temperature	70 °C	(158 °F)

2.5 Technical data

Minimum tip distance from boiler tubes	10 mm	($\frac{3}{8}$ ")
Minimum immersion depth (vertically installed probes)	100 mm	(4")
See controller IMI for wiring diagrams and minimum conductivity		
Degree of protection	IP54	

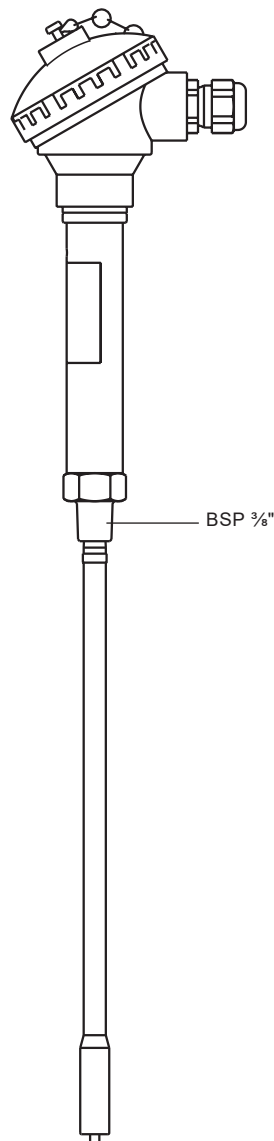

Fig. 1

3. Installation

The CP42 is supplied in nominal tip lengths of 300, 500, or 1000 mm, (12", 20" and 39") and cannot be cut to length.

300 mm and 500 mm probes can be installed vertically or horizontally.

CAUTION: 1000 mm probes must be installed vertically only.

WARNING: Do not install the probe outdoors without additional weather protection.

WARNING: The boiler must be depressurised and vented to atmosphere before installation of the probe. Wherever possible the boiler manufacturer must be consulted for advice on the positioning of the probe and the optimum TDS level.

Always install the probe:

- In a position where it can sense the conductivity of the boiler water.
- As far away from the feedwater inlet as possible.
- As near to the centre line of the boiler as possible. This lowers the risk of it being in the steam bubbles normally found towards the top of the boiler, or in the higher concentration of suspended solids found at the bottom of the boiler.

Note: The tip of the probe must be 10 mm ($\frac{3}{8}$ ") away from any boiler tubes and project at least 55 mm ($2\frac{1}{8}$ ") into the boiler. It may be necessary to make up a stand-off for certain installations in order to achieve these measurements. Vertically installed probes must be immersed to a minimum depth of 100 mm (4").

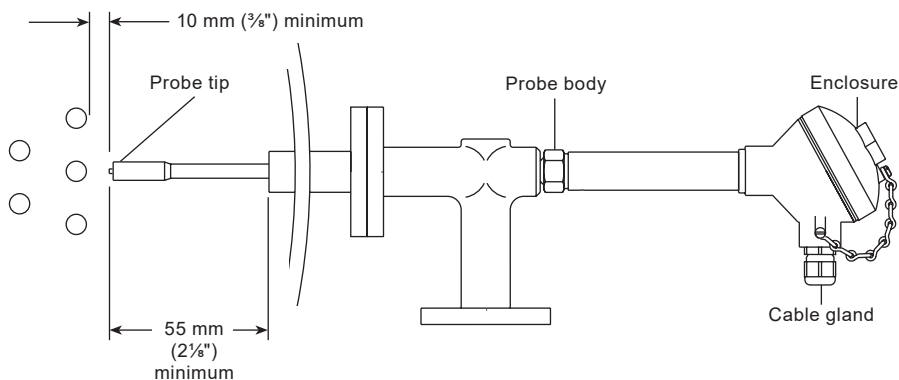

Fig. 2 Installation diagram

Install the probe as follows:

- Ensure male and female threads are in good condition.
- Use up to three turns (no more) of PTFE thread sealing tape on the probe thread.
WARNINGS: Do not use excessive tape. Do not use paste type jointing compound.
- Fit and tighten the probe by hand initially. Use a suitable spanner to tighten the probe.
- Due to the nature of a taper/parallel joint it is not possible to recommend tightening torque figures.
- Do not overtighten - there should always be visible thread on the probe.

Note: The probe thread will not 'bottom out' (i.e. probe body hexagon contacts the face of the female screwed connection), unless there is excessive wear or an out-of-tolerance female thread, in which case it will be necessary to replace or re-work the flange or connection.

- Take care not to damage the probe insulation sleeve when fitting the probe to the boiler.

Subsequent removal and refitting:

WARNING: Ensure boiler or vessel is depressurised and vented to atmosphere before attempting to unscrew or remove the probe.

- Always use the correct size spanner.
- Inspect male and female threads for signs of damage, which may have occurred through overtightening, leading to torn threads or even localised cold welding (galling/picking up).
- If damage has occurred replace the probe.
- Check that the probe insulation is not torn or damaged.

4. Wiring diagrams

Cabling should be installed in accordance with BS 6739 - Instrumentation in Process Control Systems : Installation design and practice or local equivalent. For US and Canadian installations the probe must be wired in accordance with the National and Local Electrical Code (NEC) or the Canadian Electrical Code (CEC). An 8-way terminal block is provided in the terminal head to simplify wiring. The terminal block accepts wires with conductor cross section of 0.01 - 1.31 mm² (28 - 16 AWG).

See controller IMI for further wiring details.

For US and Canadian installations, Class 1 screened cable with a suitable temperature rating (75 °C/167 °F minimum) must be used for the wiring.

Connect the wiring and screens as shown in the diagrams below.

Caution: Do not connect any wires to the smaller (five-way) terminal block, as it houses the very fine wiring from the probe which could be easily damaged in attempting to connect additional wires.

Wiring should be carried out using 5 core, 0,5 mm² (20 AWG), high temperature screened cable, with a maximum length of: 10 m for 0 – 10 µS/cm and 30 m for 10 - 10000 µS/cm. For example, LiYCY 5 x 0,5mm²

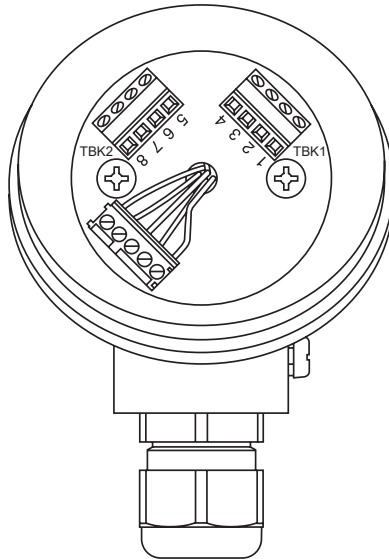

Fig. 3 Wiring layout

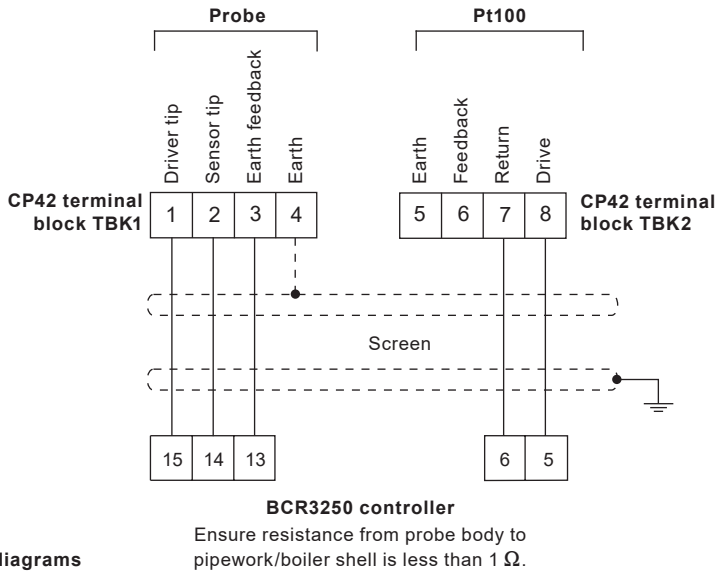

Fig. 4 Wiring diagrams

5. Maintenance

The probe does not normally need regular maintenance. Remove, clean, and check the probe annually.

We also recommend that if the controller ever indicates a fault condition for over 12 hours that it is removed, checked, and cleaned.

If scale should start to form on the probe, then it will normally be removed/made conductive by the automatic conditioning system. However, this system is not a substitute for adequate water treatment. It is still possible that under very severe conditions the probe may need extra cleaning.

To clean the probe tip manually

Probe body cleaning instructions - Use a cloth dampened with tap/de-ionised water or isopropyl alcohol. Use of other cleaning materials could damage the product and invalidate the warranty.

Caution: The probe contains no user-serviceable components - any attempt to dismantle the unit will result in permanent damage.

Remove the probe and clean with a wet cloth. For hard scale, fine wet-or-dry paper (600 grit maximum coarseness) may be used on the tip. **Do not use abrasives on the sleeve.**

If excessive corrosion occurs at the probe tip, it may be necessary to replace the probe.

Refit the probe using PTFE tape rather than paste-type compound. See Section 3 'Installation'.

6. Spare parts

There are **no available spare parts** for this product.

7. Fault finding

Problems experienced during commissioning are often found to be due to incorrect wiring or setting up, so we recommend that a thorough check is first carried out.

Checking probe condition using the probe cell constant:-

The controllers have a facility which allows the condition of the probe driver tip to be checked without removing the probe from the boiler. This is done by calculating an approximation of the probe cell constant, an indication of the probe condition.

A probe driver tip which is functioning correctly without excessive scaling will have a cell constant of between 0.2 and 0.6. See the 'Fault finding' Section of the Installation and Maintenance Instructions for details.

The **sensor tip condition** cannot be checked by the following blowdown controllers but it **can be checked by using the MS1 conductivity meter**.

Checking the probe condition using the MS1:-

The condition of an installed probe can be checked by using a Spirax Sarco MS1 conductivity meter and its extension lead.

Driver tip:

- Connect the MS1 extension lead between terminal 1 and terminal 3.
- Use the reading to calculate the driver tip cell constant as described in the MS1 instructions. A cell constant in the region of 0.2 to 0.6 would indicate that the probe is working correctly. A high figure indicates that the probe is scaled.

Sensor tip:

- As for driver tip, but connect the MS1 between terminals 2 and 3.
A sensor tip cell constant of 0.2 to 0.6 is normal, but a figure up to 0.8 is satisfactory.

Pt100 resistance check:

- The power must be off for this check.
- Measure the resistance between terminal 7 and terminal 8. A conventional ohm meter may be used for this test. Resistance should be between 100 ohms (0 °C/32 °F) and 168 ohms (180 °C/356 °F). Terminal 3 should be earthed to the probe body.

8. Technical assistance

Contact your local Spirax Sarco representative. Details can be found on accompanying order/delivery documentation or on our web site:

www.spiraxsarco.com

Returning faulty equipment

Return all items to your local Spirax Sarco representative. Ensure all items are suitably packed for transit (preferably in the original cartons).

Please provide the following information with any equipment being returned:

1. Your name, company name, address and telephone number, order number and invoice and return delivery address.
2. Description and serial number of equipment being returned.
3. Full description of the fault or repair required.
4. If the equipment is being returned under warranty, please indicate:
 - a. Date of purchase.
 - b. Original order number.

Spirax Sarco Ltd
Runnings Road
Cheltenham
GL51 9NQ
United Kingdom

www.spiraxsarco.com

CP42 Conductivity Probe

