

Colima TOR
Magnetic Level Switches
Installation and Maintenance Instructions

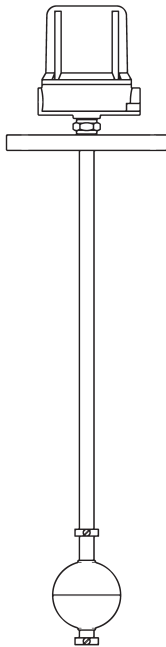

- 1. Safety information
- 2. General product information
- 3. Installation and Maintenance
- 4. Contacts
- 5. Transmitter
- 6. Spare parts

1. Safety information

Safe operation of these products can only be guaranteed if they are properly installed, commissioned, used and maintained by qualified personnel (see Section 1.11) in compliance with the operating instructions. General installation and safety instructions for pipeline and plant construction, as well as the proper use of tools and safety equipment must also be complied with.

1.1 Intended use

Referring to the Installation and Maintenance Instructions, name-plate and Technical Information Sheet, check that the product is suitable for the intended use/application. The products comply with the requirements of the European Pressure Equipment Directives: ATEX 94/9/CE and European Pressure Equipment Directive 2014/68/EU falling within category 'SEP'. It should be noted that

products within this category are required by the Directive not to carry the  mark.

Products intended for use in the Naval and Marine sectors are RINA, and M.M.I (Italian navy) approved.

- i) The products have been specifically designed for use on steam, compressed air and inert industrial gases which are in Group 2 of the above mentioned Pressure Equipment Directive. The products' use on other fluids may be possible but, if this is contemplated, Spirax Sarco should be contacted to confirm the suitability of the product for the application being considered.
- ii) Check material suitability, pressure and temperature and their maximum and minimum values. If the maximum operating limits of the product are lower than those of the system in which it is being fitted, or if malfunction of the product could result in a dangerous overpressure or overtemperature occurrence, ensure a safety device is included in the system to prevent such over-limit situations.
- iii) Determine the correct installation situation and direction of fluid flow.
- iv) Spirax Sarco products are not intended to withstand external stresses that may be induced by any system to which they are fitted. It is the responsibility of the installer to consider these stresses and take adequate precautions to minimise them.
- v) Remove protection covers from all connections and protective film from all name-plates, where appropriate, before installation on steam or other high temperature applications.

1.2 Access

Ensure safe access and if necessary a safe working platform (suitably guarded) before attempting to work on the product. Arrange suitable lifting gear if required.

1.3 Lighting

Ensure adequate lighting, particularly where detailed or intricate work is required.

1.4 Hazardous liquids or gases in the pipeline

Consider what is in the pipeline or what may have been in the pipeline at some previous time. Consider: flammable materials, substances hazardous to health, extremes of temperature.

1.5 Hazardous environment around the product

Consider: explosion risk areas, lack of oxygen (e.g. tanks, pits), dangerous gases, extremes of temperature, hot surfaces, fire hazard (e.g. during welding), excessive noise, moving machinery.

1.6 The system

Consider the effect on the complete system of the work proposed. Will any proposed action (e.g. closing isolation valves, electrical isolation) put any other part of the system or any personnel at risk? Dangers might include isolation of vents or protective devices or the rendering ineffective of controls or alarms. Ensure isolation valves are turned on and off in a gradual way to avoid system shocks.

1.7 Pressure systems

Ensure that any pressure is isolated and safely vented to atmospheric pressure. Consider double isolation (double block and bleed) and the locking or labelling of closed valves. Do not assume that the system has depressurised even when the pressure gauge indicates zero.

1.8 Temperature

Allow time for temperature to normalise after isolation to avoid danger of burns and consider whether protective clothing (including safety glasses) is required.

1.9 Tools and consumables

Before starting work ensure that you have suitable tools and/or consumables available. Use only genuine Spirax Sarco replacement parts.

1.10 Protective clothing

Consider whether you and/or others in the vicinity require any protective clothing to protect against the hazards of, for example, chemicals, high/low temperature, radiation, noise, falling objects, and dangers to eyes and face.

1.11 Permits to work

All work must be carried out or be supervised by a suitably competent person.

Installation and operating personnel should be trained in the correct use of the product according to the Installation and Maintenance Instructions.

Where a formal 'permit to work' system is in force it must be complied with. Where there is no such system, it is recommended that a responsible person should know what work is going on and, where necessary, arrange to have an assistant whose primary responsibility is safety. Post 'warning notices' if necessary.

1.12 Handling

Manual handling of large and/or heavy products may present a risk of injury. Lifting, pushing, pulling, carrying or supporting a load by bodily force can cause injury particularly to the back. You are advised to assess the risks taking into account the task, the individual, the load and the working environment and use the appropriate handling method depending on the circumstances of the work being done.

1.13 Residual hazards

In normal use the external surface of the product may be very hot. If used at the maximum permitted operating conditions the surface temperature of some products may reach temperatures of 350 °C. Many products are not self-draining. Take due care when dismantling or removing the product from an installation (refer to 'Maintenance instructions').

1.14 Freezing

Provision must be made to protect products which are not self-draining against frost damage in environments where they may be exposed to temperatures below freezing point.

1.15 Disposal

This product is recyclable. No ecological hazard is anticipated with the disposal of this product providing due care is taken.

Please visit the Spirax Sarco product compliance web pages

<https://www.spiraxsarco.com/product-compliance>

for up to date information on any substances of concern that may be contained within this product. Where no additional information is provided on the Spirax Sarco product compliance web page, this product may be safely recycled and/or disposed providing due care is taken. Always check your local recycling and disposal regulations.

1.16 Returning products

Customers and stockists are reminded that under EC Health, Safety and Environment Law, when returning products to Spirax Sarco they must provide information on any hazards and the precautions to be taken due to contamination residues or mechanical damage which may present a health, safety or environmental risk. This information must be provided in writing including Health and Safety data sheets relating to any substances identified as hazardous or potentially hazardous.

2. General product information

2.1 Description

The Colima TOR magnetic-activated level switch is designed to control the liquid levels in most industrial applications. The unit comprise of a rigid rod for vertical installation that is used for full automatic management of tanks (including pressurised ones) allowing operations such as starting/stopping of pumps, opening/closing of solenoid valves and activation of alarm systems.

One unit can be used with up to six switching points or with a potentiometer transmitter for a continuous reading of the level.

2.1.1 Mounting

The Colima TOR magnetic level switch is designed for top mounting directly to the tank. It can be installed vertically directly into the tank, or externally into a chamber connected to the tank.

2.1.2 Standards and certification

The Colima TOR magnetic level switch complies with the following European Directives:

- ATEX 94/9/EC
- European Pressure Equipment Directive 2014/68/EU
- Products intended for use in the Naval and Marine sectors are RINA, and M.M.I (Italian navy) approved.

2.1.3 Operation

The level switch is secured to the tank by means of a flange or a thread. One or more magnetic contacts (reed switches) or a reed switch "chain" potentiometer transmitter are placed inside a sealed vertical tube, joined to the locking system.

Contacts

One or more float(s), free to slide along the guide tube depending on the liquid level inside the tank, acting magnetically on contacts placed at the operation point, switching their status from NO to NC or vice versa.

The switching of the electrical contact is quick and reliable.

Switching points are always field adjustable.

Transmitter

A float, free to slide along the guide tube depending on the liquid level inside the tank, acts magnetically on the transmitter. The level is continuously transmitted.

2.2 Materials

No.	Part	Material
1	Housing	Aluminium Rilsan coated/ Stainless steel
2a	Terminal board	Melamina
2b	4 - 20 mA output converter	Plastic
3/4	Flange or thread	304/316L/PVC/PP/PVDF Lowest applicable nominal diameter 50 mm (2") with nominal pressure related to design needs.
5	Tube and wetted parts	316L /PVC/PP/PVDF
6	Float	316L /Titanium/Monel/Hastelloy/PVC/PP/PVDF/BunaN
7a	Contact	SPDT or DPDT ermetically sealed, golden plated
7b	Transmitter chain (not shown)	SPDT ermetically sealed, golden plated
8	Chamber (not shown)	A105/304/316L

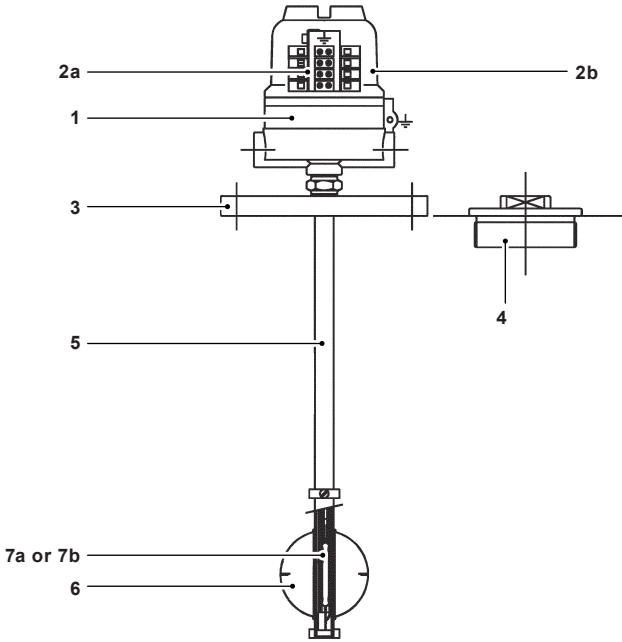

2.3 Design conditions

TMA	Maximum allowable temperature	Steel	-110 °C to +200 °C	
		Buna N	-20 °C to + 80 °C	
		PVC	-20 °C to + 70 °C	
		Plastic	PP	-20 °C to +105 °C
		PVDF	-20 °C to +130 °C	
PMA	Maximum allowable pressure	Steel	< 100 bar g	
		Buna N	< 16 bar g	
		Plastic	< 16 bar g	
Fluid specific gravity		Steel and plastic	> 0.8 kg/l	
		Buna N/Titanium	> 0.5 kg/l	
Differential			fixed 8 mm	

Materials and sizing are defined in relation to the characteristics of the liquid and the project conditions.

Rod length

Minimum length 100 mm

Maximum length 5000 mm

2.4 Models

TOR A



Type recommended for most industrial applications. All wetted parts are made totally of stainless steel. Equipped with reed switches, which allows control of up to six switching points with a single instrument. Equipped with a potentiometer transmitter allowing continuous reading of liquid level.

TOR B



Type recommended for liquids with low specific weight such as hydrocarbons and mineral oils. Floats in BUNA N, the other wetted parts are made totally of stainless steel. Equipped with reed switch contacts, which allows the control of up to six switching points with a single instrument. Equipped with a potentiometer transmitter allowing the continuous reading of the liquid level.

TOR CD



Compact type, recommended for applications in hydraulic control units.
It can also be used with liquids with low specific weight such as hydrocarbons and mineral oils.
Stainless steel or BUNA N floats, the other wetted parts are made of stainless steel. Can be equipped with reed switch contacts, allowing control of up to two switching points with a single instrument.
In place of the housing, a three-pin DIN connector with flying plug is used.

TOR PC



Type indicated for corrosive liquids, such as acids and brines, where the use of stainless steel is not recommended. All wetted parts are made totally of PVC-Polyvinylchloride.
Equipped with reed switch contacts, PC allows the control of up to six switching points with a single instrument.
Equipped with a potentiometer transmitter allowing the continuous reading of the liquid level.

Models continued on next page

TOR PP



Type indicated for corrosive liquids, such as acids and brines, where the use of stainless steel is not recommended. All wetted parts are made totally of PP-Polypropylene. Equipped with reed switches, which allows control of up to six switching points with a single instrument. Equipped with a potentiometer transmitter allowing continuous reading of liquid level.

TOR PF



Type indicated for corrosive liquids, such as acids and brines, where the use of stainless steel is not recommended. All wetted parts are made totally of PVDF-Polyvinylidene fluoride. Equipped with reed switch contacts, which allows control of up to six switching points with a single instrument. Equipped with a potentiometer transmitter allowing continuous reading of liquid level.

3. Installation and Maintenance

Note: Before actioning any installation or maintenance work observe the 'Safety information' in Section 1.

Referring to the Installation and Maintenance Instructions, name-plate and Technical Information Sheet, check that the product is suitable for the intended installation.

Check: materials, pressure and temperature to ensure compatibility of the product with the required application.

Remove protective covers from all connections and the protective film from the name-plate.

3.1 Assembly

The Colima TOR magnetic level switches are delivered packed.

Caution before installation disassemble the lower flange and remove the float from its package + **Confirm** the presence of supplied gaskets.

3.1.1 Fit the level switch in the tank paying attention to avoid any damage to the float. Any damage of the float can interfere with the correct operation of the unit.

3.1.2 Place the supplied gaskets between the flanges or thread.

3.1.3 Flange mount: Place the supplied gasket between the flanges. Fix the flanges with bolts and firmly secure the fixing by tightening the flange bolts.

Thread mount: Place the gasket in situ and use PTFE tape on the thread of the joint and firmly secure the fixing by tightening with a spanner.

3.1.4 Ensure that there is nothing stopping the correct operation of the float.

3.1.5 Open the unit housing and connect the wiring at the terminal board.

The housing has two cable entry points:

G ½" F, Explosion-proof Gk ½" F, ½" NPT F, M 20 x1.5, PG 13.5

Caution: Always ensure that correct earthing of the equipment is carried out. Specific points are set inside and outside the housing.

Explosion-proof housing operating limits

Technical data	Class I: simple protective-earth connection requirements
-----------------------	--

Employment data for potentially explosive atmospheres

Ambient temperature limits	-20 °C to +50 °C	
Marking	 II 1/2 G EEx d II C T6, T5 resp. T4	
Temperature class	T6	T4
Permitted temperature variation range	-20 °C to +40 °C	-20 °C to +80 °C
Suitability for the area of:	0, 1, 2, GAS Group I I (Directive 99/92/CE)	

Warning:

- Do not make any modification to the housing. Any alterations or modifications to the product will invalidate any warranties, explosion proof characteristics and any  marking.
- Install at the inlet of the housing a suitable fixing or locking device with filling material. The absence of these components will result in the loss of responsibility by the manufacturer.
- These products should only be used for the purpose they were designed for. Anything outside of the stipulated application range may be subject to unforeseen and dangerous circumstances and full responsibility will be with the installer.

3.1.6 Wiring: to connect the SPDT or DPDT contact.

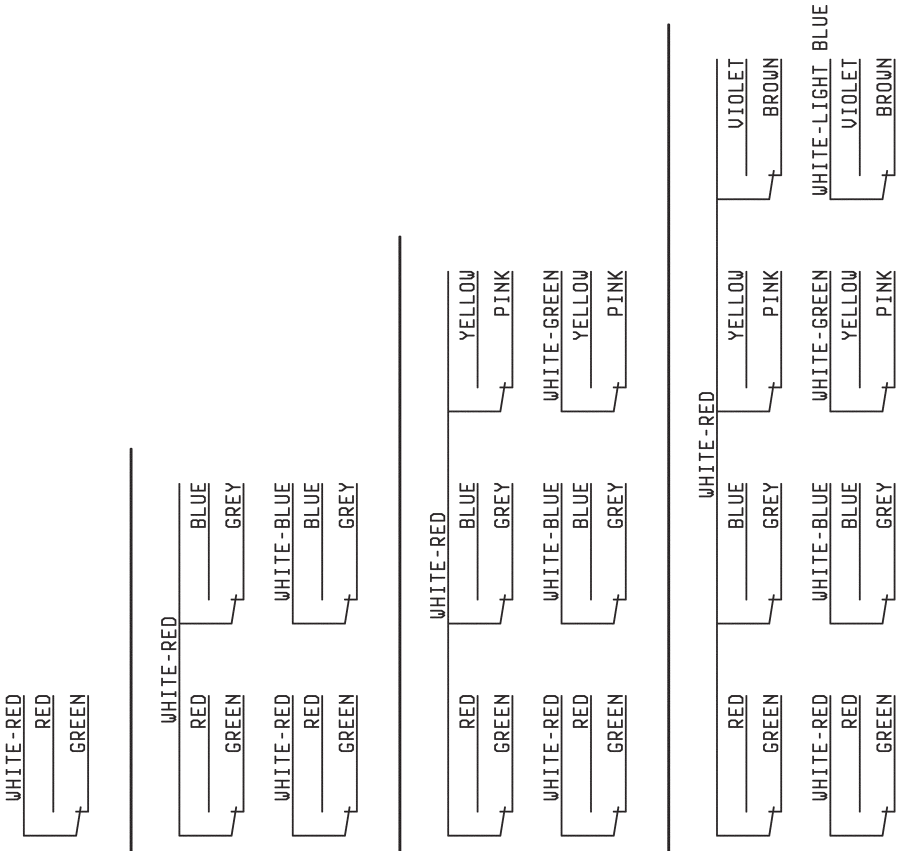

4. Contacts

Contact characteristics

Reed- Switch SPDT or SPST contact.

Also available DPDT (two SPDT simultaneous)

Switching capacity	60 VA 30 W
--------------------	------------

Switching current (I peak)	1 A
----------------------------	-----

Switching voltage	230 V ~ / 110 V =
-------------------	-------------------

4.1 Maximum number of contacts per instrument

The terminal board inside the housing can connect a maximum number of 18 cables.

Each contact has the following number of wires:

- 3 wires in SPDT contacts
- 6 wires in DPDT contacts

The various possible combinations of contacts must be taken into account - Example of how many contacts can be installed in one instrument:

- 6 SPDT
- or
- 2 SPDT + 2 DPDT
- or
- 4 SPDT + 1 DPDT etc.).

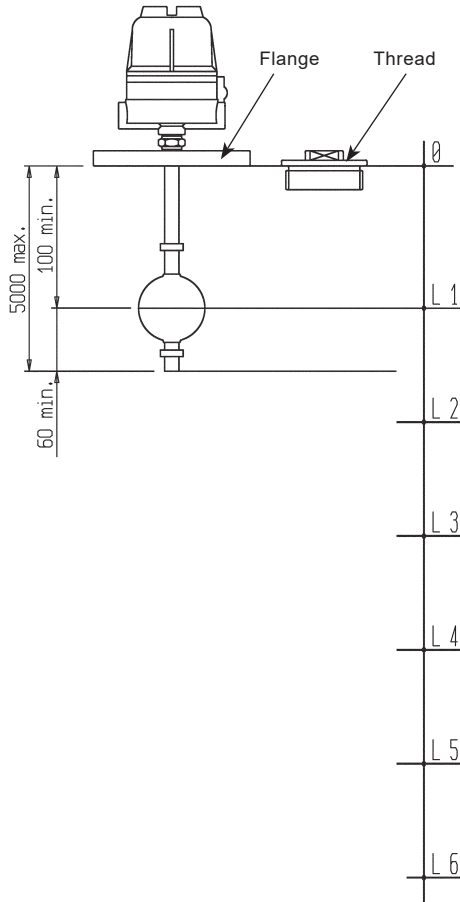

SPDT execution

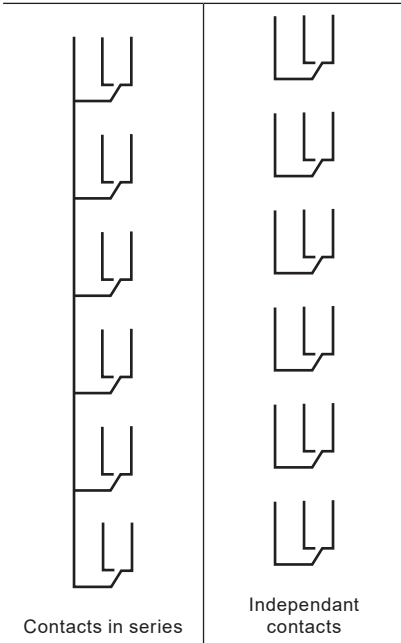

DPDT execution (two simultaneous SPDT contacts)

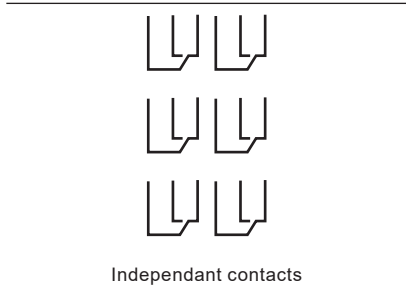

4.2 How to adjust the switching point:

1. Disconnect all of the electrical connections.
2. Remove the unit from the tank and lay it carefully on a flat surface.
3. Use a spanner to unscrew the housing screws. Open the housing.
4. Disconnect the wires from the terminal board and unscrew the metallic plate located over the terminal board, undo the rest using a spanner
5. Slowly remove the wires and fiberglass support, Caution be careful not to break the reed switch contacts.
6. Unscrew the contacts screws (1). Sliding the fiberglass support (2) move the reed switch contact to the new switching point.
7. Firmly fix the screws into the new position.
8. Re-insert fiberglass support and wires inside the tube and tighten all parts.
9. Now move the float position. Unscrew the ring screw (3 and 4). Check new switching point by moving the float up to the new position making sure to leave a gap of between 5 mm and 20 mm following the float direction (see A and B).
10. Double check the new switching position by moving the float to the switching point.
11. Connect the wires to the terminal board.
12. Close the housing.

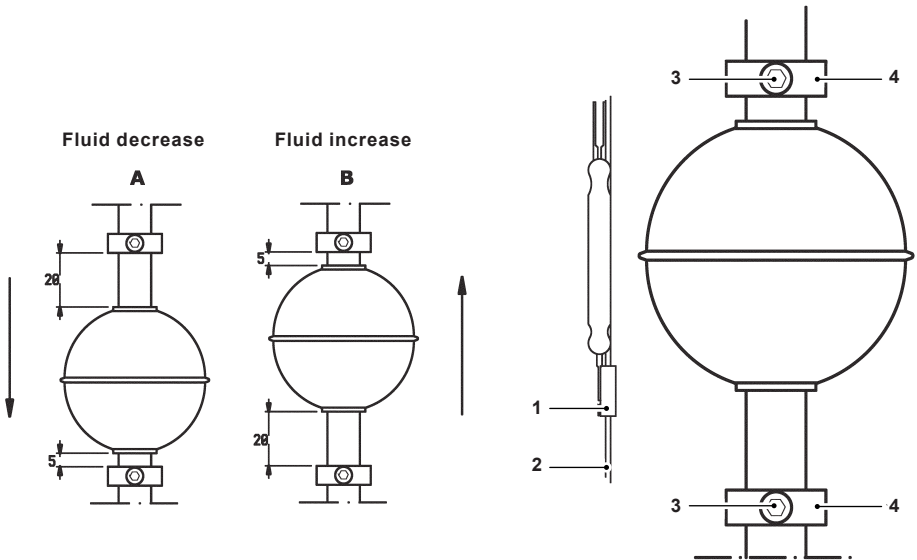

5. Transmitter

5.1 Potentiometer transmitter characteristics

A potentiometer, a device comprising a printed circuit board on which a reed/resistance chain is welded, is placed inside the float's vertical guide tube.

The total resistance of a known value is measured at the ends of this potentiometer.

The float, following the liquid level trend, activates the potentiometer's reed contact chain through its own magnetic field, locally closing the signal.

The total value of the resistance, is measured 100% at its maximum level and 0% at its minimum level. The end poles of the potentiometer are connected to a converter that transforms the input value into Ohm and the output into mA.

Reading resolution available: 5, 10, 20 mm

Resistance input $1\text{ k} \pm 100\text{ k Ohm}$.

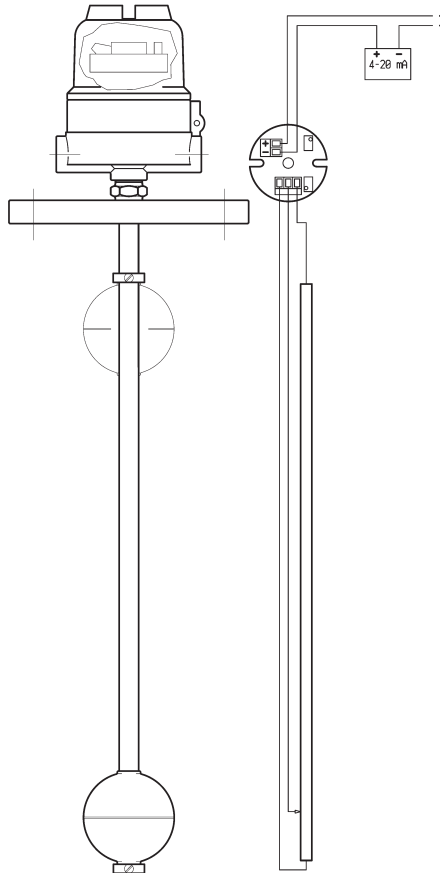

The Ohm-mA signal converters are inside the housing.

Three types of converter are available:

Converter for safe zone

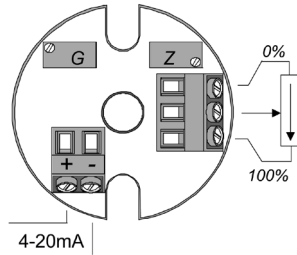

Converter for inbuilt safety zone

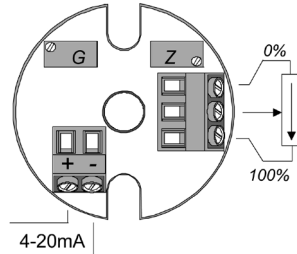

Converter suitable for HART® protocol

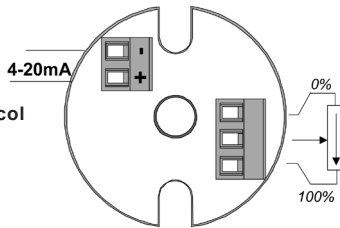

Resistance input 1 k + 100 k Ohm

Current output 4 + 20 mA

Type 1 and 2 converters can be field set using two trimmers [for the Z (zero) gauging and G (Gain) gauging], without resorting to interconnecting systems.

The type 3 converter must be regulated with an interconnection cable.

5.2 Disassembly

Before disassembly of the level switch disconnect or isolate any electricity supply or circuit and depressurize the tank.

Warning: do not disassemble the level switch before the tank has been emptied.

5.2.1 Open housing. For E Ex-d housings wait at least five minutes before open.

5.2.2 Disconnect electric circuit cables. Close housing.

5.2.3 Unscrew connection bolts.

5.2.4 Extract level switch from the tank paying attention to avoid any damage to the float.

Periodical inspections are necessary to guarantee complete efficiency of the unit. A regular maintenance programme starting from its initial installation is recommended. The suggested precautions are important to obtain the best operating conditions of the level control.

The instrument does not require preventive maintenance, however it is recommended that from time-to-time a check of the liquid fluidity is actioned to avoid any suspensions or deposits that can influence wetted parts. Also check that the float moves freely.

6. Spare parts

The available spare parts are detailed below. No other parts are supplied as spares.

Available spares

Float	6
Contact	7a
Transmitter	7b
Converter	2a

How to order spares

Always order spares by using the description given in the column headed 'Available spares' and state the size and serial number of the unit which is indicated on the name-plate:

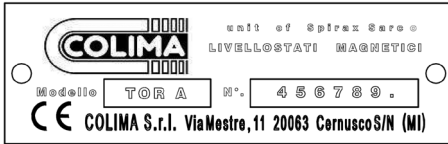

Example:

1 off Float for a Spirax Sarco Colima TOR A having DN50 flanged PN6 (AISI 304 stainless steel) connections - Serial number 456789.

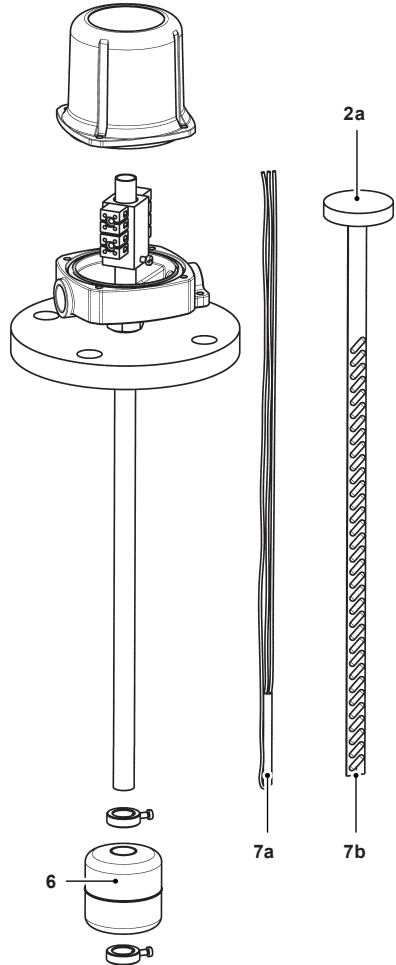

REPAIRS

Please contact your nearest Spirax Sarco Branch Office or Agent, or directly to:

Spirax-Sarco S.r.l.

Via per Cinisello, 18 - 20834 Nova Milanese (MB)

Tel.: 0362 49 17.1

Fax: 0362 49 17 307

LOSS OF GUARANTEE

Total or partial disregard of the above instructions involves loss of any rights to guarantee.

Spirax-Sarco s.r.l.

Via per Cinisello, 18 - 20834 Nova Milanese (MB)

Telefono: +39 0362 49 17.1

Fax +39 0362 49 17 307/8