

Colima MEC
Magnetic Level Switches
Installation and Maintenance Instructions

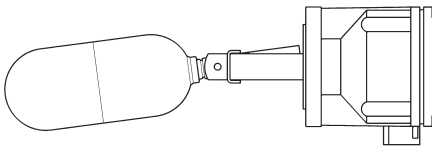

1. Safety information
2. General product information
3. Installation and maintenance
4. Spare parts

1. Safety information

Safe operation of these products can only be guaranteed if they are properly installed, commissioned, used and maintained by qualified personnel (see Section 1.11) in compliance with the operating instructions. General installation and safety instructions for pipeline and plant construction, as well as the proper use of tools and safety equipment must also be complied with.

1.1 Intended use

Referring to the Installation and Maintenance Instructions, name-plate and Technical Information Sheet, check that the product is suitable for the intended use/application. The products comply with the requirements of the European Pressure Equipment Directive 2014/68/EU falling within category 'SEP'.

It should be noted that products within this category are required by the Directive not to carry the



mark.

Products intended for use in the Naval and Marine sectors are RINA, and M.M.I (Italian navy) approved.

- i) The products have been specifically designed for use on steam, compressed air and inert industrial gases which are in Group 2 of the above mentioned Pressure Equipment Directive. The products' use on other fluids may be possible but, if this is contemplated, Spirax Sarco should be contacted to confirm the suitability of the product for the application being considered.
- ii) Check material suitability, pressure and temperature and their maximum and minimum values. If the maximum operating limits of the product are lower than those of the system in which it is being fitted, or if malfunction of the product could result in a dangerous overpressure or overtemperature occurrence, ensure a safety device is included in the system to prevent such over-limit situations.
- iii) Determine the correct installation situation and direction of fluid flow.
- iv) Spirax Sarco products are not intended to withstand external stresses that may be induced by any system to which they are fitted. It is the responsibility of the installer to consider these stresses and take adequate precautions to minimise them.
- v) Remove protection covers from all connections and protective film from all name-plates, where appropriate, before installation on steam or other high temperature applications.

1.2 Access

Ensure safe access and if necessary a safe working platform (suitably guarded) before attempting to work on the product. Arrange suitable lifting gear if required.

1.3 Lighting

Ensure adequate lighting, particularly where detailed or intricate work is required.

1.4 Hazardous liquids or gases in the pipeline

Consider what is in the pipeline or what may have been in the pipeline at some previous time. Consider: flammable materials, substances hazardous to health, extremes of temperature.

1.5 Hazardous environment around the product

Consider: explosion risk areas, lack of oxygen (e.g. tanks, pits), dangerous gases, extremes of temperature, hot surfaces, fire hazard (e.g. during welding), excessive noise, moving machinery.

1.6 The system

Consider the effect on the complete system of the work proposed. Will any proposed action (e.g. closing isolation valves, electrical isolation) put any other part of the system or any personnel at risk? Dangers might include isolation of vents or protective devices or the rendering ineffective of controls or alarms. Ensure isolation valves are turned on and off in a gradual way to avoid system shocks.

1.7 Pressure systems

Ensure that any pressure is isolated and safely vented to atmospheric pressure. Consider double isolation (double block and bleed) and the locking or labelling of closed valves. Do not assume that the system has depressurised even when the pressure gauge indicates zero.

1.8 Temperature

Allow time for temperature to normalise after isolation to avoid danger of burns and consider whether protective clothing (including safety glasses) is required.

1.9 Tools and consumables

Before starting work ensure that you have suitable tools and/or consumables available. Use only genuine Spirax Sarco replacement parts.

1.10 Protective clothing

Consider whether you and/or others in the vicinity require any protective clothing to protect against the hazards of, for example, chemicals, high/low temperature, radiation, noise, falling objects, and dangers to eyes and face.

1.11 Permits to work

All work must be carried out or be supervised by a suitably competent person. Installation and operating personnel should be trained in the correct use of the product according to the Installation and Maintenance Instructions. Where a formal 'permit to work' system is in force it must be complied with. Where there is no such system, it is recommended that a responsible person should know what work is going on and, where necessary, arrange to have an assistant whose primary responsibility is safety. Post 'warning notices' if necessary.

1.12 Handling

Manual handling of large and/or heavy products may present a risk of injury. Lifting, pushing, pulling, carrying or supporting a load by bodily force can cause injury particularly to the back. You are advised to assess the risks taking into account the task, the individual, the load and the working environment and use the appropriate handling method depending on the circumstances of the work being done.

1.13 Residual hazards

In normal use the external surface of the product may be very hot. If used at the maximum permitted operating conditions the surface temperature of some products may reach temperatures of 350 °C. Many products are not self-draining. Take due care when dismantling or removing the product from an installation (refer to 'Maintenance instructions').

1.14 Freezing

Provision must be made to protect products which are not self-draining against frost damage in environments where they may be exposed to temperatures below freezing point.

1.15 Disposal

This product is recyclable. No ecological hazard is anticipated with the disposal of this product providing due care is taken.

Please visit the Spirax Sarco product compliance web pages

<https://www.spiraxsarco.com/product-compliance>

for up to date information on any substances of concern that may be contained within this product.

Where no additional information is provided on the Spirax Sarco product compliance web page, this product may be safely recycled and/or disposed providing due care is taken. Always check your local recycling and disposal regulations.

1.16 Returning products

Customers and stockists are reminded that under EC Health, Safety and Environment Law, when returning products to Spirax Sarco they must provide information on any hazards and the precautions to be taken due to contamination residues or mechanical damage which may present a health, safety or environmental risk. This information must be provided in writing including Health and Safety data sheets relating to any substances identified as hazardous or potentially hazardous.

2. General product information

2.1 Description

The Colima MEC magnetic-activated level switch is designed to control the liquid levels in most industrial applications. When installed at the foreseen point of operation, they work as ON/OFF switches for full automatic management of tanks (including pressurised ones) allowing operations such as starting/stopping of pumps, opening/closing of solenoid valves and activation of alarm systems.

One or more units can be used, depending on the number of operation points required.

Mounting

Colima MEC magnetic level switch is side mounted directly in the tank. It can also be installed horizontally or vertically directly in the tank, or externally in a special chamber outside the tank. A square flange is specific for the naval industry.

Standards and certification

The Colima MEC magnetic level switch complies with the following European Directives:

- ATEX 94 / 9 / EC
- European Pressure Equipment Directive 2014/68/EU
- Products intended for use in the Naval and Marine sectors are RINA, and M.M.I (Italian navy) approved.

2.2 Operation

The level switch is secured to the tank by means of a flange. This supports a float with a pre-set pivoting axis. The float is integral with a sealed cartridge that contains a magnet.

Two oscillating magnets on the same axis, one integral with the float and one integral with the electrical equipment, repel each other reciprocally through a non-magnetic material flange.

The flange separates the housing, containing the electrical equipment, from the float that is inserted in the tank.

The float automatically follows the level of the liquid, both in rising and in falling conditions.

The switching of the electrical contact is quick and reliable.

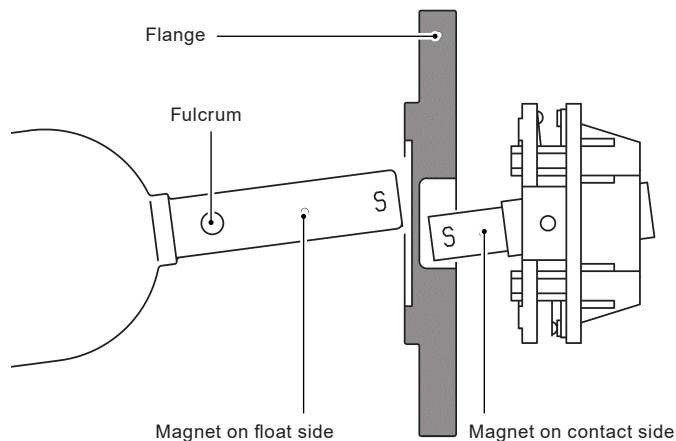

2.3 Materials

No.	Part	Material
1	Housing	Aluminium Rilsan coated / Stainless steel
2	Contact	SPDT / DPDT
3	Flange	304 / 316L / PVC / PP / PVDF Lowest applicable nominal diameter 50 (2") with nominal pressure related to design needs.
4	Float	04 / 316L / Monel / Hastelloy / PVC / PP / PVDF
5	Chamber (not shown)	A105 / 304 / 316L

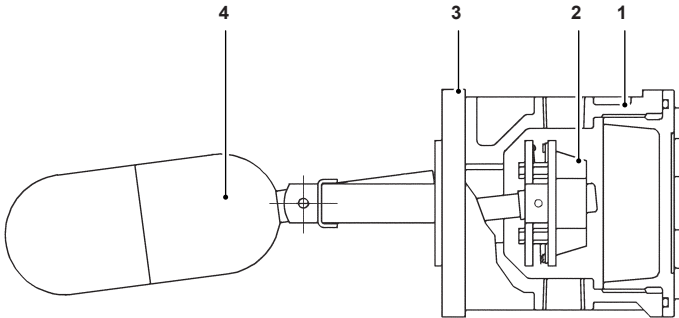

2.4 Design conditions

		Steel	_____	-20 °C to +150 °C
			with cooling extension	-20 °C to +350 °C
TMA	Maximum allowable temperature	Plastic	PVC	-20 °C to +70 °C
			PP	-20 °C to +105 °C
			PVDF	-20 °C to +130 °C
PMA	Maximum allowable pressure	Steel	Colima's flange	< 16 bar g
			flange sized according to rating	< 100 bar g
		Plastic		6 bar g
Fluid specific gravity				≥ 0.8 kg / l
			only CP type	≥ 0.5 kg / l
Differential				fixed 15 mm
			only D and DV types	± 40 °

Materials and sizing are defined in relation to the characteristics of the liquid and the project conditions.

Models:

MEC A



Standard type for general purpose, used in most industrial applications.
Horizontal mounting.
One operation point.
In the picture, the 100% stainless steel versions are suitable for low temperatures, for installation in high saline concentration environments and for use in the food industry.

MEC AT



Type with cooling extension, to be used in applications with temperatures from 150 °C to 350 °C.
It can also be assembled in types D, DV, L and S.
Horizontal or vertical mounting.
One operation point.

MEC CP

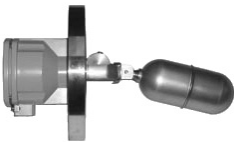

Type suitable for controlling liquid with specific gravity ≥ 0.5 kg / l.
Horizontal mounting.
Float with counterweight.
One operation point.

MEC D



Type with differential range, adjustable $\pm 40^\circ$ in two directions.
Can be used as a start / stop with a single instrument.
Horizontal mounting.
The differential increases depending on the length of the stem and there are 7 regulation points, every 15° .

MEC DV



Type with differential range, adjustable in one direction, only 0 - 40 °.
Can be used as a start / stop with a single instrument.
Vertical mounting.
The differential increases depending on the length of the stem and there are 4 regulation points, every 15 °.

MEC AV



Specific type for high vibration with reed switch contact.
Frequencies 5 - 100 Hz.
Horizontal mounting.
One operation point.

MEC M



Type equipped with protection bellow to avoid any deposits or inclusions present in the process liquid, eliminating risk of blockage.
It can also be mounted on types D, DV, L and S.
Horizontal mounting.
One operation point.
Stem length depending upon application.

MEC O



Type indicated for sunken or difficult to access tanks (high or low level). Vertical mounting on pole in open tanks or in tanks with a manhole.
Attention must be paid to the connection rating: float is 120 mm.
One operation point, with field adjustable start / stop function.
Stem length depending upon application.

MEC PN



Pneumatic type, suitable in applications where there is no electrical supply.
Stainless steel body with three way valve.
Horizontal or vertical mounting.
One operation point.

MEC L



Type recommended in applications containing foam, inclusions and viscous fluids, where conditions require that the fulcrum point is not in touch with the process liquid.
Vertical mounting.
One operation point.
Stem length depending upon application.

MEC S



Type recommended in applications containing foam, inclusions and viscous fluids, where conditions require that the fulcrum point is not in touch with the process liquid.
Horizontal mounting.
One operation point.
Stem length depending upon application.

MEC T



Type equipped with a device for field verification (operation checking).
Mostly used in the naval industry.
Can also be made in types L and S.
Horizontal and vertical mounting.
One operation point.

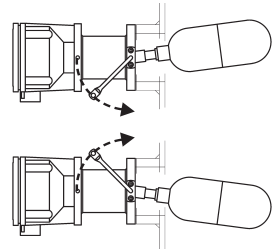

Example of manual operation checking, to be carried out in the field.

MEC MINI



Small dimension type.
Horizontal or vertical mounting.
One operation point.
IP54 and IP67 protection degree.

3. Installation and maintenance

Note: Before actioning any installation or maintenance work observe the 'Safety information' in Section 1.

Referring to the Installation and Maintenance Instructions, name-plate and Technical Information Sheet, check that the product is suitable for the intended installation.

Check: materials, pressure and temperature to ensure compatibility of the product with the required application.

Remove protective covers from all connections and the protective film from the name-plate.

3.1 Assembly

The Colima MEC magnetic level switches are delivered packed.

Caution before installation disassemble the lower flange and remove the float from its package + **Confirm** the presence of supplied gaskets.

3.1.1 Fit the level switch in the tank paying attention to avoid any damage at float. Any damage of the float can interfere with the correct operation of the unit.

3.1.2 Place the supplied gasket between the flanges.

3.1.3 Fix the flanges with bolts. Firmly secure the fixing by tightening the flange bolts.

3.1.4 Ensure that there is nothing stopping the correct operation of the float.

3.1.5 Open the unit housing and connect the wiring at the terminal board. The housing has two cable entry points: G ½" F, Explosion-proof Gk ½" F, ½" NPT F, M20 x 1.5, PG 13.5

Caution: Always ensure that correct earthing of the equipment is carried out. Specific points are set inside and outside the housing.

Explosion-proof housing operating limits

Technical data Class I: simple protective-earth connection requirements

Employment data for potentially explosive atmospheres

Ambient temperature limits	-20 + 50 °C	
Marking	Ex II 1/2 G EEx d II C, T5 resp. T4	
Temperature class	T5	T4
Permitted temperature variation range	-20 °C to +76 °C	-20 °C to +104 °C
Suitability for area of: 0, 1, 2, GAS Group I I (Directive 99/92/CE)		

Warning:

1. Do not make any modification to the housing. Any alterations or modifications to the product will invalidate any warranties, explosion proof characteristics and any  marking.
2. Install at the inlet of the housing a suitable fixing or locking device with filling material. The absence of these components will result in the loss of responsibility of the manufacturer.
3. These products should only be used for what they are designed for. Anything outside of the stipulated application range may be subject to unforeseen and dangerous circumstances and full responsibility will be with the installer.

3.1.6 Wiring: to connect SPDT or DPDT standard contact.

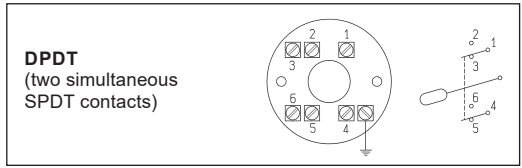
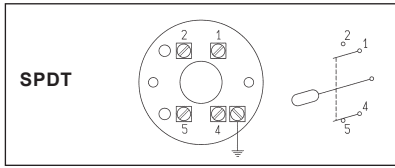

Electrical contact characteristics

Standard

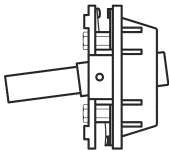

Standard microswitch recommended for general purpose. Goldplated contacts in open air. Contact coating:

Galvanic in gold	Standard 2 μ
	Special 5 μ

V	~ A =		Load
220	3	2	Resistive
	1.5	0.5	Inductive
30	6	3	Resistive
	3	1.5	Inductive

Weather-proof

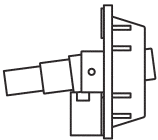

Weather-proof microswitch. Goldplated contacts. IP66

Nominal current	Minimum 10 mA
	Maximum 400 mA
Nominal voltage	Minimum 5 V
	Maximum 30 V

V	~ A =		Load
220	7	0.5	Resistive
	5	0.03	Inductive
30	7	7	Resistive
	5	5	Inductive

For oxidising environments

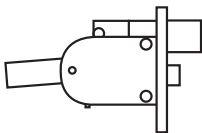

Microswitch indicated for oxidising or corrosive environments. Goldplated contacts hermetically sealed in inert gas.

V	~ A =		Load
220	1	-	Resistive
	-	0.4	Inductive
30	3	-	Resistive
	-	1.5	Inductive

For high vibrations

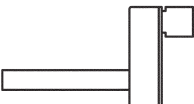

Reed switch contact indicated for high vibrations, resists from 5 to 100 Hz. 30 g 11 ms. Goldplated contacts hermetically sealed in inert gas.

Interruption power	60 W/ VA
Switchable current	1 A
Switchable voltage	250 V \cong

3.2 Disassembly

Before disassembly of the level switch disconnect or isolate any electricity supply or circuit and depressurise the tank.

Warning: do not disassemble the level switch before the tank has been emptied.

3.2.1 Open housing. For E Ex-d housings wait at least five minutes before opening.

3.2.2 Disconnect the electric circuit cables. Close the housing.

3.2.3 Unscrew the connection bolts.

3.2.4 Extract the level switch from the tank paying attention to avoid any damage to the float.

Periodical inspections are necessary to guarantee complete efficiency of the unit. A regular maintenance programme starting from its initial installation is recommended. The suggested precautions are important to obtain the best operating conditions of the level control.

The instrument does not require preventive maintenance, however it is recommended that from time-to-time a check of the liquid fluidity is actioned to avoid any suspensions or deposits that can influence wetted parts. Also check that the float moves freely.

Mounting accessories

Counterflanges

(Other sizes are available on request)

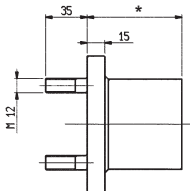
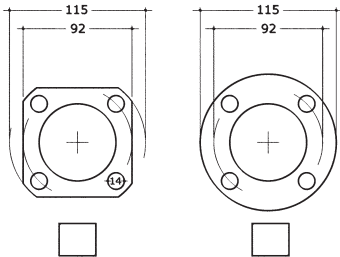

Dimensions

*

All types
80 mm

D and DV only
35 mm

Chamber for installation outside the tank

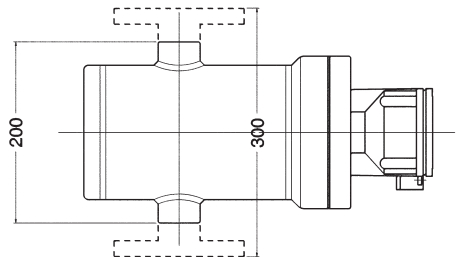

Minimum distance between connections

Flange
300 mm

Output
200 mm

4. Spare parts

The available spare parts are detailed below. No other parts are supplied as spares.

Available spares

Contact	2
Float	4

How to order spares

Always order spares by using the description given in the column headed 'Available spares' and state the size and serial number of the unit which is indicated on the name-plate:

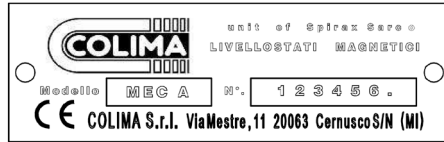

Example: 1 off Float for a Spirax Sarco Colima MEC A having DN50 flanged ASME 150 RF connections - Serial number 123456.

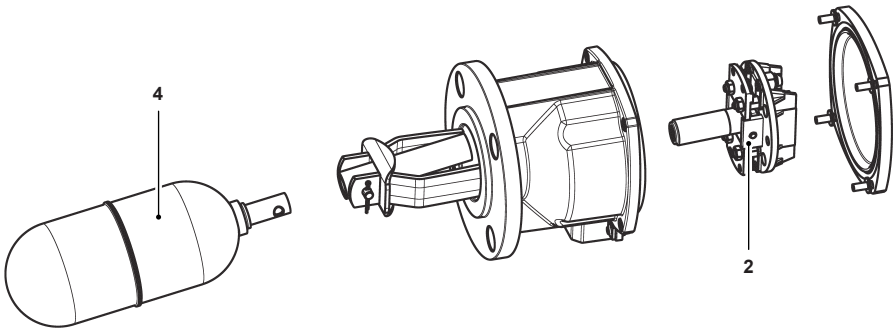

REPAIRS

Please contact our nearest Branch Office or Agent,
or directly

Spirax-Sarco S.r.l.

Via per Cinisello, 18 - 20834 Nova Milanese (MB) - ITALY

Tel.: +39 0362 49 17.1

Fax: +39 0362 49 17 307

LOSS OF GUARANTEE

Total or partial disregard of above instructions involves loss of any rights to guarantee.

Spirax-Sarco s.r.l.

Via per Cinisello, 18 - 20834 Nova Milanese (MB)

Tel.: +39 0362 49 17.1

Fax +39 0362 49 17 307