

**BT6HC Hygienic Sanitary  
Balanced Pressure Steam Trap  
for High Capacity and CIP/SIP Applications**  
Installation and Maintenance Instructions

---

---

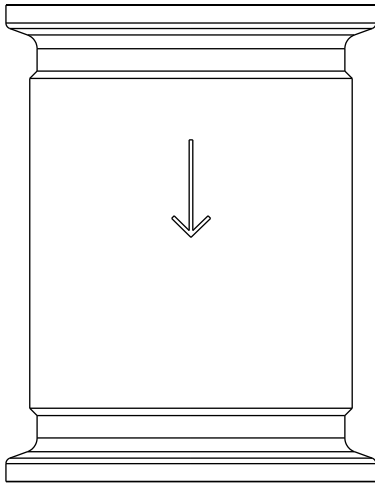

1. Safety information
2. General product information
3. Installation
4. Commissioning
5. Operation
6. Spare parts and maintenance



# 1. Safety information

Safe operation of this product can only be guaranteed if it is properly installed, commissioned, used and maintained by qualified personnel (see Section 1.11) in compliance with the operating instructions. General installation and safety instructions for pipeline and plant construction, as well as the proper use of tools and safety equipment must also be complied with.

## 1.1 Intended use

Referring to the Installation and Maintenance Instructions, name-plate and Technical Information Sheet, check that the product is suitable for the intended use/application.

This product complies with the requirements of the European Pressure Equipment Directive 2014/68/EU and carries the  mark when so required.

The product falls within the following Pressure Equipment Directive categories:

Product	Group 2 Gases	Group 2 Liquids
BT6HC	SEP	SEP

- i) This product has been specifically designed for use on steam, air or condensate / water, which is in Group 2 of the above mentioned Pressure Equipment Directive. The products' use on other fluids may be possible but, if this is contemplated, Spirax Sarco should be contacted to confirm the suitability of the product for the application being considered.
- ii) Check material suitability, pressure and temperature and their maximum and minimum values. If the maximum operating limits of the product are lower than those of the system in which it is being fitted, or if malfunction of the product could result in a dangerous overpressure or overtemperature occurrence, ensure a safety device is included in the system to prevent such over-limit situations.
- iii) Determine the correct installation situation and direction of fluid flow.
- iv) Spirax Sarco products are not intended to withstand external stresses that may be induced by any system to which they are fitted. It is the responsibility of the installer to consider these stresses and take adequate precautions to minimise them.
- v) Remove protection covers from all connections and protective film from all name-plates, where appropriate, before installation on steam or other high temperature applications.

## 1.2 Access

Ensure safe access and if necessary a safe working platform (suitably guarded) before attempting to work on the product. Arrange suitable lifting gear if required.

## 1.3 Lighting

Ensure adequate lighting, particularly where detailed or intricate work is required.

## 1.4 Hazardous liquids or gases in the pipeline

Consider what is in the pipeline or what may have been in the pipeline at some previous time. Consider: flammable materials, substances hazardous to health, extremes of temperature.

## 1.5 Hazardous environment around the product

Consider: explosion risk areas, lack of oxygen (e.g. tanks, pits), dangerous gases, extremes of temperature, hot surfaces, fire hazard (e.g. during welding), excessive noise, moving machinery.

## 1.6 The system

Consider the effect on the complete system of the work proposed. Will any proposed action (e.g. closing isolation valves, electrical isolation) put any other part of the system or any personnel at risk? Dangers might include isolation of vents or protective devices or the rendering ineffective of controls or alarms. Ensure isolation valves are turned on and off in a gradual way to avoid system shocks.

## 1.7 Pressure systems

Ensure that any pressure is isolated and safely vented to atmospheric pressure. Consider double isolation (double block and bleed) and the locking or labelling of closed valves. Do not assume that the system has depressurised even when the pressure gauge indicates zero.

## 1.8 Temperature

Allow time for temperature to normalise after isolation to avoid danger of burns.

## 1.9 Tools and consumables

Before starting work ensure that you have suitable tools and /or consumables available. Use only genuine Spirax Sarco replacement parts.

## 1.10 Protective clothing

Consider whether you and /or others in the vicinity require any protective clothing to protect against the hazards of, for example, chemicals, high/low temperature, radiation, noise, falling objects, and dangers to eyes and face.

## 1.11 Permits to work

All work must be carried out or be supervised by a suitably competent person. Installation and operating personnel should be trained in the correct use of the product according to the Installation and Maintenance Instructions. Where a formal 'permit to work' system is in force it must be complied with. Where there is no such system, it is recommended that a responsible person should know what work is going on and, where necessary, arrange to have an assistant whose primary responsibility is safety. Post 'warning notices' if necessary.

## 1.12 Handling

Manual handling of large and/or heavy products may present a risk of injury. Lifting, pushing, pulling, carrying or supporting a load by bodily force can cause injury particularly to the back. You are advised to assess the risks taking into account the task, the individual, the load and the working environment and use the appropriate handling method depending on the circumstances of the work being done.

## 1.13 Residual hazards

In normal use the external surface of the product may be very hot. If used at the maximum permitted operating conditions the surface temperature of some products may reach temperatures of 300 °C (572 °F).

Many products are not self-draining. Take due care when dismantling or removing the product from an installation (refer to 'Maintenance instructions').

## 1.14 Freezing

Provision must be made to protect products which are not self-draining against frost damage in environments where they may be exposed to temperatures below freezing point.

## 1.15 Disposal

Unless otherwise stated in the Installation and Maintenance Instructions, this product is recyclable and no ecological hazard is anticipated with its disposal providing due care is taken.

Please visit the Spirax Sarco product compliance web pages

<https://www.spiraxsarco.com/product-compliance>

for up to date information on any substances of concern that may be contained within this product. Where no additional information is provided on the Spirax Sarco product compliance web page, this product may be safely recycled and/or disposed providing due care is taken. Always check your local recycling and disposal regulations.

## 1.16 Returning products

Customers and stockists are reminded that under EC Health, Safety and Environment Law, when returning products to Spirax Sarco they must provide information on any hazards and the precautions to be taken due to contamination residues or mechanical damage which may present a health, safety or environmental risk. This information must be provided in writing including Health and Safety data sheets relating to any substances identified as hazardous or potentially hazardous.

## 2. General product information

### 2.1 General description

The Spirax Sarco BT6HC is a high capacity thermostatic steam trap designed to remove condensate from hygienic and sanitary steam systems with minimal backing up. Applications include sterile steam barriers, process vessels and CIP/SIP systems. Manufactured in 316L stainless steel with a crevice free body, it is self-draining and operates close to steam temperature. Traps are individually packaged with protective end caps and sealed in a polythene bag.

#### Surface finish

All internal wetted surfaces have a finish of 0.8 µm (32 micro-inch Ra). External surfaces (excluding the clamp) have a surface finish of 1.2 µm (47 micro inch Ra). Surface finish of 0.4 µm (16 micro-inch Ra) can be supplied on request by electro-polishing.

#### Options

Electro-polishing of internal surfaces to 0.4 µm (16 micro-inch RA).  
Special connections to suit most piping systems.

#### Standards

The BT6HC fully complies with the ASME BPE, where applicable. It also complies with the requirements of the European Pressure Equipment Directive 2014/68/EU.  
All wetted parts of this trap are manufactured from FDA/3-A approved materials.

#### Certification

The product is available with material certification to EN 10204 3.1 for the body if requested at the time of order placement.

**Note:** For further information see the following Technical Information Sheet, TI-P180-13.

## 2.2 Sizes and pipe connections

Suitable for installation using a 1" or 1½" sanitary clamp compatible hygienic connections.

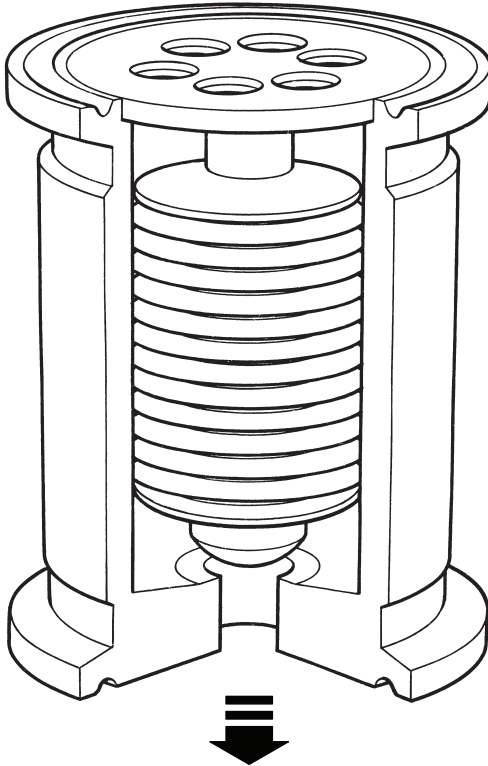
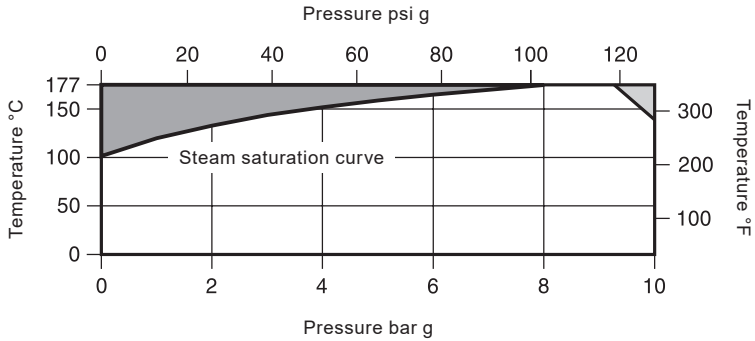



Fig. 1 BT6HC

## 2.3 Pressure / temperature limits



 The product **must not** be used in this region.

 The product should not be used in this region as damage to the internals may occur.

**Note:** For hygienic/sanitary clamp ends the maximum pressure/temperature may be restricted by the gasket or sanitary clamp used. Please consult Spirax Sarco.

Body design conditions			PN10
PMA	Maximum allowable pressure	10 bar g @ 140 °C	(145 psi g @ 284 °F)
TMA	Maximum allowable temperature	177 °C @ 9.2 bar g	(350 °F @ 133 psi g)
	Minimum allowable temperature	-254 °C	(-425 °F)
PMO	Maximum operating pressure for saturated steam service	6 bar g	(87 psi g)
TMO	Maximum operating temperature	165 °C @ 6 bar g	(329 °F @ 87 psi g)
	Minimum operating temperature	0 °C	(32 °F)
	Designed for a maximum cold hydraulic test pressure of:	15 bar g	(218 psi g)



# 3. Installation

**Note:** Before actioning any installation observe the 'Safety information' in Section 1.

Referring to the Installation and Maintenance Instructions, name-plate and Technical Information Sheet, check that the product is suitable for the intended installation:

**3.1** Check materials, pressure and temperature and their maximum values. If the maximum operating limit of the product is lower than that of the system in which it is being fitted, ensure that a safety device is included in the system to prevent overpressurisation.

**3.2** Determine the correct installation situation and the direction of fluid flow.

**3.3** All packaging and protective covers are to be removed from the trap and its connections, including the internal element support prior to installation.

**3.4** The trap is designed to be installed in **vertical lines** with the flow downwards so that it can be completely self-draining. Check the flow direction arrow on the body for the correct orientation. Sanitary clamp fittings and gaskets are to be supplied by the installer. Do not expose the element to superheat conditions as over expansion may result. This may occur if the trap is removed before it is cool or if fast acting isolation valves depressurise the pipework.

**Note:** The BT6HC must be allowed to cool to ambient temperature, prior to CIP operation.

**3.5** Installation in horizontal pipes will not allow self-draining and may cause wear on the seat/valve.

**3.6** **General considerations:** The body and element must be handled carefully to ensure that the machined surfaces are not damaged. Care must be taken not to puncture the element or expose it to temperatures in excess of 177 °C (350 °F). Dispose of the sealed element in a safe manner.

**Note:** If the trap is to discharge to atmosphere ensure it is to a safe place, the discharging fluid may be at a temperature of 100 °C (212 °F).

## 4. Commissioning

After installation or maintenance ensure that the system is fully functioning. Carry out tests on any alarms or protective devices.

## 5. Operation

The operating element is a capsule containing a small quantity of a special liquid with a boiling point below that of water. In the cold conditions that exist at start-up, the capsule is relaxed. The valve is off its seat and is wide open, allowing unrestricted removal of air. This is a feature of all balanced pressure traps and explains why they are well suited to air venting.

As condensate passes through the balanced pressure steam trap, heat is transferred to the liquid in the capsule. The fill liquid boils before steam reaches the trap. The vapour pressure within the capsule causes it to expand and the trap shuts. Heat loss from the trap then cools the water surrounding the capsule, the fill condenses and the capsule contracts, opening the valve and releasing condensate until steam temperature approaches again at which the cycle is repeated. During CIP operations the trap will be fully open to allow maximum flow of the cleaning fluid. On steam start-up the trap will remain open until all air and incondensibles are purged from the system.

Under normal operating conditions the operation of the trap will depend on the steam pressure, capacity and location.

Typically the trap will begin to open at approximately 3 °C (5.4 °F) below steam saturation temperature at the trap inlet.

# 6. Spare parts and maintenance

**Note:** Before actioning any maintenance observe the 'Safety information' in Section 1.

## 6.1 Spare parts

The available spare parts are detailed below:

### Available spare

Element assembly	2
------------------	---

### How to order spares

Always order spares by using the description given in the column headed 'Available spare' and state the size, model number and pressure rating of the trap.

**Example:** 1 - Element assembly for a Spirax Sarco 1" BT6HC balanced pressure steam trap.

## 6.2 How to replace the element assembly:

- Before undertaking any maintenance on the trap it must be isolated from both supply line and return line and any pressure allowed to safely normalise to atmosphere. The trap should then be allowed to cool.
- Undo the sanitary clamp fittings and remove the trap from the pipeline.
- Remove the element assembly and replace with a new one.
- Replace the trap in the pipeline together with the required gaskets and retighten the sanitary clamp fittings to the manufacturers' specified torque.

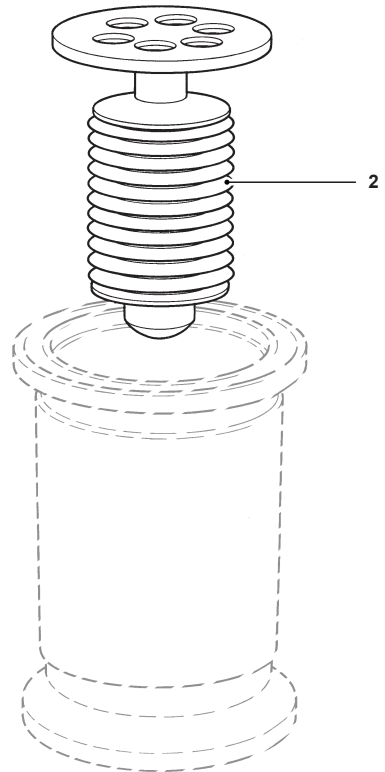

Fig. 2

