

---

## BSP and NPT

# Pressure Gauges with Syphon and Cock

### Installation and Maintenance Instructions

---

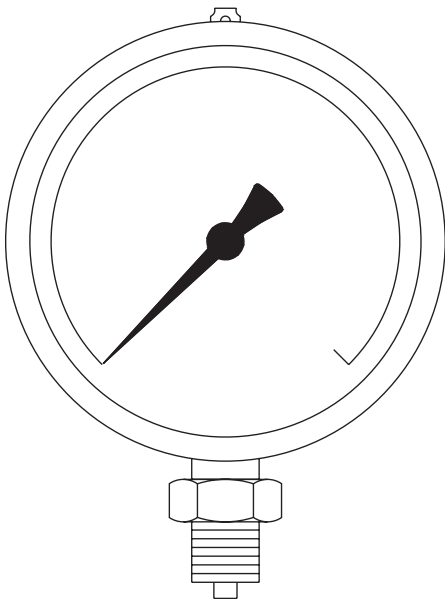

1. Safety information
2. General product information
3. Installation
4. Commissioning
5. Operation
6. Maintenance
7. Spare parts



# 1. Safety information

Safe operation of these products can only be guaranteed if they are properly installed, commissioned, used and maintained by qualified personnel (see Section 1.11) in compliance with the operating instructions. General installation and safety instructions for pipeline and plant construction, as well as the proper use of tools and safety equipment must also be complied with.

## 1.1 Intended use

Referring to the Installation and Maintenance Instructions, product marking and Technical Information Sheet, check that the product is suitable for the intended use/application. The products comply with the requirements of the 'EU Pressure Equipment Directive/UK Pressure Equipment (Safety) Regulations' and fall within the category 'SEP'.

Please note that products within this category are required by the Directive not to carry the

 mark.

Product	Group 1 Gases	Group 2 Gases	Group 1 Liquids	Group 2 Liquids
BSP and NPT pressure gauges with syphons and cocks	-	SEP	-	SEP

- i) These products have been specifically designed for use on steam, air or water/condensate which are in Group 2 of the above mentioned Pressure Equipment Directive. The products' use on other fluids may be possible but, if this is contemplated, Spirax Sarco should be contacted to confirm the suitability of the product for the application being considered.
- ii) Check material suitability, pressure and temperature and their maximum and minimum values. If the maximum operating limits of the product are lower than those of the system in which it is being fitted, or if malfunction of the product could result in a dangerous overpressure or overtemperature occurrence, ensure a safety device is included in the system to prevent such over-limit situations.
- iii) Determine the correct installation situation and direction of fluid flow.
- iv) Spirax Sarco products are not intended to withstand external stresses that may be induced by any system to which they are fitted. It is the responsibility of the installer to consider these stresses and take adequate precautions to minimise them.
- v) Remove protection covers from all connections before installation.

## 1.2 Access

Ensure safe access and if necessary a safe working platform (suitably guarded) before attempting to work on the product. Arrange suitable lifting gear if required.

## 1.3 Lighting

Ensure adequate lighting, particularly where detailed or intricate work is required.

## 1.4 Hazardous liquids or gases in the pipeline

Consider what is in the pipeline or what may have been in the pipeline at some previous time. Consider: flammable materials, substances hazardous to health, extremes of temperature.

## 1.5 Hazardous environment around the product

Consider: explosion risk areas, lack of oxygen (e.g. tanks, pits), dangerous gases, extremes of temperature, hot surfaces, fire hazard (e.g. during welding), excessive noise, moving machinery.

## 1.6 The system

Consider the effect on the complete system of the work proposed. Will any proposed action (e.g. closing isolation valves, electrical isolation) put any other part of the system or any personnel at risk?

Dangers might include isolation of vents or protective devices or the rendering ineffective of controls or alarms. Ensure isolation valves are turned on and off in a gradual way to avoid system shocks.

## 1.7 Pressure systems

Ensure that any pressure is isolated and safely vented to atmospheric pressure. Consider double isolation (double block and bleed) and the locking or labelling of closed valves. Do not assume that the system has depressurised even when the pressure gauge indicates zero.

## 1.8 Temperature

Allow time for temperature to normalise after isolation to avoid danger of burns.

## 1.9 Tools and consumables

Before starting work ensure that you have suitable tools and/or consumables available. Use only genuine Spirax Sarco replacement parts.

## 1.10 Protective clothing

Consider whether you and/or others in the vicinity require any protective clothing to protect against the hazards of, for example, chemicals, high/low temperature, radiation, noise, falling objects, and dangers to eyes and face.

## 1.11 Permits to work

All work must be carried out or be supervised by a suitably competent person.

Installation and operating personnel should be trained in the correct use of the product according to the Installation and Maintenance Instructions.

Where a formal 'permit to work' system is in force it must be complied with. Where there is no such system, it is recommended that a responsible person should know what work is going on and, where necessary, arrange to have an assistant whose primary responsibility is safety.

Post 'warning notices' if necessary.

## 1.12 Handling

Manual handling of large and/or heavy products may present a risk of injury. Lifting, pushing, pulling, carrying or supporting a load by bodily force can cause injury particularly to the back. You are advised to assess the risks taking into account the task, the individual, the load and the working environment and use the appropriate handling method depending on the circumstances of the work being done.

### 1.13 Residual hazards

In normal use the external surface of the product may be very hot. If used at the maximum permitted operating conditions the surface temperature of some products may reach temperatures of 200 °C (392 °F).

Many products are not self-draining. Take due care when dismantling or removing the product from an installation (refer to 'Maintenance instructions').

### 1.14 Freezing

Provision must be made to protect products which are not self-draining against frost damage in environments where they may be exposed to temperatures below freezing point.

### 1.15 Disposal

Unless otherwise stated in the Installation and Maintenance Instructions, this product is recyclable and no ecological hazard is anticipated with its disposal providing due care is taken with the exception of PTFE (ball valves).

#### PTFE:

- Can only be disposed of by approved methods, not incineration.
- Keep PTFE waste in a separate container, do not mix it with other rubbish, and consign it to a landfill site.

### 1.16 Returning products

Customers and stockists are reminded that under EC Health, Safety and Environment Law, when returning products to Spirax Sarco they must provide information on any hazards and the precautions to be taken due to contamination residues or mechanical damage which may present a health, safety or environmental risk. This information must be provided in writing including Health and Safety data sheets relating to any substances identified as hazardous or potentially hazardous.

## 2. General product information

### 2.1 General description

These pressure gauges have 100 mm (4") diameter dials with units marked in bar, psi and inches Hg for vacuum as appropriate. The gauge is supplied with either:-  
Ring-type syphon tube and cock or a 'U' type syphon tube and cock.

The Bourdon tube gauge is constructed in accordance with:

- DIN EN 837-1:1997-02 Pressure gauges - Part 1: Bourdon tube pressure gauges; dimensions, metrology, requirements and testing,  
and
- DIN EN 837-1:1997-02 Pressure gauges - Part 3: Diaphragm and capsule pressure gauges; dimensions, metrology, requirements and testing

#### Note:

For further information see the following Technical Information Sheets: TI-P027-01 (BSP), TI-P027-03 (NPT), which give full details.

### 2.2 Sizes and pipe connections

		BSP	NPT
<b>Pressure gauge:</b>		3/8" male	1/2" male
	Gauge end	3/8" female	1/2" female
<b>Gauge cock:</b>	Syphon end	3/8" female parallel	1/2" female
	Cock end	3/8" male taper	1/2" male
<b>Ring/'U' syphon:</b>	Process end	3/8" male parallel	1/2" male

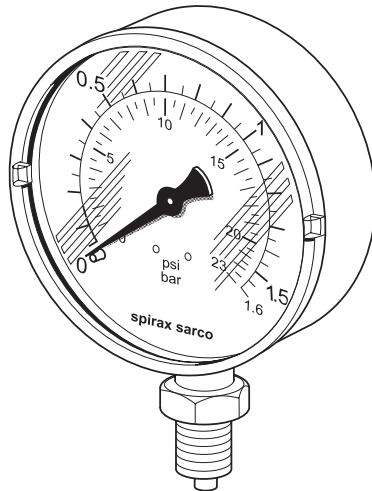

Fig. 1

## 2.3 Pressure/temperature limits and available range

		BSP	NPT	
Maximum design conditions		Full scale reading	Full scale reading	
PMA	Maximum allowable pressure	Full scale reading	Full scale reading	
TMA	Maximum allowable temperature of gauge	217 °C	422.6 °F	
<b>Note:</b> Either a 'U' or a ring syphon must be fitted to achieve this.				
Minimum allowable temperature		-40 °C	-40 °F	
* PMO Maximum operating pressure	Steel	Range	0 to 1.6 bar	0 to 30 psi
		Range	0 to 4 bar	0 to 60 psi
		Range	0 to 6 bar	0 to 100 psi
		Range	0 to 10 bar	0 to 160 psi
		Range	0 to 16 bar	0 to 300 psi
		Range	0 to 25 bar	0 to 360 psi
	These are available as compound gauges down to full vacuum	Range	-1 to 1.5 bar	30" Hg to 20 psi
		Range	-1 to 3 bar	30" Hg to 40 psi
		Range	-1 to 5 bar	30" Hg to 70 psi
		Range	0 to 4 bar	
		Range	0 to 10 bar	
		Range	0 to 16 bar	
Range	0 to 25 bar			
Maximum ambient temperature		50 °C	140 °F	

**\* Please note:**

For compressed air and steam services the PMO (Maximum operating pressure) for this product is 16 bar g (232.06 psi g). Gauge cock limited to 16 bar g. Use M10S2 or M10S4 for higher pressures.

# 3. Installation

**Note:** Before actioning any installation observe the 'Safety information' in Section 1.

As with all instrumentation, the Spirax Sarco pressure gauge is a delicate measuring device and care has to be taken in its installation and use if it is to remain reliable.

It is recommended that all gauges are fitted with a gauge cock to assist when calibration or maintenance is necessary. When used on steam or other hot gases, gauges **must** be protected from heat by the use of a 'U' syphon or ring syphon tube and gauge cock. The syphon pipe should be primed with water prior to fitting the gauge. Care should be taken if the installation is exposed to frost as gauges can burst.

Gauges should be adequately protected from either mechanical vibration or rapid system pulsation.

Tighten the gauge with care using a 22 mm A/F spanner not by twisting the gauge case. Gauges should be selected so as not to exceed 75% of maximum scale reading during normal use.

## Typical uses of a 'U' syphon and gauge

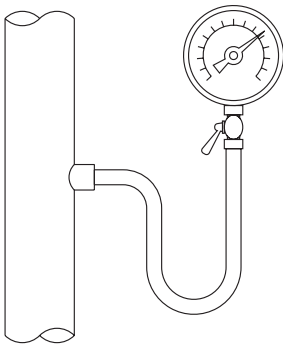

**Fig. 2 Vertical pipe**

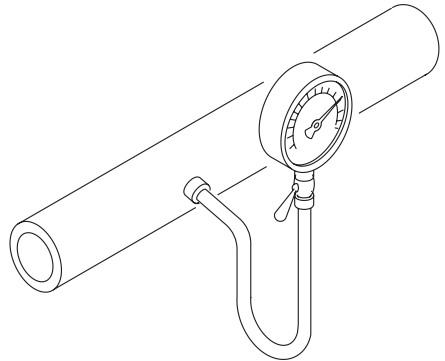

**Fig. 3 Horizontal pipe**  
(where no headroom exists)

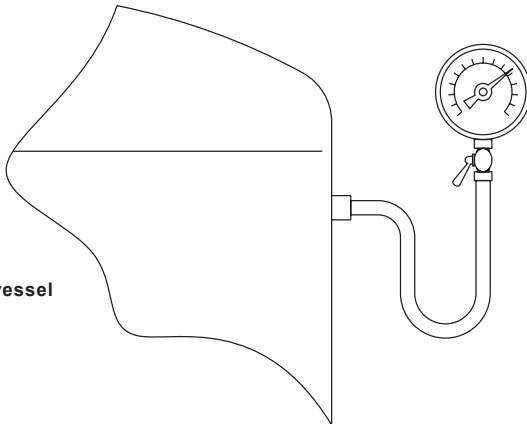

**Fig. 4 Side of vessel**



## Typical uses of a ring syphon and gauge

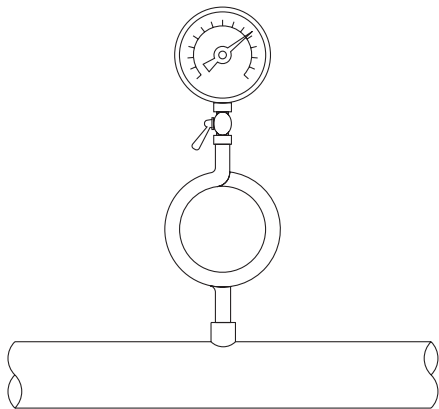

**Fig. 5 Horizontal pipe**  
(where headroom allows)

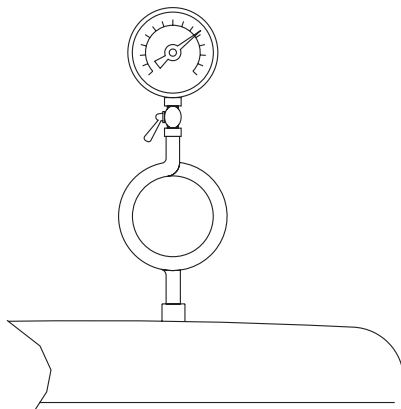

**Fig. 6 Top of vessel**

## 4. Commissioning

After installation or maintenance ensure that the system is fully functioning. Carry out tests on any alarms or protective devices.

## 5. Operation

The Spirax Sarco pressure gauge is designed to indicate the pressure within the system.

As pressure is admitted, the bourdon tube tends to straighten out, converting pressure to displacement. The tube is linked to a pinion which is attached to a pointer, this then displays the pressure reading on a circular scale.

## 6. Maintenance

There are no spare parts for the Spirax Sarco pressure gauge: the only maintenance work necessary is regular cleaning of the perspex window and recalibration. Solvents should not be used to clean the perspex window as it may impair clarity.

**Note: Gauge cocks should always be opened and closed slowly to avoid pressure shocks to the gauges.**

During recalibration the perspex window can be removed, using a narrow flat-faced screwdriver, placed in the slots on the edge of the window. The pointer can be gently pulled off its spindle and replaced at the correct reading by gently pushing back on to the spindle. After calibration, push fit the window back into position. Refit the gauge to the system.

## 7. Spare parts

There are no spare parts available for the Spirax Sarco pressure gauge.

### How to order a new product

**Example:** 1 off Spirax Sarco  $\frac{3}{8}$ " pressure gauge with a pressure range of 0 - 10 bar and having screwed BSP connections.



